

**Lambda 45 NI**

**Window construction**

## Lambda - Window series

### Contents - Lambda 45 NI

### Page

Contents	2
Series Information	3 - 4
Profile overview   Static profile value	11 - 14
Profiles   Connections	15 - 36
Glazing	41 - 44
Sections / Details	51 - 66
System-dependent accessories	81 - 88
Fittings	101 - 134
Processing	151 - 186
Fitting Installation	201 - 224

002000200

## Modular system\*

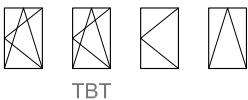
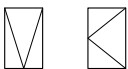
<p><b>Modular system</b></p>	<ul style="list-style-type: none"> <li>• Intelligent modular system for different requirements, functionality and aesthetics</li> <li>• Cost efficiencies on storage due to cross-serial use of glazing beads, fittings, corner- and t-brackets, supplementary profiles and gaskets</li> <li>• Variety of design possibilities, narrow elevation widths, high-quality fitting and accessory parts</li> <li>• Optionally RAL tested, concealed or exposed fittings</li> <li>• Clip-in glazing beads</li> </ul>
<p><b>Surfaces</b></p>	<ul style="list-style-type: none"> <li>• Anodisation in accordance with DIN 17611</li> <li>• Plastic coating (wet paint, powder coating lacquer) in accordance with DIN 50939</li> <li>• Can be coated at a later time</li> </ul>
<p><b>Connecting technology</b></p>	<ul style="list-style-type: none"> <li>• Corner bracket: crimpable, nailable</li> <li>• T-brackets for fixed frame joints and transom joints</li> </ul>
<p><b>Opening types</b></p>	<p>Opening in  TBT</p> <p>Opening out </p>

## Series information\*

<p><b>Design features</b></p>	<ul style="list-style-type: none"> <li>• One-chamber profiles</li> <li>• Max. sash weight 160 kg (refer to fittings)</li> </ul>
<p><b>Elevation width</b></p>	<ul style="list-style-type: none"> <li>• Narrow elevation width of fixed frame/sash combination from 88.7 mm</li> </ul>
<p><b>Profile depth</b></p>	<ul style="list-style-type: none"> <li>• Fixed frame: 45 mm</li> <li>• Sash frame: 55 mm</li> </ul>
<p><b>Glazing</b></p>	<ul style="list-style-type: none"> <li>• Glass thickness between 6 mm and 24 mm</li> </ul>
<p><b>Gaskets</b></p>	<ul style="list-style-type: none"> <li>• Glazing/rebate gaskets: narrow view on inside and outside</li> <li>• All gaskets coated with sliding polymer</li> </ul>



\* All standards referred to herein, were valid at time of printing.

Valid test reports as well as technical information can be found in the download area of the site [www.hueck.com](http://www.hueck.com)





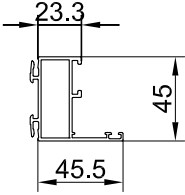
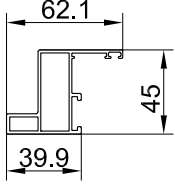
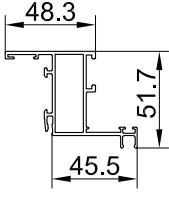
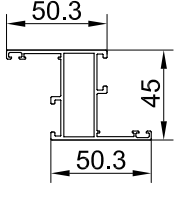
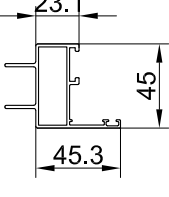
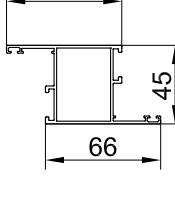
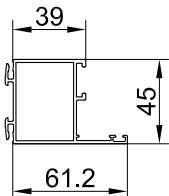
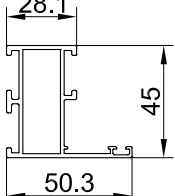
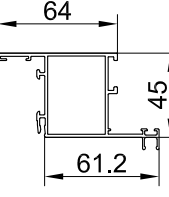
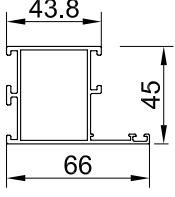
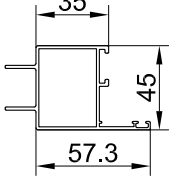
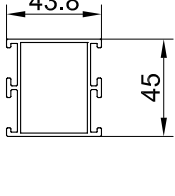
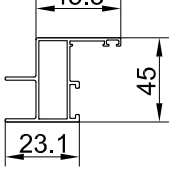
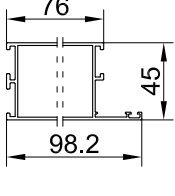

## Profile overview and static profile values for Series Lambda 45 NI



	Profile number	Horizontal axis		Vertical axis		External perimeter complete	Page -		Profile number	Horizontal axis		Vertical axis		External perimeter complete	Page -
		$J_x$ (cm <sup>4</sup> )	$W_x$ (cm <sup>3</sup> )	$J_y$ (cm <sup>4</sup> )	$W_y$ (cm <sup>3</sup> )					$J_x$ (cm <sup>4</sup> )	$W_x$ (cm <sup>3</sup> )	$J_y$ (cm <sup>4</sup> )	$W_y$ (cm <sup>3</sup> )		
	P 815100	8	3	5	1	283	15		P 815108	10	4	7	2	259	19
	P 815101	12	4	10	3	362	18		P 815309	11	5	8	2	328	20
	P 815103	8	3	6	2	289	19		P 815310	13	6	18	4	359	20
	P 815104	11	4	12	3	314	15		P 815111	9	3	5	2	276	16
	P 815105	14	5	20	5	394	18		P 815112	11	4	13	3	307	16
	P 815106	10	4	14	3	320	19		P 815113	9	4	8	4	256	17
	P 815107	9	4	6	2	290	19		P 815114	16	7	43	8	372	17

011000100

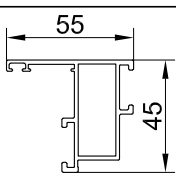
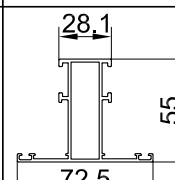
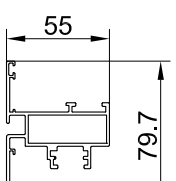
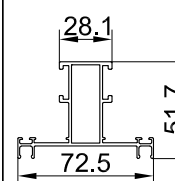
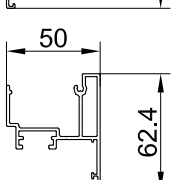
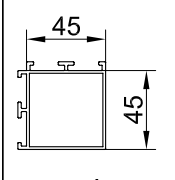
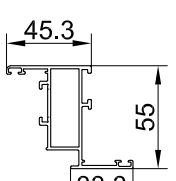
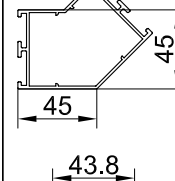
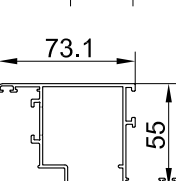
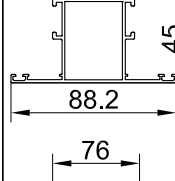
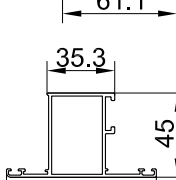
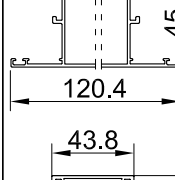
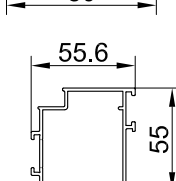
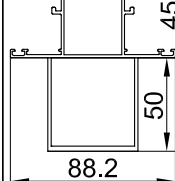
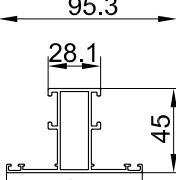
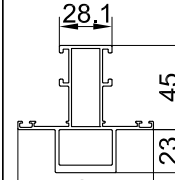
## Profile overview and static profile values for Series Lambda 45 NI

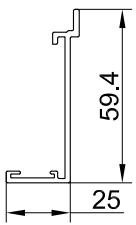
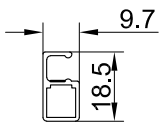
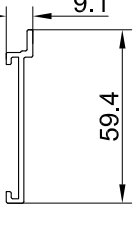
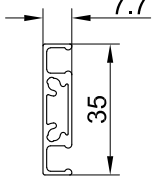
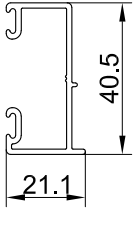
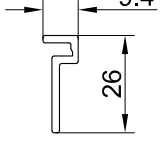
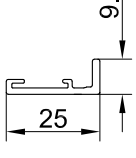
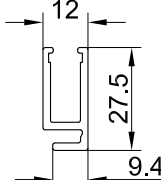
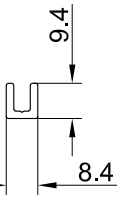
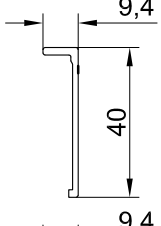
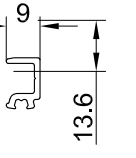
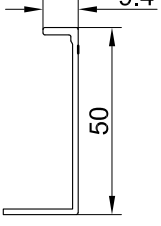
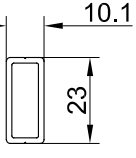
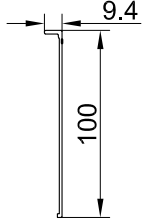

	Profile number	Horizontal axis		Vertical axis		External perimeter complete	Page		Profile number	Horizontal axis		Vertical axis		External perimeter complete	Page
		$J_x$ (cm <sup>4</sup> )	$W_x$ (cm <sup>3</sup> )	$J_y$ (cm <sup>4</sup> )	$W_y$ (cm <sup>3</sup> )					$J_x$ (cm <sup>4</sup> )	$W_x$ (cm <sup>3</sup> )	$J_y$ (cm <sup>4</sup> )	$W_y$ (cm <sup>3</sup> )		
	P 815118	7	2	5	1	254	17		P 815301	16	5	9	2	353	28
	P 815220	12	3	17	5	443	25		P 815302	21	8	13	4	380	21
	P 815225	8	2	11	4	351	25		P 815303	13	5	13	5	278	24
	P 815240	14	5	7	2	351	26		P 815304	16	5	25	8	311	24
	P 815250	22	8	27	6	400	26		P 815306	12	5	18	4	359	22
	P 815260	11	4	13	3	317	27		P 815307	17	7	52	9	423	22
	P 815270	21	6	27	6	400	27		P 815308	68	14	29	7	459	23
	P 815300	10	4	8	2	328	21		P 815311	11	4	26	6	373	23

## Profile overview and static profile values for Series Lambda 45 NI

	Profile number	Horizontal axis		Vertical axis		External perimeter complete	Page -		Profile number	Horizontal axis		Vertical axis		External perimeter complete	Page -
		$J_x$ (cm <sup>4</sup> )	$W_x$ (cm <sup>3</sup> )	$J_y$ (cm <sup>4</sup> )	$W_y$ (cm <sup>3</sup> )					$J_x$ (cm <sup>4</sup> )	$W_x$ (cm <sup>3</sup> )	$J_y$ (cm <sup>4</sup> )	$W_y$ (cm <sup>3</sup> )		
	P 815601	7	2	1	0	197	30		P 815622	0	0	0	0	68	31
	P 815602	5	2	0	0	153	30		P 815623	1	1	0	0	111	31
	P 815603	1	1	3	2	210	29		P 815624	0	0	0	0	80	31
	P 815604	0	0	0	0	85	30		P 815625	1	1	0	0	136	31
	P 815605	0	0	0	0	49	30		P 815626	1	1	0	0	99	32
	P 815611	-	-	-	-	62	29		P 815627	4	1	0	0	154	32
	P 815621	-	-	-	-	65	29		P 815628	17	3	0	0	219	32

013000300

## Profile overview and static profile values for Series Lambda 45 NI

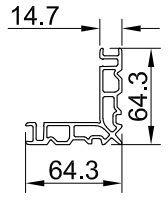
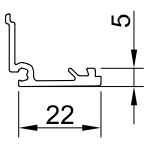
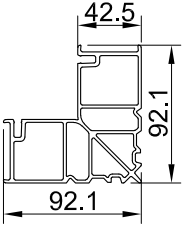
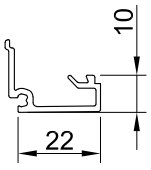
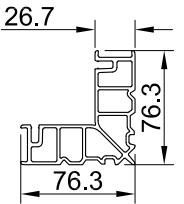
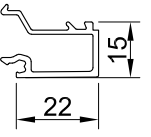
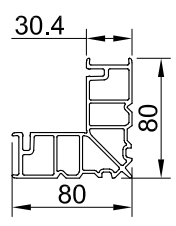
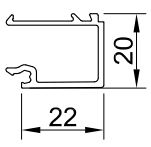
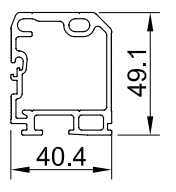
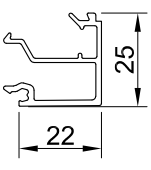
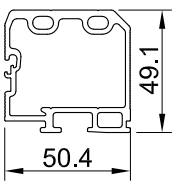
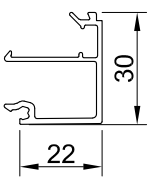
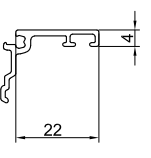
	Profile number	Horizontal axis		Vertical axis		External perimeter complete	Page		Profile number	Horizontal axis		Vertical axis		External perimeter complete	Page
		$J_x$ (cm <sup>4</sup> )	$W_x$ (cm <sup>3</sup> )	$J_y$ (cm <sup>4</sup> )	$W_y$ (cm <sup>3</sup> )					$J_x$ (cm <sup>4</sup> )	$W_x$ (cm <sup>3</sup> )	$J_y$ (cm <sup>4</sup> )	$W_y$ (cm <sup>3</sup> )		
	P 599343	-	-	-	-	350	33		P 815400	-	-	-	-	226	41
	P 599346	-	-	-	-	459	33		P 815401	-	-	-	-	245	41
	P 599348	-	-	-	-	396	33		P 494400	-	-	-	-	287	41
	P 599364	-	-	-	-	411	33		P 494401	-	-	-	-	295	41
	P 599362	-	-	-	-	228	34		P 494402	-	-	-	-	343	41
	P 599363	-	-	-	-	248	34		P 494403	-	-	-	-	353	41
									P 816608	-	-	-	-	208	41



## P 815100

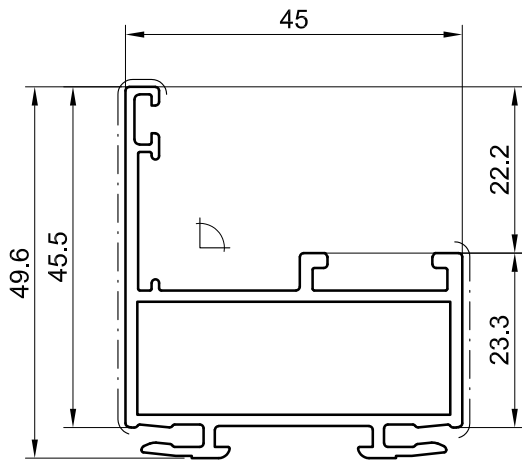



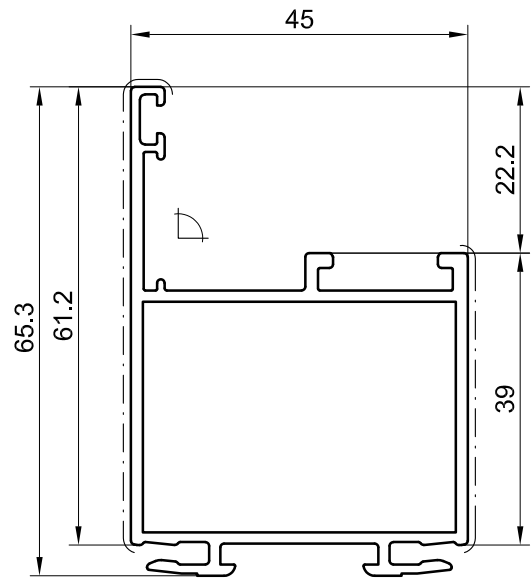







## P 815104

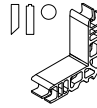

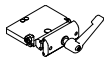
Scale 1:1

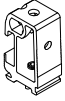
015000600

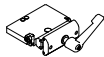
<ul style="list-style-type: none"> <li> crimpable</li> <li> nailable</li> <li> retro gluing after assembly</li> </ul>	chamber				
					
<b>P 815100</b>	Z 917772	Z 918394	4x Z 911049	Z 911187	-
<b>P 815104</b>	Z 917772	Z 918601	4x Z 911049	Z 911187	-
					
<b>P 815100</b>	-	Z 918502	2x Z 911049	Z 911187	-
<b>P 815104</b>	-	Z 918702	4x Z 911049	Z 911187	-

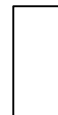



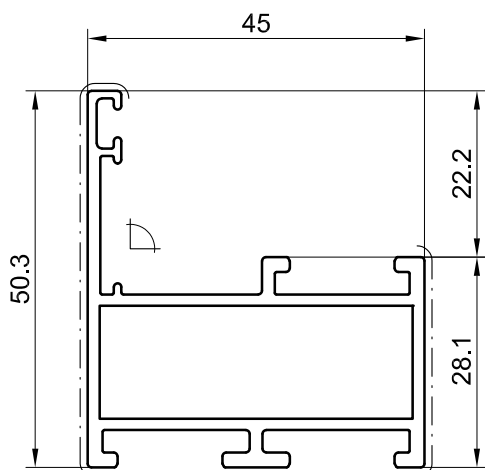



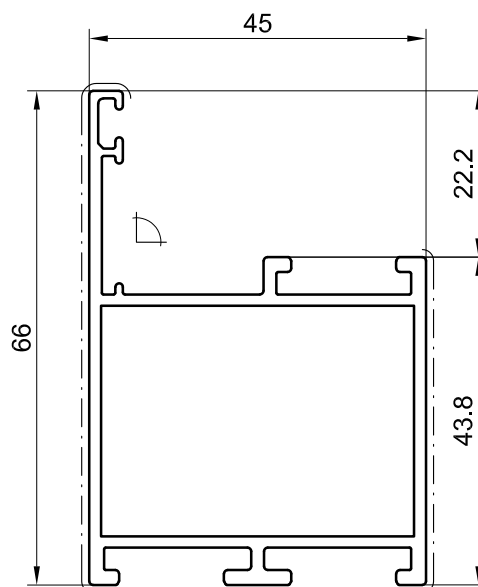





## P 815111



## P 815112



Scale 1:1

<ul style="list-style-type: none"> <li> crimpable</li> <li> nailable</li> <li> retro gluing after assembly</li> </ul>	chamber				
					
<b>P 815111</b>	Z 917772	Z 918394	4x Z 911049	Z 911187	-
<b>P 815112</b>	Z 917772	Z 918601	4x Z 911049	Z 911187	-
					
<b>P 815111</b>	-	Z 918502	2x Z 911049	Z 911187	-
<b>P 815112</b>	-	Z 918702	4x Z 911049	Z 911187	-

016000600

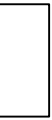

P 815113

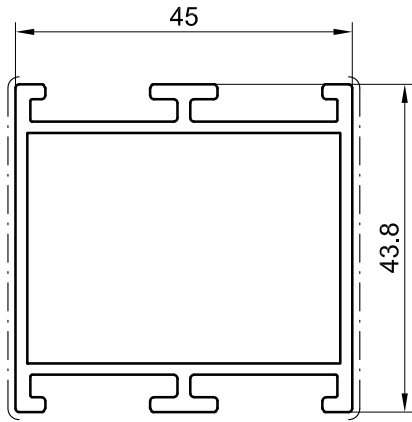



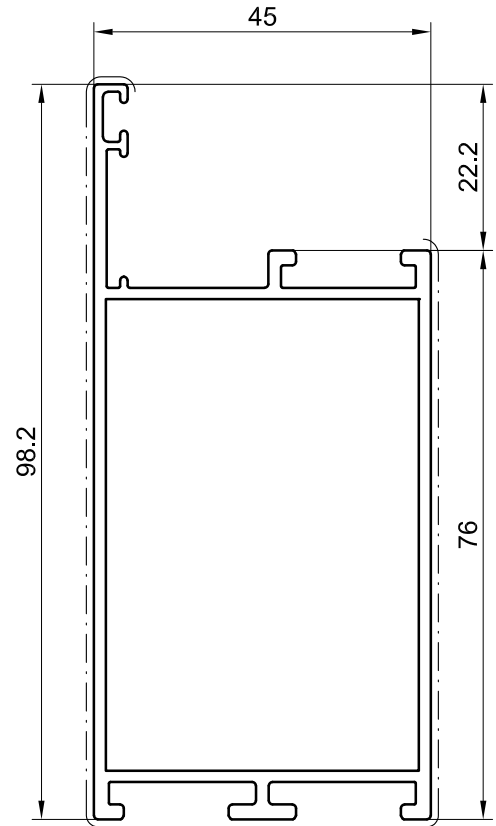



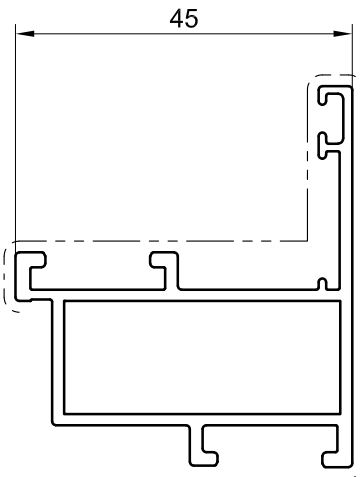





P 815114

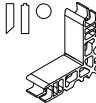

P 815118



Scale 1:1

 crimpable  nailable  retro gluing after assembly	chamber				
					
<b>P 815113</b>	-	Z 918601	4x Z 911049	Z 911187	-
<b>P 815114</b>	-	-	-	-	-
<b>P 815118</b>	-	Z 923245	4x Z 911049	Z 911187	-
					
<b>P 815113</b>	-	Z 918702	4x Z 911049	Z 911187	-
<b>P 815114</b>	-	Z 918703	4x Z 911049	Z 911187	-
<b>P 815118</b>	-	-	-	-	-

017000700





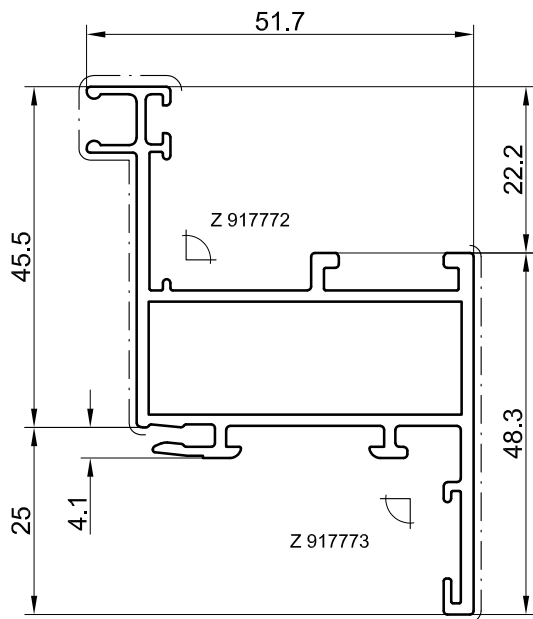



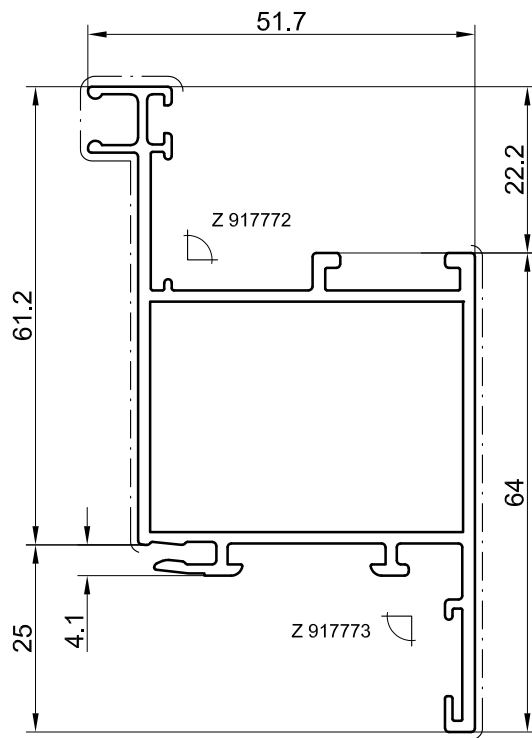



## P 815101

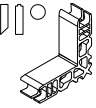

## P 815105

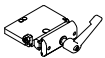

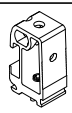
Scale 1:1

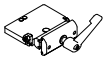
 crimpable  nailable  retro gluing after assembly	chamber				
					
<b>P 815101</b>	Z 917772 / Z 917773	Z 918394	4x Z 911049	Z 911187	-
<b>P 815105</b>	Z 917772 / Z 917773	Z 918601	4x Z 911049	Z 911187	-
					
<b>P 815101</b>	-	Z 918502	2x Z 911049	Z 911187	-
<b>P 815105</b>	-	Z 918702	4x Z 911049	Z 911187	-

018000800



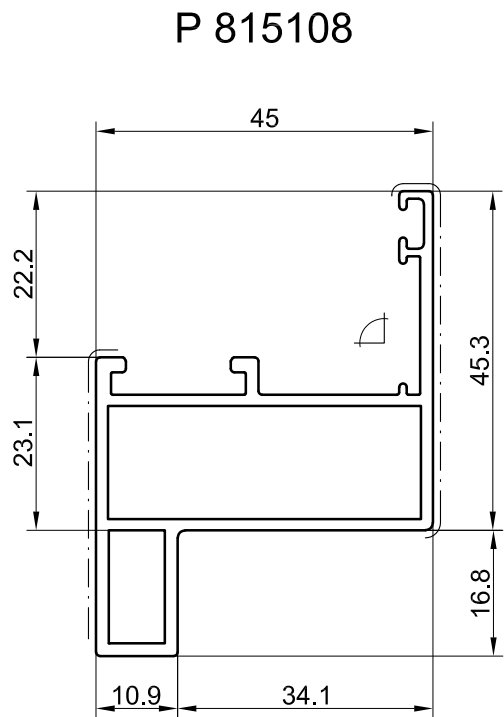
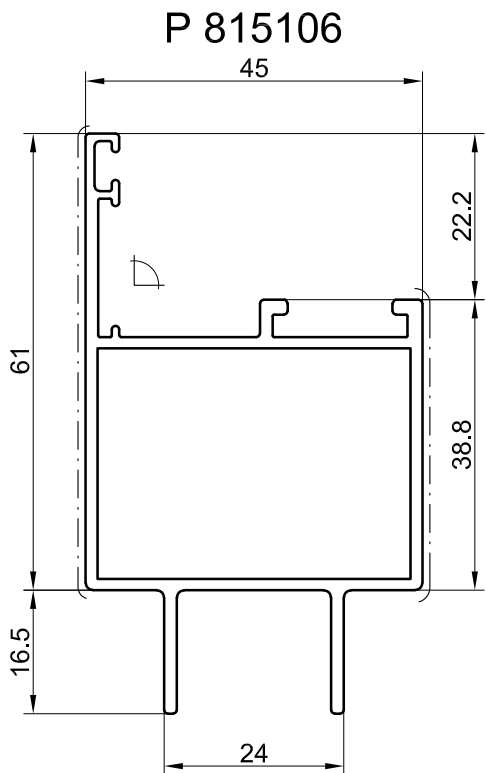
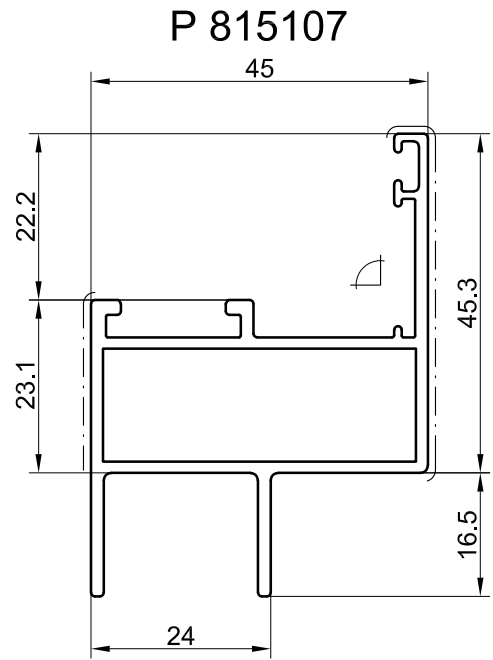
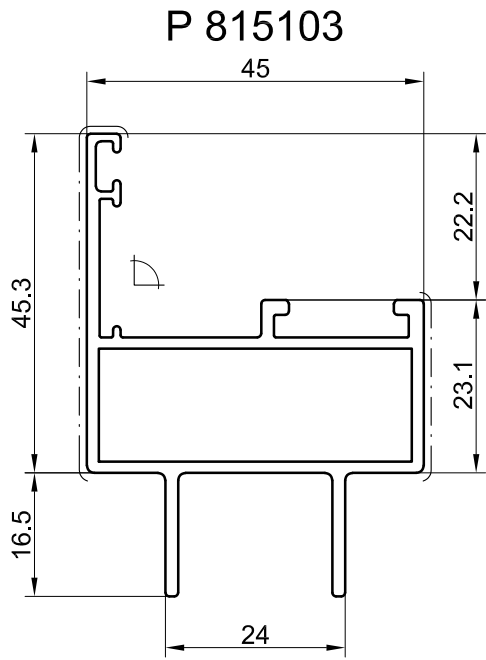

Scale 1:1

0190009000

	chamber				
<b>P 815103</b>	Z 917772	Z 918394	4x Z 911049	Z 911187	-
<b>P 815106</b>	Z 917772	Z 918601	4x Z 911049	Z 911187	-
<b>P 815107</b>	Z 917772	Z 918394	4x Z 911049	Z 911187	-
<b>P 815108</b>	Z 917772	Z 918394	4x Z 911049	Z 911187	-





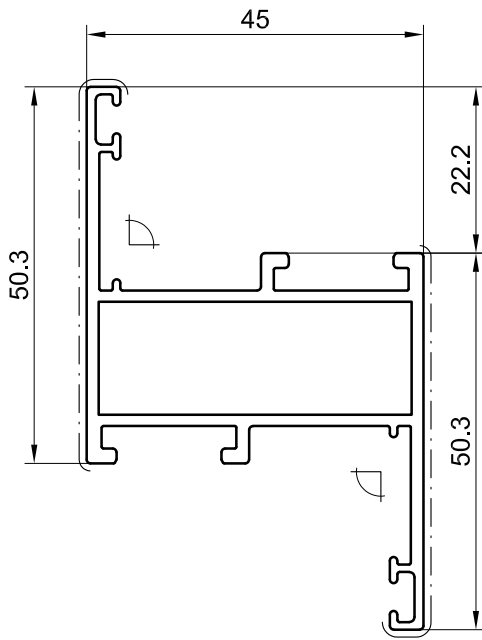



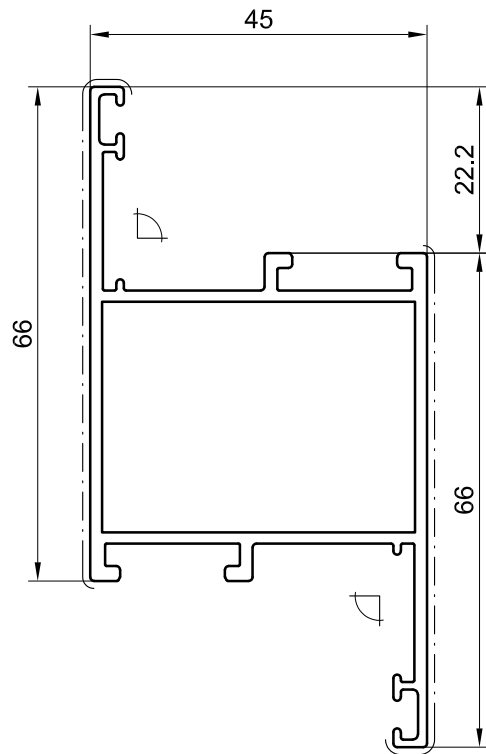





P 815309

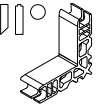

P 815310

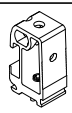

Scale 1:1

 crimpable  nailable  retro gluing after assembly	chamber				
					
<b>P 815309</b>	2x Z 917772	Z 918394	4x Z 911049	Z 911187	-
<b>P 815310</b>	2x Z 917772	Z 918601	4x Z 911049	Z 911187	-
					
<b>P 815309</b>	-	Z 918502	2x Z 911049	Z 911187	-
<b>P 815310</b>	-	Z 918702	4x Z 911049	Z 911187	-

020001000

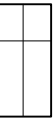

## P 815300

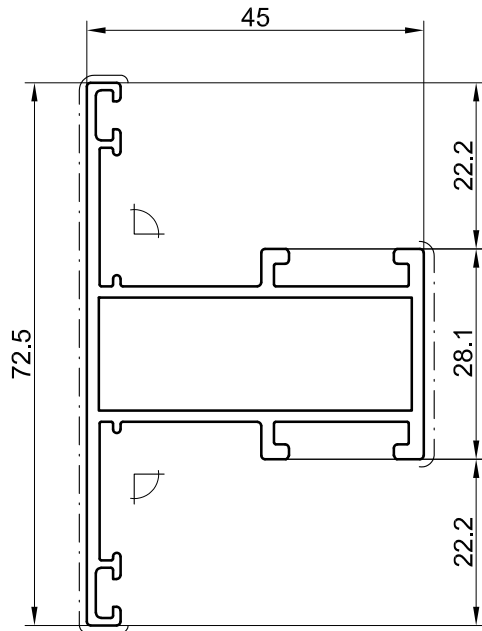

## P 815302

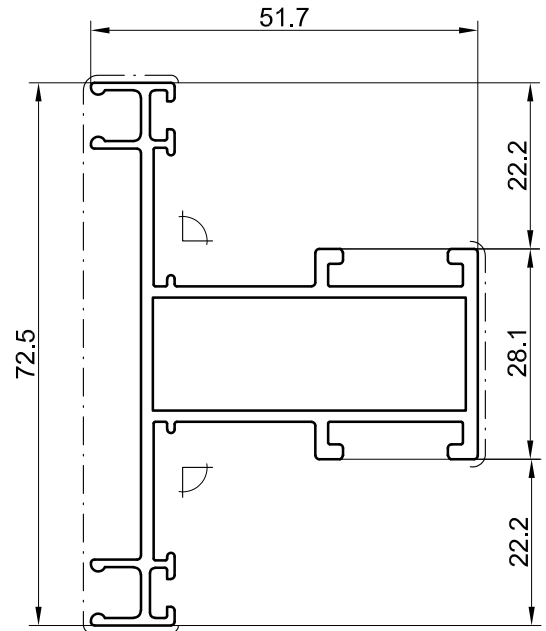

Scale 1:1

021001100

	chamber				
<b>P 815300</b>	2x Z 917772	Z 918394	4x Z 911049	Z 911187	-
<b>P 815302</b>	2x Z 917772	Z 918394	4x Z 911049	Z 911187	-
<b>P 815300</b>	-	Z 918502	2x Z 911049	Z 911187	-
<b>P 815302</b>	-	Z 918502	2x Z 911049	Z 911187	-





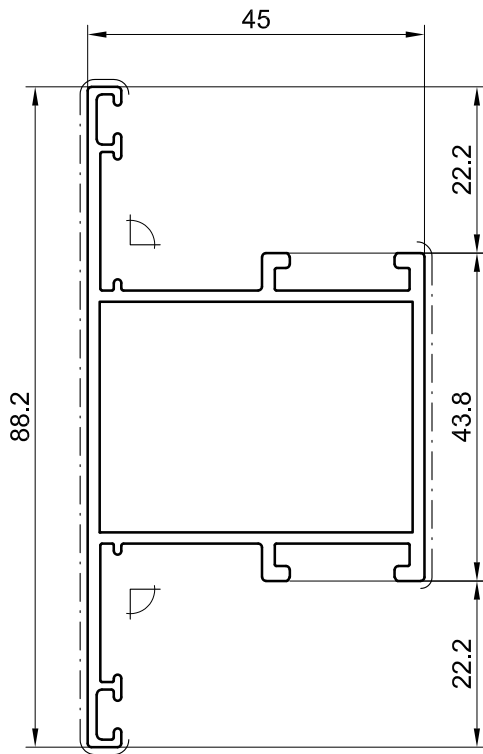



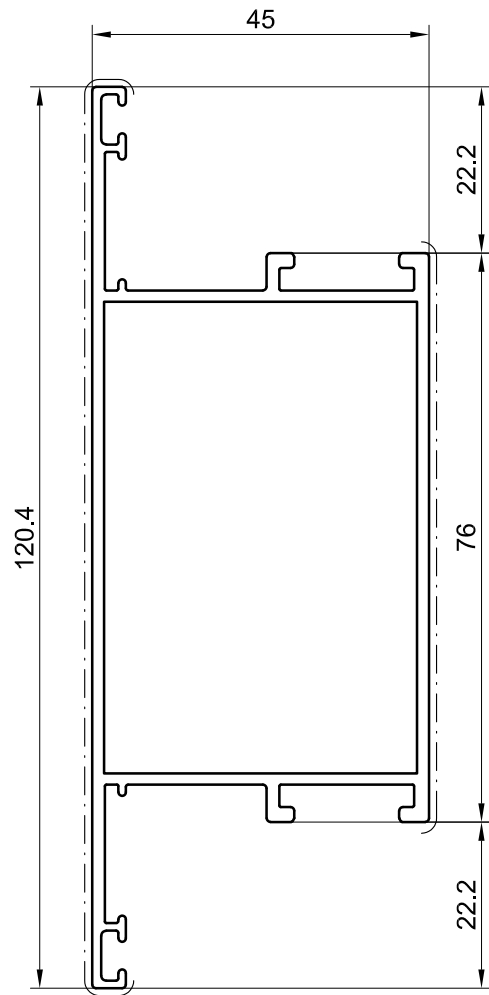



P 815306

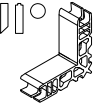

P 815307

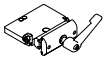

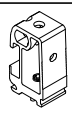
Scale 1:1

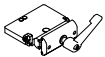
 crimpable  nailable  retro gluing after assembly	chamber				
					
<b>P 815306</b>	2x Z 917772	Z 918601	4x Z 911049	Z 911187	-
<b>P 815307</b>	-	-	-	-	-
					
<b>P 815306</b>	-	Z 918702	4x Z 911049	Z 911187	-
<b>P 815307</b>	-	Z 918703	4x Z 911049	Z 911187	-

022001200

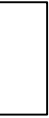

## P 815308

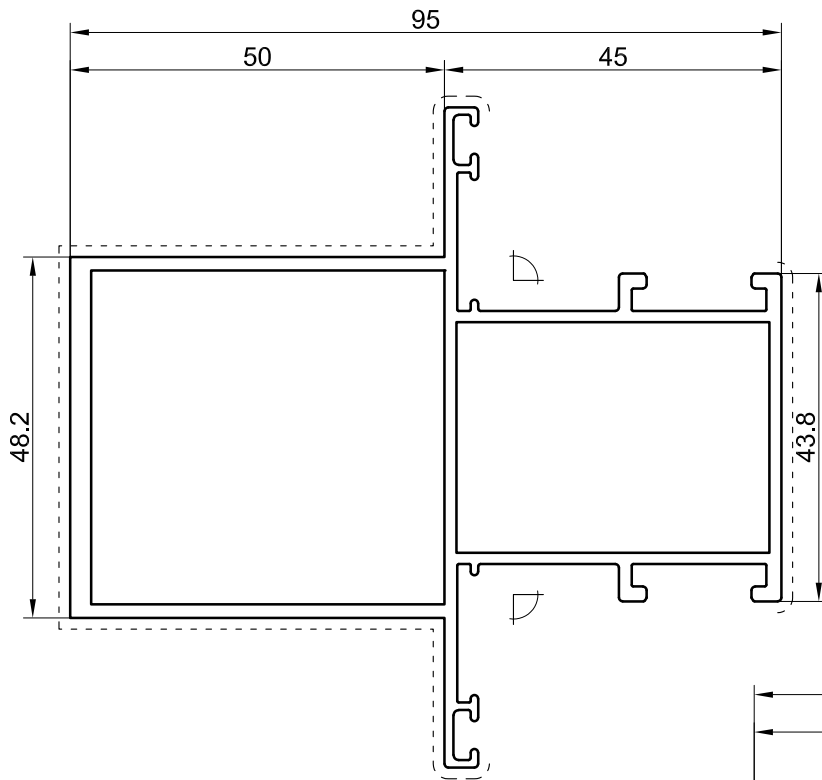

## P 815311

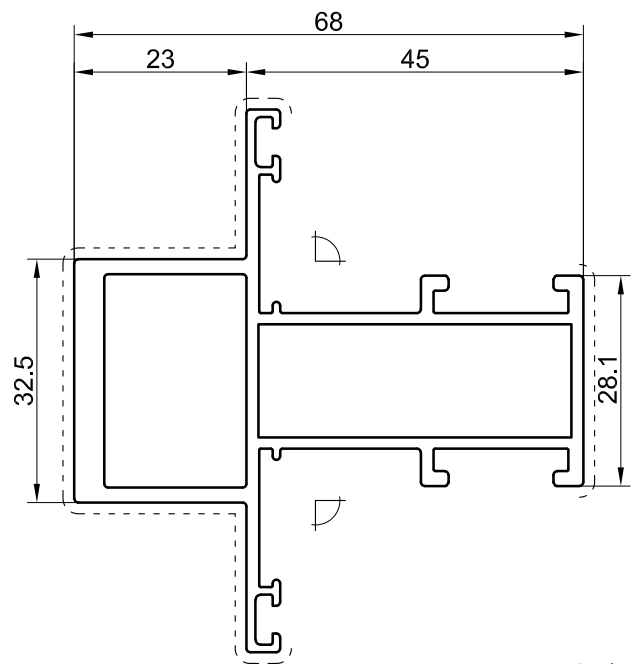

Scale 1:1

023001300

	chamber				
<b>P 815308</b>	2x Z 917772	Z 918601	4x Z 911049	Z 911187	-
<b>P 815311</b>	2x Z 917772	Z 918394	4x Z 911049	Z 911187	-
<b>P 815308</b>	-	Z 918702	4x Z 911049	Z 911187	-
<b>P 815311</b>	-	Z 918502	2x Z 911049	Z 911187	-





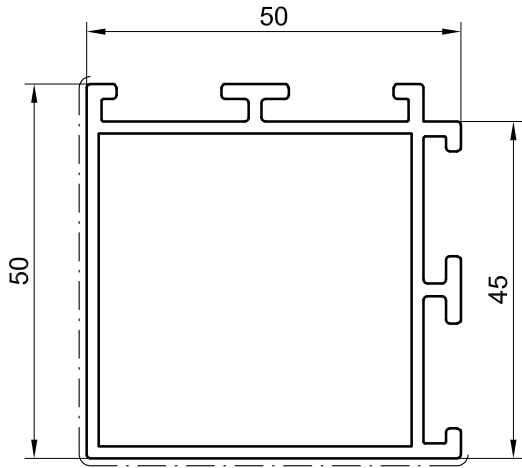



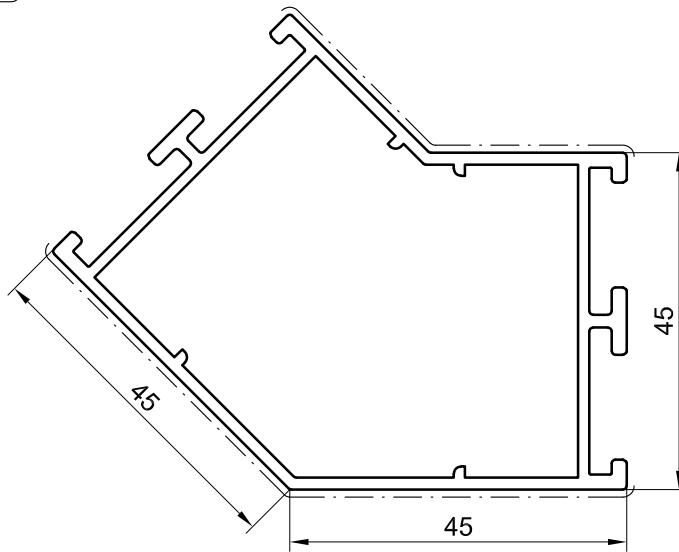



P 815303

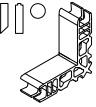

P 815304

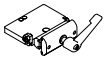

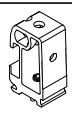
Scale 1:1

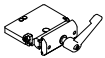
<ul style="list-style-type: none"> <li> crimpable</li> <li> nailable</li> <li> retro gluing after assembly</li> </ul>	chamber				
					
<b>P 815303</b>	-	-	-	-	-
<b>P 815304</b>	-	-	-	-	-
					
<b>P 815303</b>	-	-	-	-	-
<b>P 815304</b>	-	-	-	-	-

024001400

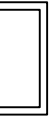

P 815220

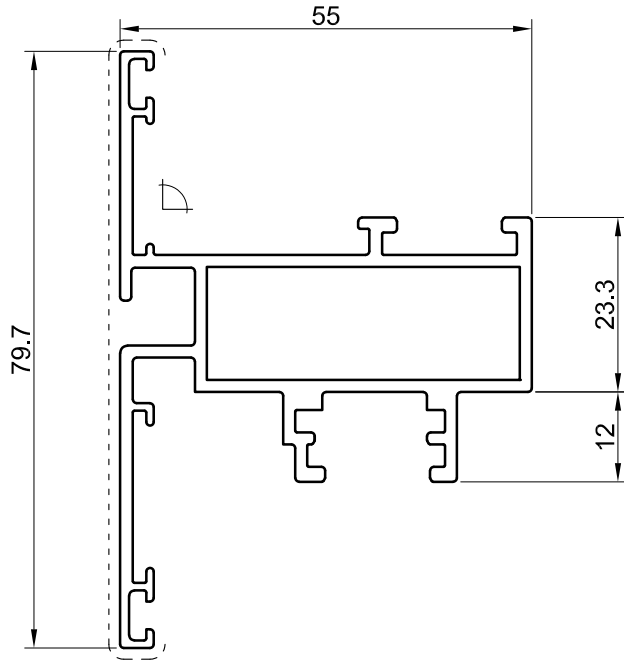

P 815225

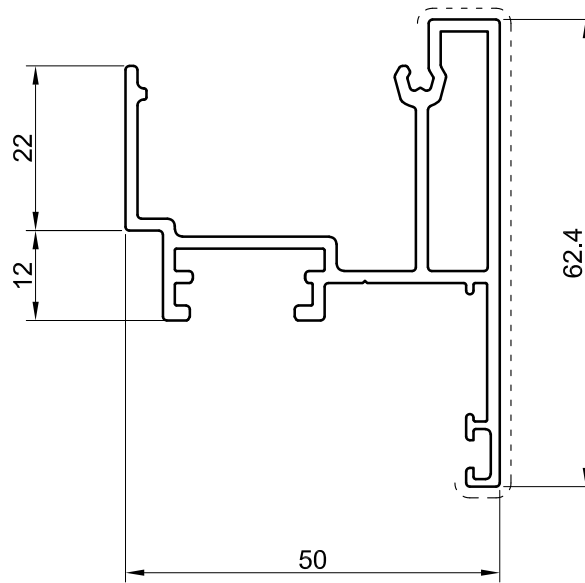

Scale 1:1

025001500

	chamber				
P 815220	Z 917772	Z 918394	4x Z 911049	Z 911187	-
P 815225	-	-	-	-	-
P 815220	-	-	-	-	-
P 815225	-	-	-	-	-



## P 815240

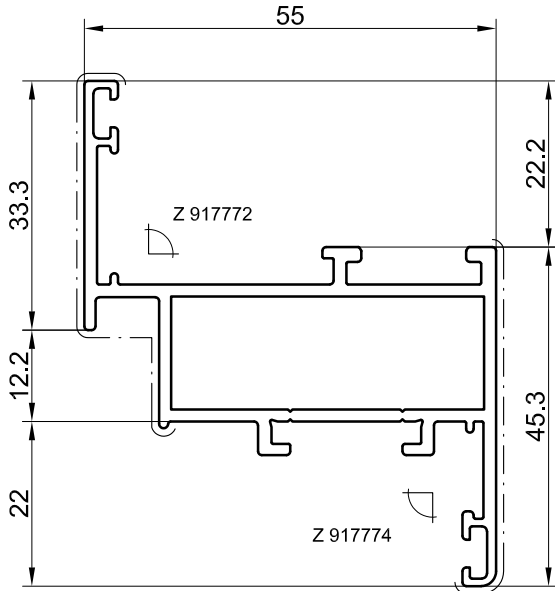





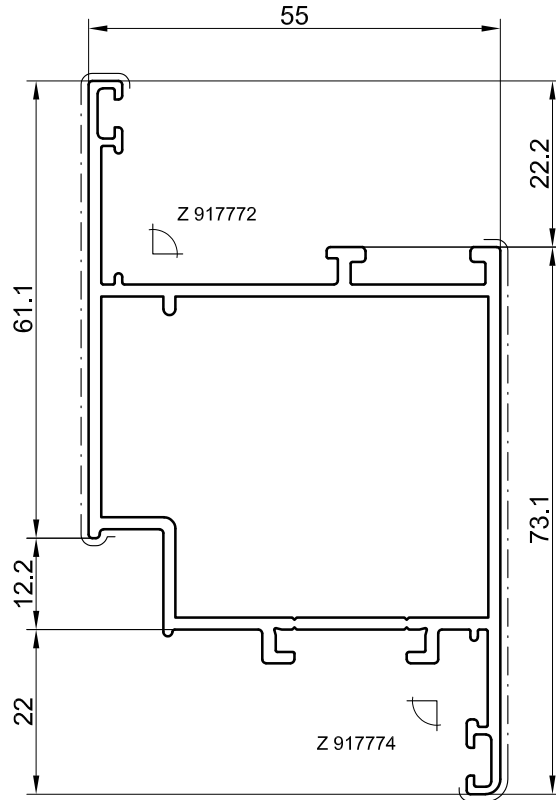



Operating rod  
K 910137

## P 815250

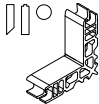

Operating rod  
K 910137

Scale 1:1

<ul style="list-style-type: none"> <li> crimpable</li> <li> nailable</li> <li> retro gluing after assembly</li> </ul>	chamber				
					
<b>P 815240</b>	Z 917772 / Z 917774	Z 918394	4x Z 911049	Z 911187	-
<b>P 815250</b>	Z 917772 / Z 917774	Z 918395	4x Z 911049	Z 911187	-

026001600



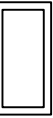

## P 815260

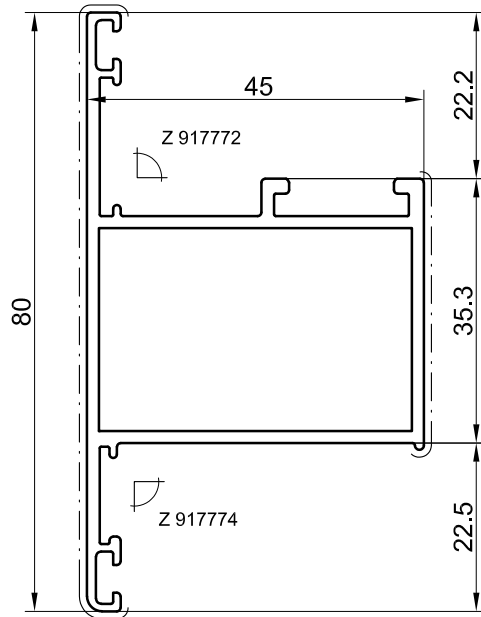

## P 815270

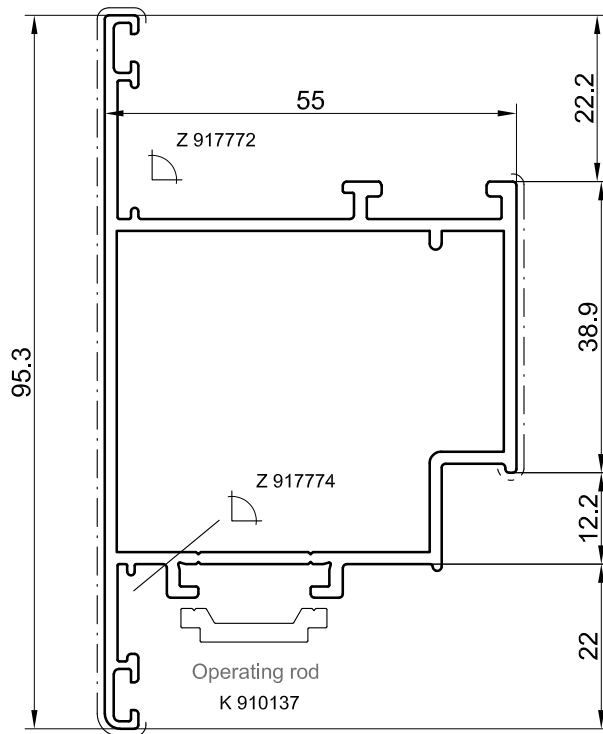

Scale 1:1

027001700



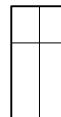



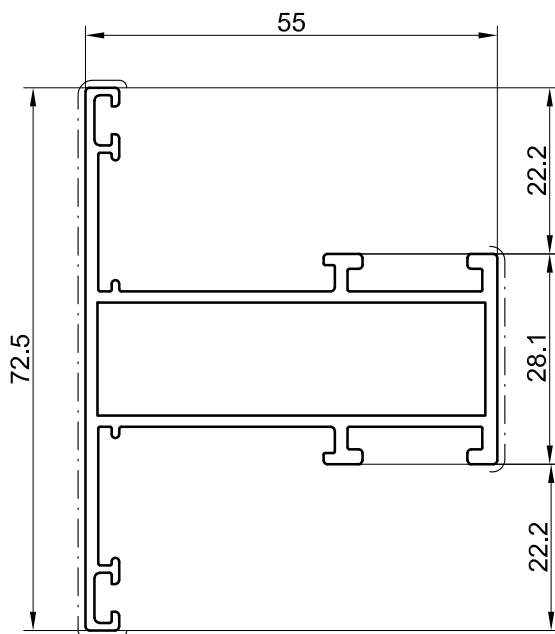

	chamber				
<b>P 815260</b>	Z 917772 / Z 917774	Z 918491	4x Z 911049	Z 911187	-
<b>P 815270</b>	Z 917772 / Z 917774	Z 918395	4x Z 911049	Z 911187	-



## P 815301

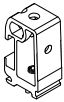

Scale 1:1

<ul style="list-style-type: none"> <li> crimpable</li> <li> nailable</li> <li> retro gluing after assembly</li> </ul>	chamber				
					
<b>P 815301</b>	-	Z 918503	2x Z 911049	Z 911187	-

028001800

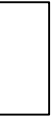

P 815603

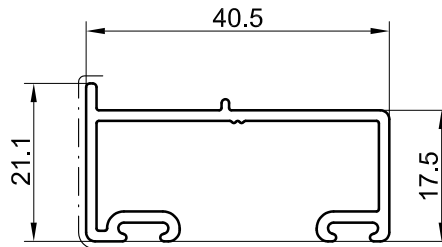

P 815611

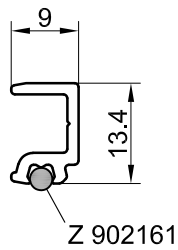

P 815621

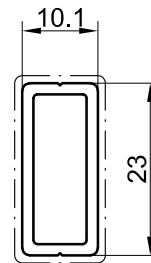

029001900

Scale 1:1

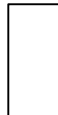

P 815601

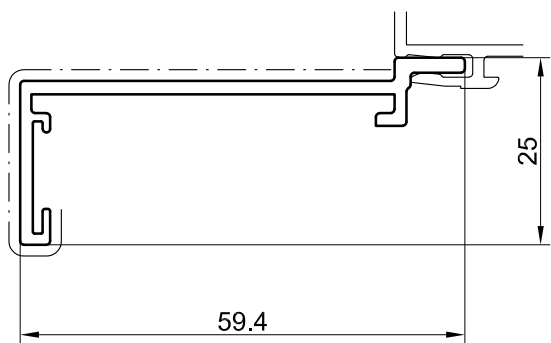

P 815602

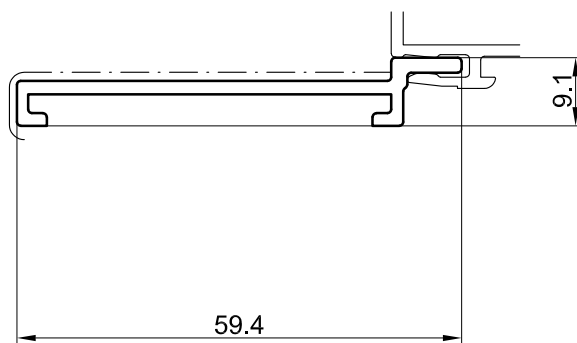

P 815604

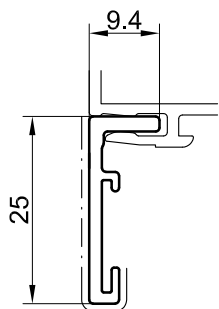

P 815605

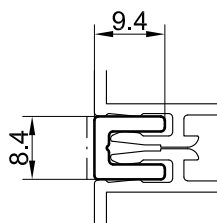

Scale 1:1

P 815622

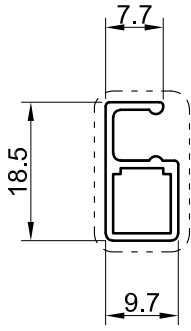

P 815623

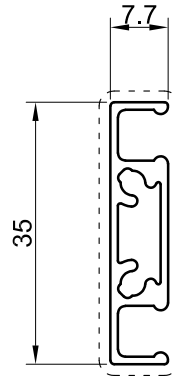

P 815624

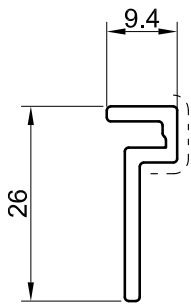

P 815625

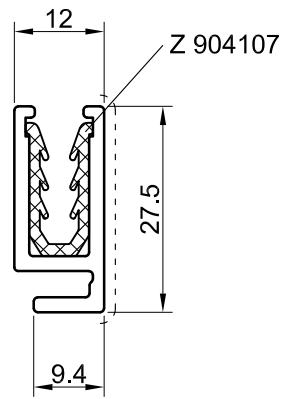

031002100

Scale 1:1

P 815626

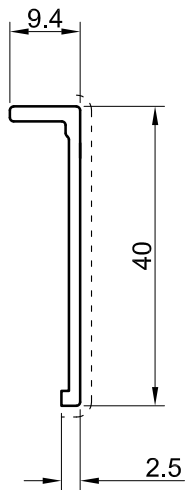

P 815627

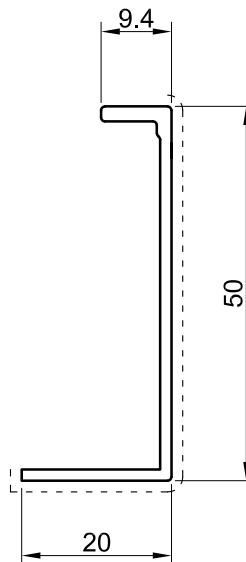

P 815628

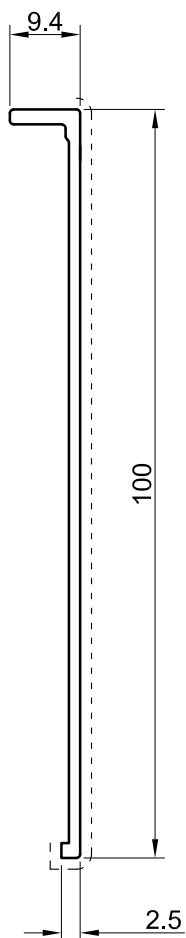

Scale 1:1

032002200

### P 599343

article no.:	profile no.:	length
Z918394	P599343	41,4 mm
Z923245	P599343	36,5 mm

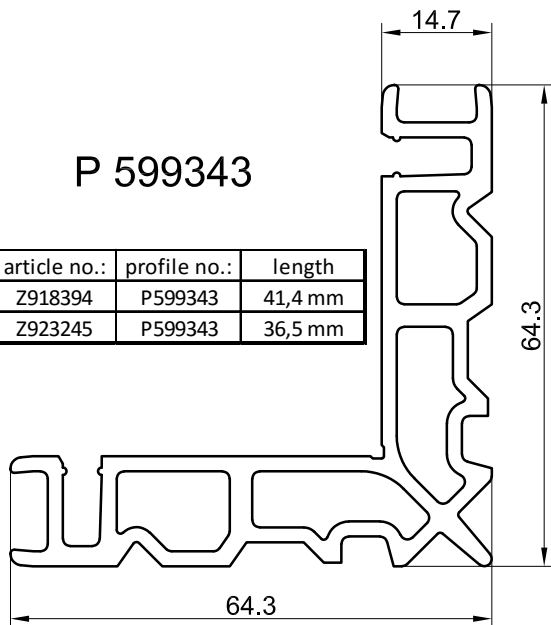

### P 599346

article no.:	profile no.:	length
Z918395	P599346	41,4 mm

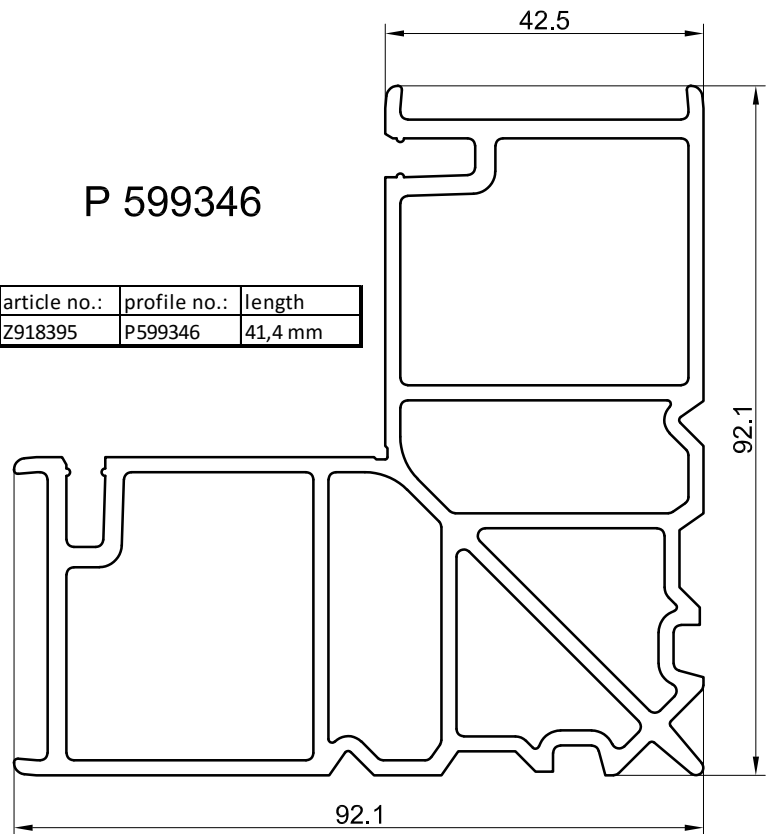

### P 599348

article no.:	profile no.:	length
Z918491	P599348	41,4 mm

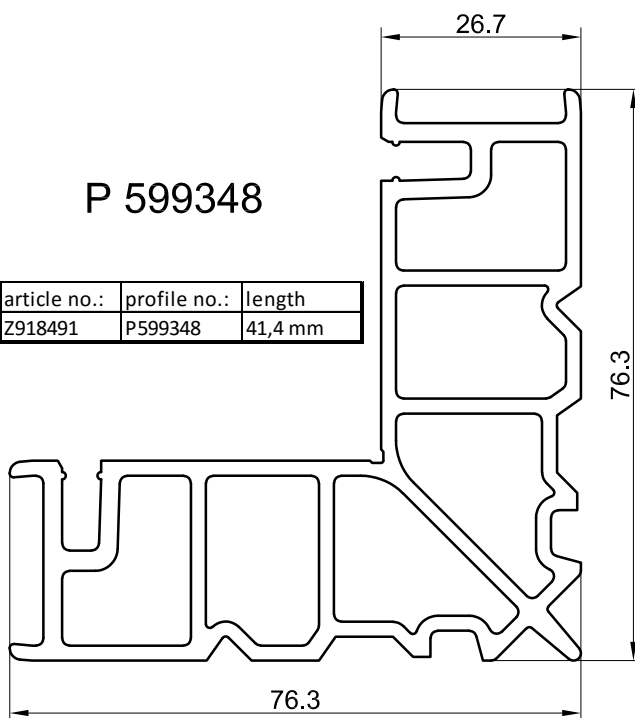

### P 599364

article no.:	profile no.:	length
Z918601	P599364	41,4 mm

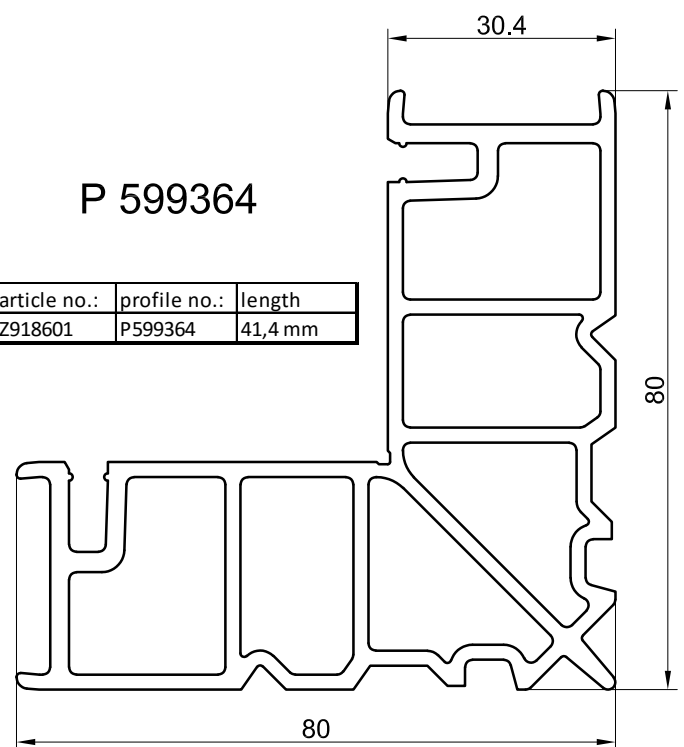

033002300

Scale 1:1

P 599362

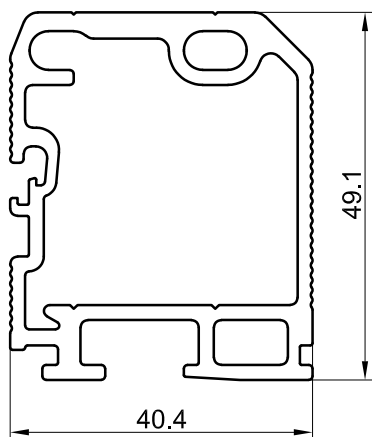

P 599363

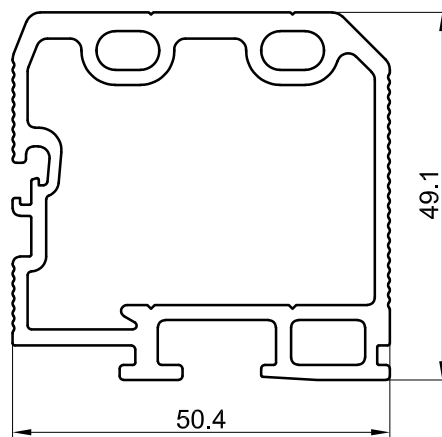

article no.:	profile no.:	length	gasket	screw
Z918502	P599362	14,7 mm	Z914288	2 x 917691
Z918702	P599362	30,4 mm	Z914288	2 x 917691
Z918703	P599362	62,6 mm	Z914288	4 x 917691
Z918503	P599363	14,7 mm	Z914288	2 x 917691

Scale 1:1



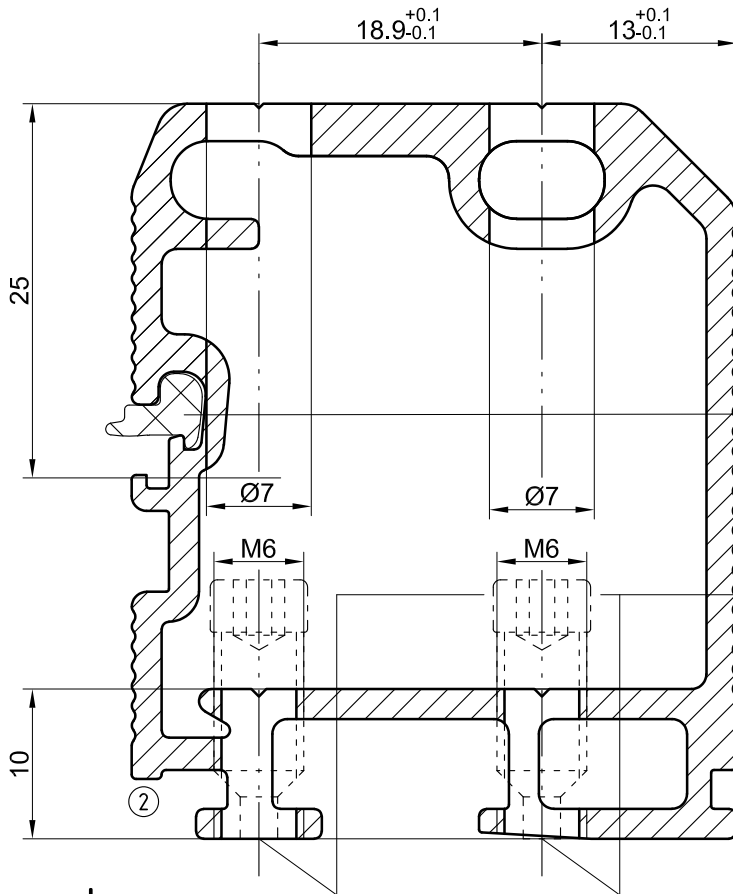

**the scop of delivery include:**

- ★ - silicon gasket strip Z914288  
is to be:
  - cut to fit
  - joined in
  - secure against inadvertment movement
- punch screw M6 art.-no. 2 x Z917691 is to be:
  - flush screwed

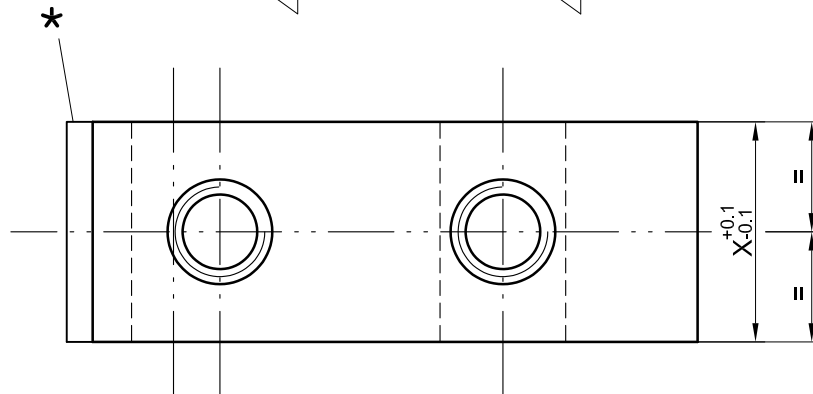

article no.:
Z918502
Z918702

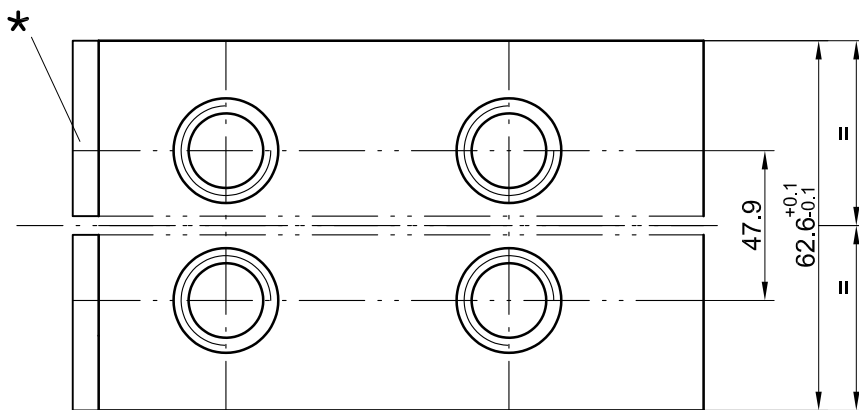

article no.:
Z918703

035002500

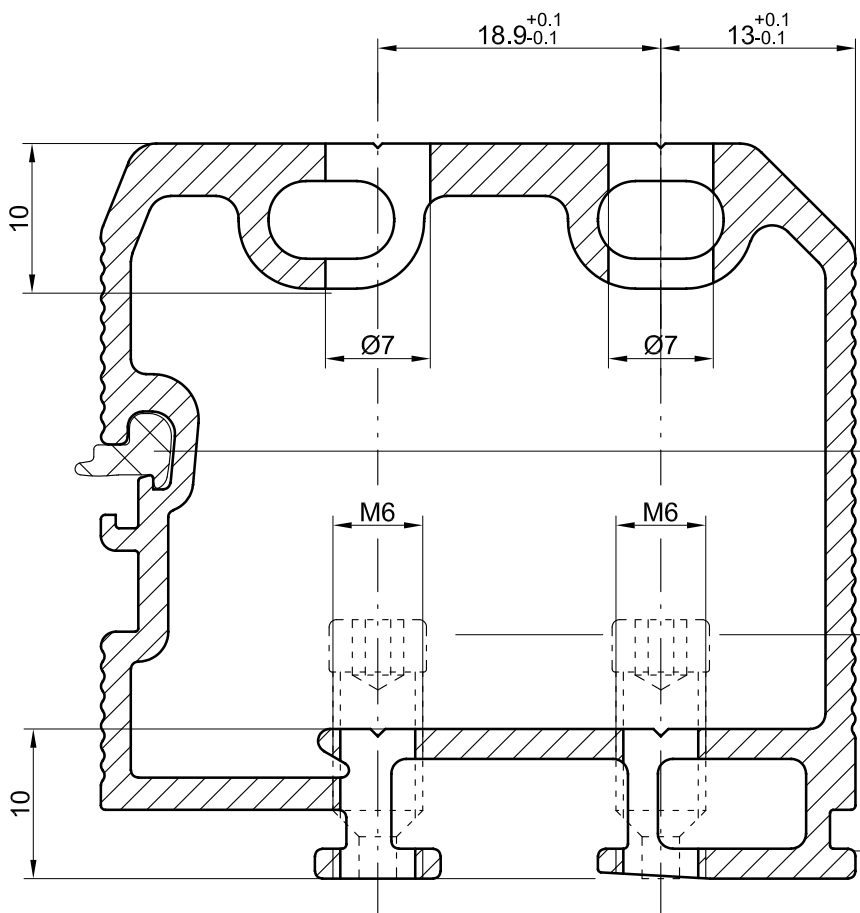

**the scop of delivery include:**

- silicon gasket strip
- Z914288 is to be:
- cut to fit
- joined in
- secure against inadvertent movement

- punch screw M6 art.-no. 2 x Z917691 is to be:
- flush screwed

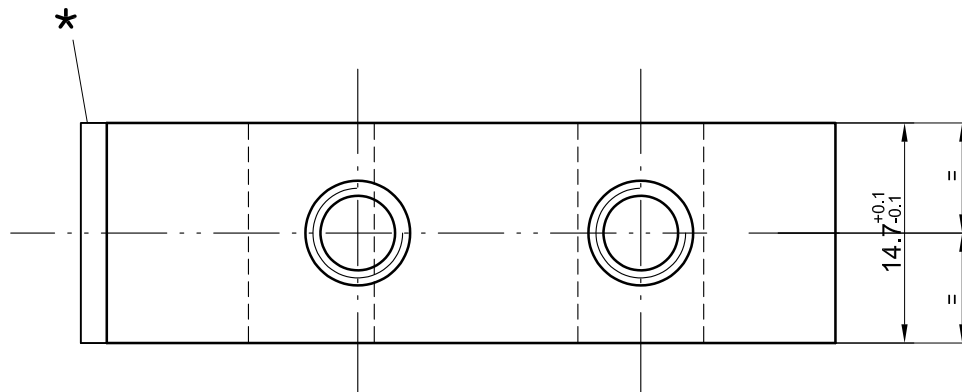

article no.:
Z918503

P 815400

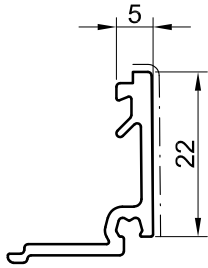

P 815401

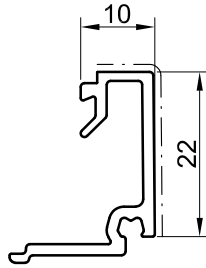

P 494400

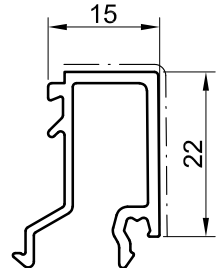

P 494401

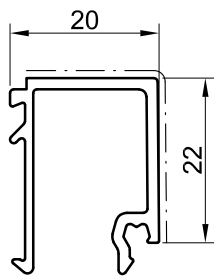

P 494402

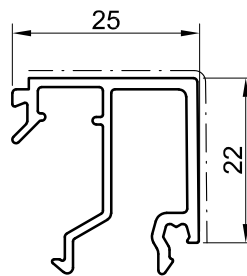

P 494403

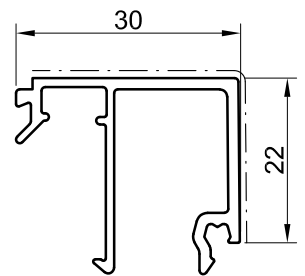

P 816608

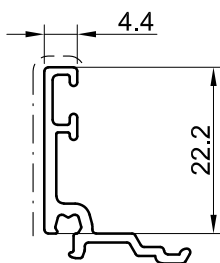

041000100

Scale 1:1

P 815400

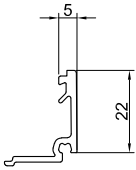

P 815401

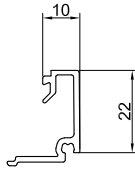

P 494400

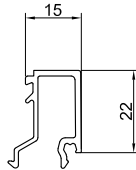

P 494401

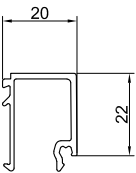

P 494402

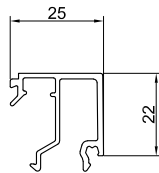

P 494403

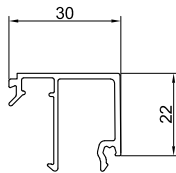

### Glazing gaskets for glazing beads

Glazing gaskets	external	internal			
		(A)	(B)	(C)	(D)
Art. no.	Z 914258	Z 917981	Z 914259	Z 914260	Z 914261
Gap dimension	5.5	3.5 - 5.5	4.5 - 6.5	5.5 - 7.5	6.5 - 9.5

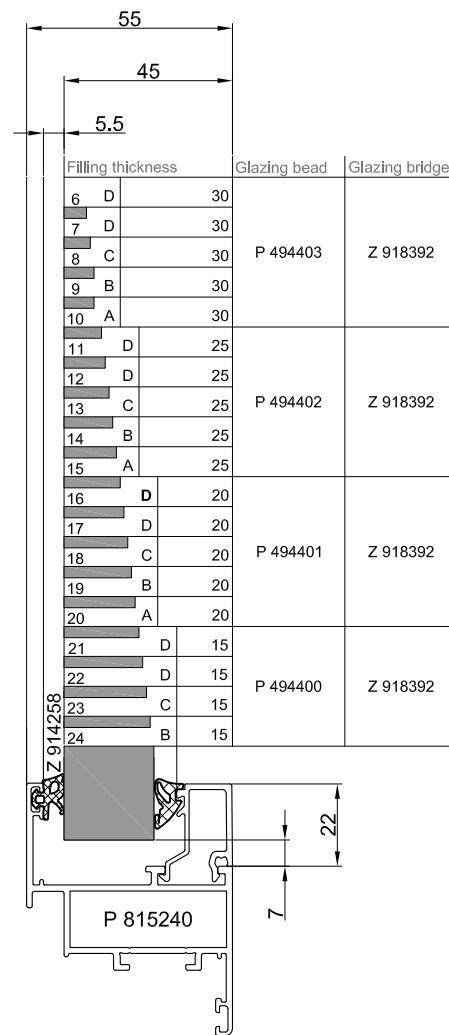
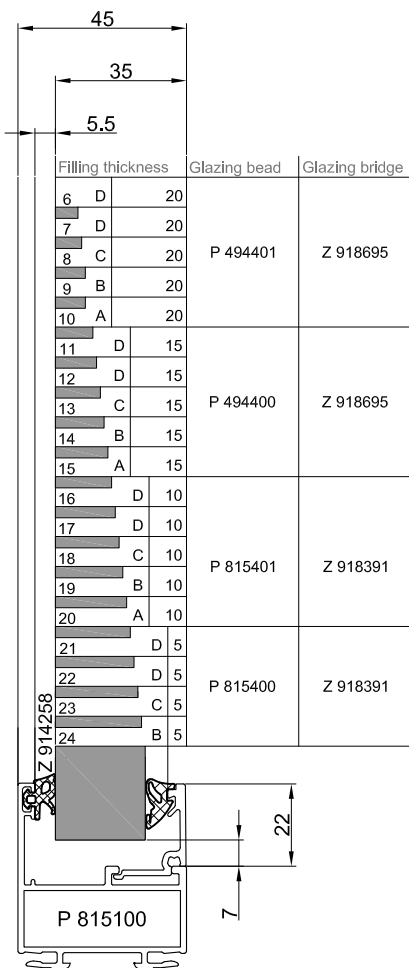

The specified panel thicknesses are nominal dimensions. When selecting the inner gasket, glass- and profile tolerances must be regarded. Possibly the next smaller or bigger inner gasket should be included.

Scale 1:2

P 816608

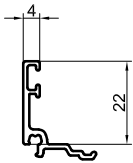

P 815400

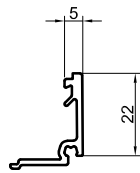

P 815401

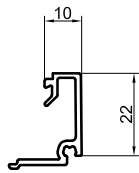

P 494400

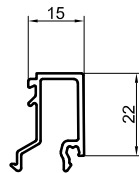

P 494401

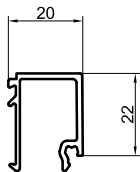

P 494402

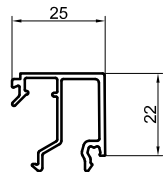

P 494403

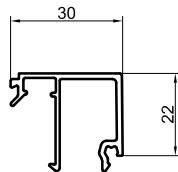

Glazing gaskets for glazing beads

Glazing gaskets	external	internal			
		(A)	(B)	(C)	(D)
Art. no.	Z 914258	Z 917981	Z 914259	Z 914260	Z 914261
Gap dimension	5.5	3.5 - 5.5	4.5 - 6.5	5.5 - 7.5	6.5 - 9.5

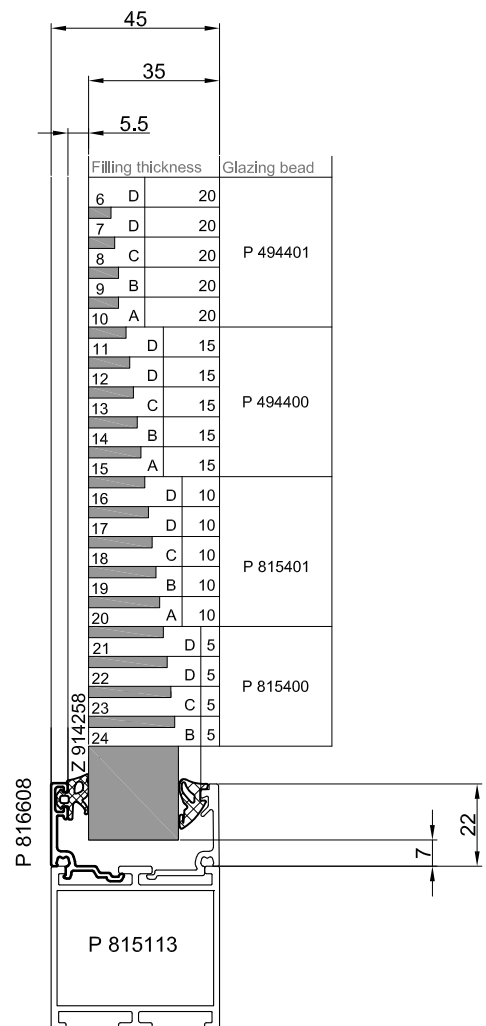

043000300

The specified panel thicknesses are nominal dimensions. When selecting the inner gasket, glass- and profile tolerances must be regarded. Possibly the next smaller or bigger inner gasket should be included.

Scale 1:2

### Opening inside

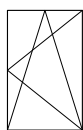

tilt/turn

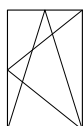

tilt before turn

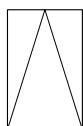

turn

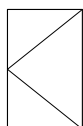

tilt

Profile Combination		Glass Dimension	
Frame	Vent	Width	height
P 815100 (P 815111) +	P815240	A - 147,4 (146,0) x	B - 147,4 (146,0)
P 815100 (P 815111) +	P815250	A - 203,0 (201,6) x	B - 203,0 (201,6)
P 815104 (P 815112) +	P815240	A - 178,8 (177,4) x	B - 178,8 (177,4)
P 815104 (P 815112) +	P815250	A - 234,4 (233,0) x	B - 234,4 (233,0)

### Opening inside

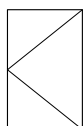

door

Profile Combination		Glass Dimension	
Frame	Vent	Width	height
P 815100 (P 815111) +	P815240	A - 147,4 (146,0) x	B - 134,0 (133,3)
P 815100 (P 815111) +	P815250	A - 203,0 (201,6) x	B - 189,6 (188,9)
P 815104 (P 815112) +	P815240	A - 178,8 (177,4) x	B - 149,7 (149,0)
P 815104 (P 815112) +	P815250	A - 234,4 (233,0) x	B - 205,3 (204,6)

### Opening outside

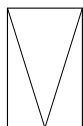

top hung

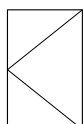

side hung

Profile Combination		Glass Dimension	
Frame	Vent	Width	height
P 815100 (P 815111) +	P815260	A - 172,4 (171,0) x	B - 172,4 (171,0)
P 815100 (P 815111) +	P815270	A - 199,4 (198,0) x	B - 199,4 (198,0)
P 815104 (P 815112) +	P815260	A - 203,8 (202,4) x	B - 203,8 (202,4)
P 815104 (P 815112) +	P815270	A - 230,8 (229,4) x	B - 230,8 (229,4)

A = Frame width  
B = Frame height

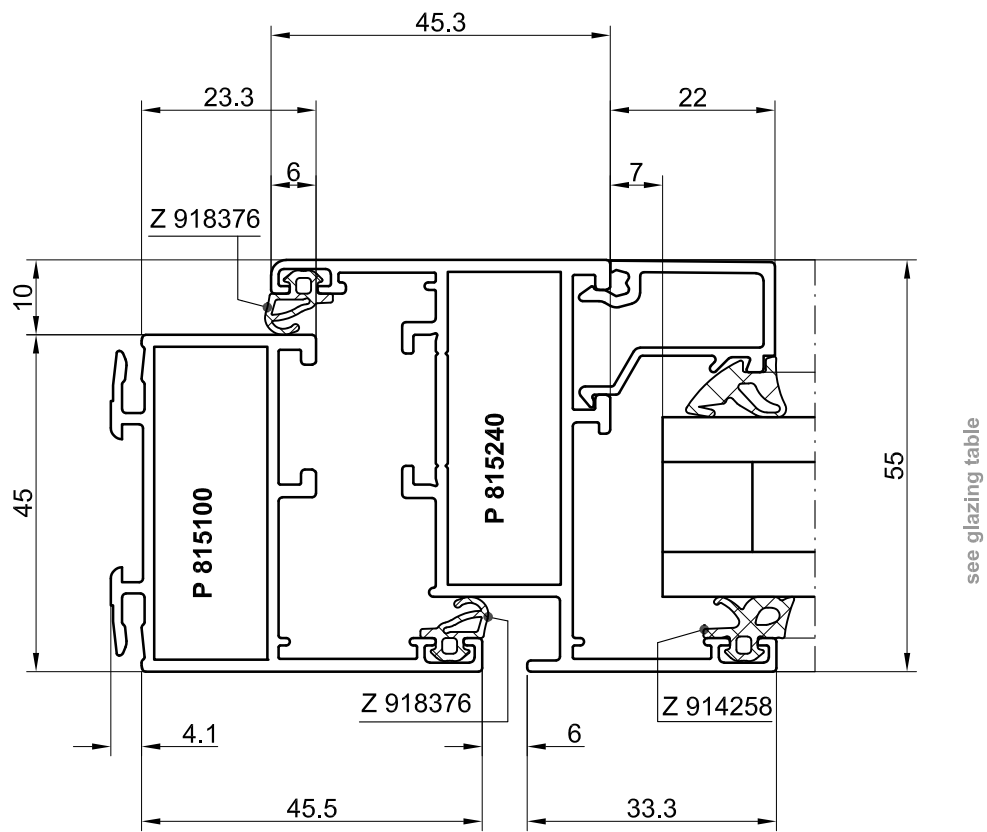
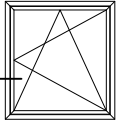

051000100

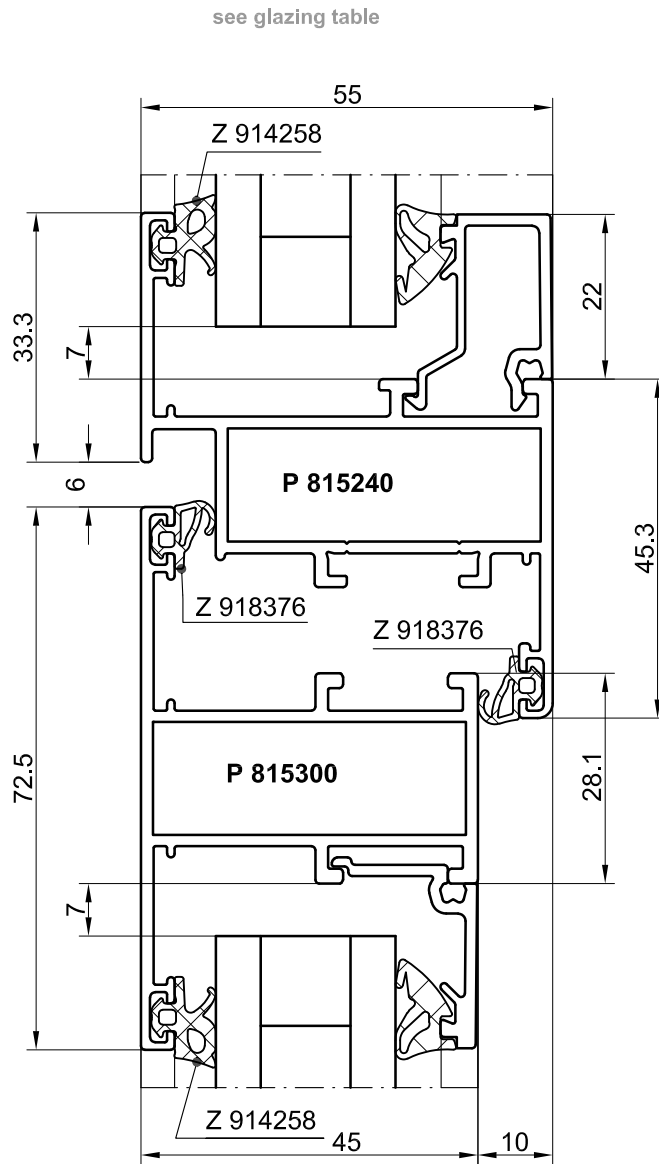
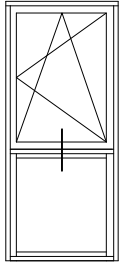

see glazing table

052000200



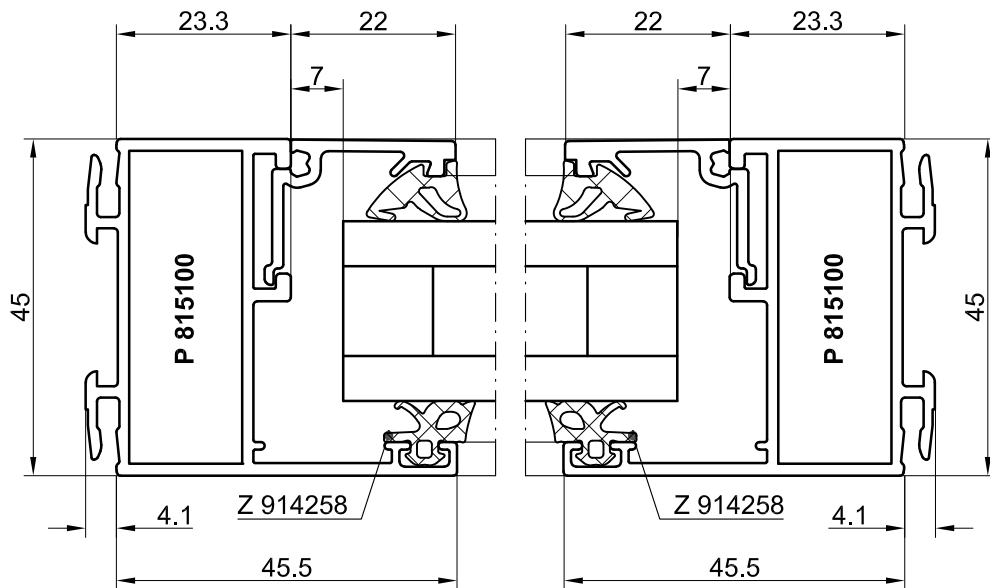
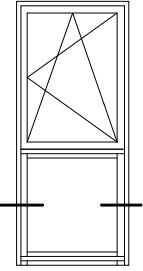

see glazing table

053000300

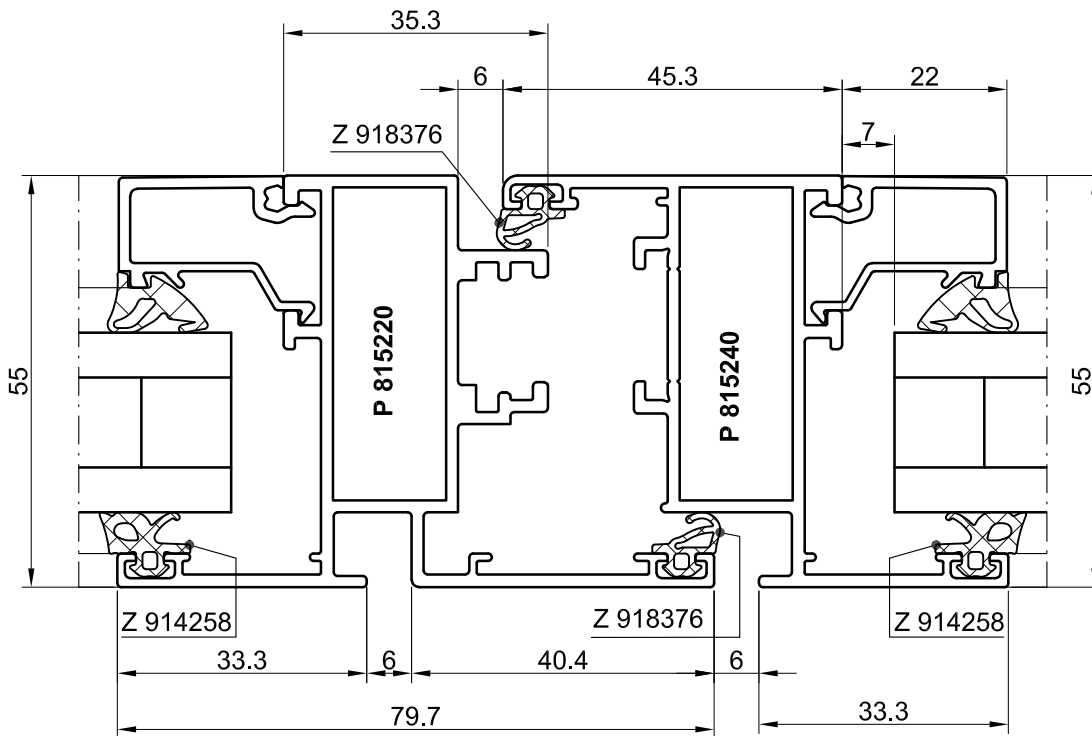
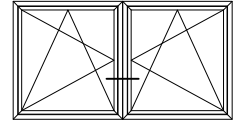

see glazing table

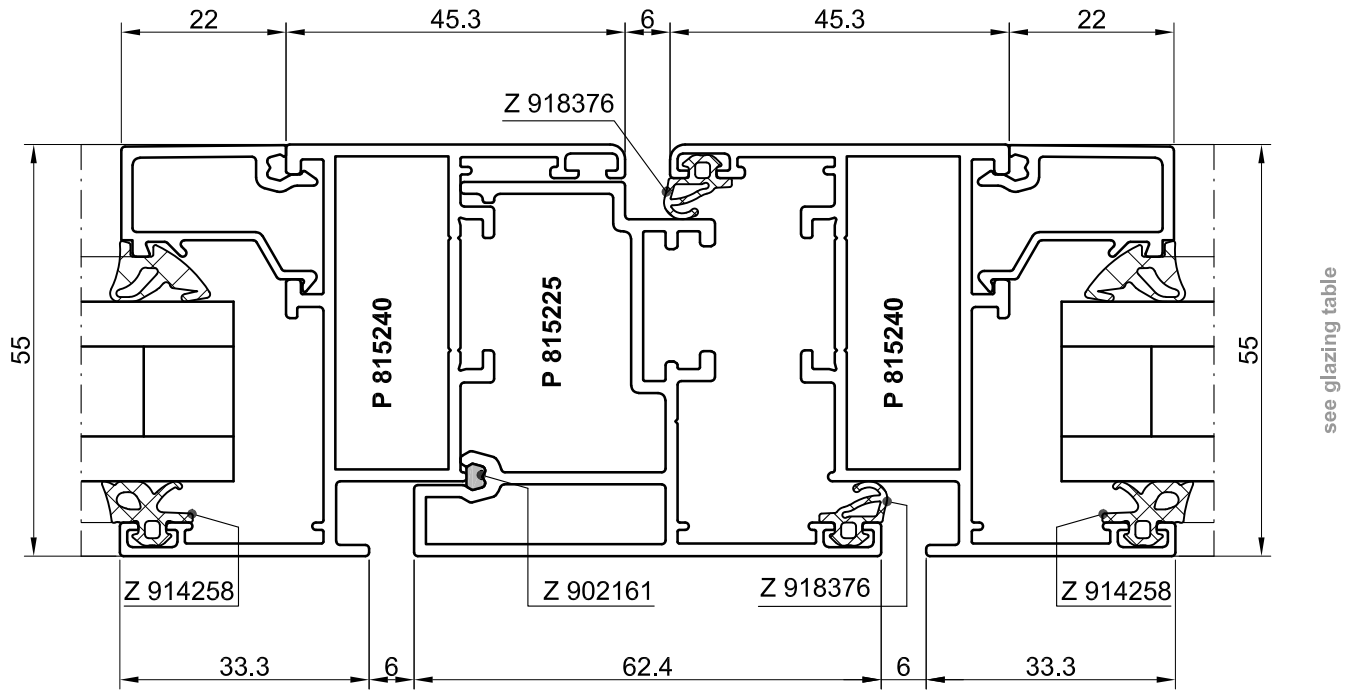
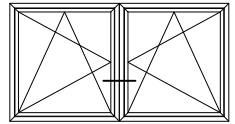

see glazing table

0550006500

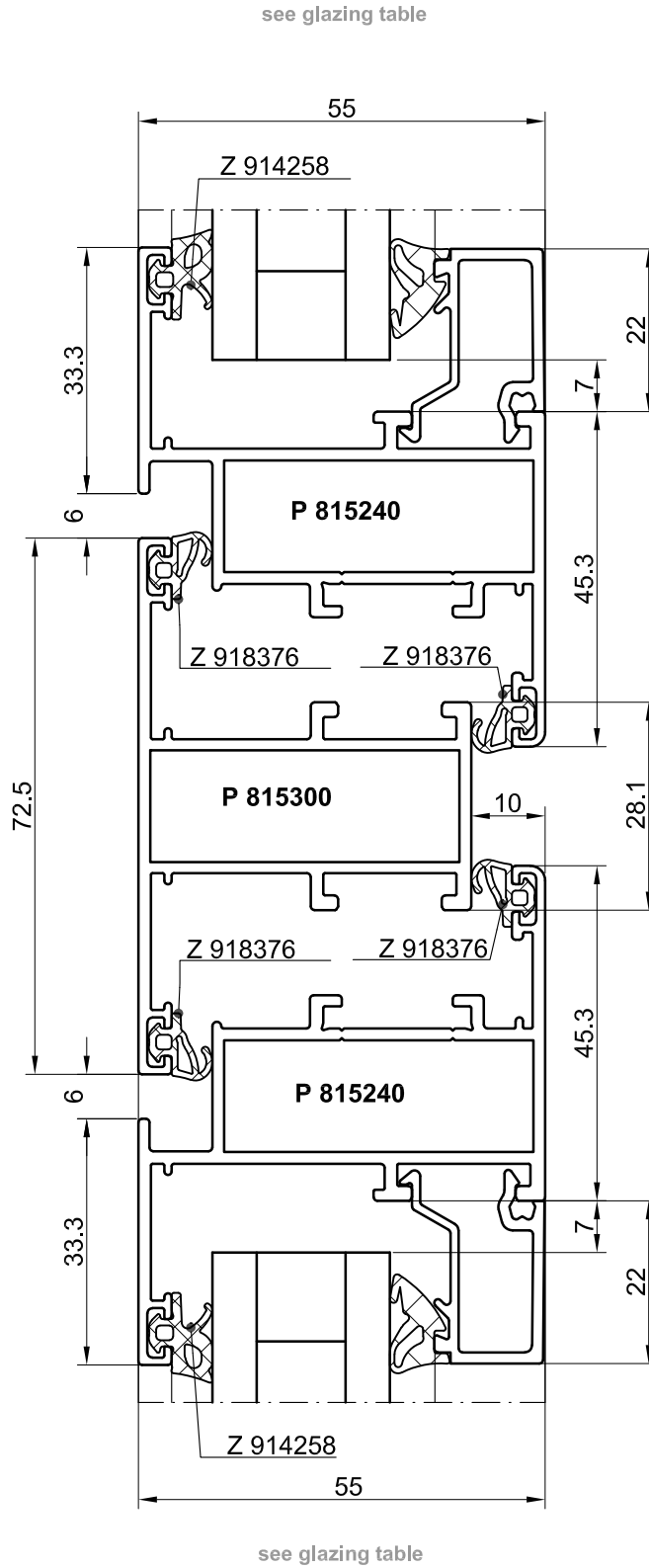
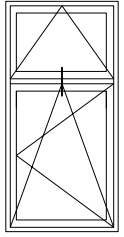

056000600

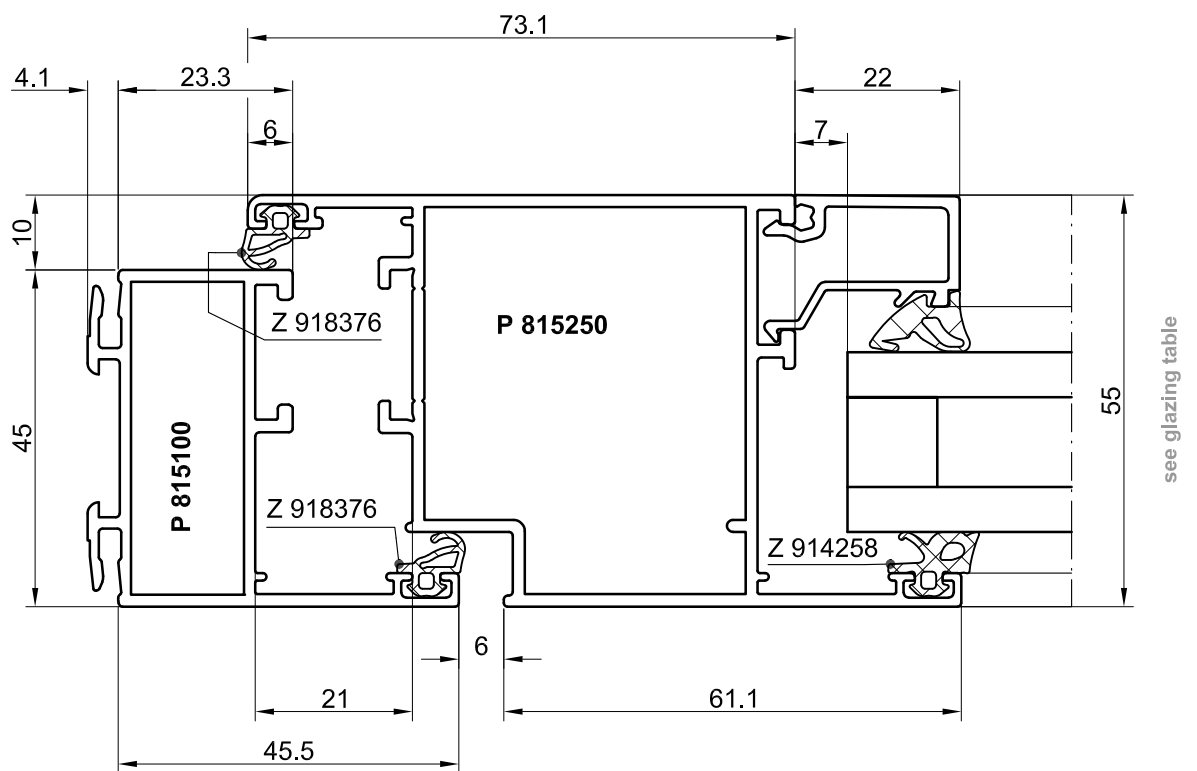
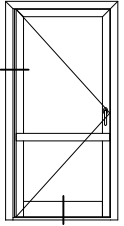

057000700

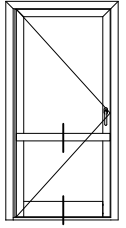
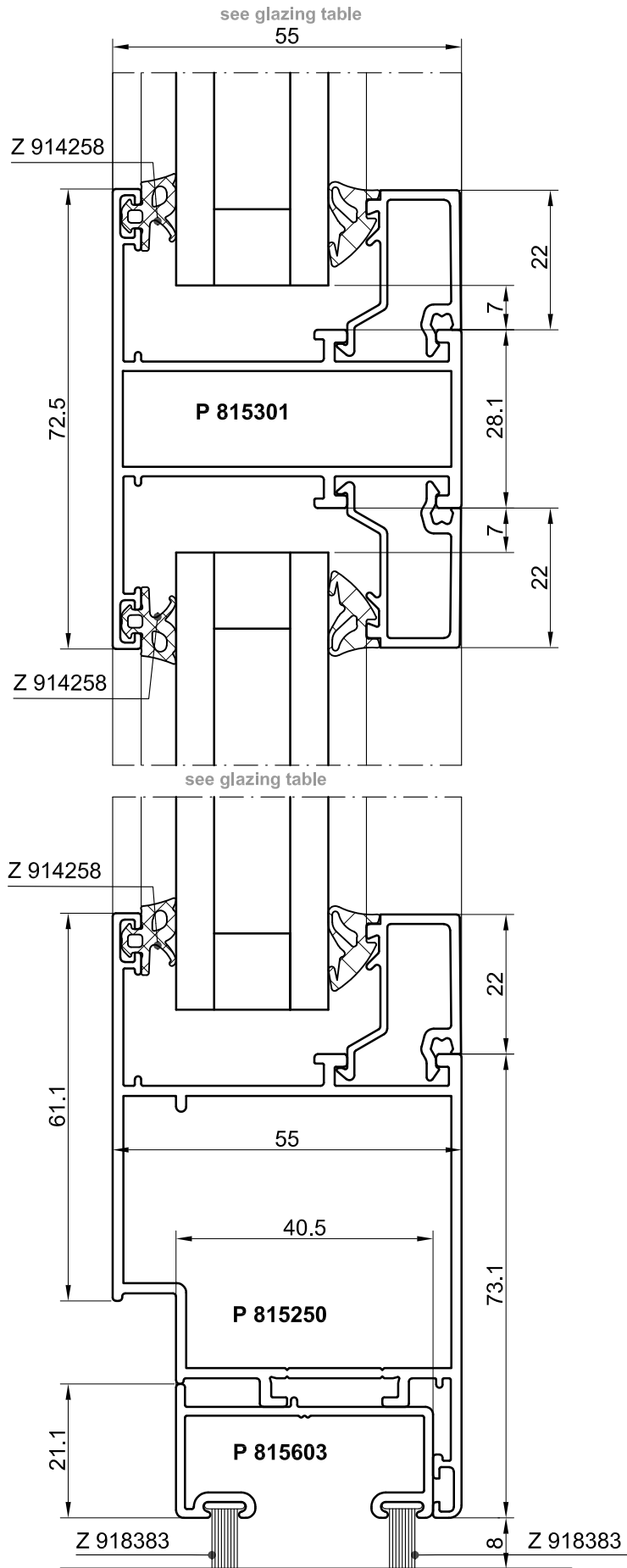

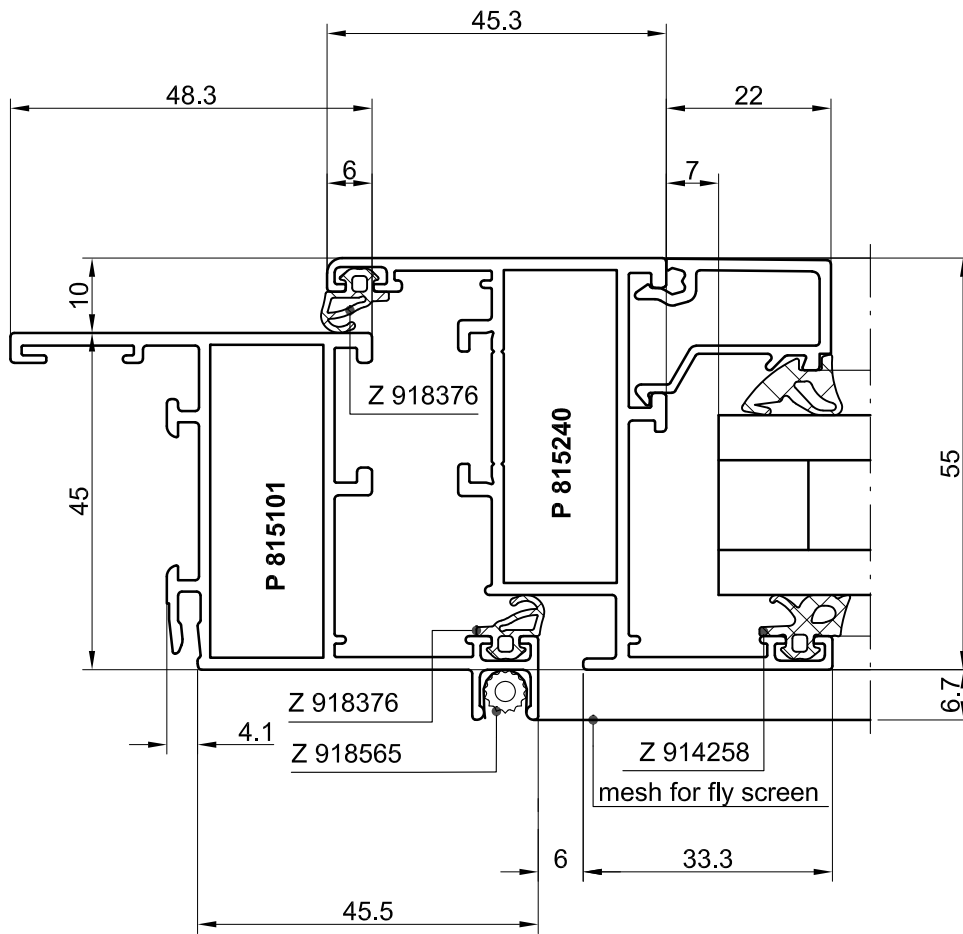
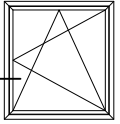

see glazing table

059000900

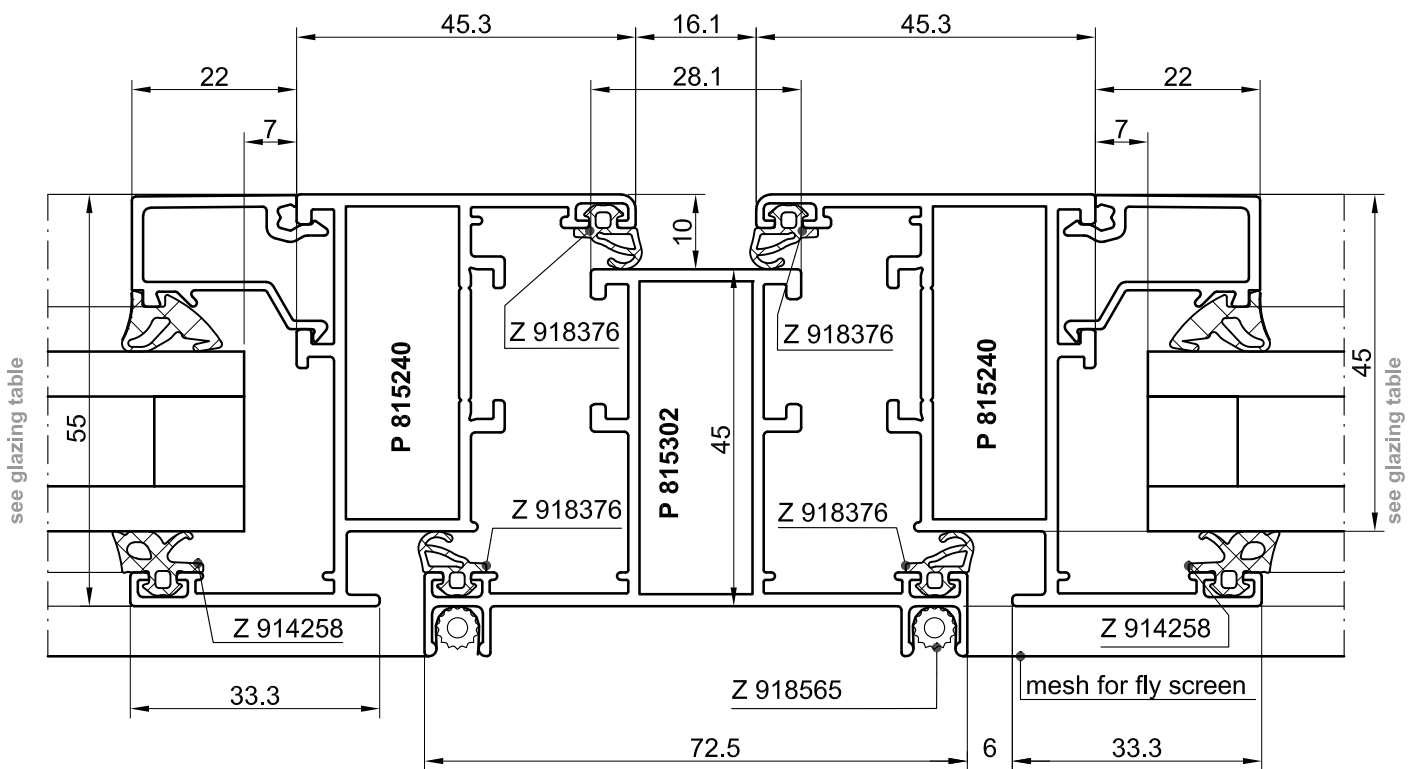
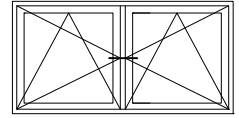



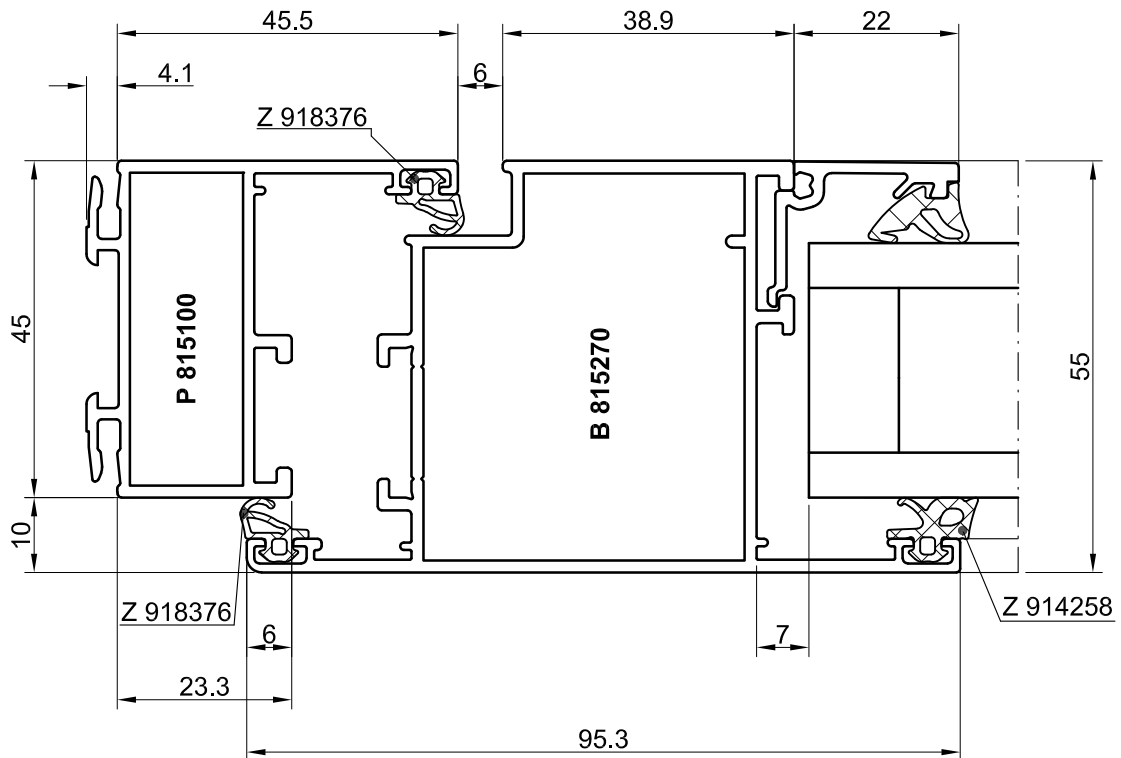
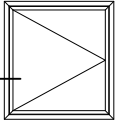

061001300

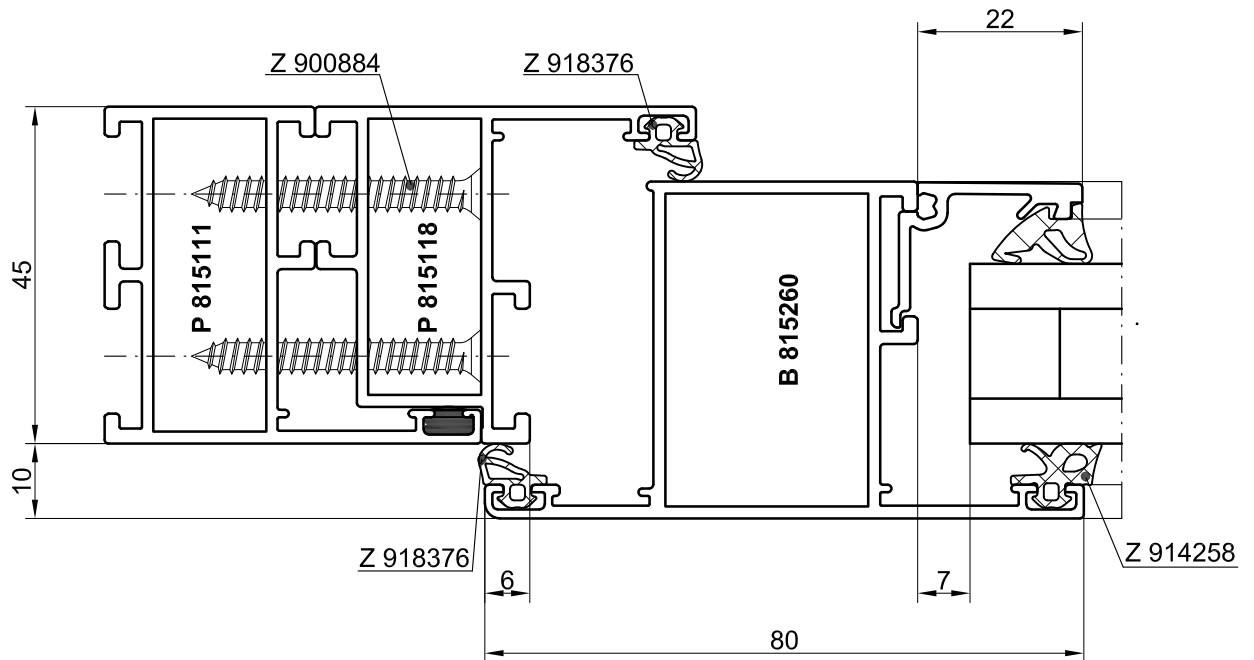
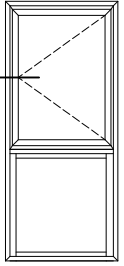

061001400

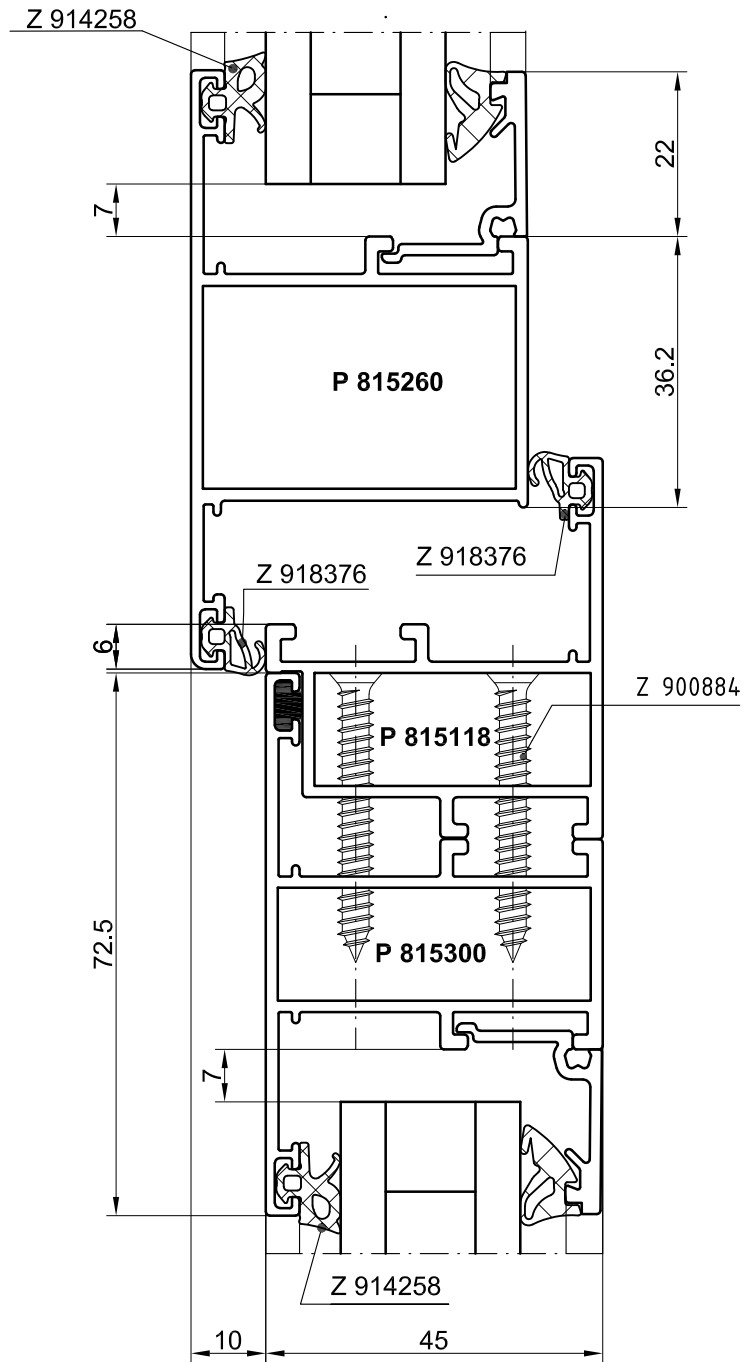
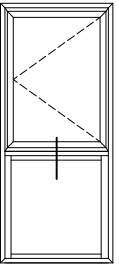

see glazing table

061001500

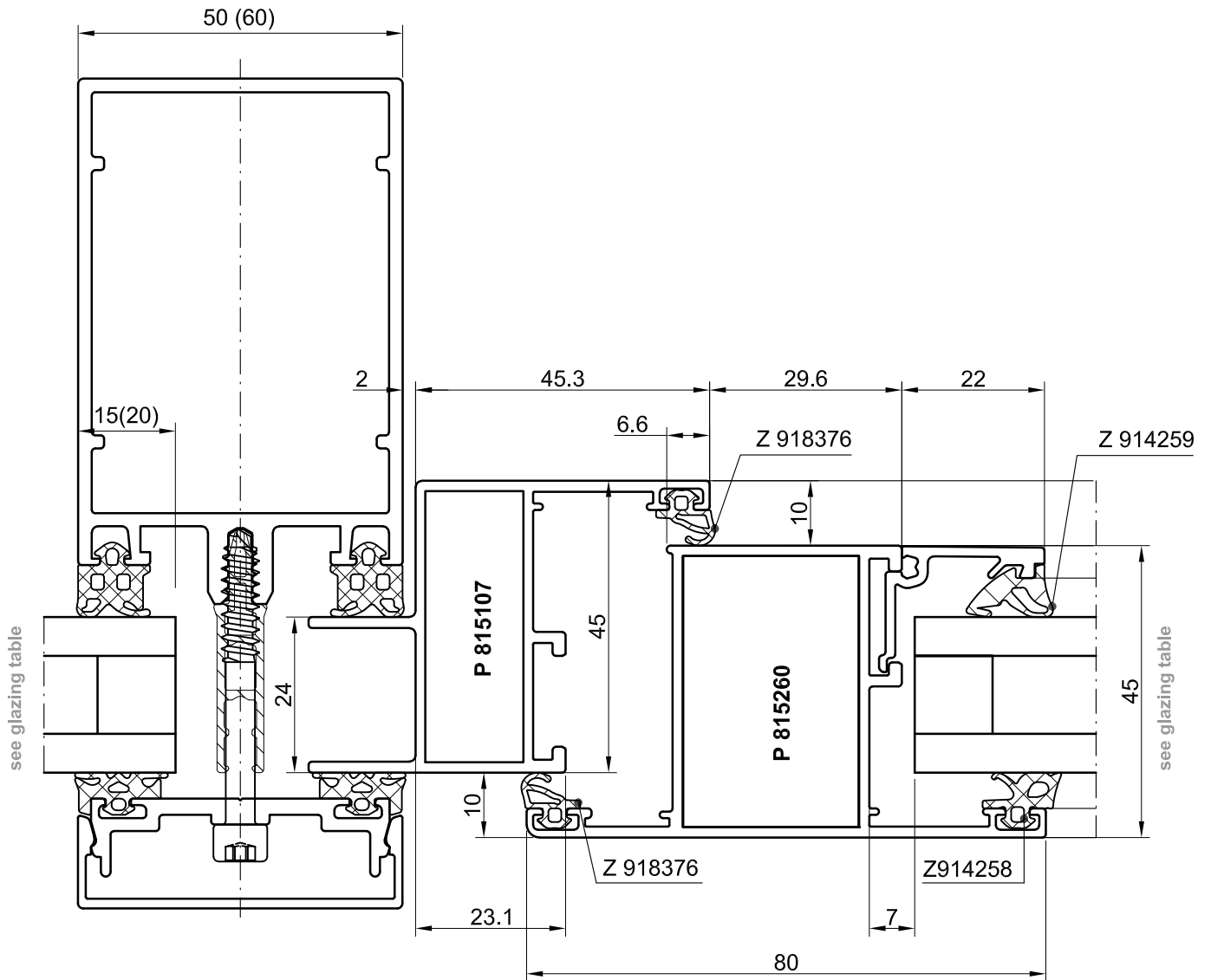
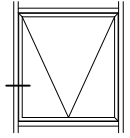

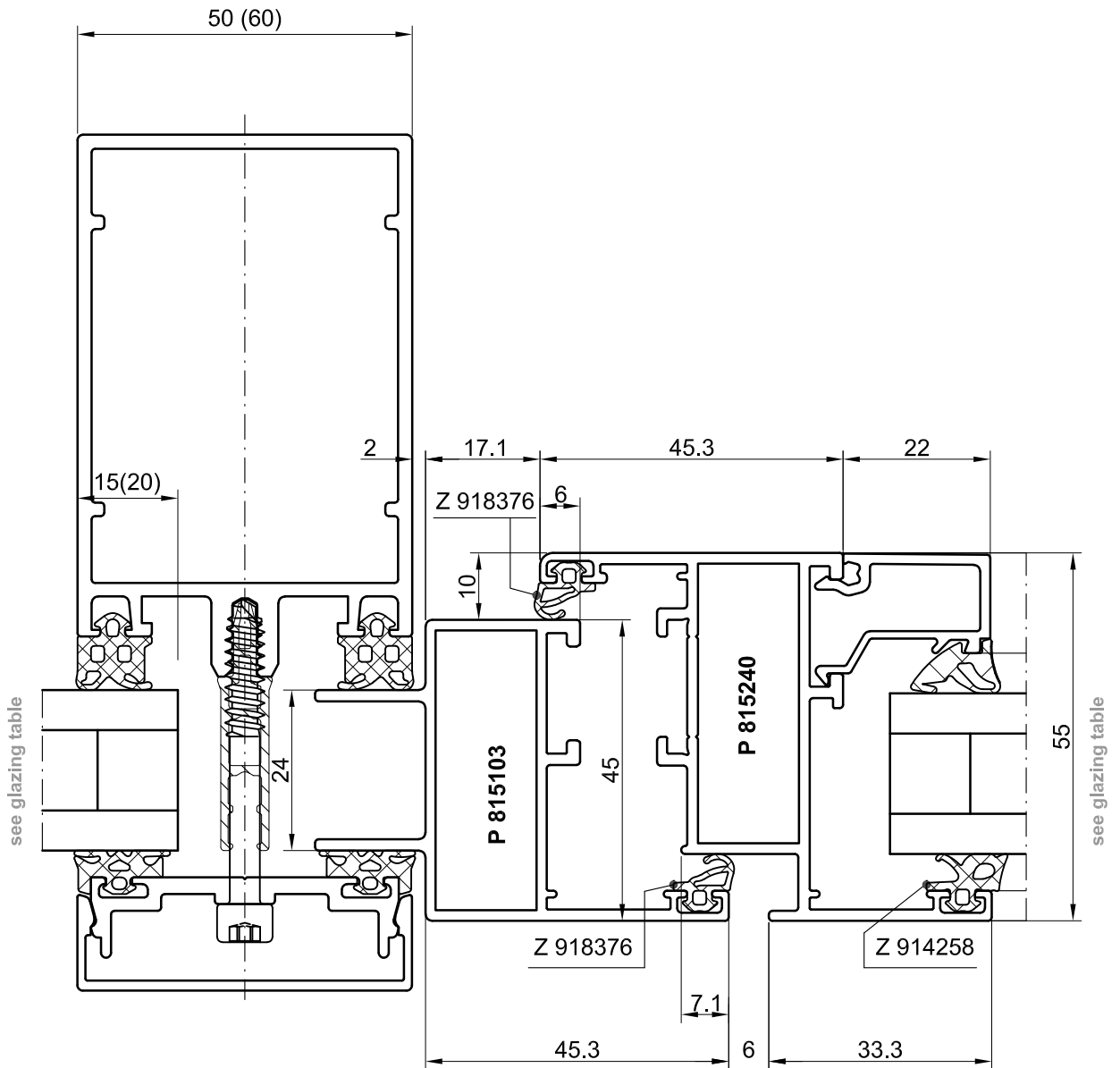
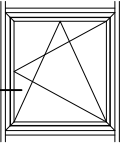

063001500

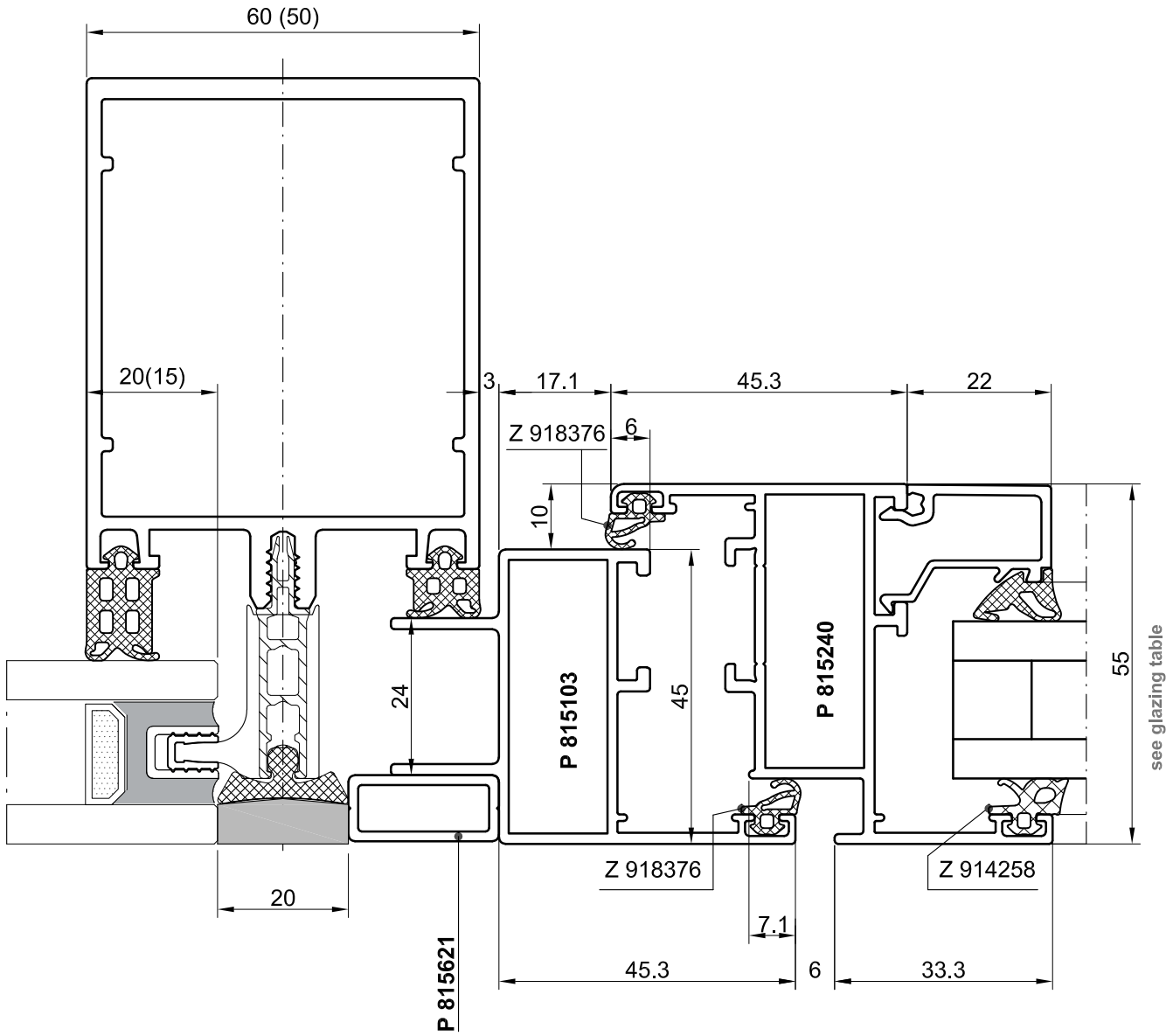
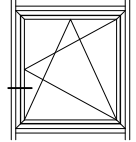

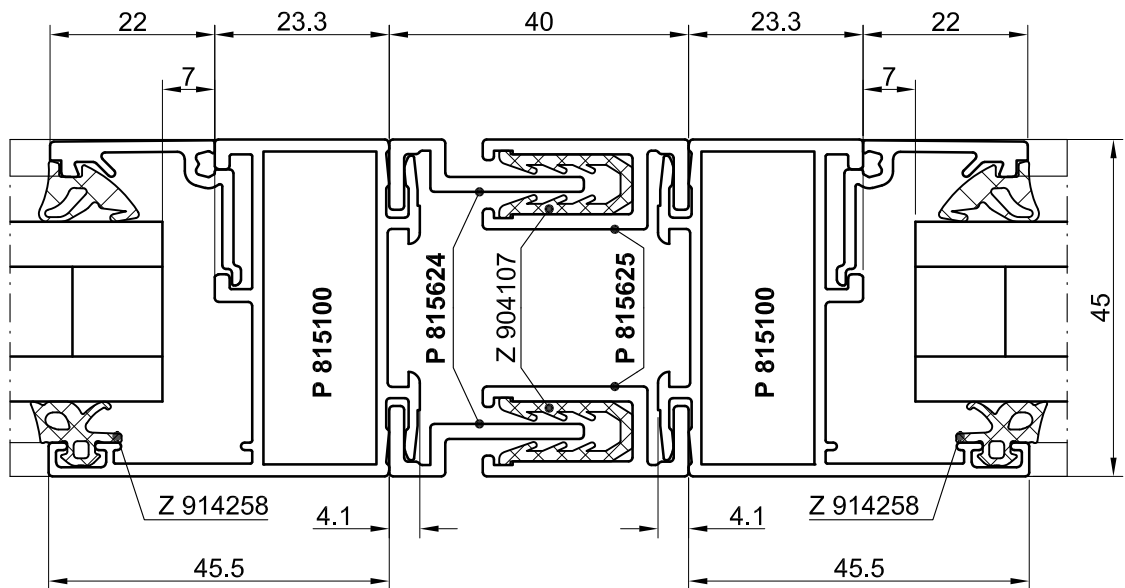
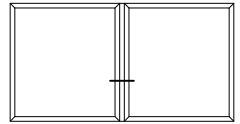

see glazing table

065001700







### Z 914258 22

Glazing gasket -outside-  
for gap dimensions of 5,5 mm  
EPDM, black  
Surface: siliconised



### Z 917981 22

Glazing gasket -internal-  
for gap dimensions of 3.5 - 5.5 mm  
EPDM, black  
Surface: siliconised



### Z 914259 22

Glazing gasket -internal-  
for gap dimensions of 4,5 - 6,5 mm  
EPDM, black  
Surface: siliconised



### Z 914260 22

Glazing gasket -internal-  
for gap dimensions of 5.5 - 7.5 mm  
EPDM, black  
Surface: siliconised

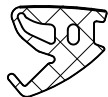

### Z 914261 22

Glazing gasket -internal and outside-  
for gap dimensions of 6.5 - 9.5 mm  
EPDM, black  
Surface: siliconised

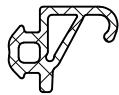

### Z 918376 22

Rebate/gasket for frame and sash  
profiles  
EPDM, black  
Surface: siliconised

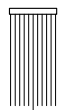

### Z 918383

Woven pile weather strip

081000100

Installation: refer to Processing Information

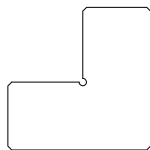

### Z 917772

Corner strengthening piece -external-  
**for sashes and fixed frame**,  
for stabilising the outer rebate,  
4 required for each sash

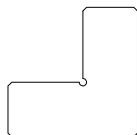

### Z 917773

Corner strengthening piece -external-  
**for fixed frame**,  
for stabilising the outer rebate,  
4 required for each sash

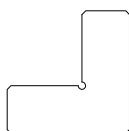

### Z 917774

Corner strengthening piece -internal-  
**for sashes**,  
for stabilising the sash lap  
4 required for each sash



### Z 900235

Lens-head self tapping screw  
B Ø3,9x16 DIN 7981

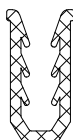

### Z 904107 25

Expansion gasket,  
EPDM, black  
suitable for expansion profiles  
for housing a material thickness  
of 2 - 3 mm



### Z 902161

Gasket cord rubber foam, dark grey,  
Ø 3 mm for sealing



### Z 900884

Screw,  
DIN 7982 4.8 x 40

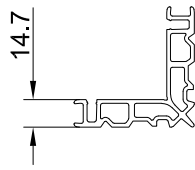

### Z 918394

Corner bracket 41,4 mm  
(from P 599343)

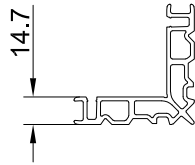

### Z 923245

Corner bracket 36,5 mm  
(from P 599343)

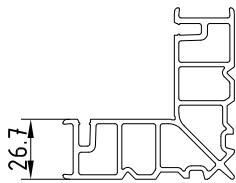

### Z 918491

Corner bracket 41,4 mm  
(from P 599348)

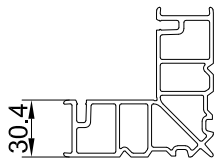

### Z 918601

Corner bracket 41,4 mm  
(from P 599364)

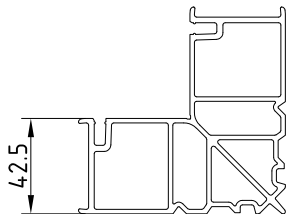

### Z 918395

Corner bracket 41,4 mm  
(from P 599346)



### Z 911049

Spring pin for t-bracket and corner  
bracket external,  
5 mm

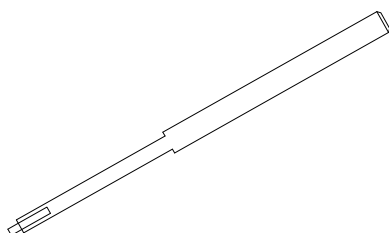

### Z 911187

Mandrel to drive in t-bracket for  
spring pin, r 5mm

083000300

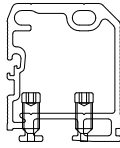

### Z 918502

T-bracket with 2 punch screws  
14,7 mm

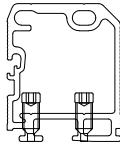

### Z 918702

T-bracket with 2 punch screws  
30,4 mm

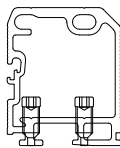

### Z 918703

T-bracket with 4 punch screws  
62,6 mm

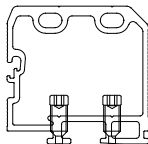

### Z 918503

T-bracket with 2 punch screws  
14,7 mm



### Z 914288

silicon gasket strip

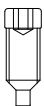

### Z 917691

punch screw M6

Installation: refer to Processing Information

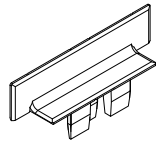

### Z 918834 22

Cover second sash  
ABS, black

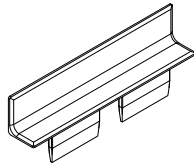

### Z 918835 22

Cover second sash  
ABS, black

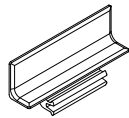

### Z 918836 22

Cover second sash  
ABS, black

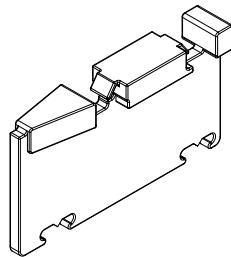

### Z 918561

Cover for profile P 815603 under  
P 815250

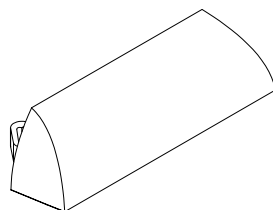

### Z 918390

Drain cap with membrane for  
covering the water drainage slots  
in the fixed frame, slot dimensions:  
6 x 30 mm

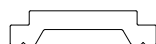

### K 910137

Operating rod

0850006500

Installation: refer to Processing Information

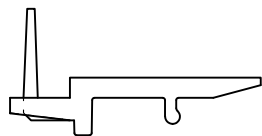

### Z 918391

Glazing bridge for the **fixed frame** profiles (Glass 16-24 mm)

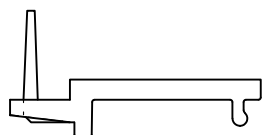

### Z 918392

Glazing bridge for the **sash** profiles

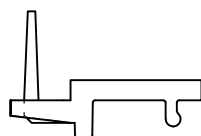

### Z 918695

Glazing bridge for the **fixed frame** profiles (Glass 6-15 mm)

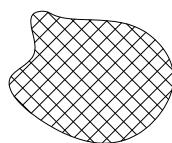

### Building site

Mesh,  
for fly screen



### Z 918565

PVC gasket for fly screen

Installation: refer to Processing Information

### Two-component glue



#### Z 911737

Two-component glue in dual cartridges, 620 ml PU = 6



#### Z 911738

Statik mixer, required for dual cartridges PU = 50



#### Z 912717

Sealing material, grey, EPDM suitable, processing temperature 5 - 40 ° Celsius PU = 310 ml in foil cartridge



#### Z 912718

Sealing material, black, EPDM suitable, processing temperature 5 - 40 ° Celsius PU = 310 ml in foil cartridge



#### Z 903941

EPDM - glue, black for sealing mitre joints on glazing gaskets processing temperature 12°-40°C, durability 6 months PU = 200 g tube

PU = packing unit





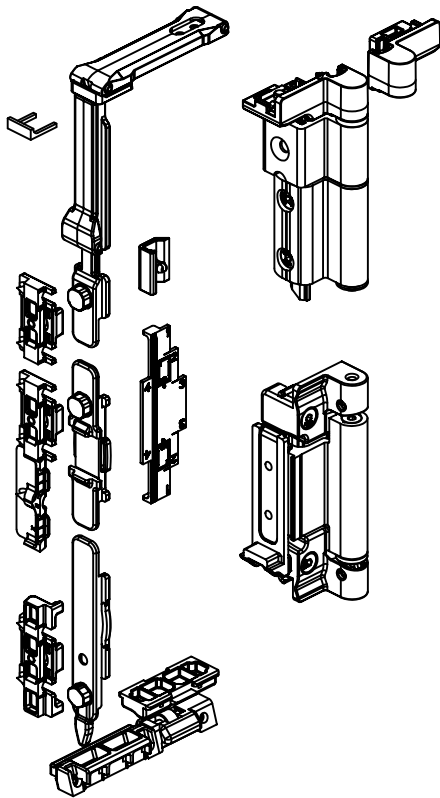

① **Z 997412**

Basic Kit with anti-false manouvre on the cremone bolt - load 130 kg

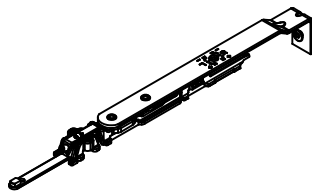
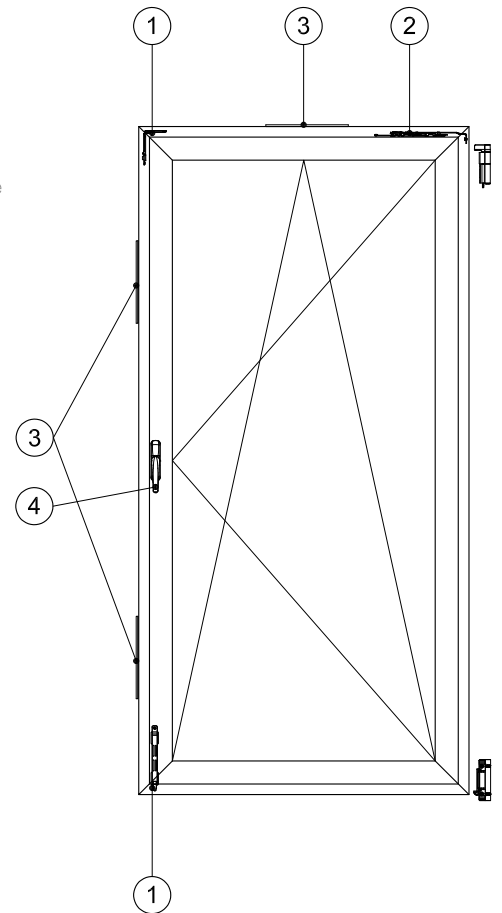

②

Art. no.	length [mm]
<b>Z 918617</b>	359 - 451
<b>Z 918618</b>	450 - 651
<b>Z 918619</b>	650 - 1701

Short arm

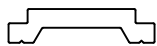

③ **K 910137**

Polyamid rod  
Coil from 250 m

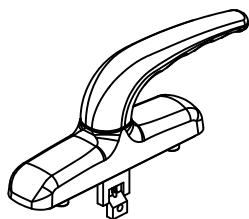

④ **Z 918621**

Cremone bolt comfort for tilt and turn

101000100

Installation: refer to processing information

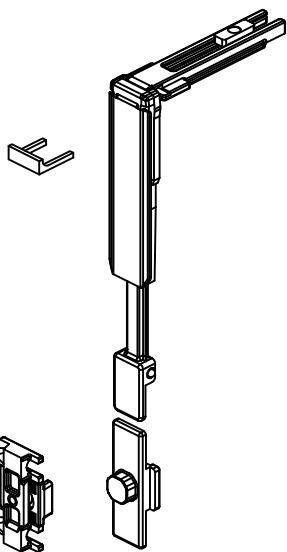

### Z 997413

Horizontal lower and vertical supplementary closing

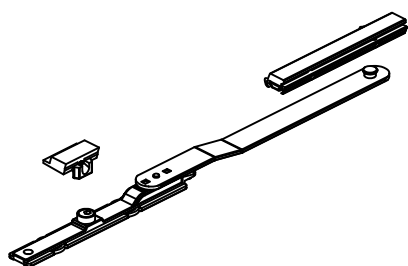

### Z 918620

Supplementary arm for sash width >1200 mm

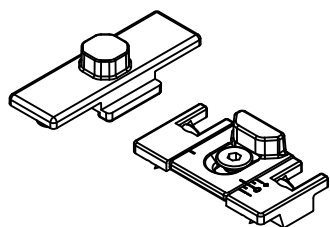

### Z 997414

Supplementary closing point

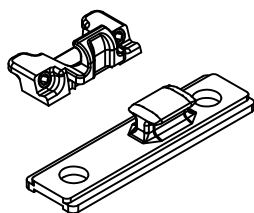

### Z 997415

Horizontal lower supplementary closing for sash width >1200 mm

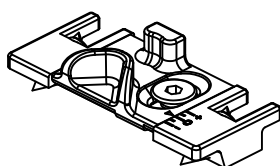

### Z 918622

Microventilation

Installation: refer to processing information

Leaf max weight 130Kg

2400	100%	100%	100%	100%	100%	100%	100%	100%	100%	100%	100%	100%
2300	100%	100%	100%	100%	100%	100%	100%	100%	100%	100%	100%	100%
2200	100%	100%	100%	100%	100%	100%	100%	100%	100%	100%	100%	100%
2100	100%	100%	100%	100%	100%	100%	100%	100%	100%	100%	100%	100%
2000	100%	100%	100%	100%	100%	100%	100%	100%	100%	100%	100%	100%
1900	100%	100%	100%	100%	100%	100%	100%	100%	100%	100%	100%	100%
1800	100%	100%	100%	100%	100%	100%	100%	100%	100%	100%	100%	100%
1700	100%	100%	100%	100%	100%	100%	100%	100%	100%	100%	100%	100%
1600	100%	100%	100%	100%	100%	100%	100%	100%	100%	100%	100%	100%
1500	100%	100%	100%	100%	100%	100%	100%	100%	100%	100%	100%	95%
1400	100%	100%	100%	100%	100%	100%	100%	100%	100%	100%	95%	90%
1300	100%	100%	100%	100%	100%	100%	100%	100%	100%	95%	90%	75%
1200	100%	100%	100%	100%	100%	100%	100%	100%	100%	90%	75%	60%
1100	100%	100%	100%	100%	100%	100%	100%	100%	90%	75%	60%	45%
1000	100%	100%	100%	100%	100%	100%	100%	90%	75%	60%	45%	25%
900	100%	100%	100%	100%	100%	100%	90%	75%	60%	45%	25%	X
800	100%	100%	100%	100%	100%	90%	75%	60%	45%	25%	X	X
700	100%	100%	100%	100%	90%	75%	60%	45%	X	X	X	X
600	100%	100%	100%	90%	75%	60%	45%	X	X	X	X	X
450	100%	100%	90%	75%	60%	X	X	X	X	X	X	X
H \ L	370	400	500	600	700	800	900	1000	1100	1200	1300	1400

Example: 80% x 130kg= 104Kg

x Not feasible

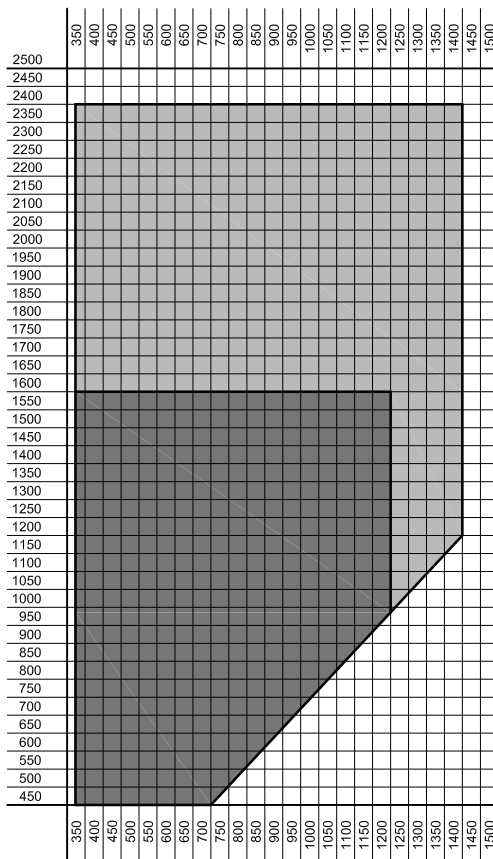

P 815240

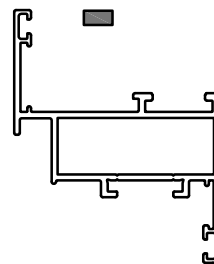

P 815250

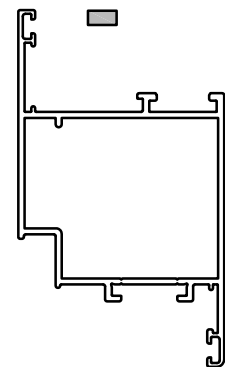

FB [sash width] must not exceed 125% of FH [sash height]

For additional locks see the following fitting variants

103000300



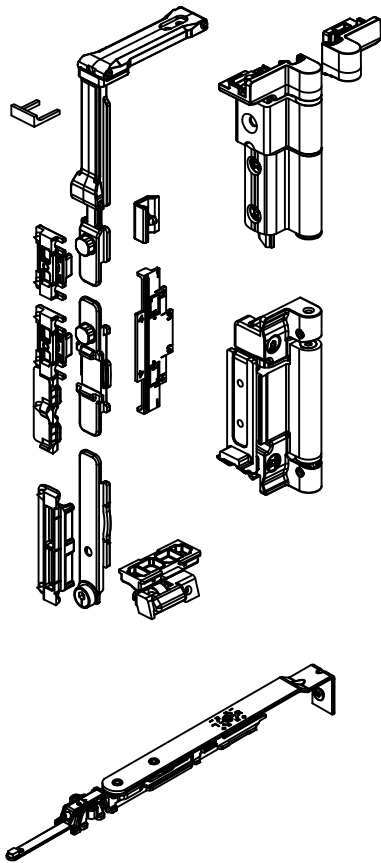

### Z 997416

- ① Logica Basic Kit with anti-false manoeuvre on the cremone bolt - load 130 kg

②

Art. no.	length [mm]
<b>Z 918623</b>	359 - 451
<b>Z 918624</b>	450 - 651
<b>Z 918625</b>	650 - 1701

Short arm

### ③ K 910137

Polyamid rod  
Coil from 250 m

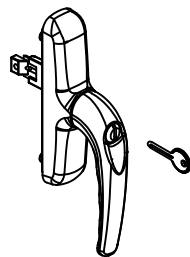
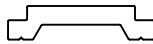

### Z 918630

Cremone bolt comfort for tilt and turn - lockable right

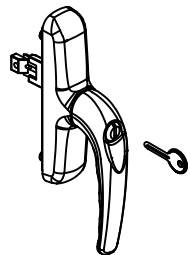

### Z 918616

Cremone bolt comfort for tilt and turn - lockable left

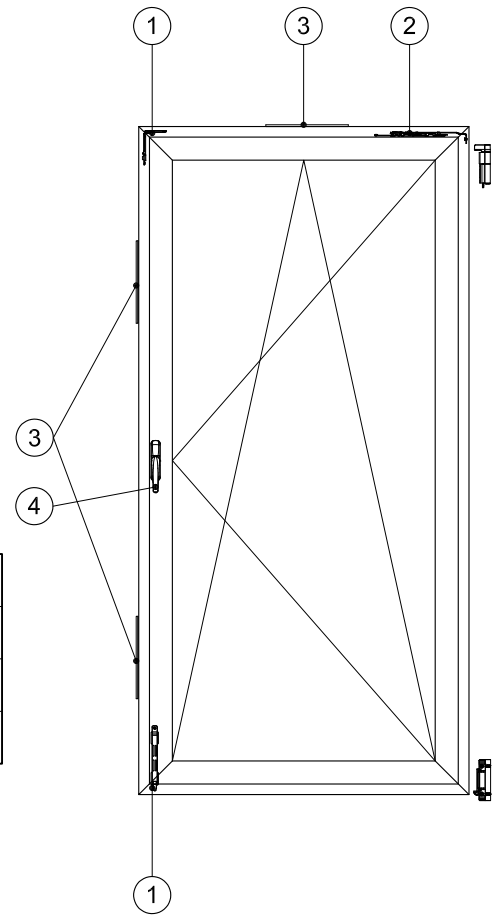

105006500

Installation: refer to processing information

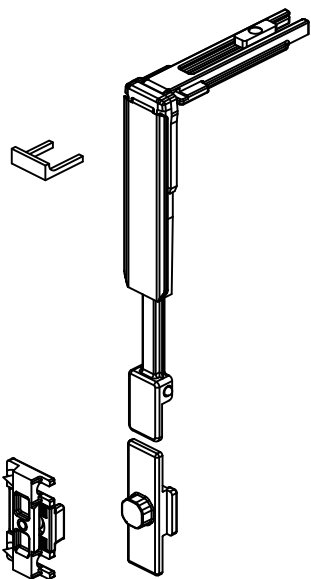

### Z 997413

Horizontal lower and vertical supplementary closing

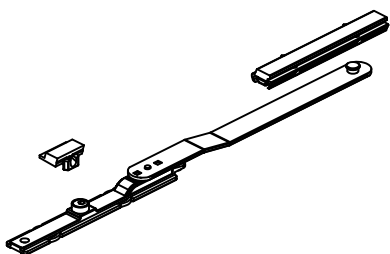

### Z 918626

Tilt first supplementary arm for sash width >1200 mm

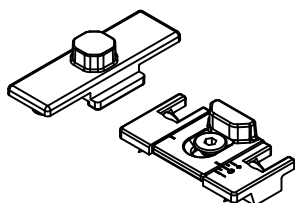

### Z 997414

Supplementary closing point

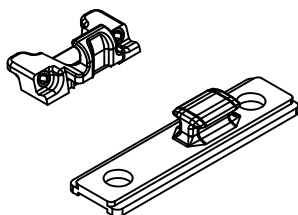

### Z 997415

Horizontal lower supplementary closing for sash width >1200 mm

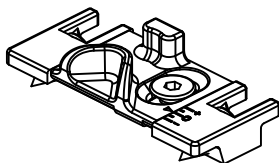

### Z 918622

Microventilation

Installation: refer to processing information

Leaf max weight 130Kg

2400	100%	100%	100%	100%	100%	100%	100%	100%	100%	100%	100%	100%	
2300	100%	100%	100%	100%	100%	100%	100%	100%	100%	100%	100%	100%	
2200	100%	100%	100%	100%	100%	100%	100%	100%	100%	100%	100%	100%	
2100	100%	100%	100%	100%	100%	100%	100%	100%	100%	100%	100%	100%	
2000	100%	100%	100%	100%	100%	100%	100%	100%	100%	100%	100%	100%	
1900	100%	100%	100%	100%	100%	100%	100%	100%	100%	100%	100%	100%	
1800	100%	100%	100%	100%	100%	100%	100%	100%	100%	100%	100%	100%	
1700	100%	100%	100%	100%	100%	100%	100%	100%	100%	100%	100%	100%	
1600	100%	100%	100%	100%	100%	100%	100%	100%	100%	100%	100%	100%	
1500	100%	100%	100%	100%	100%	100%	100%	100%	100%	100%	100%	95%	
1400	100%	100%	100%	100%	100%	100%	100%	100%	100%	100%	95%	90%	
1300	100%	100%	100%	100%	100%	100%	100%	100%	100%	95%	90%	75%	
1200	100%	100%	100%	100%	100%	100%	100%	100%	100%	90%	75%	60%	
1100	100%	100%	100%	100%	100%	100%	100%	100%	90%	75%	60%	45%	
1000	100%	100%	100%	100%	100%	100%	100%	90%	75%	60%	45%	25%	
900	100%	100%	100%	100%	100%	100%	90%	75%	60%	45%	25%	X	
800	100%	100%	100%	100%	100%	90%	75%	60%	45%	25%	X	X	
700	100%	100%	100%	100%	90%	75%	60%	45%	X	X	X	X	
600	100%	100%	100%	90%	75%	60%	45%	X	X	X	X	X	
450	100%	100%	90%	75%	60%	X	X	X	X	X	X	X	
H	L	370	400	500	600	700	800	900	1000	1100	1200	1300	1400

Example: 80% x 130kg= 104Kg

x Not feasible

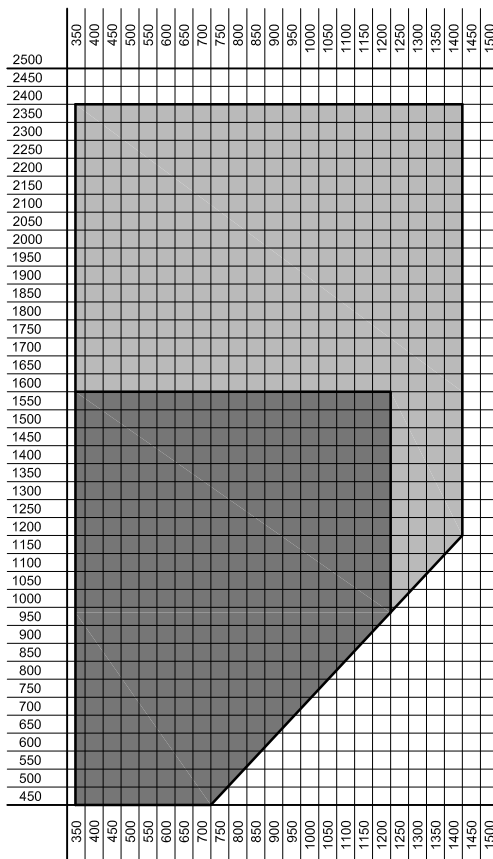

P 815240

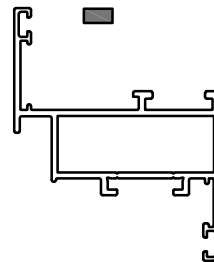

P 815250

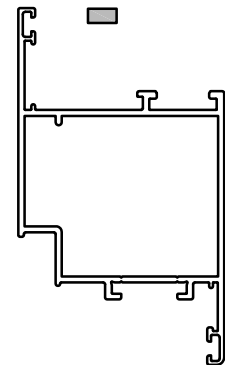

FB [sash width] must not exceed 125% of FH [sash height]

For additional locks see the following fitting variants

107000700





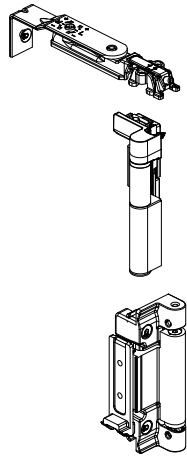

① Z 997422

Kit for secondary sash  
load 130 kg

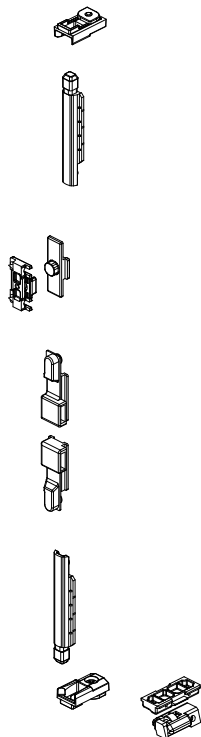

② Z 997421

Kit for turn sash

### Solution A

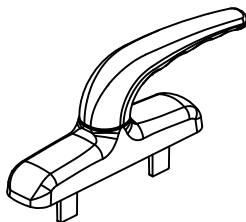
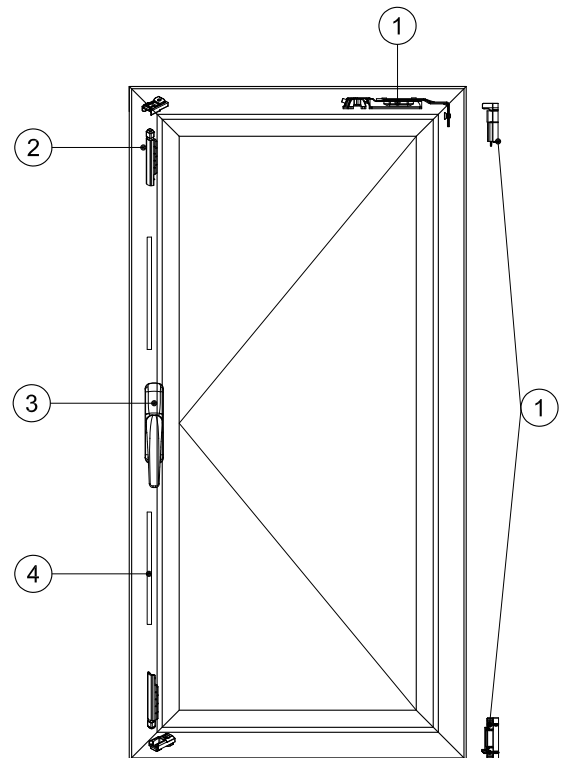

③ Z 918627

Cremone bolt comfort with  
inter-axes 84,5-92-98-104 mm

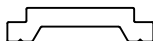

④ K 910137

Polyamid rod  
Coil from 250 m

109000900

Installation: refer to processing information

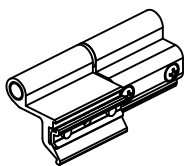

①a **Z 997253**

Fast mounting hinge (2 parts)-  
load 80 kg  
Packing unit (2x)

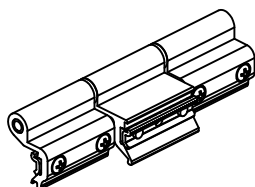

①b **Z 997247**

Fast mounting hinge (3 parts)-  
load 100 kg  
Packing unit (2x)

### Solution B

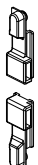
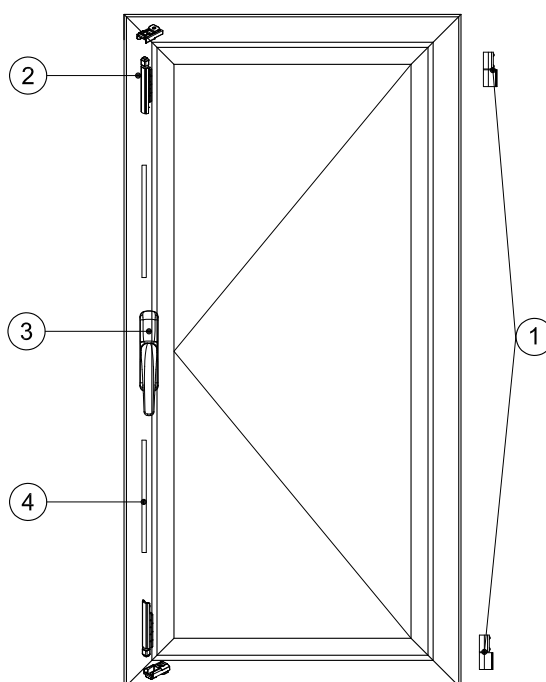

② **Z 997421**

Kit for secondary sash

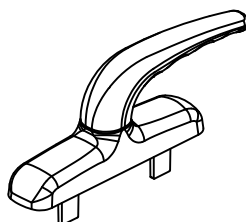

③ **Z 918627**

Cremona bolt comfort with  
inter-axes 84,5-92-98-104 mm

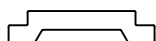

④ **K 910137**

Polyamid rod  
Coil from 250 m

Installation: refer to processing information

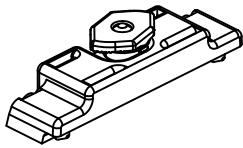

**Z 997423**

Sash stopper

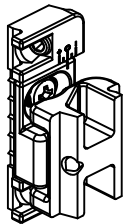

**Z 997424**

Additional intermediate third closing point

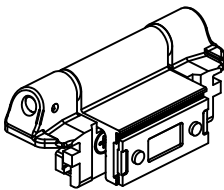

**Z 997417**

Comb Hinge - Load 120 kg

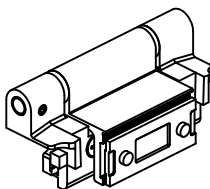

**Z 997418**

Comb Hinge - Load 80 kg

Leaf max weight 130Kg

2400	100%	100%	100%	100%	100%	100%	100%	100%	100%	100%
2300	100%	100%	100%	100%	100%	100%	100%	100%	100%	100%
2200	100%	100%	100%	100%	100%	100%	100%	100%	100%	100%
2100	100%	100%	100%	100%	100%	100%	100%	100%	100%	100%
2000	100%	100%	100%	100%	100%	100%	100%	100%	100%	100%
1900	100%	100%	100%	100%	100%	100%	100%	100%	100%	100%
1800	100%	100%	100%	100%	100%	100%	100%	100%	100%	100%
1700	100%	100%	100%	100%	100%	100%	100%	100%	100%	100%
1600	100%	100%	100%	100%	100%	100%	100%	100%	100%	100%
1500	100%	100%	100%	100%	100%	100%	100%	100%	100%	100%
1400	100%	100%	100%	100%	100%	100%	100%	100%	100%	100%
1300	100%	100%	100%	100%	100%	100%	100%	100%	100%	95%
1200	100%	100%	100%	100%	100%	100%	100%	100%	100%	90%
1100	100%	100%	100%	100%	100%	100%	100%	100%	90%	75%
1000	100%	100%	100%	100%	100%	100%	100%	90%	75%	60%
900	100%	100%	100%	100%	100%	100%	90%	75%	60%	45%
800	100%	100%	100%	100%	100%	90%	75%	60%	45%	25%
700	100%	100%	100%	100%	90%	75%	60%	45%	X	X
600	100%	100%	100%	90%	75%	60%	45%	X	X	X
450	100%	100%	90%	75%	60%	X	X	X	X	X
H \ L	370	400	500	600	700	800	900	1000	1100	1200

Example: 80% x 130kg= 104Kg

### Solution A

Z 997422 max. weight 130 kg

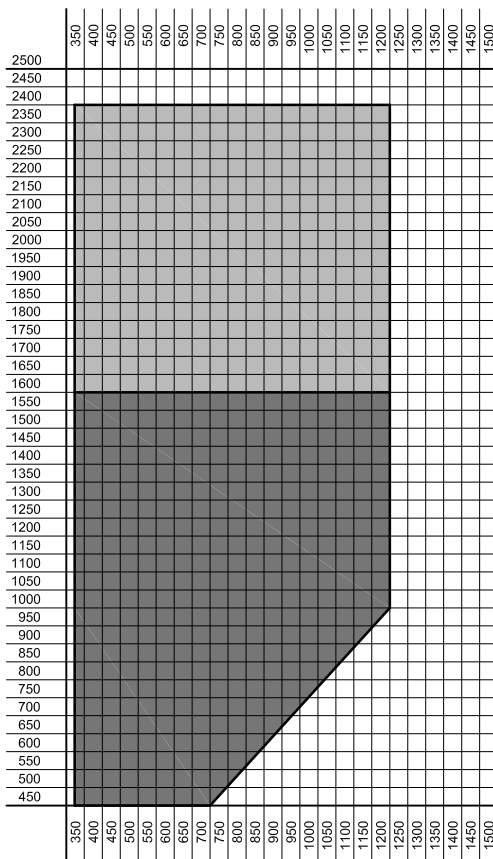

P 815240

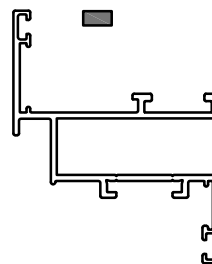

P 815250

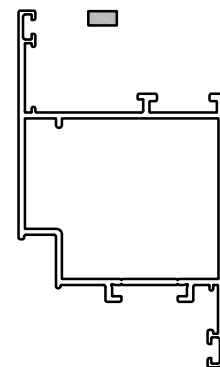

FB [sash width] must not exceed 125% of FH [sash height]

For additional locks see the following fitting variants

2100	100%	100%	100%	100%	100%	100%	100%	100%	100%	100%
2000	100%	100%	100%	100%	100%	100%	100%	100%	100%	100%
1900	100%	100%	100%	100%	100%	100%	100%	100%	100%	100%
1800	100%	100%	100%	100%	100%	100%	100%	100%	100%	100%
1700	100%	100%	100%	100%	100%	100%	100%	100%	100%	100%
1600	100%	100%	100%	100%	100%	100%	100%	100%	100%	100%
1500	100%	100%	100%	100%	100%	100%	100%	100%	100%	100%
1400	100%	100%	100%	100%	100%	100%	100%	100%	100%	100%
1300	100%	100%	100%	100%	100%	100%	100%	100%	100%	95%
1200	100%	100%	100%	100%	100%	100%	100%	100%	100%	90%
1100	100%	100%	100%	100%	100%	100%	100%	100%	90%	75%
1000	100%	100%	100%	100%	100%	100%	100%	90%	75%	60%
900	100%	100%	100%	100%	100%	100%	90%	75%	60%	45%
800	100%	100%	100%	100%	100%	90%	75%	60%	45%	25%
700	100%	100%	100%	100%	90%	75%	60%	45%	X	X
600	100%	100%	100%	90%	75%	60%	45%	X	X	X
450	100%	100%	90%	75%	60%	X	X	X	X	X
H \ L	370	400	500	600	700	800	900	1000	1100	1200

Example: 80% x 80kg= 64Kg

### Solution B

- Z 997253 max. weight 80 kg
- Z 997247 max. weight 100 kg
- Z 997417 max. weight 120 kg
- Z 997418 max. weight 80 kg

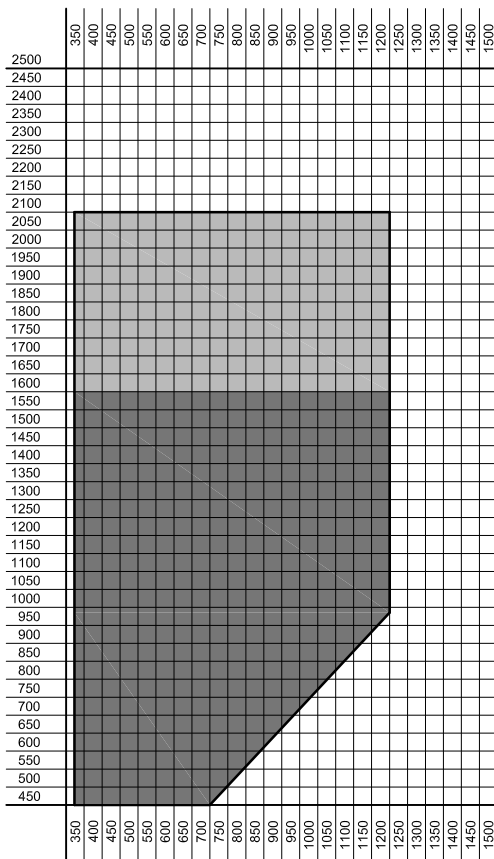

113001300

P 815240

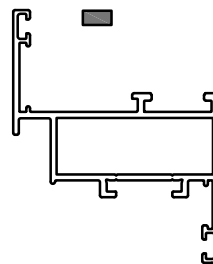

P 815250

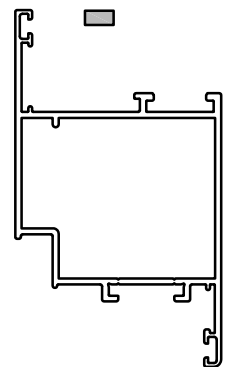

FB [sash width] must not exceed 125% of FH [sash height]

For additional locks see the following fitting variants

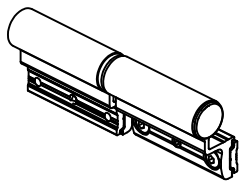

① **Z 997425**

adjustable door hinges with threaded plate - two wings - load 120 kg  
Packing unit (1x)

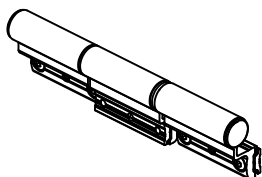

② **Z 997426**

adjustable door hinges with threaded plate - three wings - load 160 kg  
Packing unit (1x)

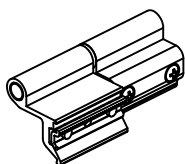

③ **Z 997253**

Fast mounting hinge (2 parts) - load 80 kg  
Packing unit (2x)

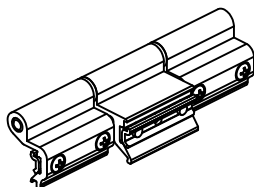

④ **Z 997247**

Fast mounting hinge (3 parts) - load 100 kg  
Packing unit (2x)

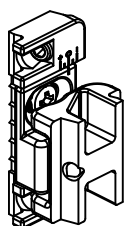

⑤ **Z 997424**

Additional intermediate third closing point

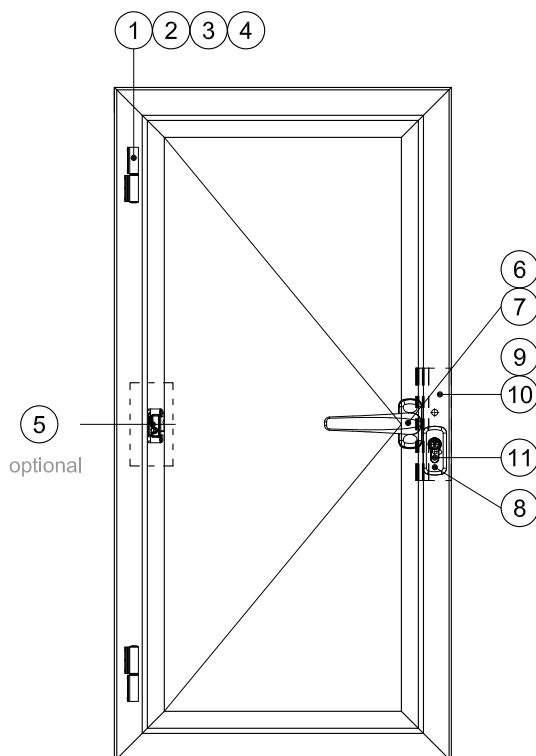

Installation: refer to processing information

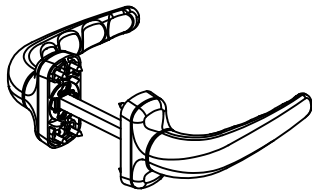

⑥ Z 997254

Comfort double handle

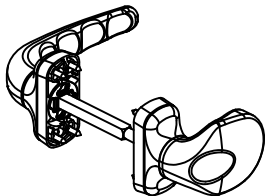

⑦ Z 997427

Fixed knob with comfort handle

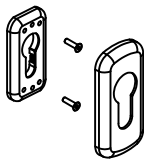

⑧ Z 997255

Cylinder cover for shaped cylinder

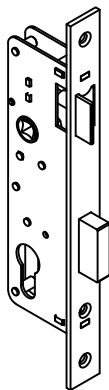

⑨ Z 918402

Mortise lock with catch and stainless steel front plate, 35 mm backset, single-turn, (with change-over), 8 mm spindle hole, designated for profile cylinder, suitable for left and right due to reversible latch bolt



⑩ Z 918504

Strike plate, plastic

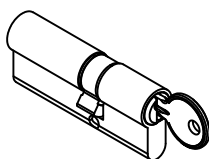

⑪ Z 918403

Profile cylinder  
5 spine dual function

115001500

Installation: refer to processing information

		B								C		
H	B	2600	100%	100%	100%	100%	100%	100%	100%	100%	100%	C
		2500	100%	100%	100%	100%	100%	100%	100%	100%	100%	
		2400	100%	100%	100%	100%	100%	100%	100%	100%	85%	
	A	2300	100%	100%	100%	100%	100%	100%	100%	100%	77%	D
		2200	100%	100%	100%	100%	100%	100%	100%	83%	69%	
		2100	100%	100%	100%	100%	100%	100%	100%	75%	62%	
		2000	100%	100%	100%	100%	100%	100%	82%	67%	54%	
		1900	100%	100%	100%	100%	100%	100%	73%	58%	50%	
		1800	100%	100%	100%	100%	100%	80%	64%	50%	50%	
		1700	100%	100%	100%	100%	100%	70%	55%	50%	50%	
		1600	100%	100%	100%	78%	60%	50%	50%	50%	50%	
		600	700	800	900	1000	1100	1200	1300			
		A								D		
		L										

Calculate the sash load capacity in percentage as indicated in the table (according to the dimensions)  
 Example Z 997425 - Sash L1200xH2100:120Kg (100%) x 75/100= 90Kg (A)

### Load capacity

(2 Part)	120Kg	160Kg
Z 997425	100%	
(3 Part)	120Kg	160Kg
Z 997426		100%

### Hinges

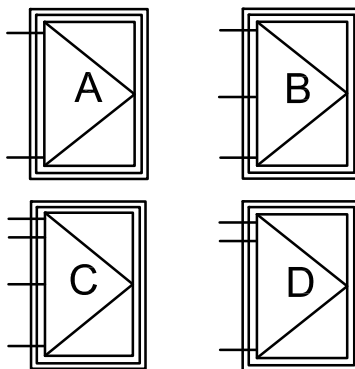



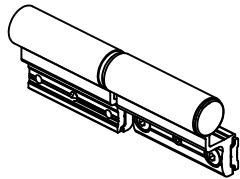

① Z 997425

adjustable door hinges with threaded plate - two wings - load 120 kg  
Packing unit (1x)

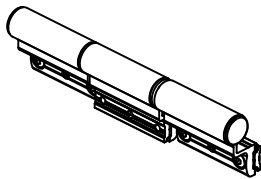

② Z 997426

adjustable door hinges with threaded plate - three wings - load 160 kg  
Packing unit (1x)

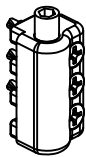

③ Z 923021

vertikal hinge regulator

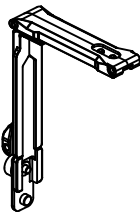

④ Z 918508

corner drive with counterplate

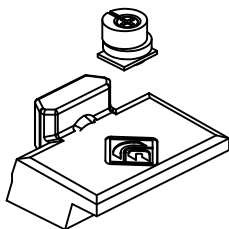

⑤ Z 918507

Fittings accessories  
Extra locking pin

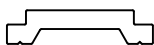

⑥ K 910137

Polyamid rod  
Coil from 250 m

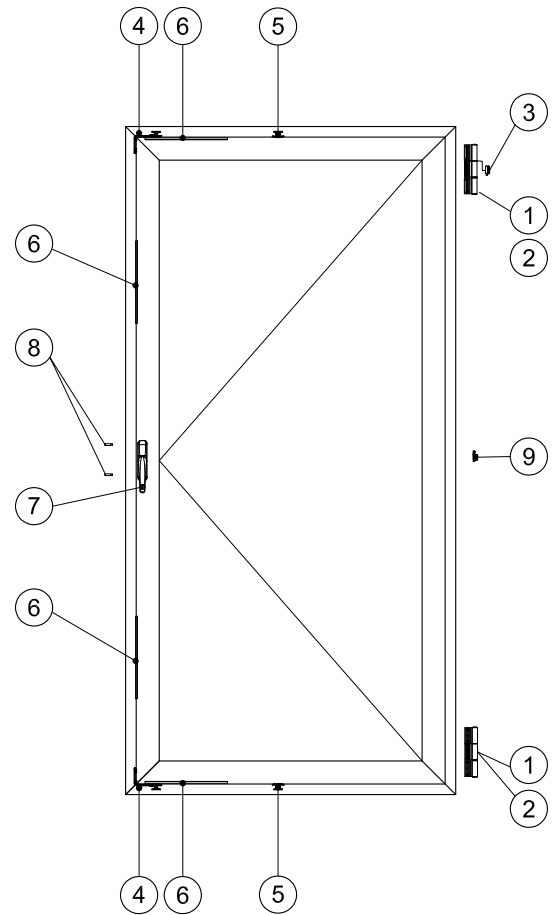

117000100

Installation: refer to processing information

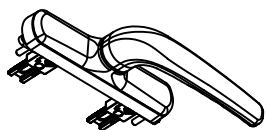

- ⑦ Z 923022  
adjustable cremone for outward opening

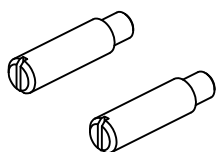

- ⑧ Z 923023  
connecting pin

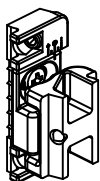

- ⑨ Z 997424  
Additional closing point

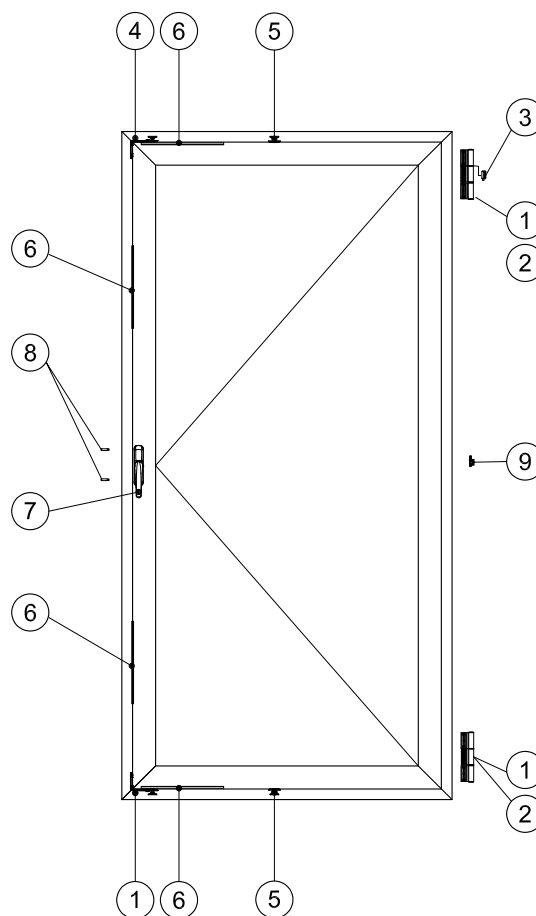

Installation: refer to processing information

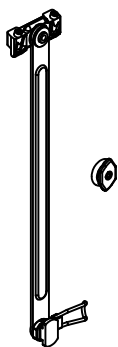

① Z 997249

limiter for top hung opening  
window-long version  
height from 600 mm to 1200 mm,  
max. load 70 kg  
Packing unit (2x)

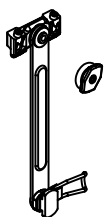

① Z 997313

limiter for top hung opening  
window-short version  
height from 260 mm to 800 mm,  
max. load 70 kg  
Packing unit (2x)



② Z 997251

Ring nylon catch



② Z 997428

Ring zamak catch

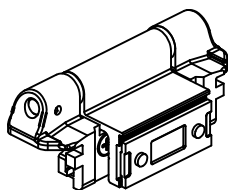

③ Z 997417

Comb hinge - Load 120 kg  
Packing unit (1x)

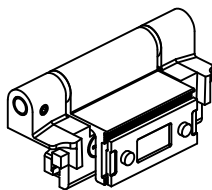

③ Z 997418

Comb hinge - Load 80 kg  
Packing unit (1x)

### Solution A

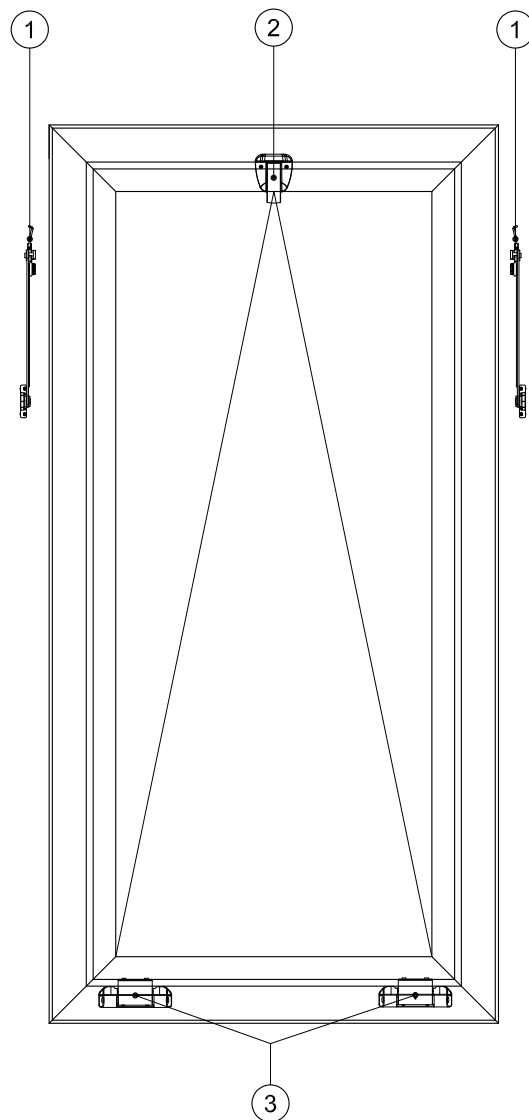

119001700

Installation: refer to processing information

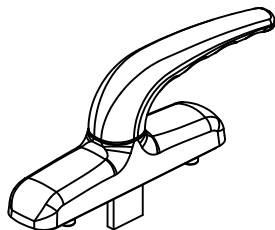

- ① **Z 997429**  
limiter for top hung opening  
window-long version  
height from 600 mm to 1600 mm,  
max. load 70 kg

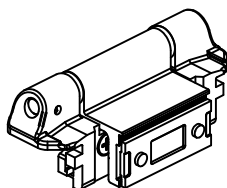

- ② **Z 997417**  
Comb Hinge - Load 120 kg  
Packing unit (1x)

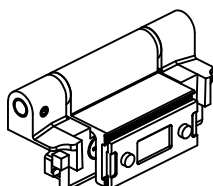

- ② **Z 997418**  
Comb Hinge - Load 80 kg  
Packing unit (1x)

### Solution B

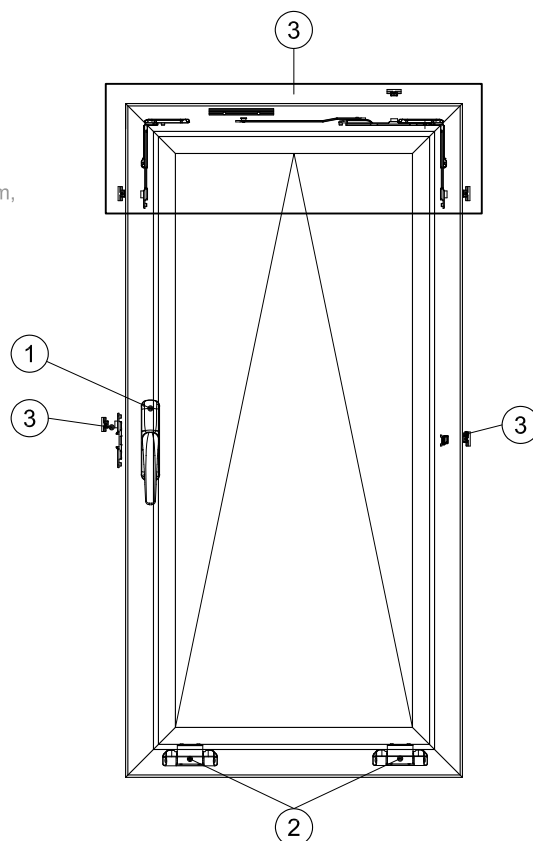

### Solution C (for bigger sash dimension)

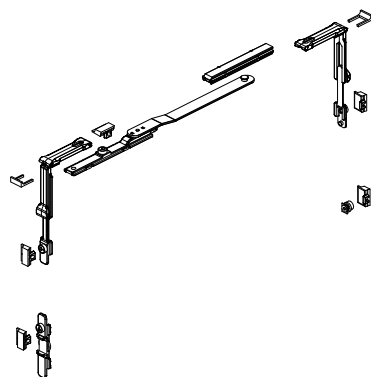
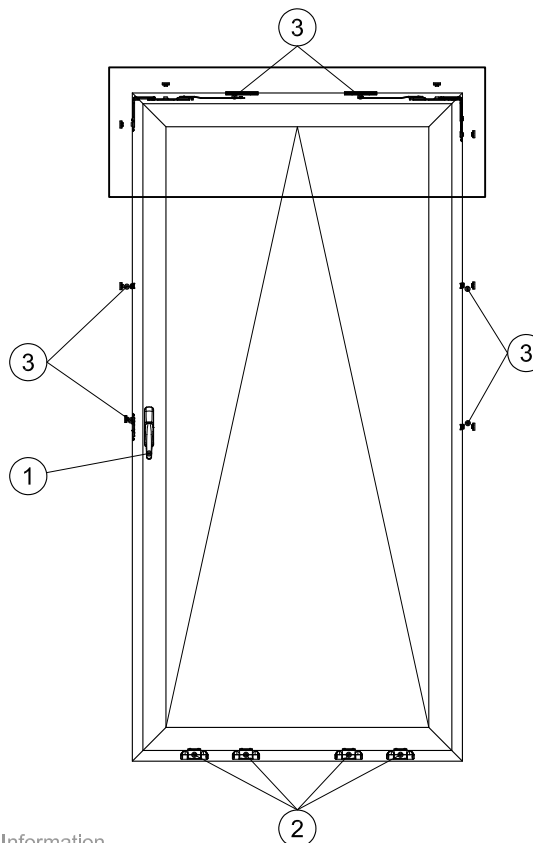

- ③ **Z 997248**  
Kits for bottom hinge opening  
inside (Solution B)

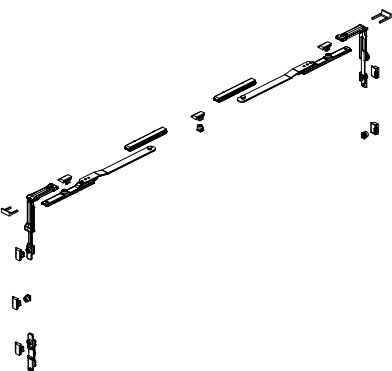

- ③ **Z 997431**  
Kits for bottom hinge opening  
inside (Solution C)

Installation: refer to Processing Information

120001800

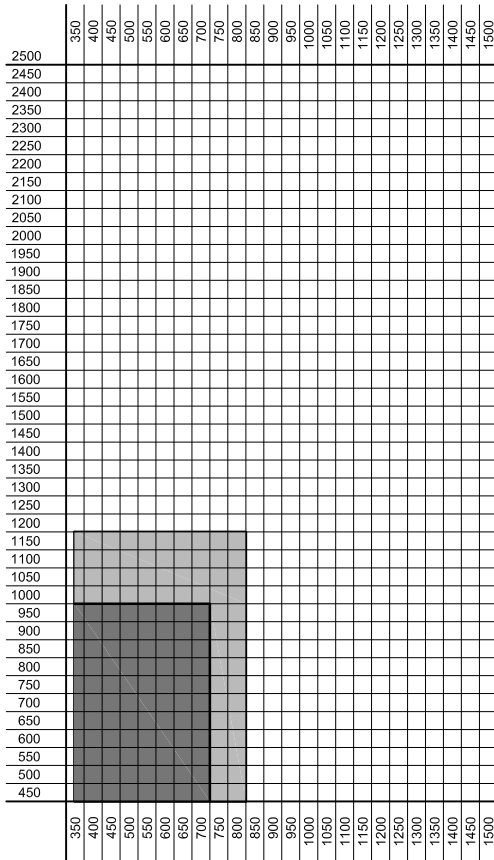

**Solution A**  
max. weight 70 kg

**P 815240**

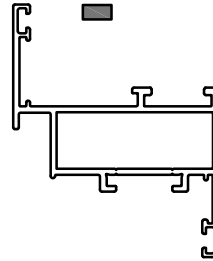

**P 815250**

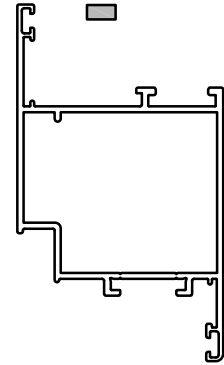

FB [sash width] must not exceed 125% of FH [sash height]

For additional locks see the following fitting variants

**Solution B** max. weight 80 / 120 kg

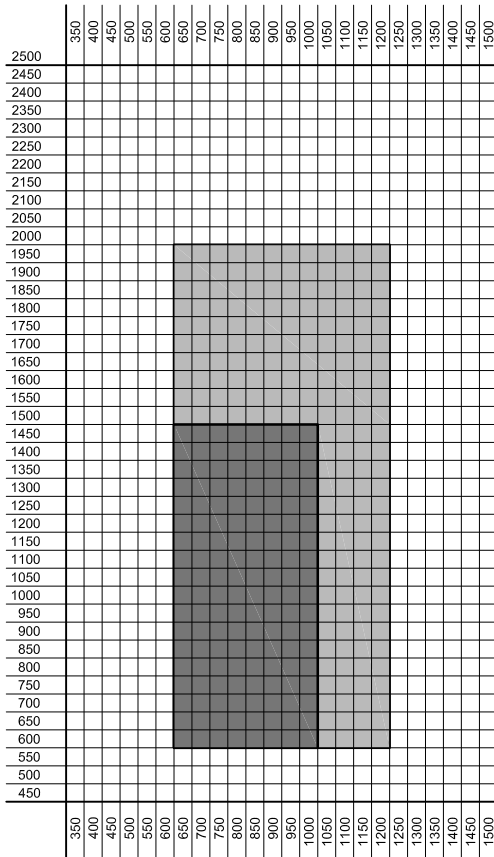

**Solution C** max. weight 80 / 120 kg

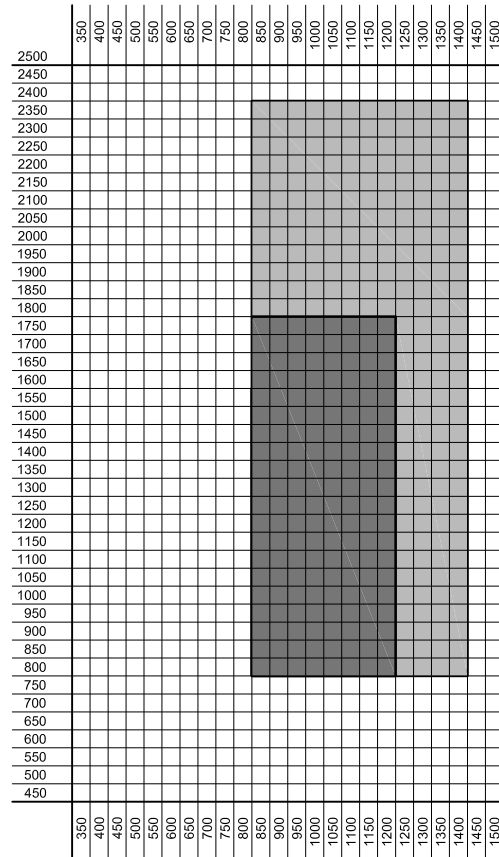

121001900



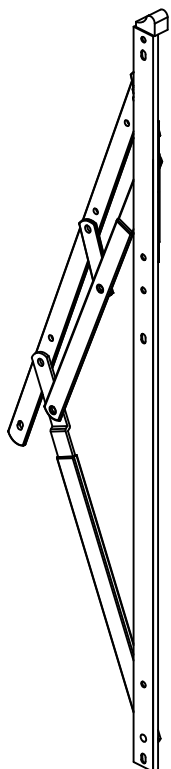

①

Art. no.	Size	Opening angle max.	Sash weight max.
<b>Z 997435</b>	10	35° - 45°	50 kg
<b>Z 997436</b>	12	35° - 40°	70 kg
<b>Z 997437</b>	14	30° - 40°	80 kg
<b>Z 997438</b>	16	25° - 35°	95 kg
<b>Z 997439</b>	18	25° - 35°	108 kg

Stay hinge  
Packing unit (Left + right)

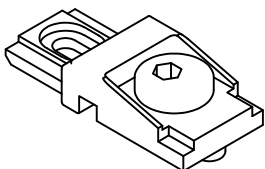

②

**Z 914455**

Fittings accessories  
top hung projecting out window  
Packing unit (2x)

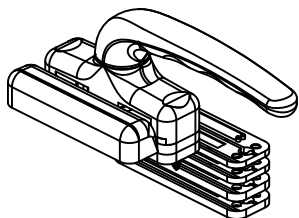

③

**Z 997445**

Lever handle

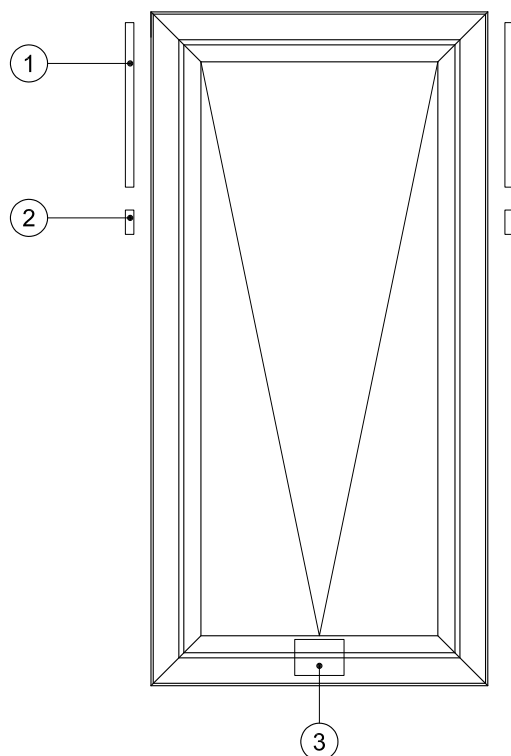

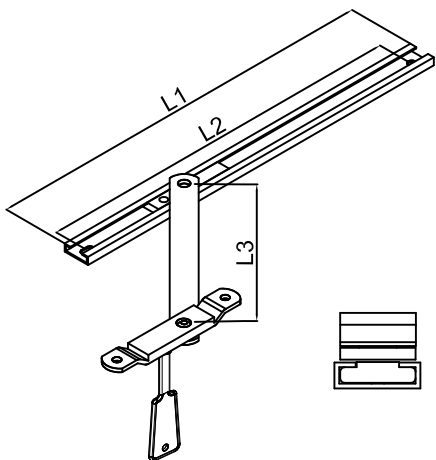

Art. no.	L (inch)	L1	L2	L3
<b>Z 997446</b>	6	150,5	131	85
<b>Z 997447</b>	8	201	184	152
<b>Z 997448</b>	10	254	236	180

Friction limiter arm with unlock key  
Packing unit (2x)

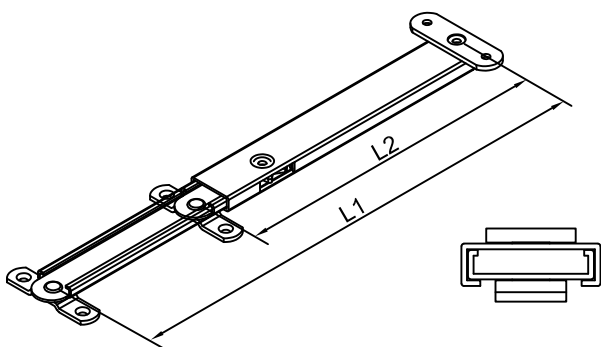

Art. no.	L (inch)	L1	L2
<b>Z 997449</b>	8	205	150
<b>Z 997450</b>	10	255	175
<b>Z 997451</b>	12	305	200

Telescopic limiter arm  
Packing unit (2x)



**Z 918611**

Unlock key

Installation: refer to Processing Information







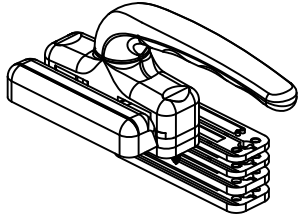

① Z 997445

Lever handle

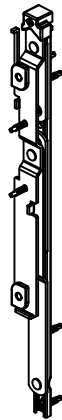

② Z 997454

Easy Rapid Stay hinges- Load:  
20 kg with L. 450x H.1200mm  
Packing unit left and right

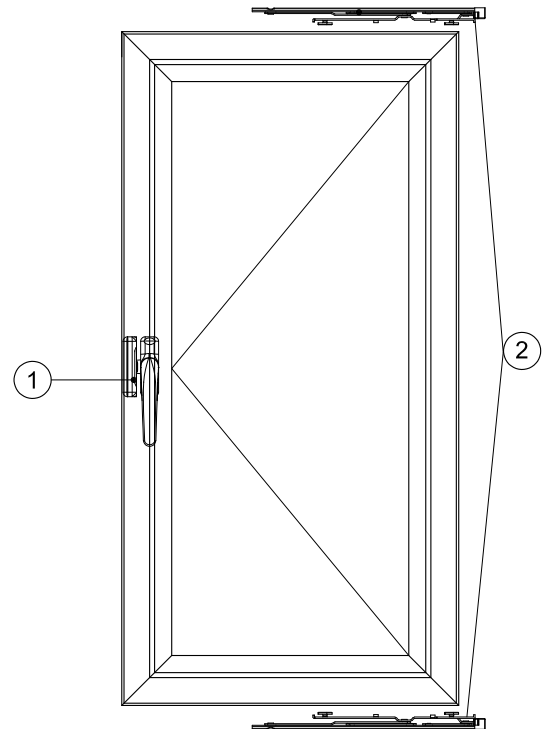



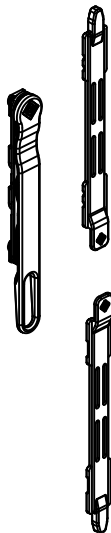
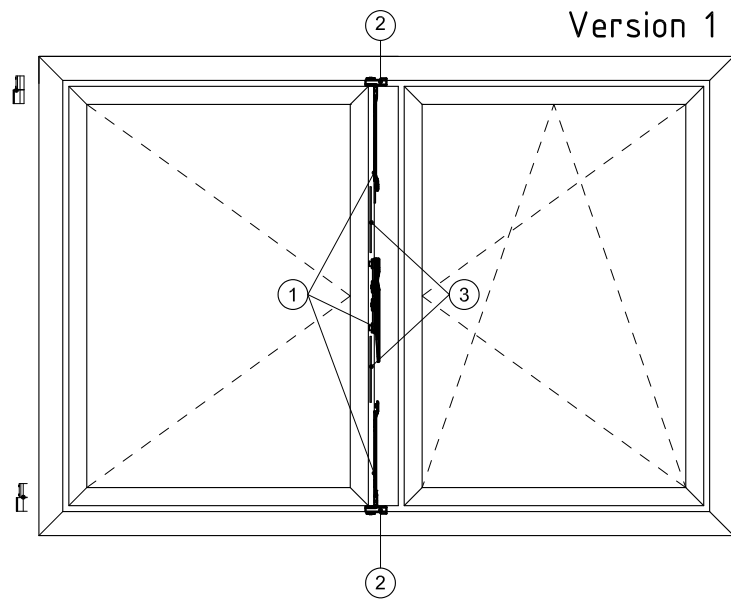

**Z 997614**

① Two way movement for passiv sash

compatible with  
1. sash hardware

Z 997412  
Z 997416  
Z 997421

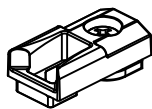

② **Z 918628**

one rod junction  
Packing unit (1x)

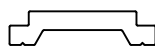

③ **K 910137**

Polyamid rod  
Coil from 250 m

129002700

Installation: refer to processing information

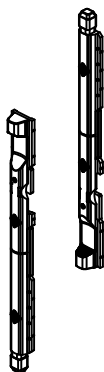
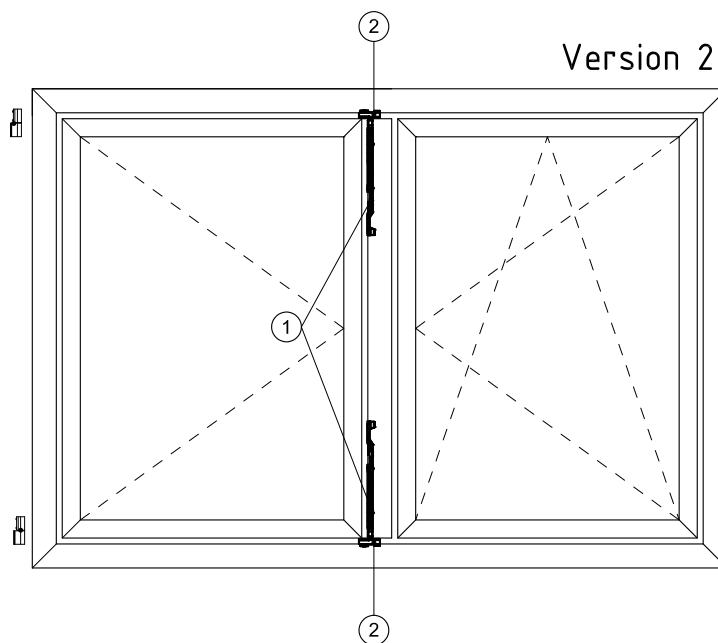

- ① **Z 997615**  
Direct driving latch  
Packing Unit (2x)

compatible with 1. sash hardware
<b>Z 997421</b>

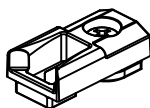

- ② **Z 918628**  
one rod junction  
Packing Unit (1x)

Installation: refer to processing information

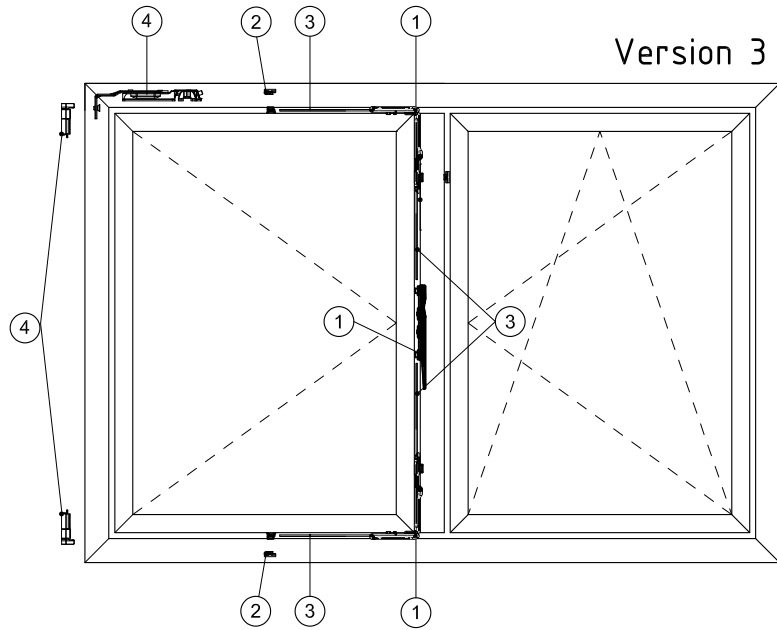

① Z 997626

Two way movement for passiv sash with transmission corner with counterplate

compatible with  
1. sash hardware

Z 997421

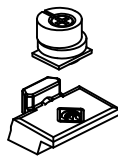

② Z 918507

extra locking pin

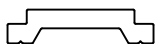

③ K 910137

Polyamid rod  
Coil from 250 m

131002900

Installation: refer to processing information

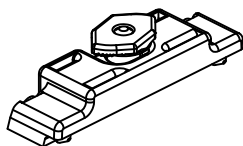

**Z 997423**

Sash stopper

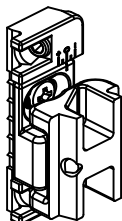

**Z 997424**

HOOK Additional intermediate third closing point

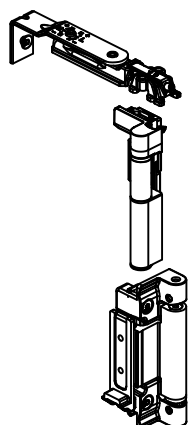

**Z 997422**

Kit for secondary sash

**Solution A**

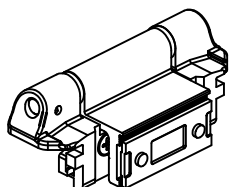

**Z 997417**

Comb Hinge - Load 120 kg  
Packing Unit (1x)

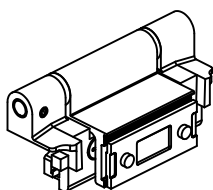

**Z 997418**

Comb Hinge - Load 80 kg  
Packing Unit (1x)

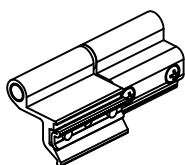

**Z 997253**

Fast mounting hinge (2 parts) -  
load 80 kg  
Packing unit (2x)

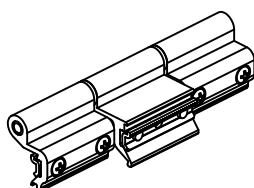

**Z 997247**

Fast mounting hinge (3 parts) -  
load 100 kg  
Packing unit (2x)

Installation: refer to processing information

**Solution B**



2400	100%	100%	100%	100%	100%	100%	100%	100%	100%	100%
2300	100%	100%	100%	100%	100%	100%	100%	100%	100%	100%
2200	100%	100%	100%	100%	100%	100%	100%	100%	100%	100%
2100	100%	100%	100%	100%	100%	100%	100%	100%	100%	100%
2000	100%	100%	100%	100%	100%	100%	100%	100%	100%	100%
1900	100%	100%	100%	100%	100%	100%	100%	100%	100%	98%
1800	100%	100%	100%	100%	100%	100%	100%	100%	100%	90%
1700	100%	100%	100%	100%	100%	100%	100%	100%	95%	82%
1600	100%	100%	100%	100%	100%	100%	100%	100%	85%	73%
1500	100%	100%	100%	100%	100%	100%	100%	90%	76%	65%
1400	100%	100%	100%	100%	100%	100%	96%	80%	67%	57%
1300	100%	100%	100%	100%	100%	100%	84%	70%	58%	X
1200	100%	100%	100%	100%	100%	100%	90%	73%	60%	X
1100	100%	100%	100%	100%	100%	97%	78%	62%	50%	X
1000	100%	100%	100%	100%	100%	83%	65%	51%	X	X
$\frac{H}{L}$	370	400	500	600	700	800	900	1000	1100	1200

sash weight Example: 80% x 130kg= 104Kg

x Not feasible

### Solution A

Z 997422 max. weight 130 kg

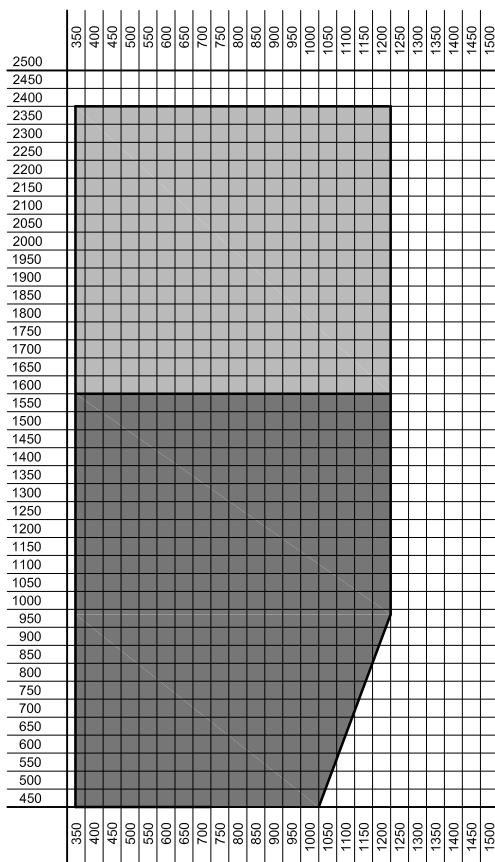

133003100

P 815240  
+ P 815225

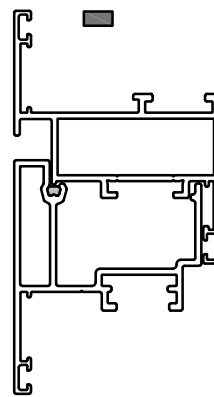

P 815250  
+ P 815225

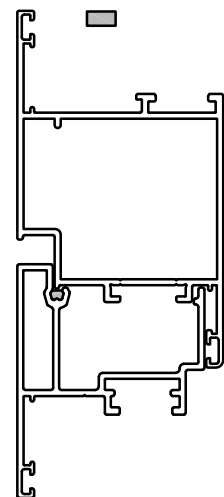

P 815220

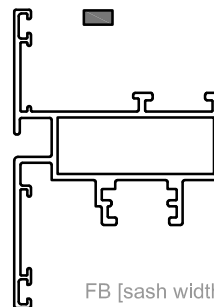

FB [sash width] must not exceed 125% of FH [sash height]

For additional locks see the following fitting variants

2100	100%	100%	100%	100%	100%	100%	100%	100%	100%	100%
2000	100%	100%	100%	100%	100%	100%	100%	100%	100%	100%
1900	100%	100%	100%	100%	100%	100%	100%	100%	100%	98%
1800	100%	100%	100%	100%	100%	100%	100%	100%	100%	90%
1700	100%	100%	100%	100%	100%	100%	100%	100%	95%	82%
1600	100%	100%	100%	100%	100%	100%	100%	100%	85%	73%
1500	100%	100%	100%	100%	100%	100%	100%	90%	76%	65%
1400	100%	100%	100%	100%	100%	100%	96%	80%	67%	57%
1300	100%	100%	100%	100%	100%	100%	84%	70%	58%	X
1200	100%	100%	100%	100%	100%	90%	73%	60%	X	X
1100	100%	100%	100%	100%	97%	78%	62%	50%	X	X
1000	100%	100%	100%	100%	83%	65%	51%	X	X	X
$\frac{H}{L}$	370	400	500	600	700	800	900	1000	1100	1200

sash weight example: 80% x 80 kg= 64Kg

x Not feasible

### Solution B

- Z 997253 max. weight 80 kg
- Z 997247 max. weight 100 kg
- Z 997417 max. weight 120 kg
- Z 997418 max. weight 80 kg

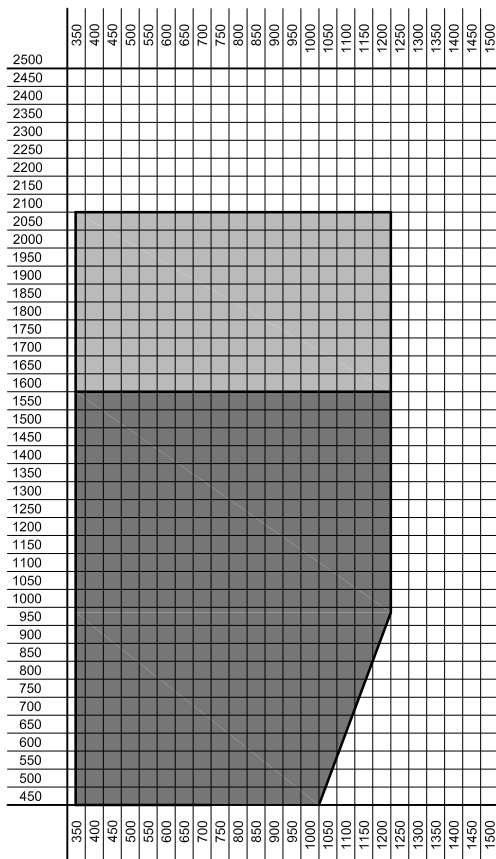

P 815240  
+ P 815225

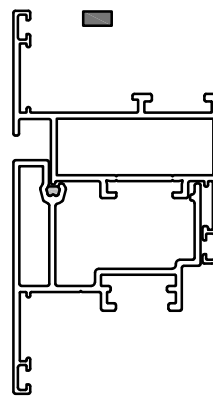

P 815250  
+ P 815225

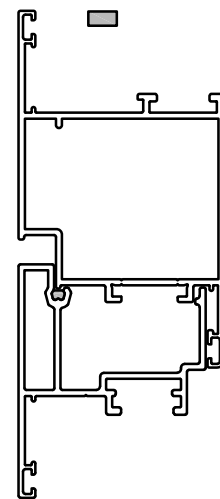

P 815220

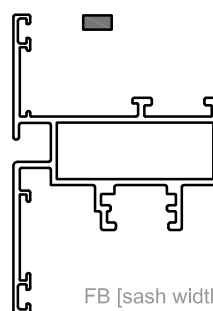

FB [sash width] must not exceed 125% of FH [sash height]

For additional locks see the following fitting variants

## A-A

Gv1, Gv2 = see glass dimensions

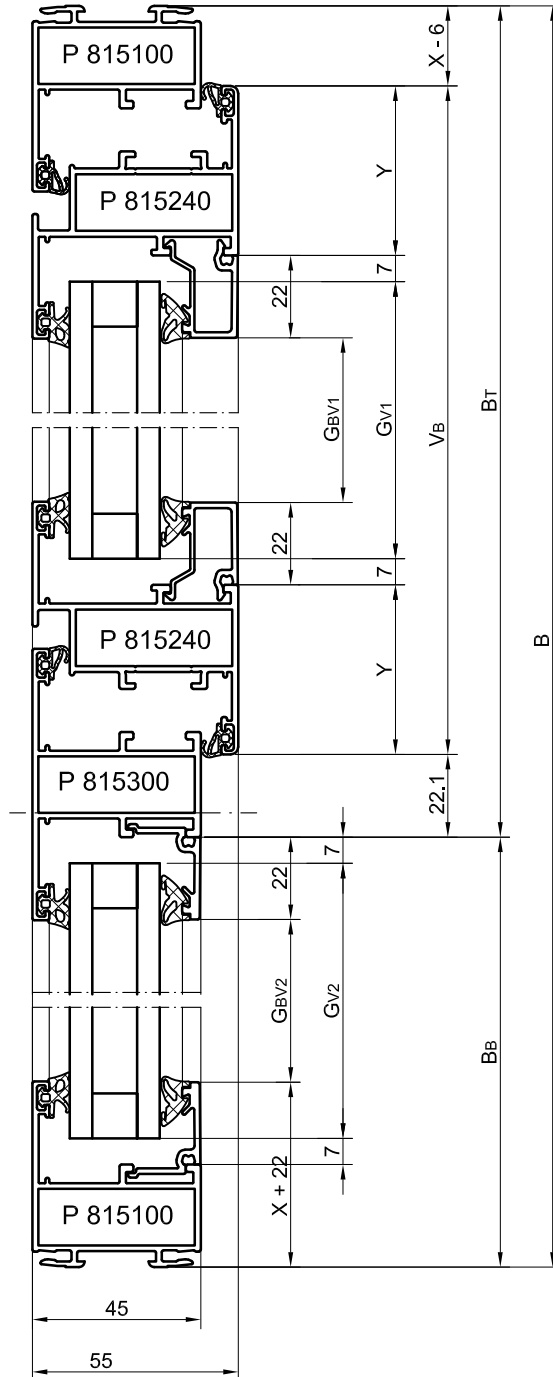

151000100

## B-B

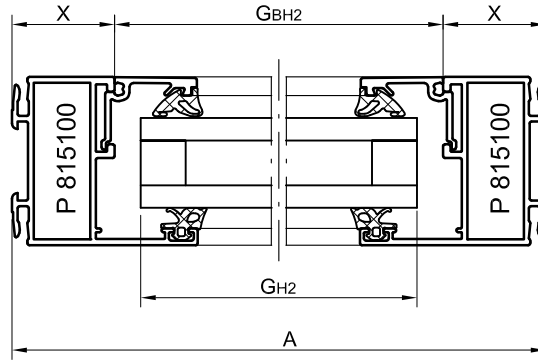

## C-C

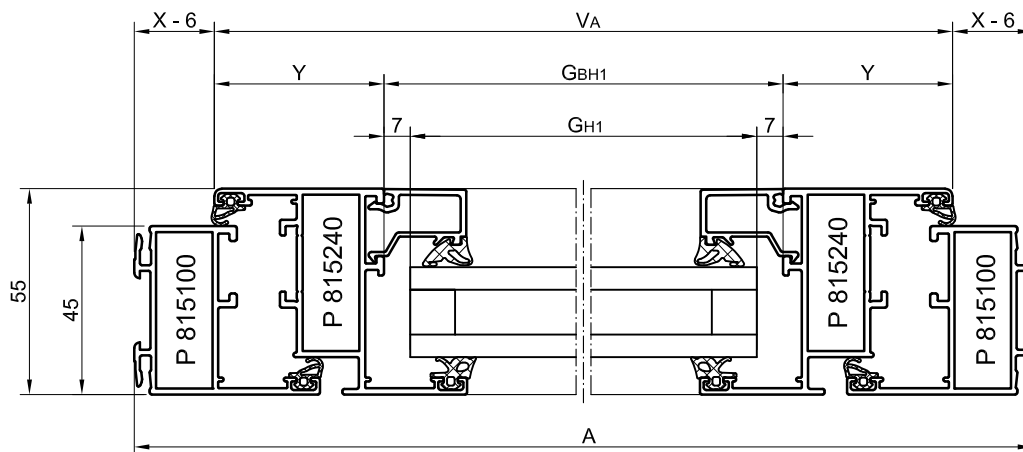

GH1, GH2 = see glass dimensions

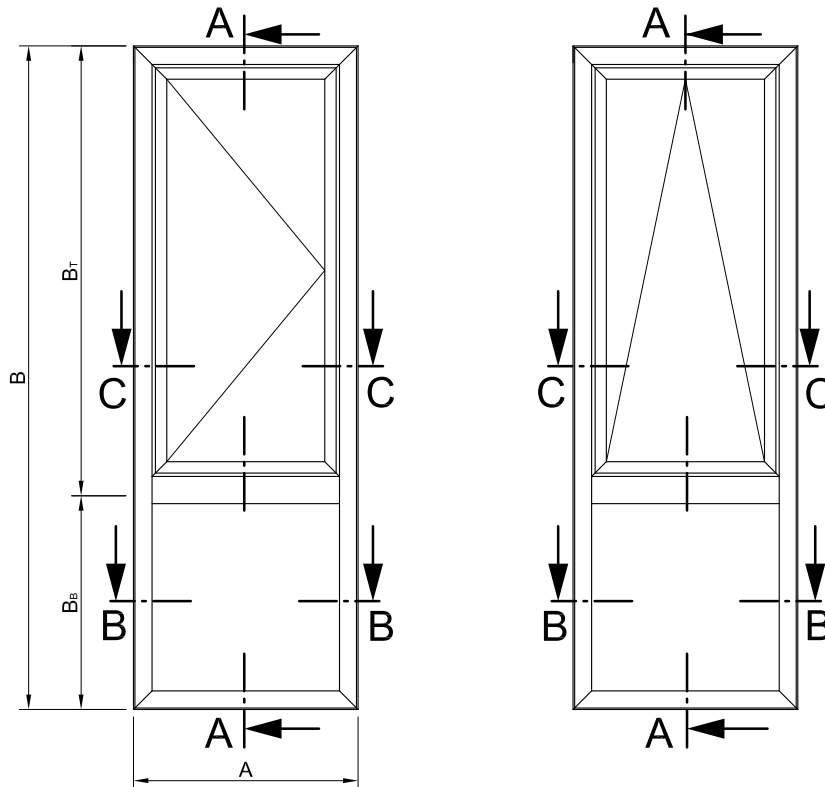

Description	Part no.	X
Frame 49,6	P 815100	27,4
Frame 65,3	P 815104	43,1
Frame 50,3	P 815111	28,1
Frame 66,0	P 815112	43,8

Description	Part no.	Y
Vent 67,5	P 815240	45,3
Vent 95,3	P 815250	73,1

Description	Part no.	Calculation	Number	Cut
frame horizontal	see profile table	$A = \text{horizontal element dimension}$	2x	
frame vertical	see profile table	$B = \text{vertical element dimension}$ $B_B = \text{vertical position of the Transom}$ $B_T = B - B_B$	2x	
transom	P 815300	$T = A - (2 * X)$	1x	
vent horizontal	P 815240 P 815250	$V_A = A - (2 * X) + 12$	2x	
vent vertical	P 815240 P 815250	$V_B = B_T - X - 16,1$	2x	
glazing bead horizontal (vent)	see glazing table	$GB_{H1} = V_A - (2 * Y)$	2x	
glazing bead vertical (vent)	see glazing table	$GB_{V1} = V_B - (2 * Y) - 44$	2x	
glazing bead horizontal (fix part)	see glazing table	$GB_{H2} = A - (2 * X)$	2x	
glazing bead vertical (fix part)	see glazing table	$GB_{V2} = B_B - X - 44$	2x	

153000300

## A-A

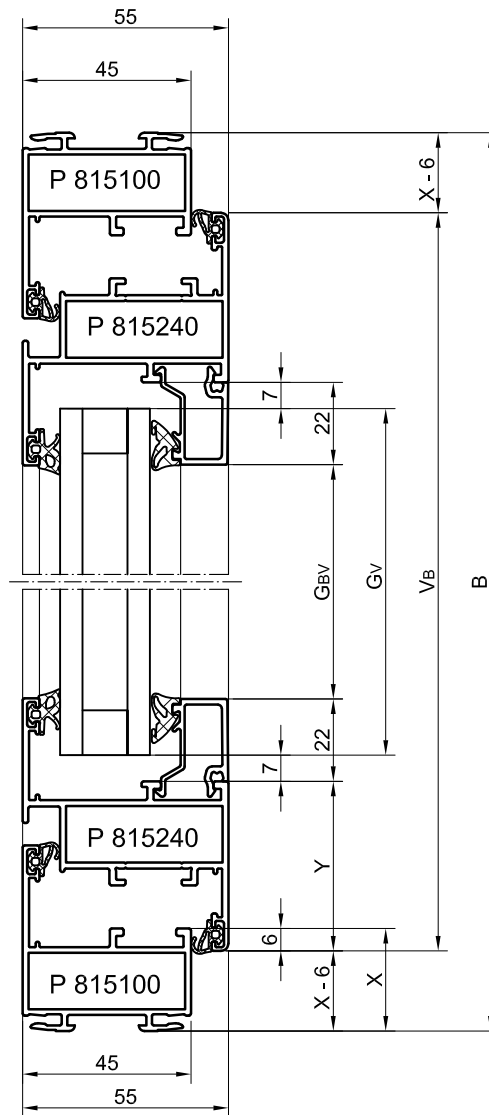

$GBH, GBV = \text{see glass dimensions}$

## B-B

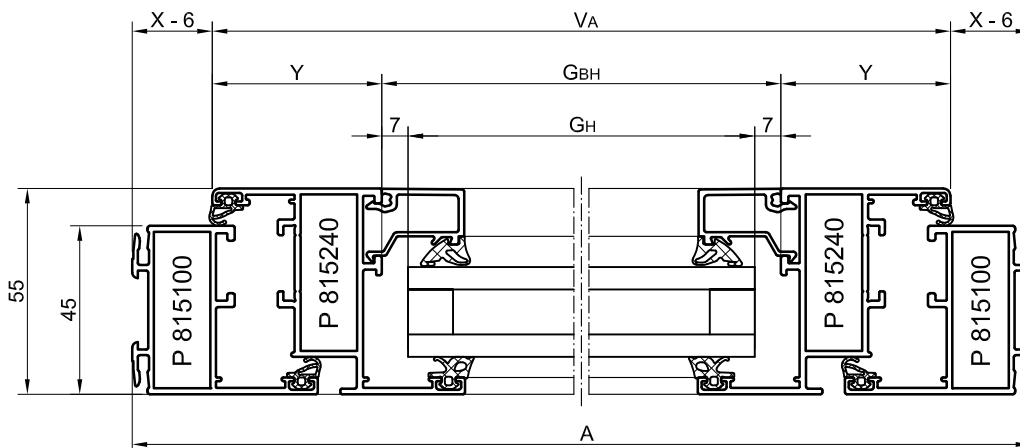

154000400

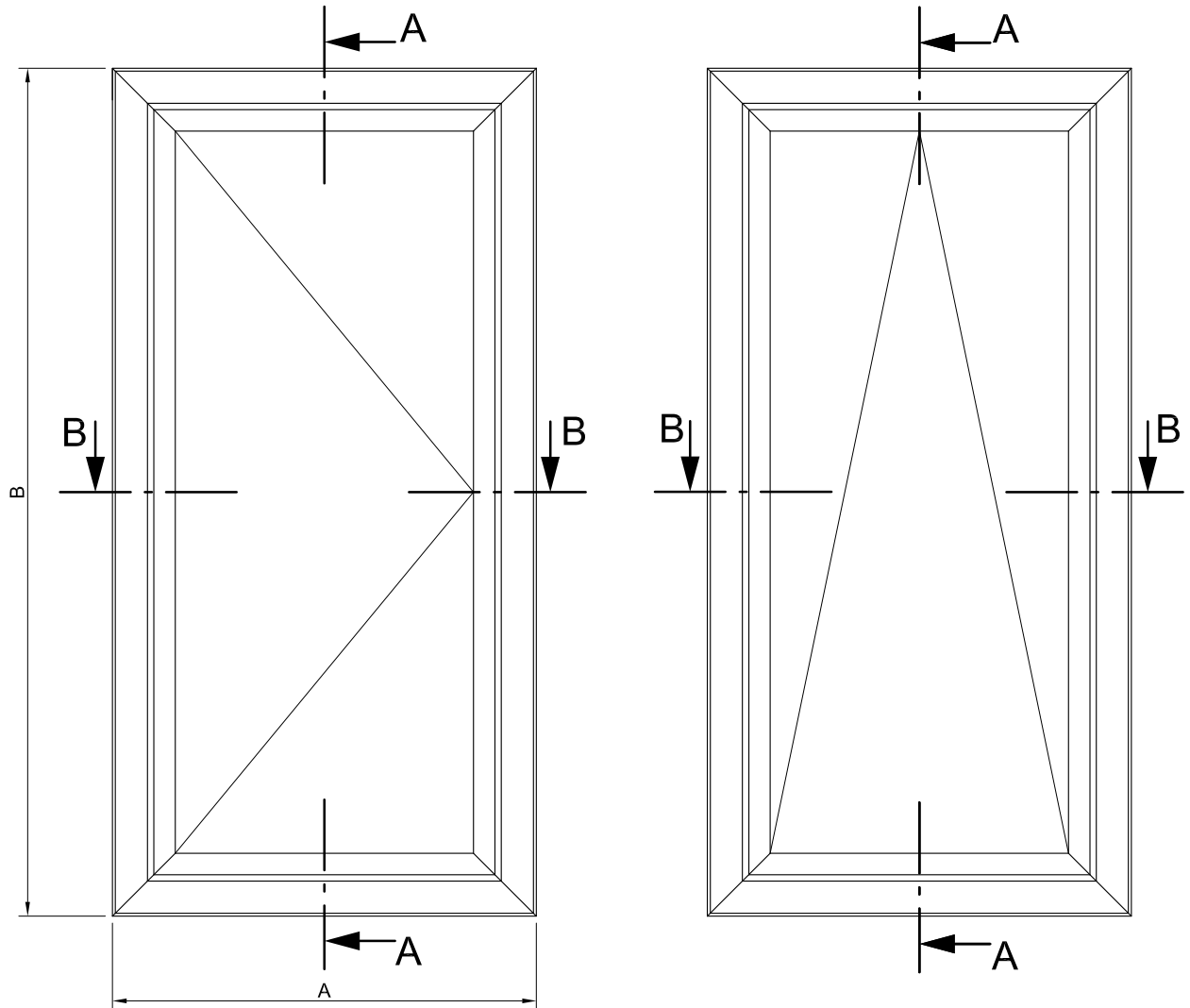

Description	Part no.	X
Frame 49,6	P 815100	27,4
Frame 65,3	P 815104	43,1
Frame 50,3	P 815111	28,1
Frame 66,0	P 815112	43,8

Description	Part no.	Y
Vent 67,5	P 815240	45,3
Vent 95,3	P 815250	73,1

Description	Part no.	Calculation	Number	Cut
frame horizontal	see profile table	A = horizontal element dimension	2x	
frame vertical	see profile table	B = vertical element dimension	2x	
vent horizontal	P 815240	$V_A = A - (2 * X) + 12$	2x	
	P 815250			
vent vertical	P 815240	$V_B = B - (2 * X) + 12$	2x	
	P 815250			
glazing bead horizontal	see glazing table	$GB_H = V_A - (2 * Y)$	2x	
glazing bead vertical	see glazing table	$GB_V = V_B - (2 * Y) - 44$	2x	

156006500

## A-A

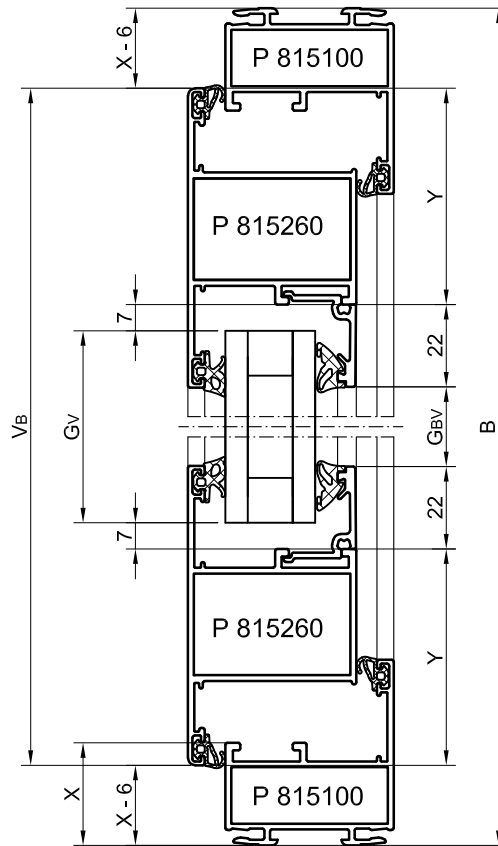

$G_v, G_H$  = see glass dimensions

## B-B

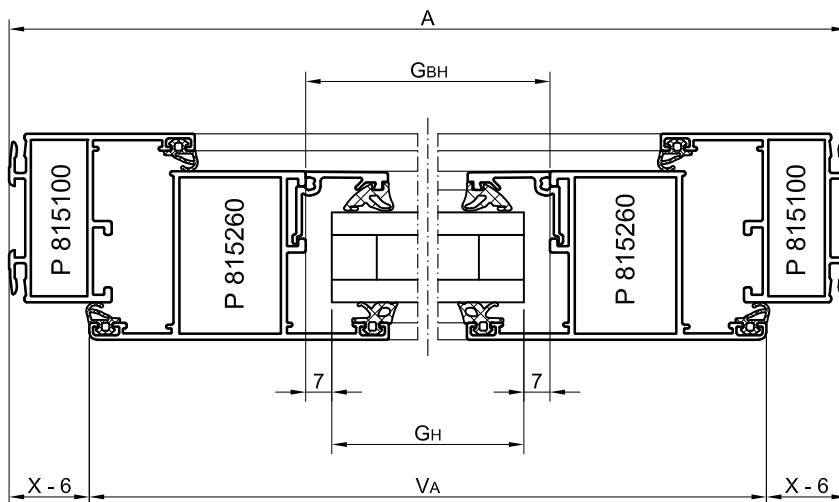

156000600



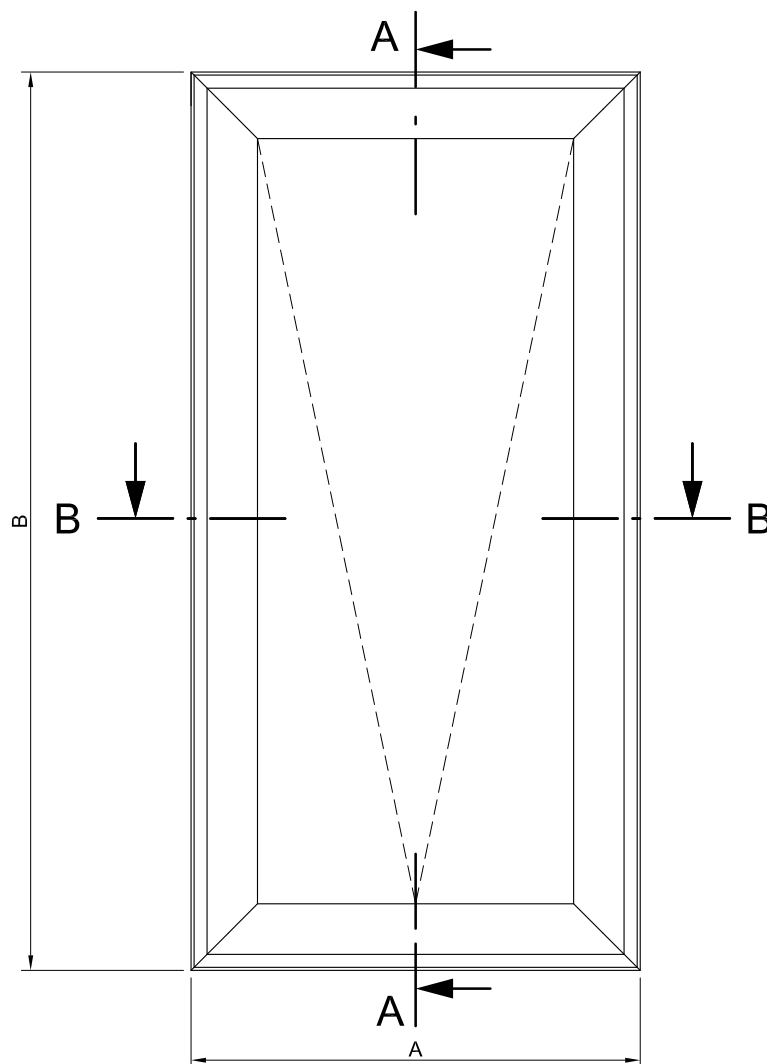

Description	Part no.	X
Frame 49,6	P 815100	27,4
Frame 65,3	P 815104	43,1
Frame 50,3	P 815111	28,1
Frame 66,0	P 815112	43,8

Description	Part no.	Y
Vent 80	P 815260	57,8
Vent 95,3	P 815270	73,1

Description	Part no.	Calculation	Number	Cut
frame horizontal	see profile table	$A = \text{horizontal element dimension}$	2x	
frame vertical	see profile table	$B = \text{vertical element dimension}$	2x	
vent horizontal	P 815260	$V_A = A - (2 * X) + 12$	2x	
	P 815270			
vent vertical	P 815260	$V_B = B - (2 * X) + 12$	2x	
	P 815270			
glazing bead horizontal	see glazing table	$GB_H = V_A - (2 * Y)$	2x	
glazing bead vertical	see glazing table	$GB_V = V_B - (2 * Y) - 44$	2x	

157000700

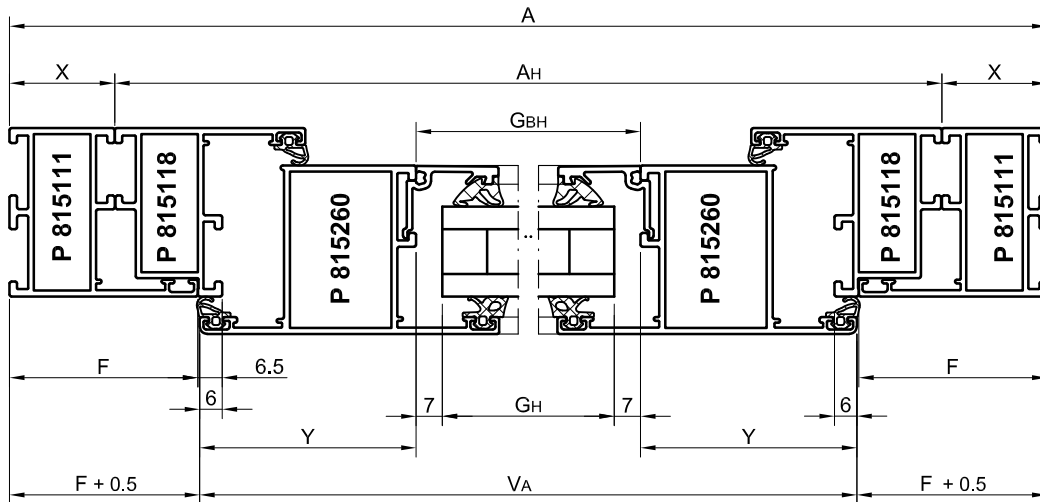
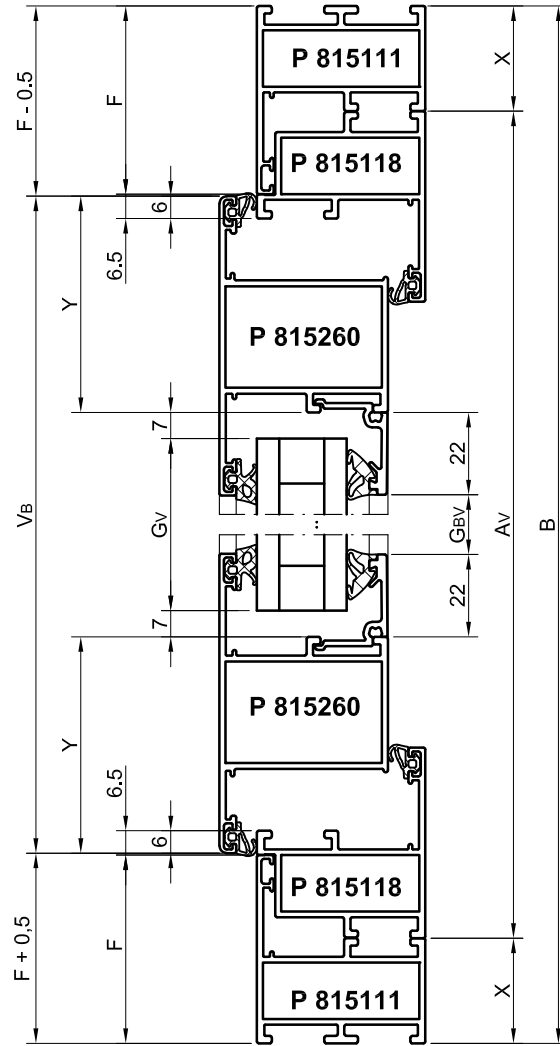

158000800

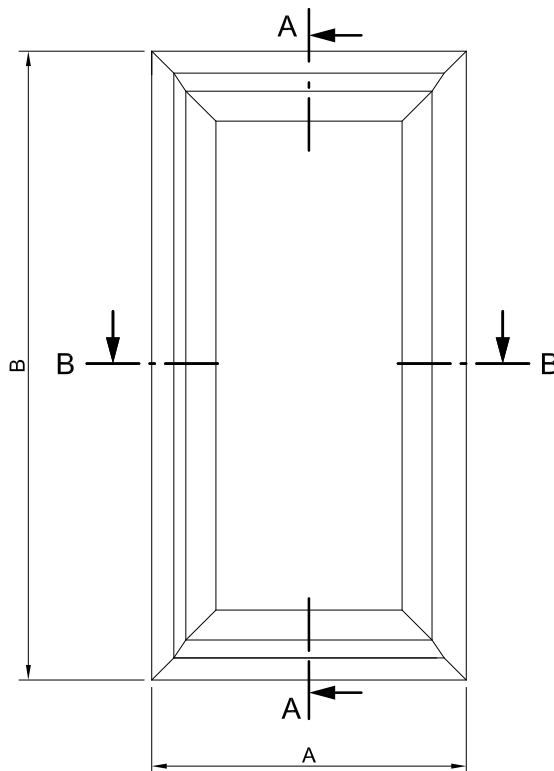

Description	Part no.	X
Frame F = 49,6	P 815100	27,4
Frame F = 65,3	P 815104	43,1
Frame F = 50,3	P 815111	28,1
Frame F = 66,0	P 815112	43,8

Description	Part no.	Y
Vent V = 80	P 815260	57,8
Vent V = 95,3	P 815270	73,1

Description	Part no.	Calculation	Number	Cut
frame horizontal	see profile table	A = horizontal element dimension	2x	
frame vertical	see profile table	B = vertical element dimension	2x	
adapter horizontal	P 815118	$A_H = A - (2 * X)$	2x	
adapter vertical	P 815118	$A_V = B - (2 * X)$	2x	
vent horizontal	P 815260	$V_A = A - (2 * F) - 1$	2x	
	P 815270			
vent vertical	P 815260	$V_B = B - (2 * F) - 1$	2x	
	P 815270			
glazing bead horizontal	see glazing table	$GB_H = V_A - (2 * Y)$	2x	
glazing bead vertical	see glazing table	$GB_V = V_B - (2 * Y) - 44$	2x	

159000900

### A-A

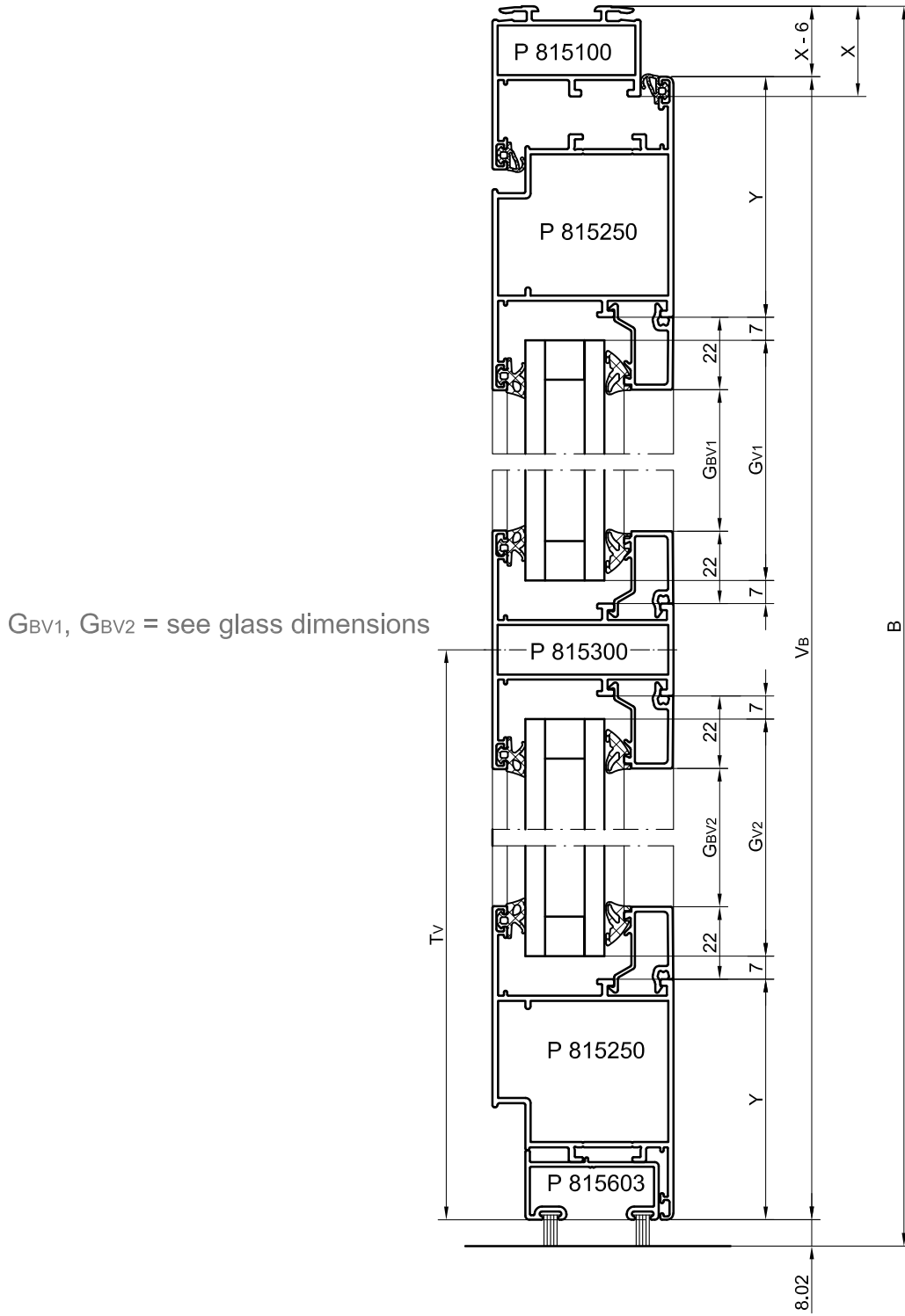

160000800

### B-B

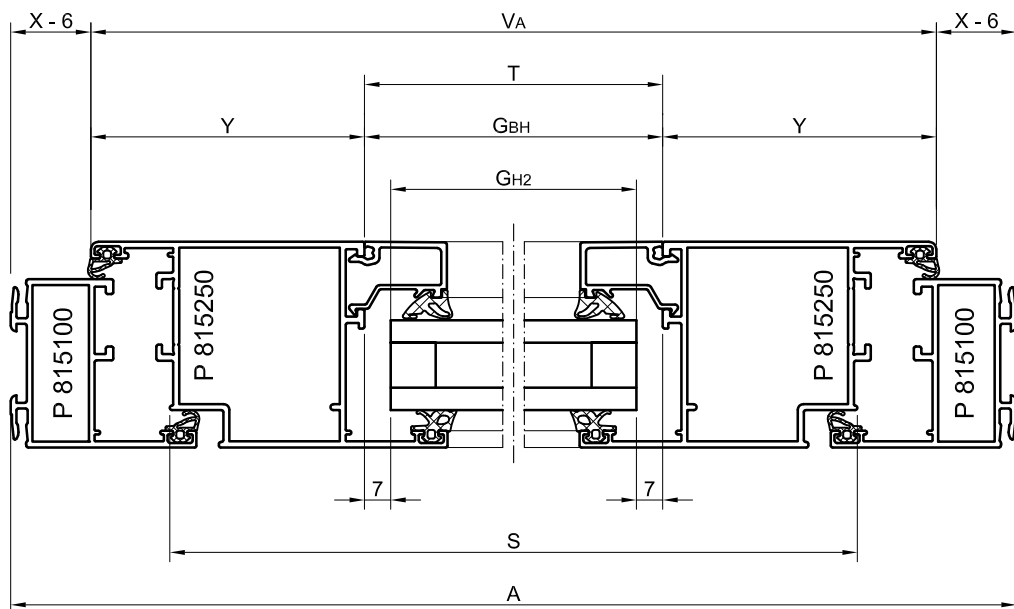

$GH2 = \text{see glass dimensions}$

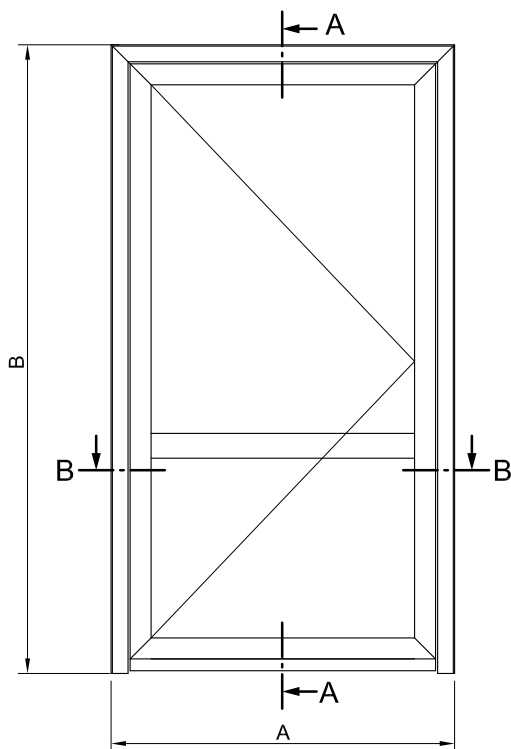

Description	Part no.	X
Frame 49,6	P 815100	27,4
Frame 65,3	P 815104	43,1
Frame 50,3	P 815111	28,1
Frame 66,0	P 815112	43,8

Description	Part no.	Y
Vent 67,5	P 815240	45,3
Vent 95,3	P 815250	73,1

Description	Part no.	Calculation	Number	Cut
frame horizontal	see profile table	$A = \text{horizontal element dimension}$	1x	
frame vertical	see profile table	$B = \text{vertical element dimension}$	2x	
vent horizontal	P 815240	$V_A = A - (2 * X) + 12$	2x	
	P 815250			
vent vertical	P 815240	$V_B = B - X - 2$	2x	
	P 815250			
transom	P 815301	$T = V_A - (2 * Y)$	1x	
supplementary door profile	P 815603	$S = V_A - 44$	1x	
glazing bead horizontal (top)	see glazing table	$GB_{H1} = V_A - (2 * Y)$	2x	
glazing bead vertical (top)	see glazing table	$GB_{V1} = V_B - T_V - Y - 58$	2x	
glazing bead horizontal (bottom)	see glazing table	$GB_{H2} = V_A - (2 * Y)$	2x	
glazing bead vertical (bottom)	see glazing table	$GB_{V2} = T_V - Y - 58$	2x	

162001000

## A-A

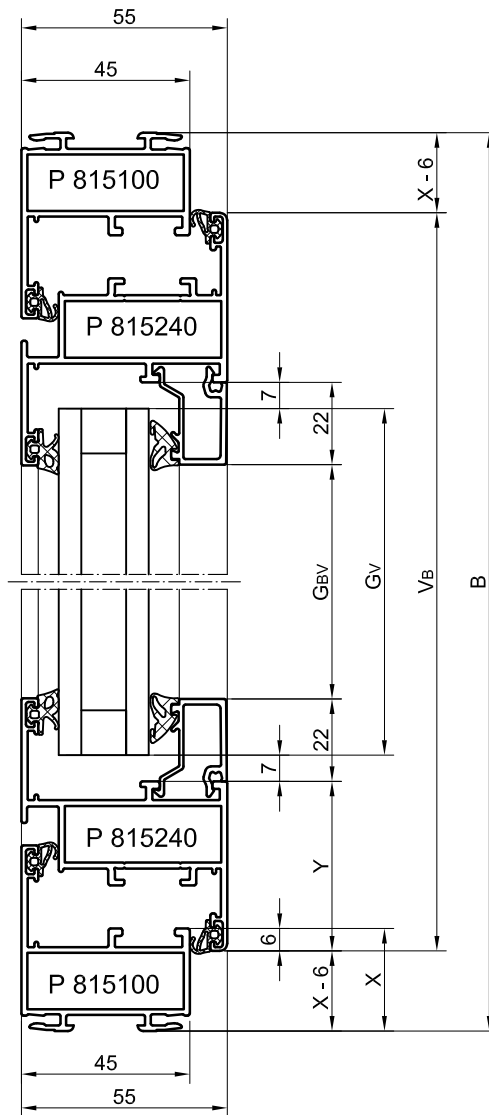

GBH, GBV = see glass dimensions

## B-B

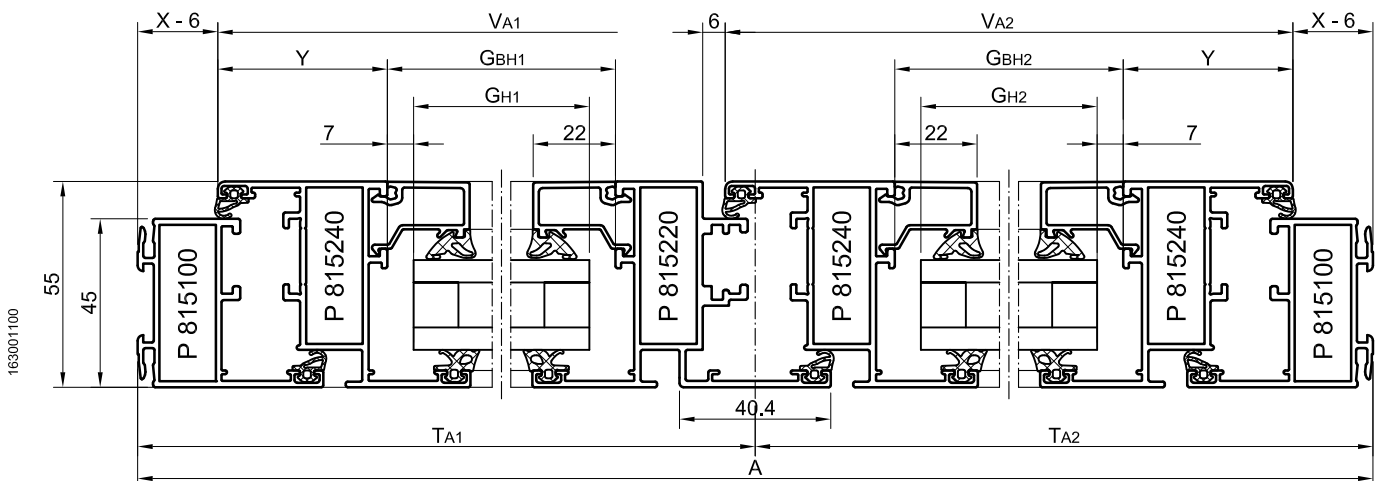

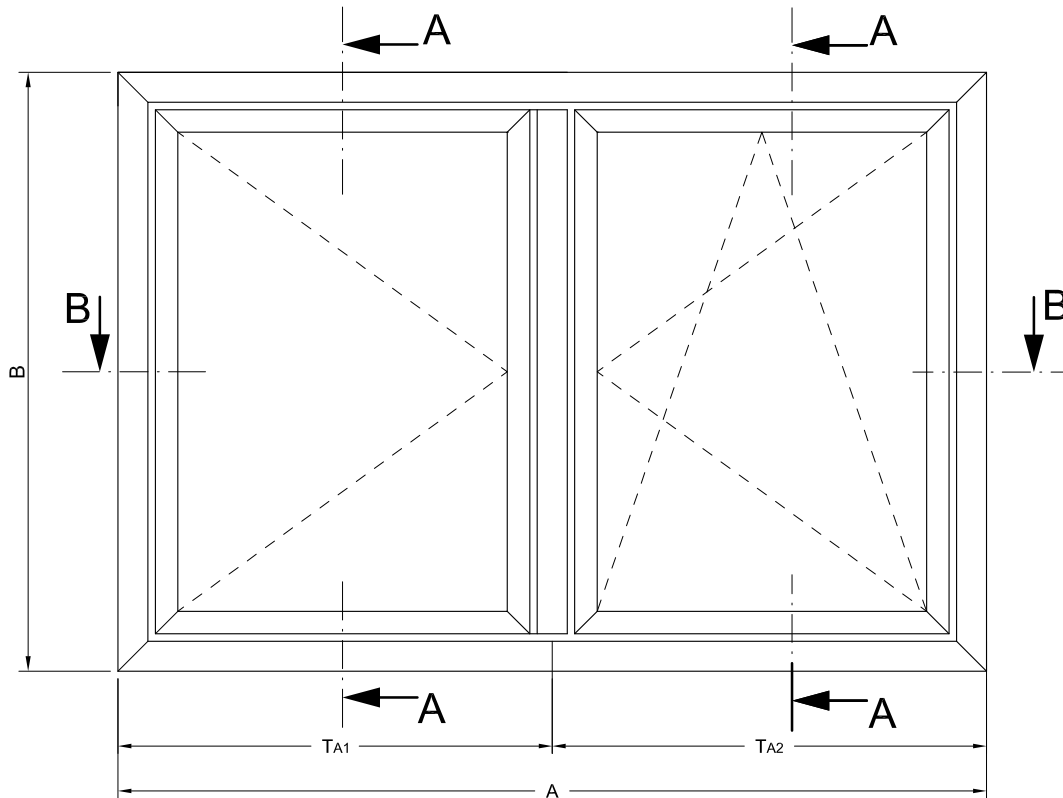

Description	Part no.	X
Frame 49,6	P 815100	27,4
Frame 65,3	P 815104	43,1
Frame 50,3	P 815111	28,1
Frame 66,0	P 815112	43,8

Description	Part no.	Y
Vent 67,5	P 815240	45,3

Description	Part no.	Y
French window part	P 815220	45,3

Description	Part no.	Calculation	Number	Cut
frame horizontal	see profile table	$A = \text{horizontal element dimension}$	2x	
frame vertical	see profile table	$B = \text{vertical element dimension}$	2x	
vent horizontal	P 815240	$V_{A1} = T_{A1} - X + 14$	2x	
	P 815250	$V_{A2} = T_{A2} - X + 14$	2x	
vent vertical	P 815240	$V_B = B - (2 * X) + 12$	3x	
	P 815250			
French window profile vertical	P 815220	$F_{WPB} = V_B + 24$	1x	
glazing bead horizontal	see glazing table	$G_{BH1} = V_{A1} - (2 * Y)$	2x	
		$G_{BH2} = V_{A2} - (2 * Y)$	2x	
glazing bead vertical	see glazing table	$G_{BV} = V_B - (2 * Y) - 44$	4x	



## A-A

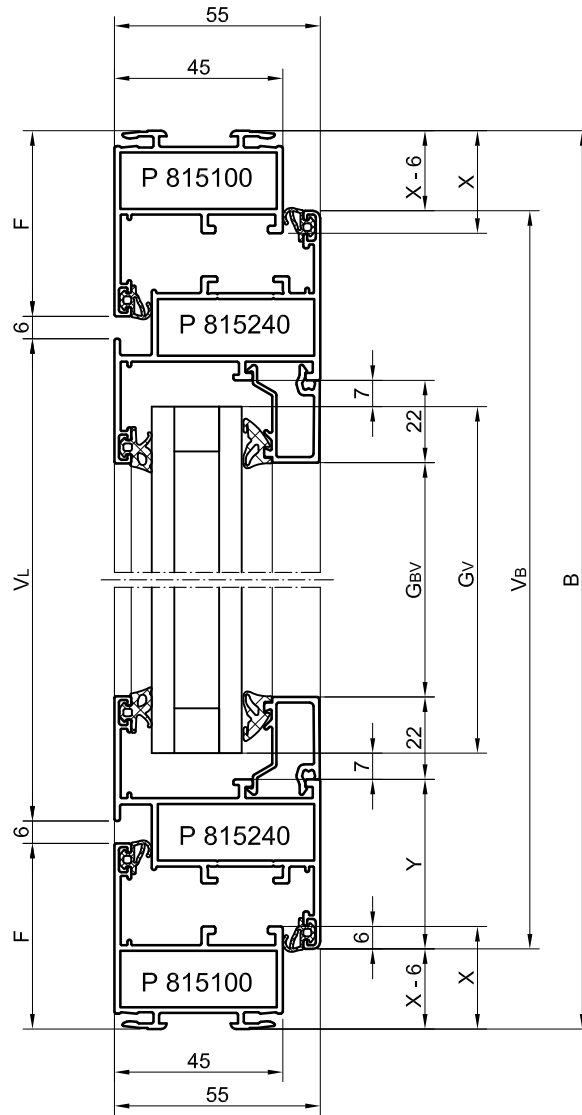

GBH, GBV = see glass dimensions

## B-B

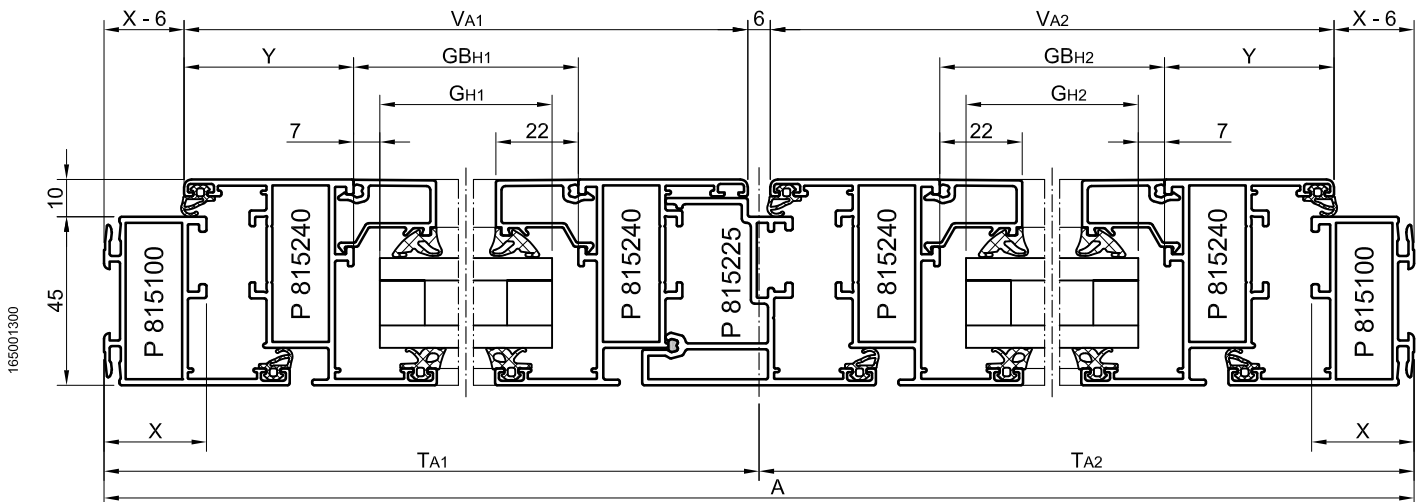

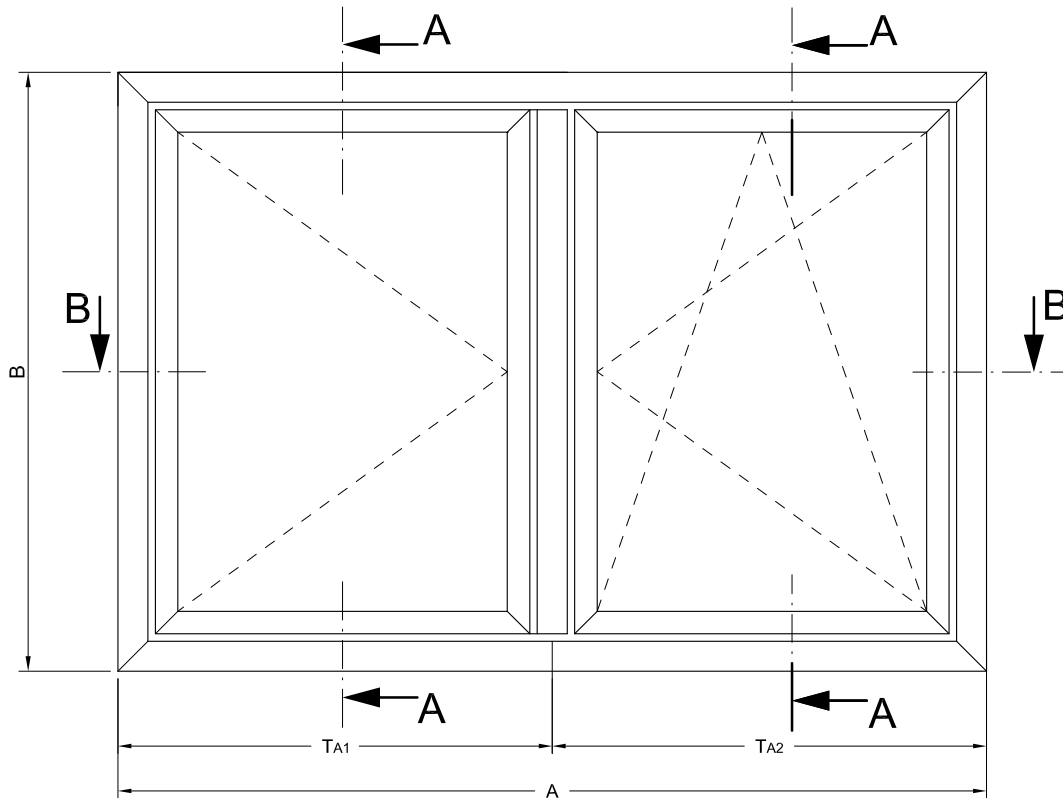

Description	Part no.	X
Frame 49,6	P 815100	27,4
Frame 65,3	P 815104	43,1
Frame 50,3	P 815111	28,1
Frame 66,0	P 815112	43,8

Description	Part no.	Y
Vent 67,5	P 815240	45,3
Vent 95,3	P 815250	73,1

Description	Part no.	Calculation	Number	Cut
frame horizontal	see profile table	$A = \text{horizontal element dimension}$	2x	
frame vertical	see profile table	$B = \text{vertical element dimension}$	2x	
vent horizontal	P 815240	$V_{A1} = T_{A1} - X + 3$	2x	
	P 815250	$V_{A2} = T_{A2} - X + 3$		
vent vertical	P 815240	$V_B = B - (2 * X) + 12$	4x	
	P 815250			
vent vertical adapter profile	P 815225	$V_L = V_B - 68,4$	1x	
glazing bead horizontal	see glazing table	$G_{BH1} = V_{A1} - (2 * Y)$	2x	
		$G_{BH2} = V_{A2} - (2 * Y)$		
glazing bead vertical	see glazing table	$G_{BV} = V_B - (2 * Y) - 44$	4x	

166001400

inward opening

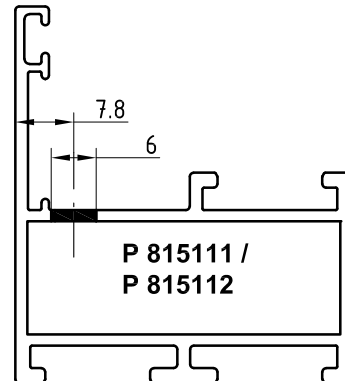
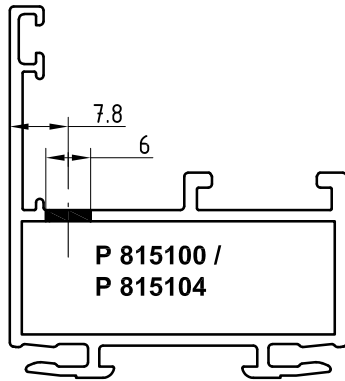

**Detail: Z**

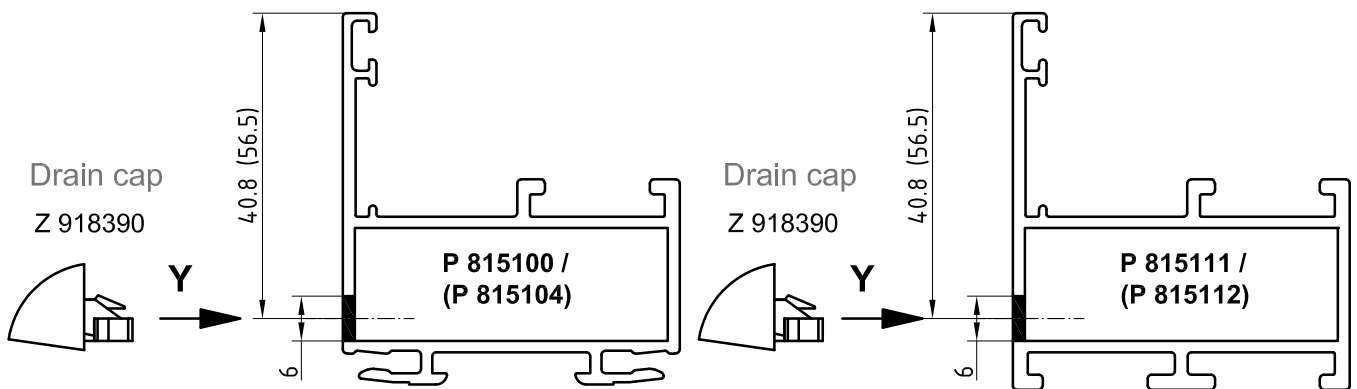
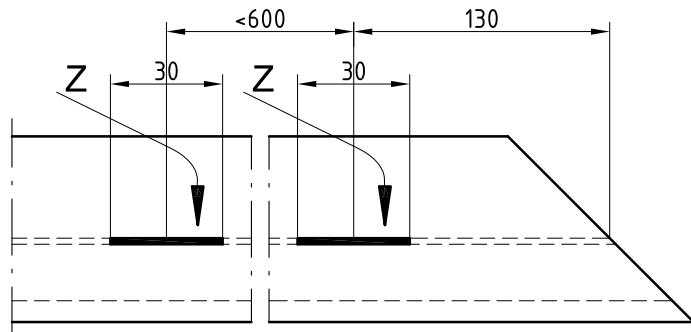
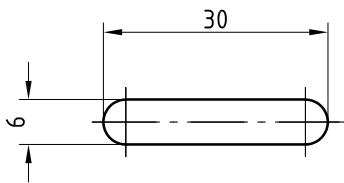

**Detail: Y**

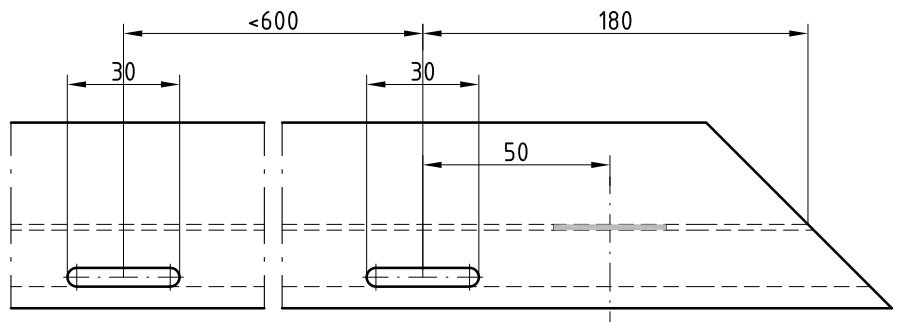
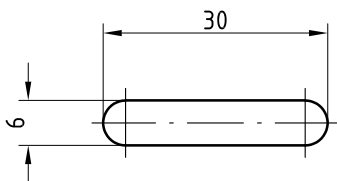

167001500

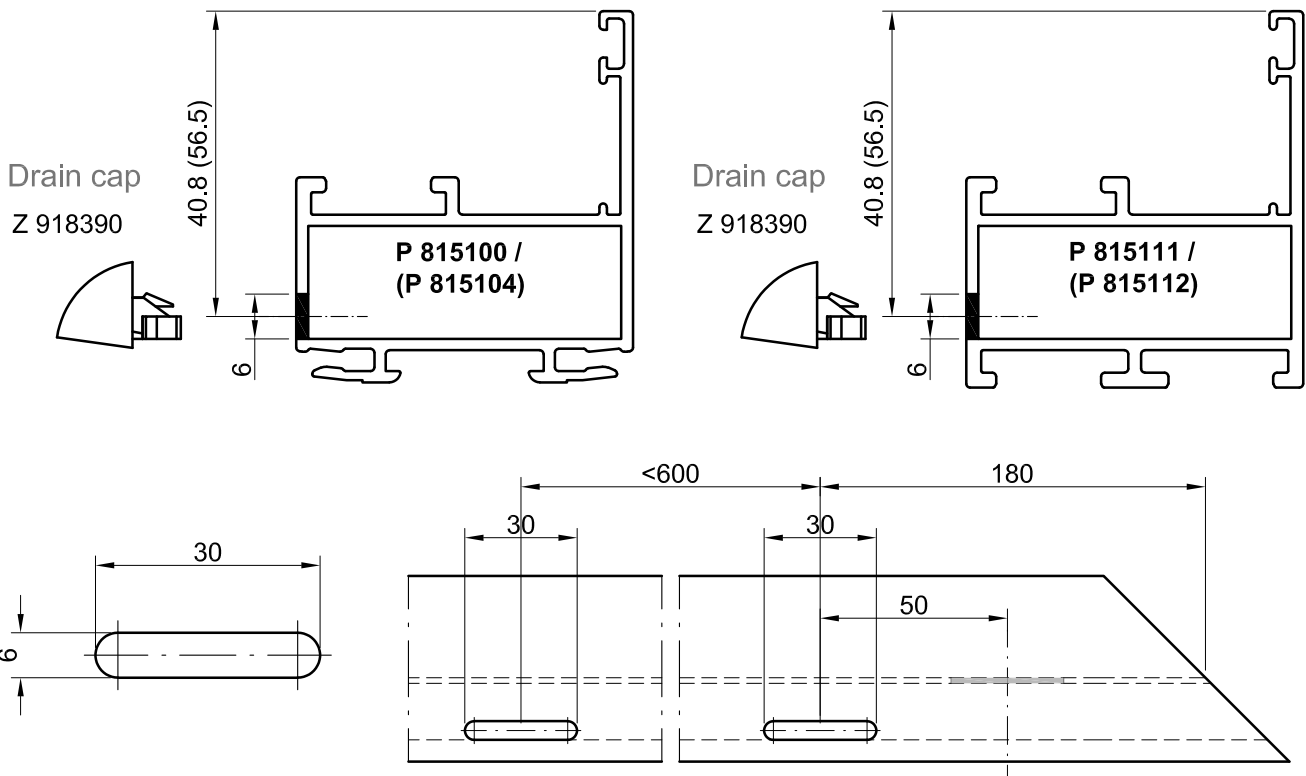
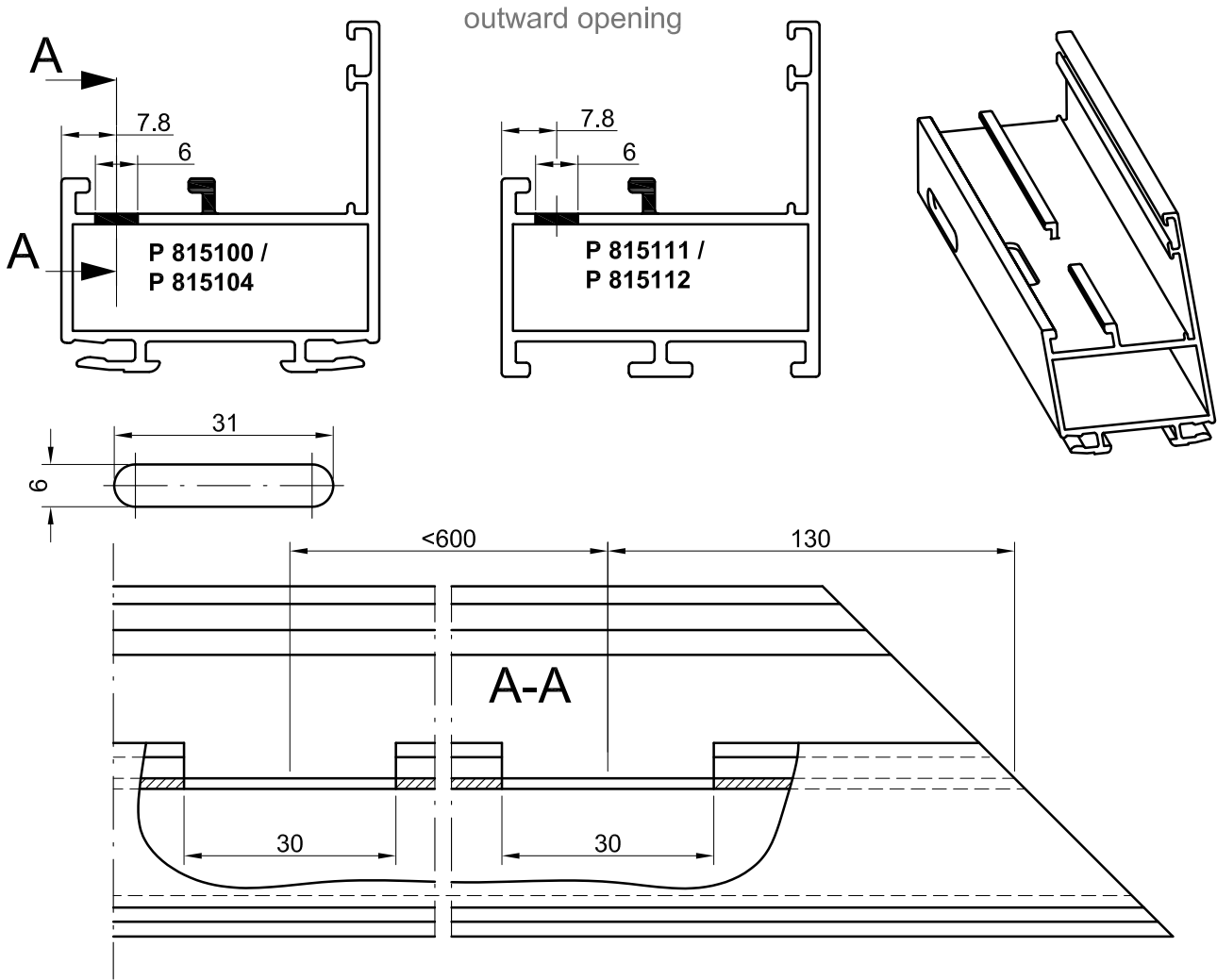

168001600

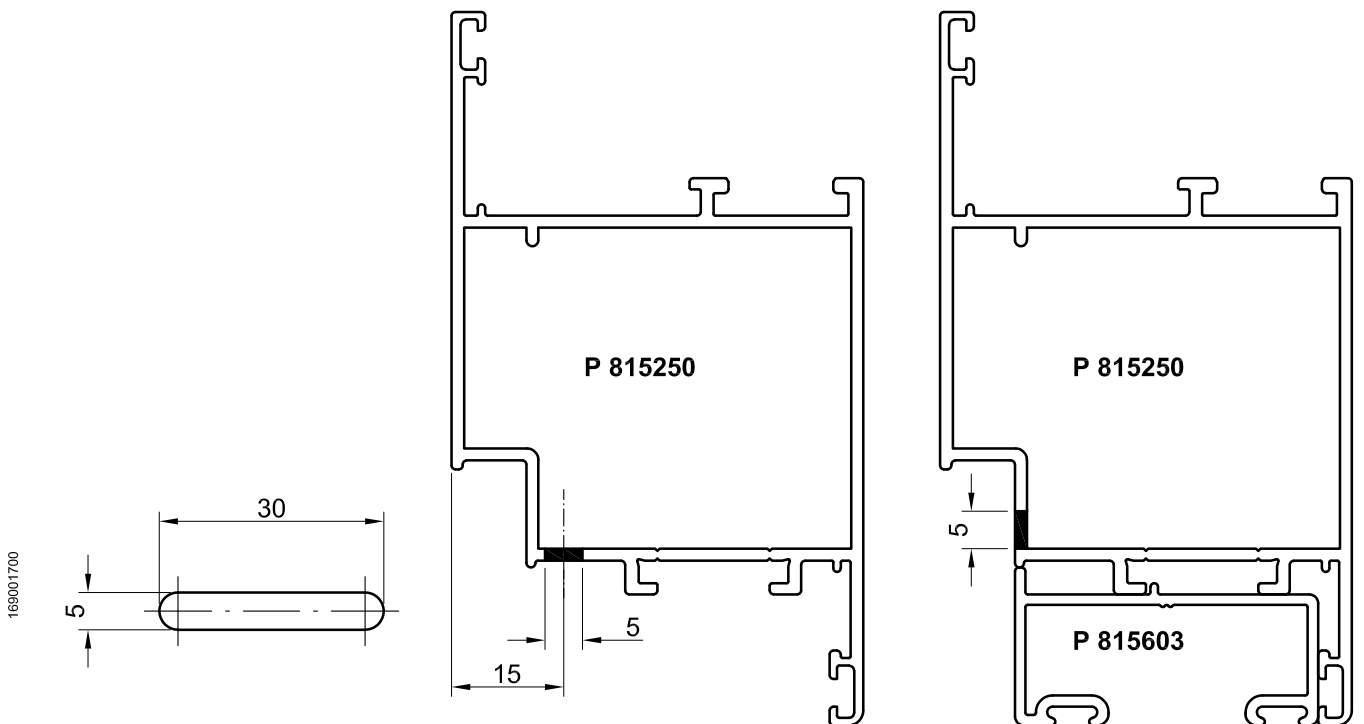
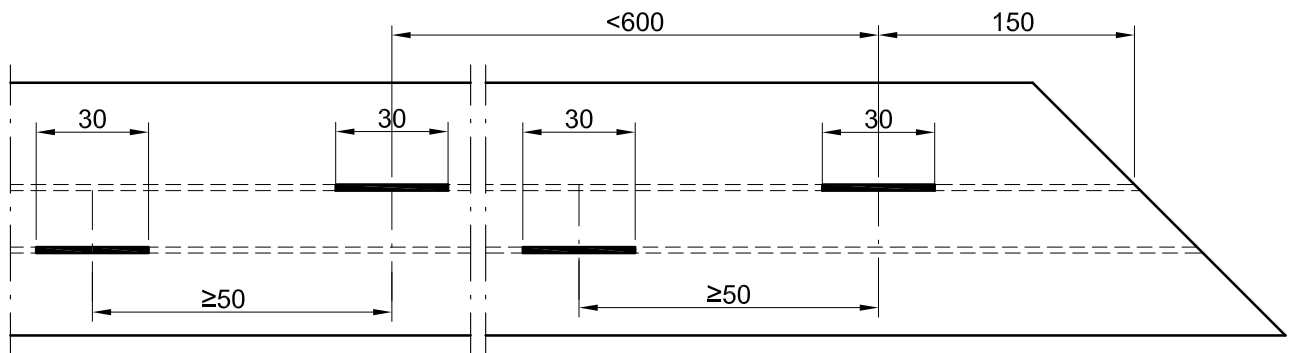
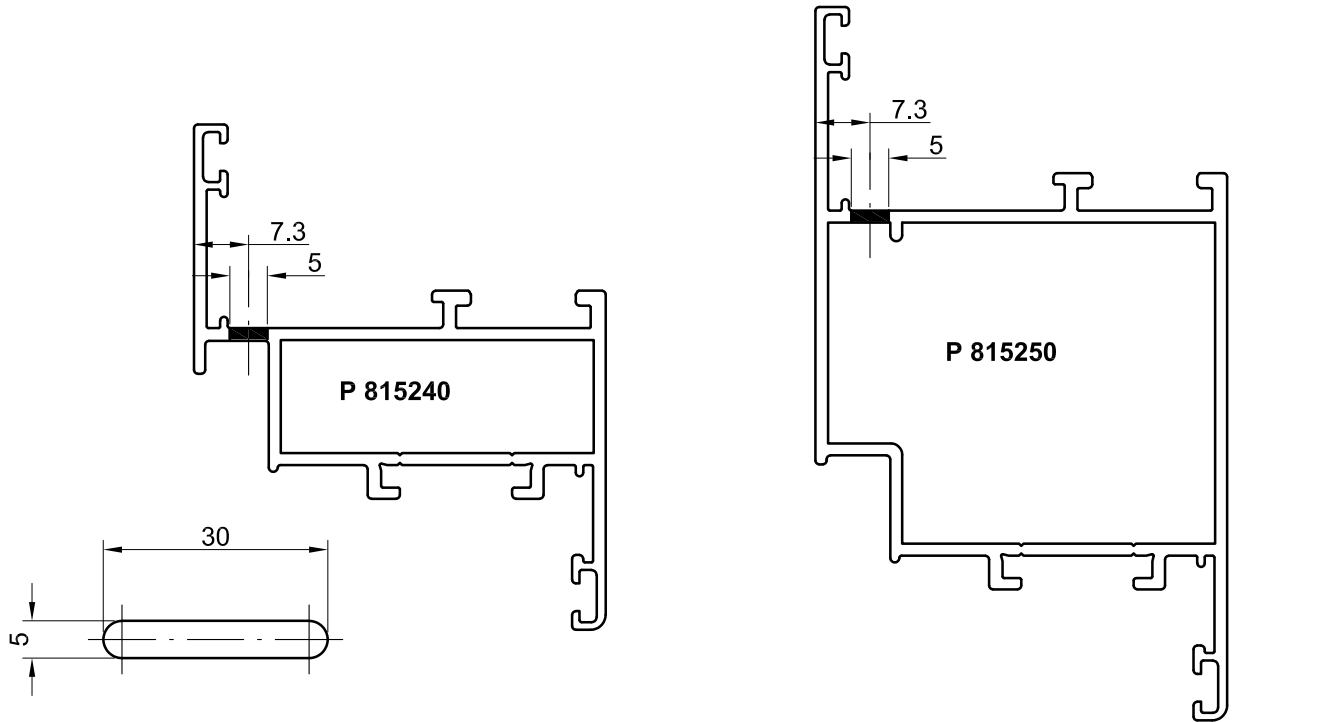

169001700

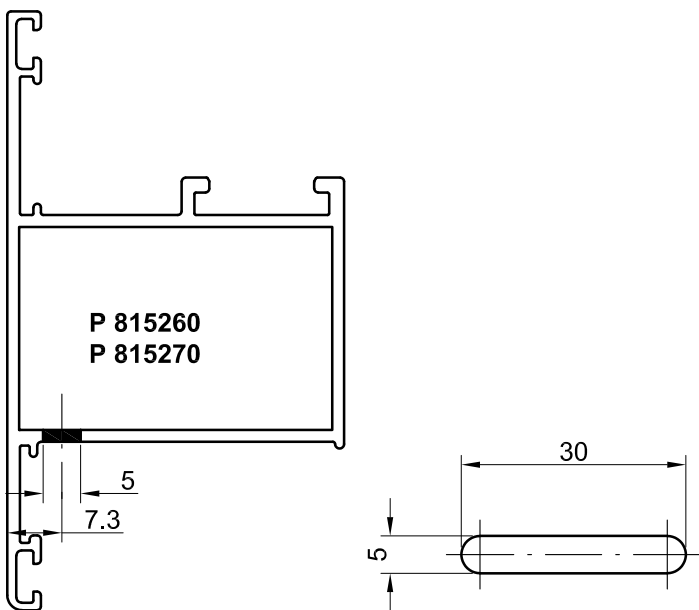
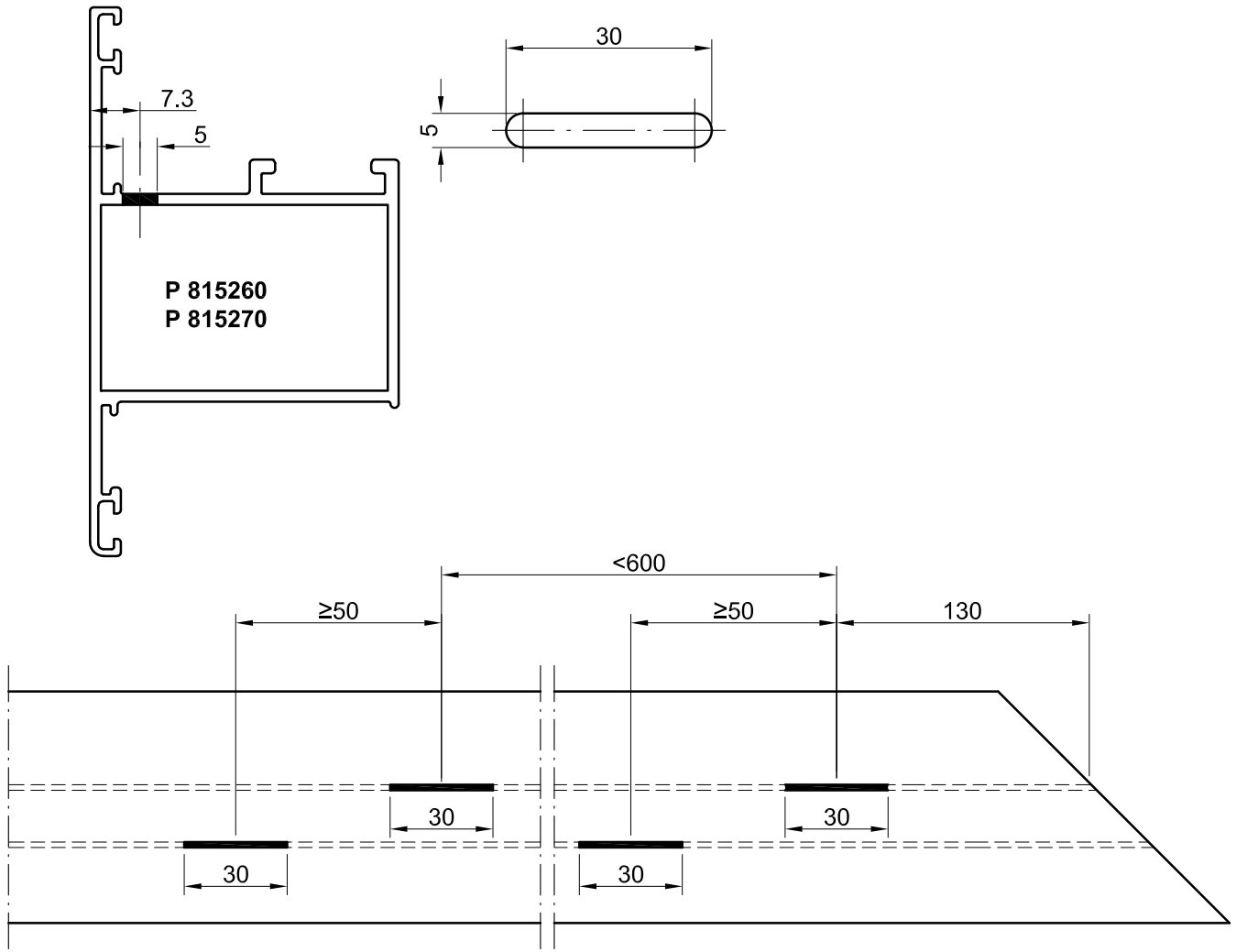

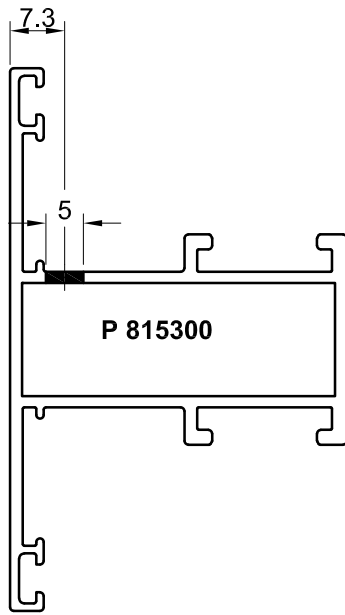

**Detail: Y**

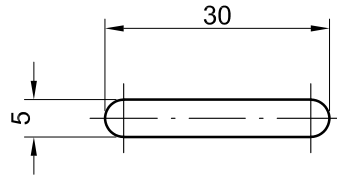

Y

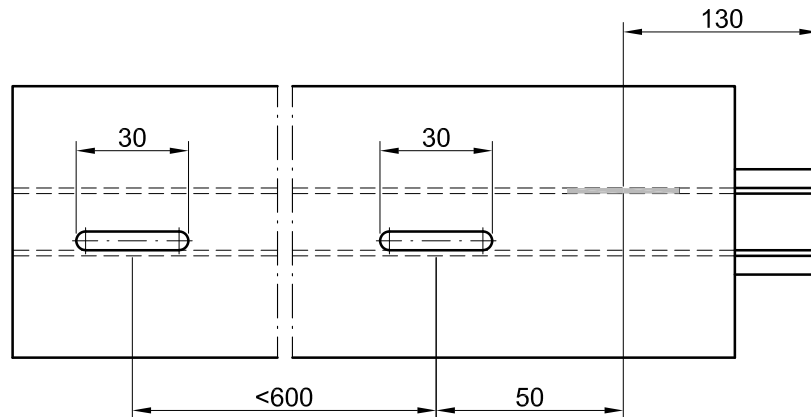
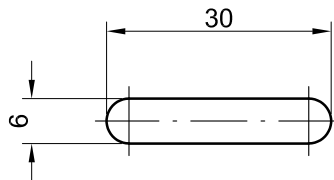
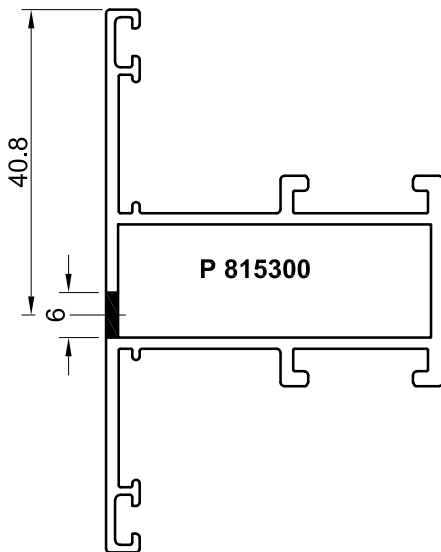
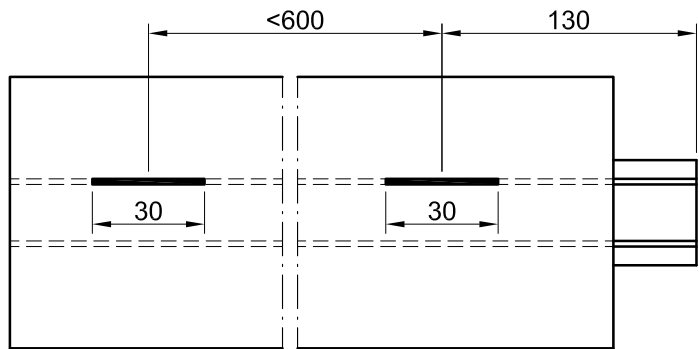

171001900

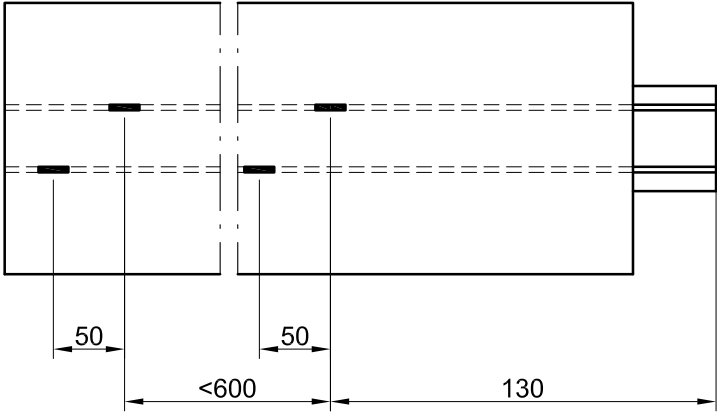
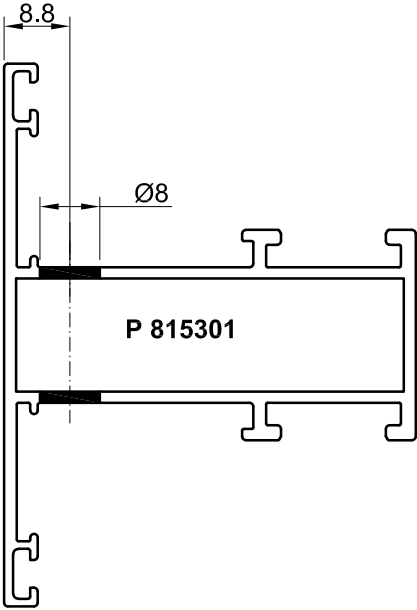



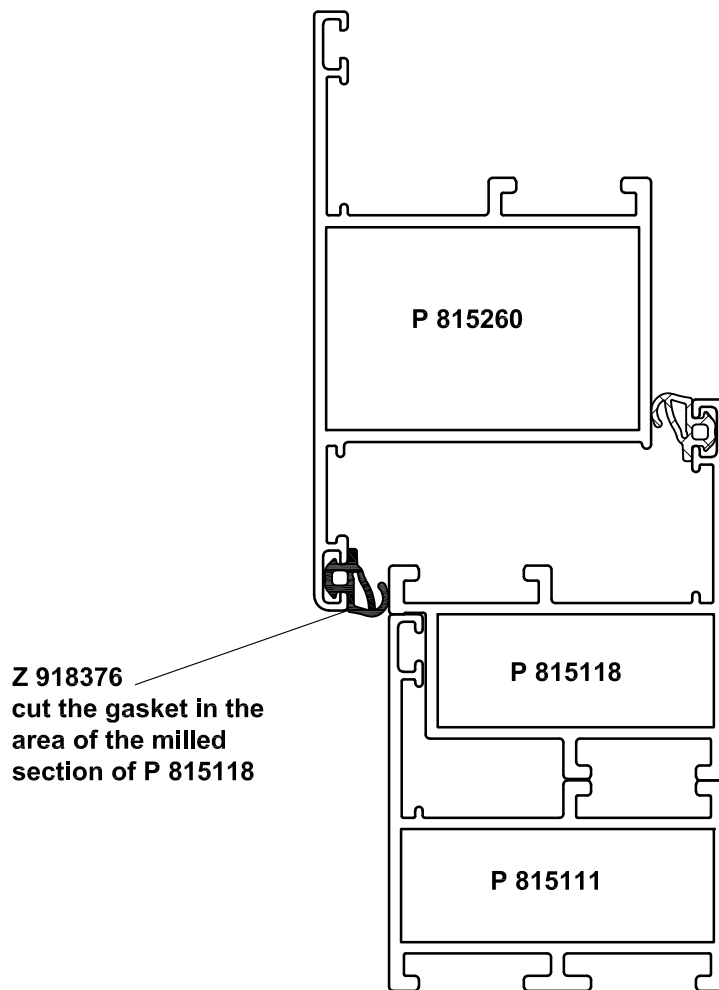
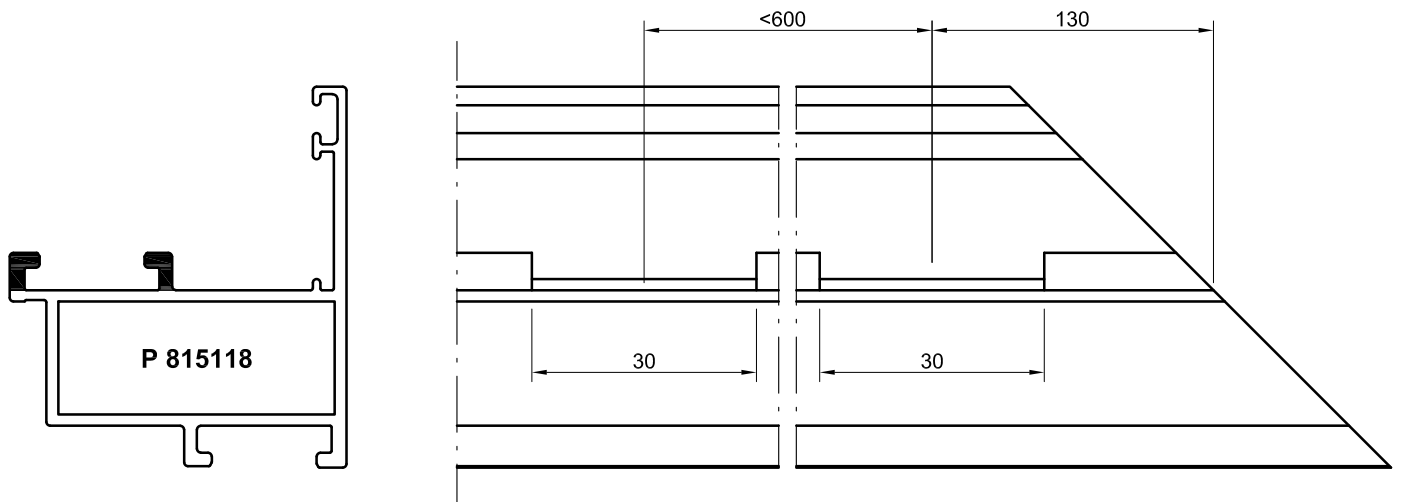

173002100

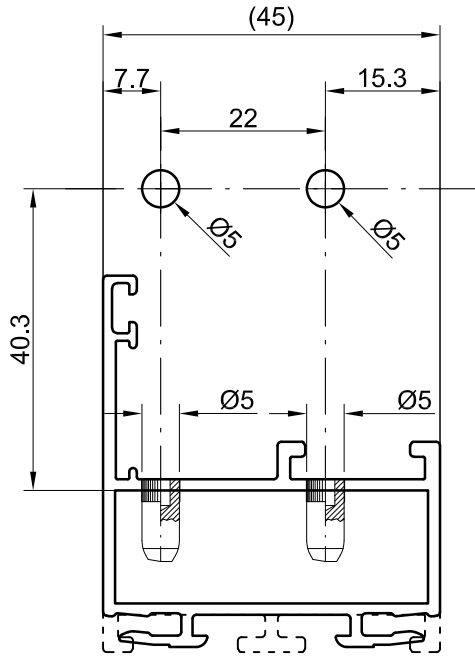

**P 815100 / P 815111**  
pattern of drilling

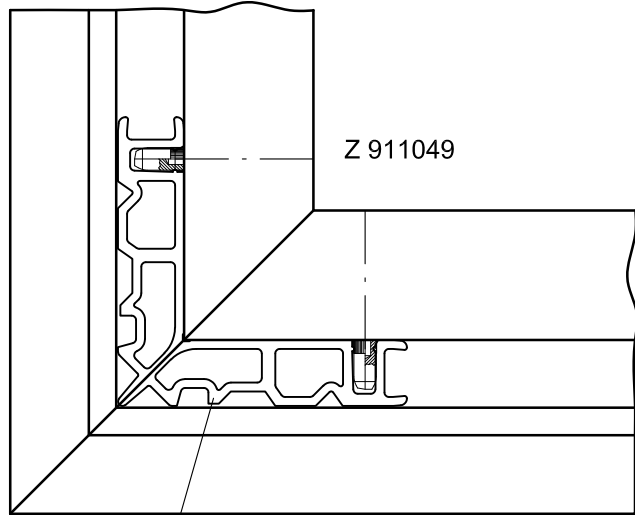

Z 918394

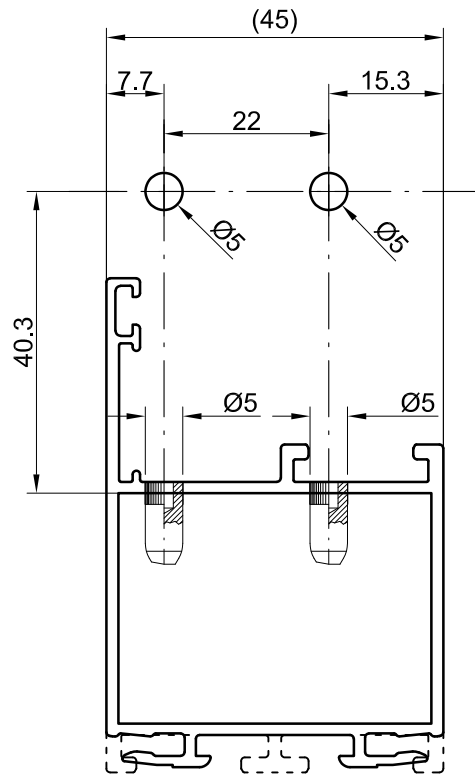

**P 815104 / P 815112**  
pattern of drilling

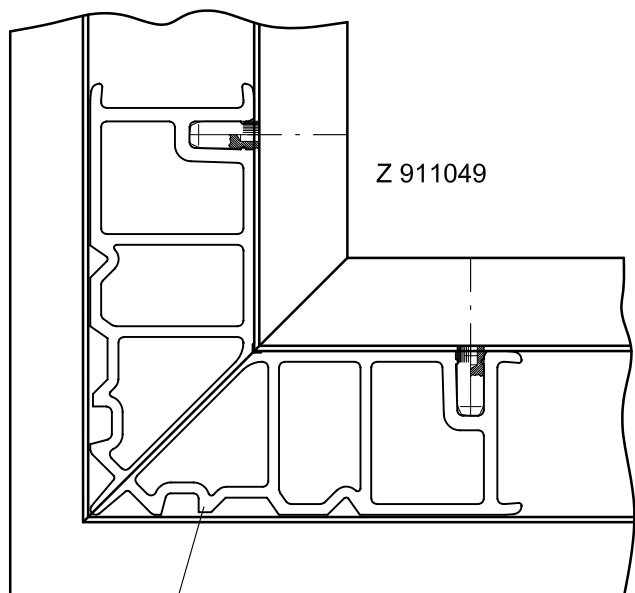

Z 918601

174002100

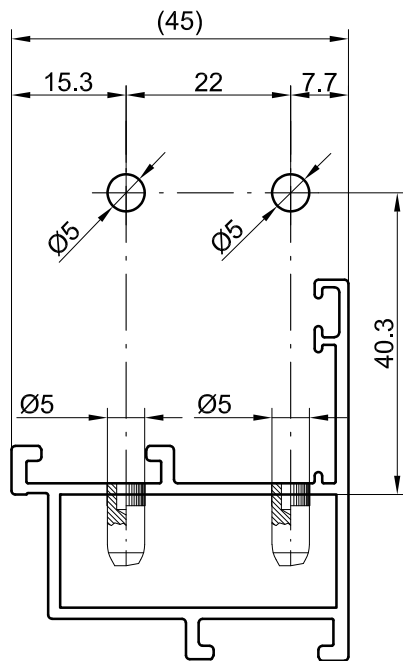

pattern of drilling  
P 815118

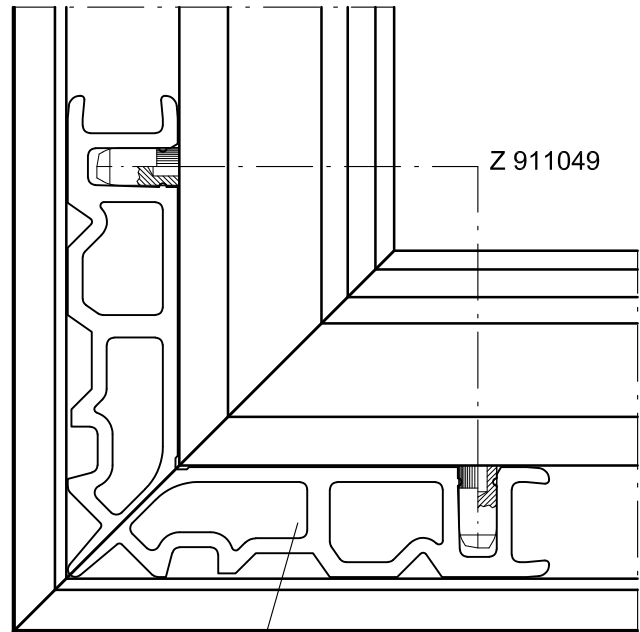

Z 918394

Z 911049

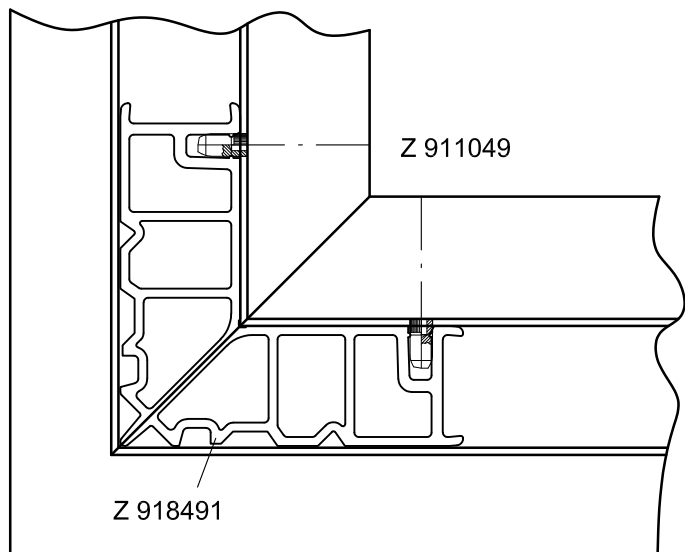
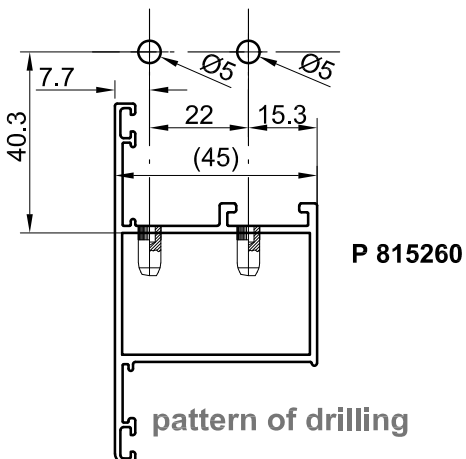
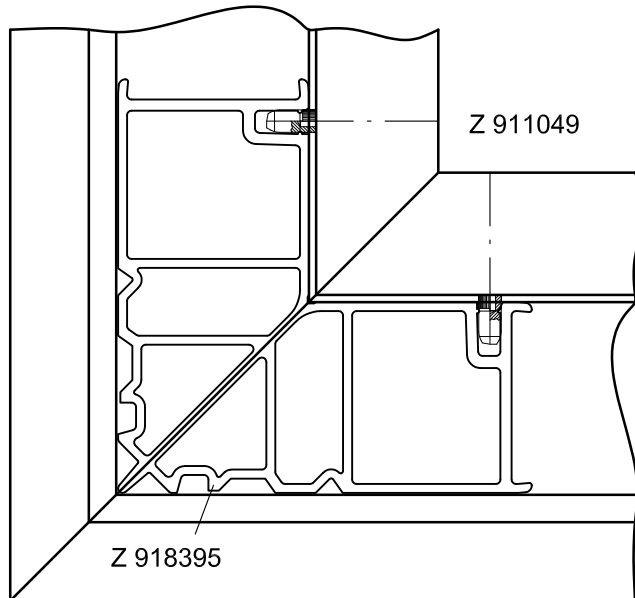
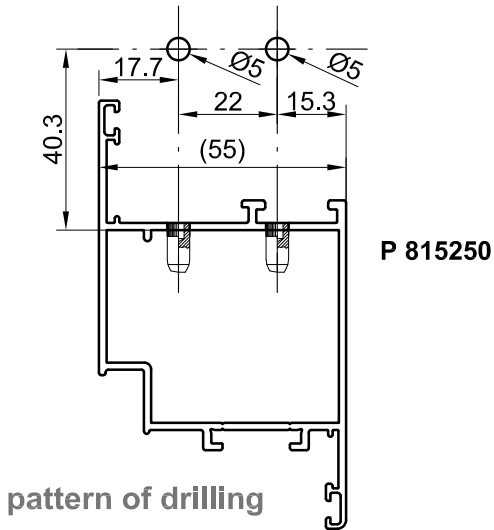
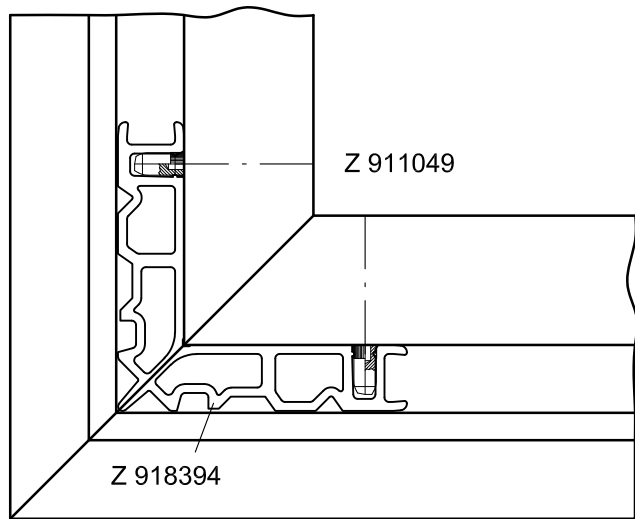
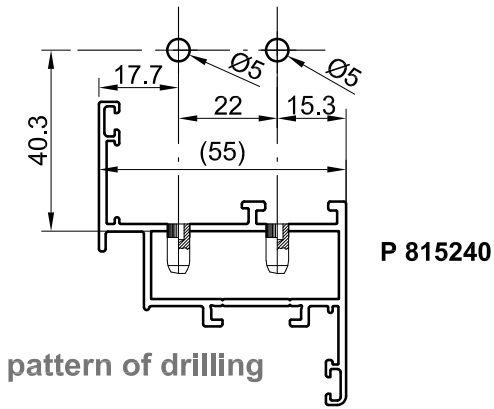

176002200

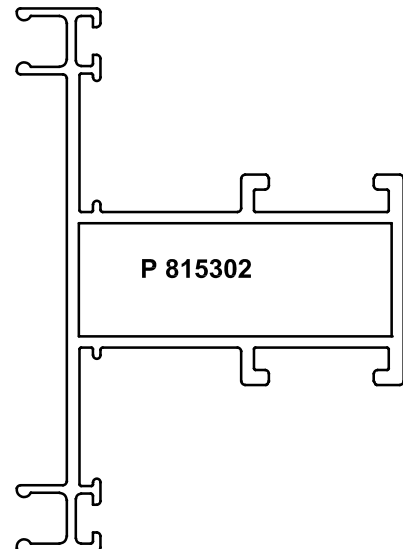
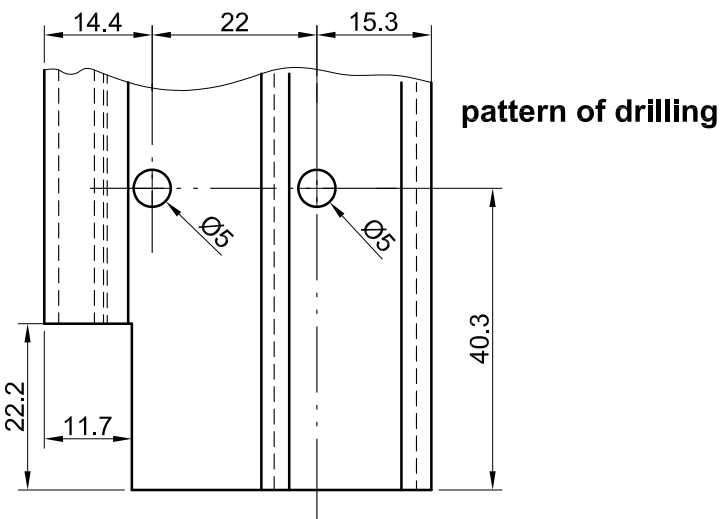
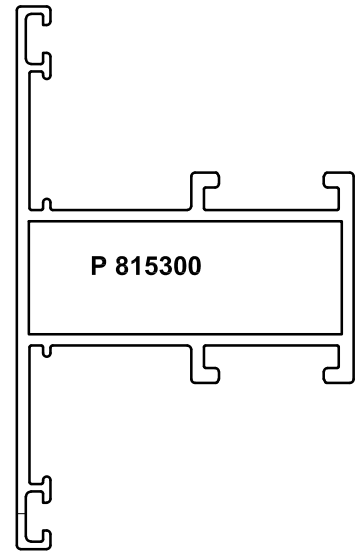
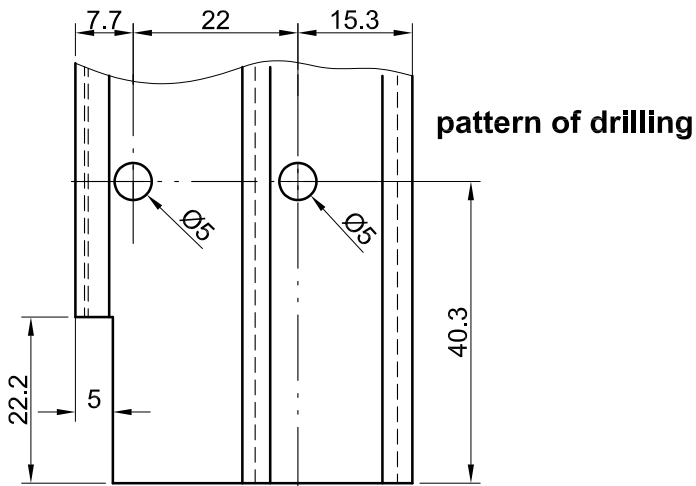
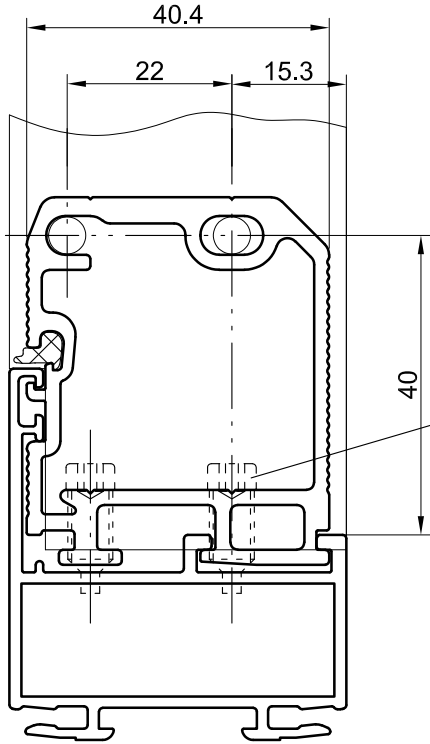

177002300

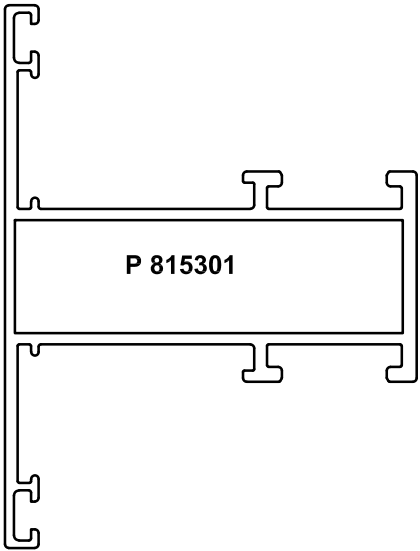
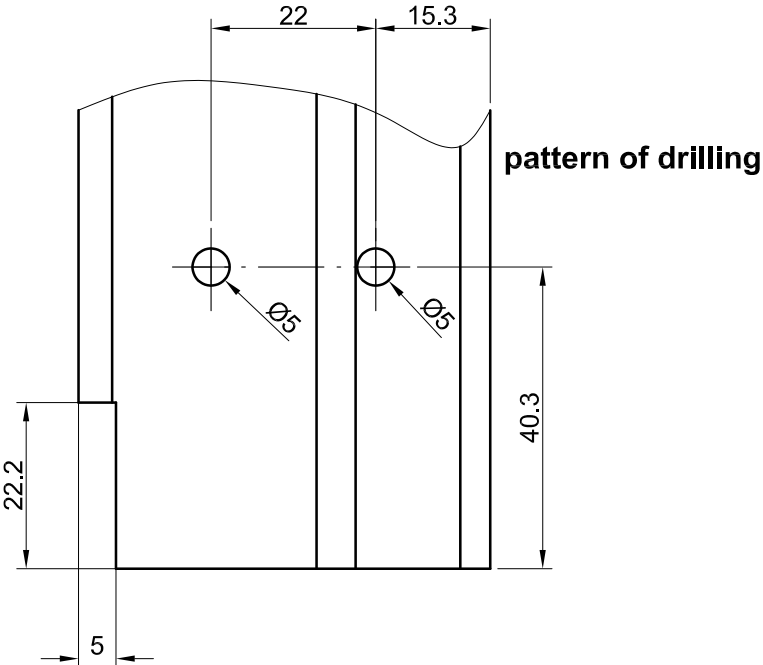
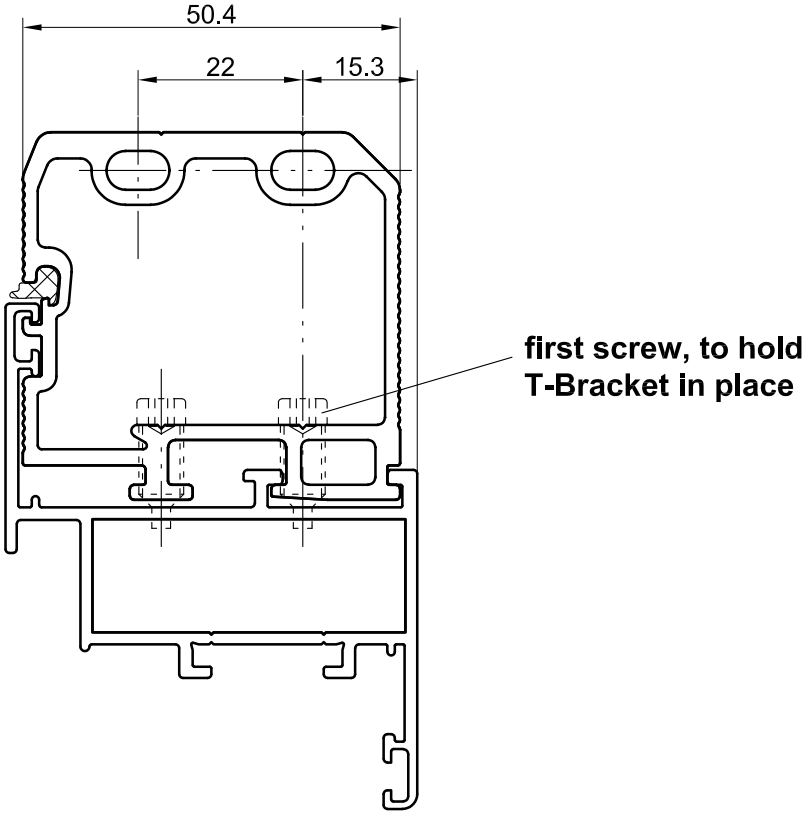

178002400

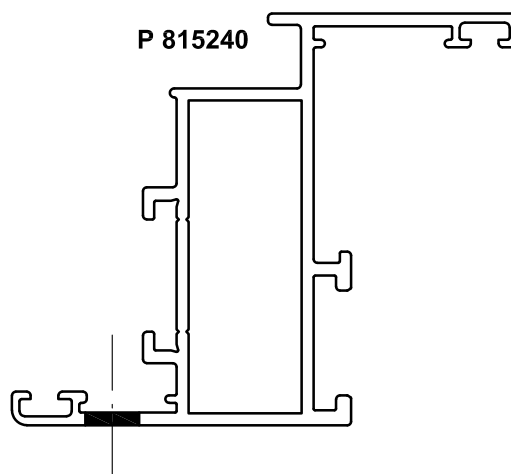
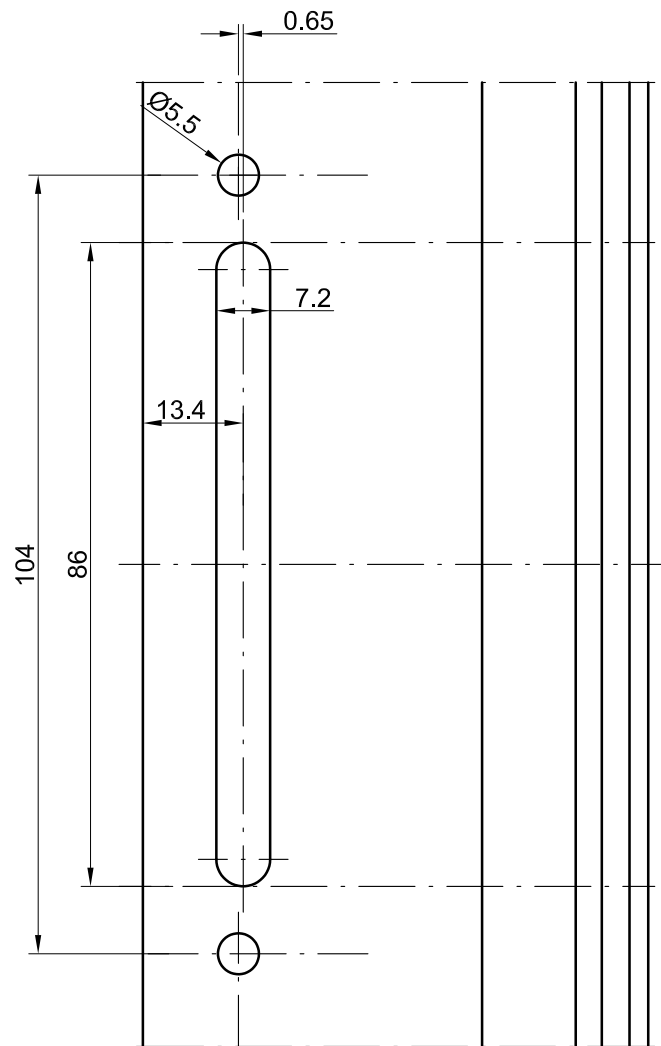

179002500

Detail: Z

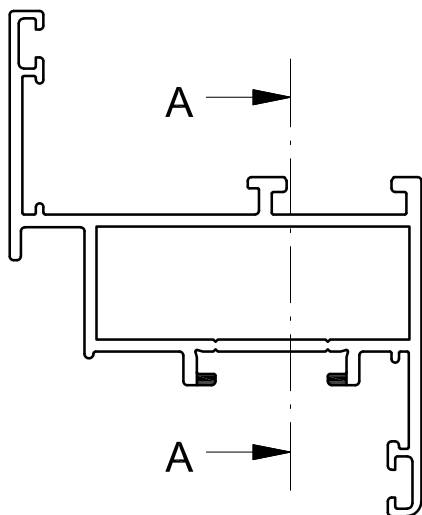
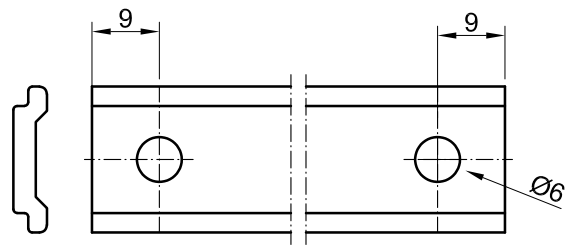
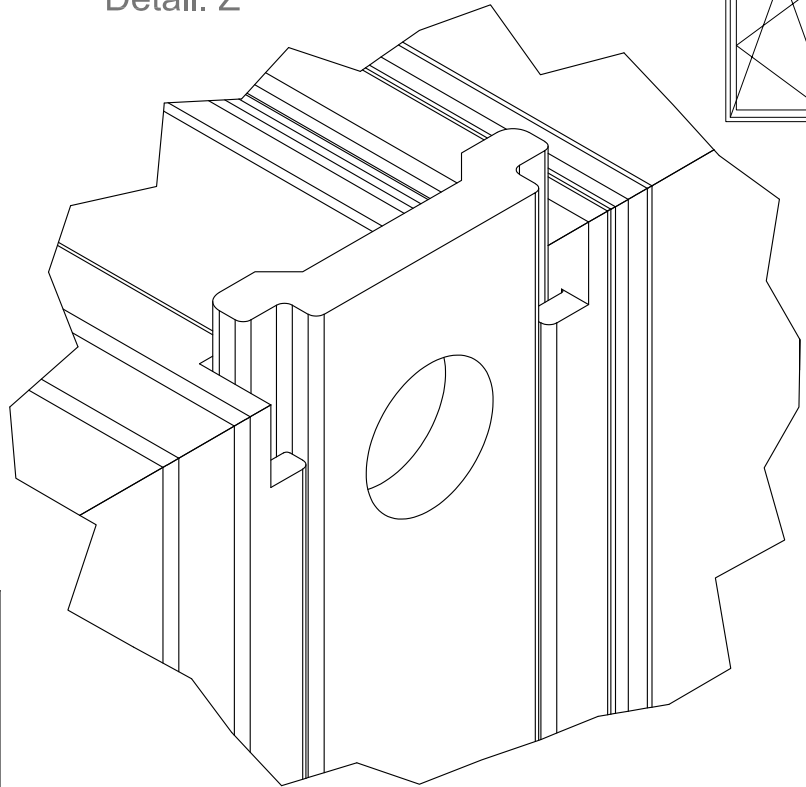
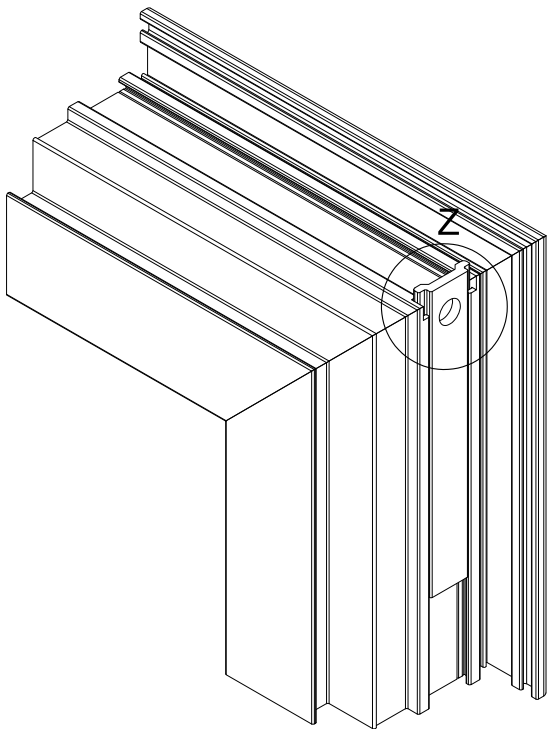
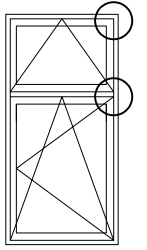

A-A (1:1)

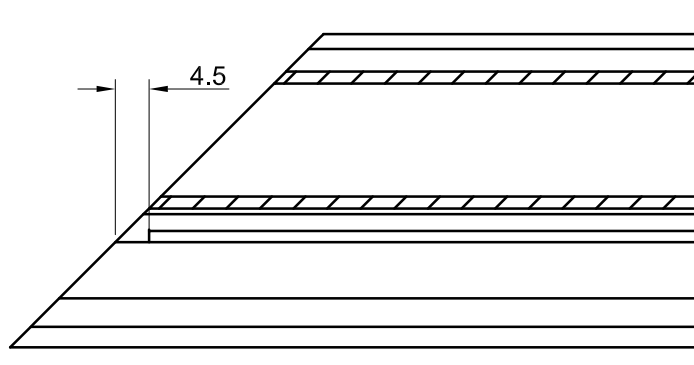

180002600



### Processing steps

- 1) Saw the profile
- 2) Drill / Mill the holes
- 3) Seal the cut surface  
Z912717  
Z912718
- 4) Insert the glue (Z911737)
- 5) Slide in the corner braket
- 6) Slide in the corner stabiliser
- 7) Assemble the corner with pin or crimp

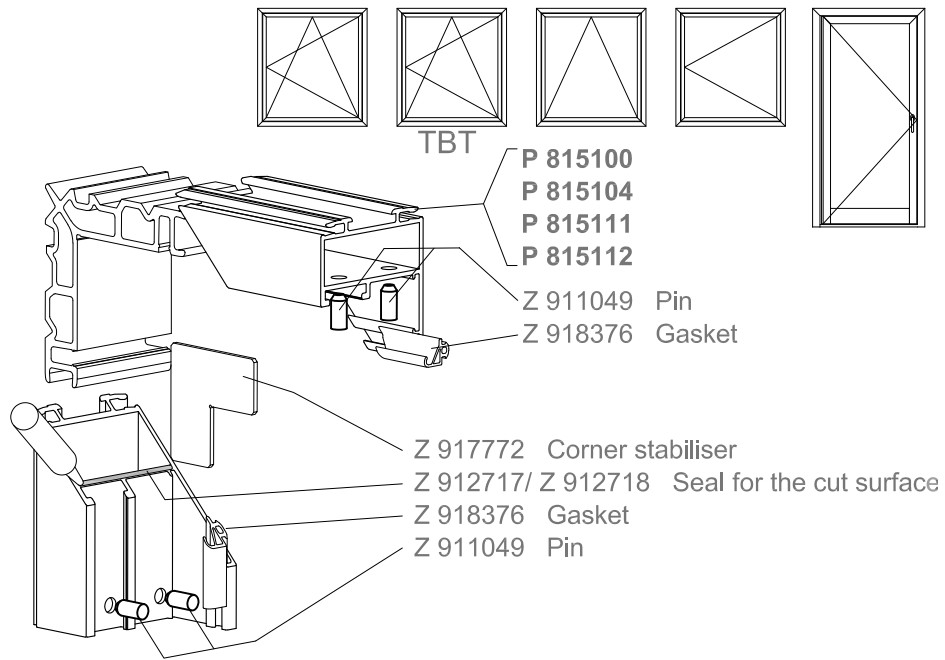

Window opening inside

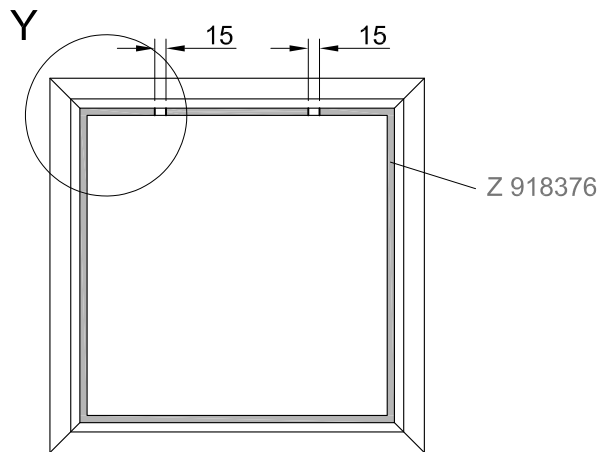

Window opening outside

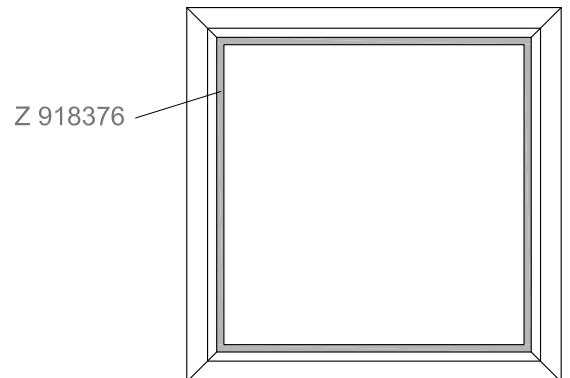

Y 1:3

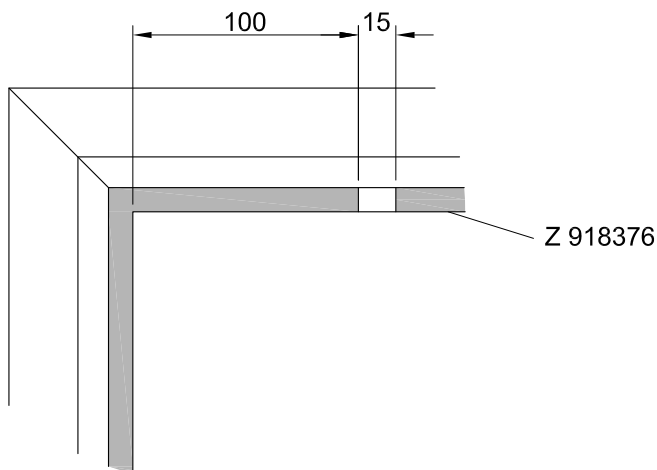

door opening inside

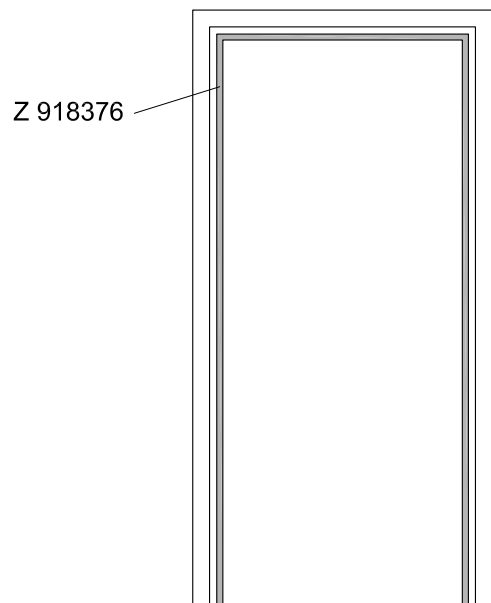

181002700

### Processing steps

- 1) Saw the profile
- 2) Drill / Mill the holes
- 3) Seal the cut surface  
Z912717  
Z912718
- 4) Insert the glue (Z911737)
- 5) Slide in the corner braket
- 6) Slide in the corner stabiliser
- 7) Assemble the corner with pin or crimp

Z 912217  
Z 912718



P 815240  
P 815250

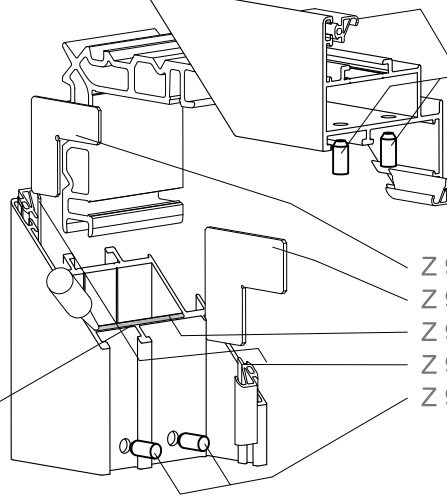

Z 911049 Pin  
Z 918376 Gasket  
  
Z 917774 Corner stabiliser  
Z 917772 Corner stabiliser  
Z 912717 Seal the cut surface  
Z 918376 Gasket  
Z 911049 Pin

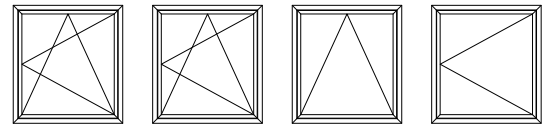

TBT

### Window sash opening inside

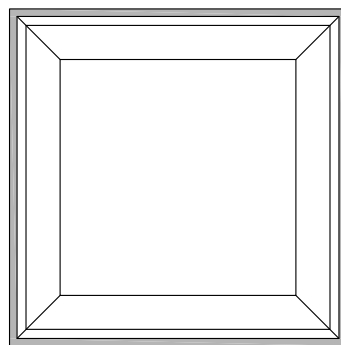

Z 918376

### Window sash opening outside

Z 918376

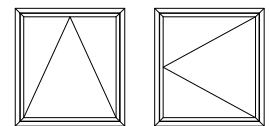
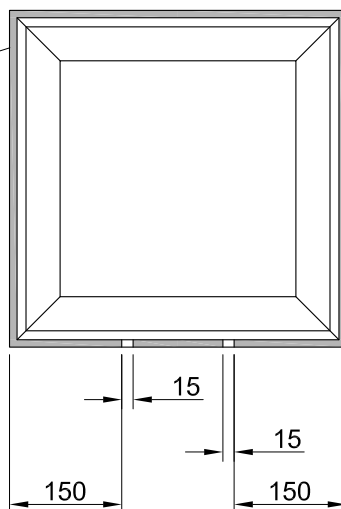

### Processing steps

same like frame

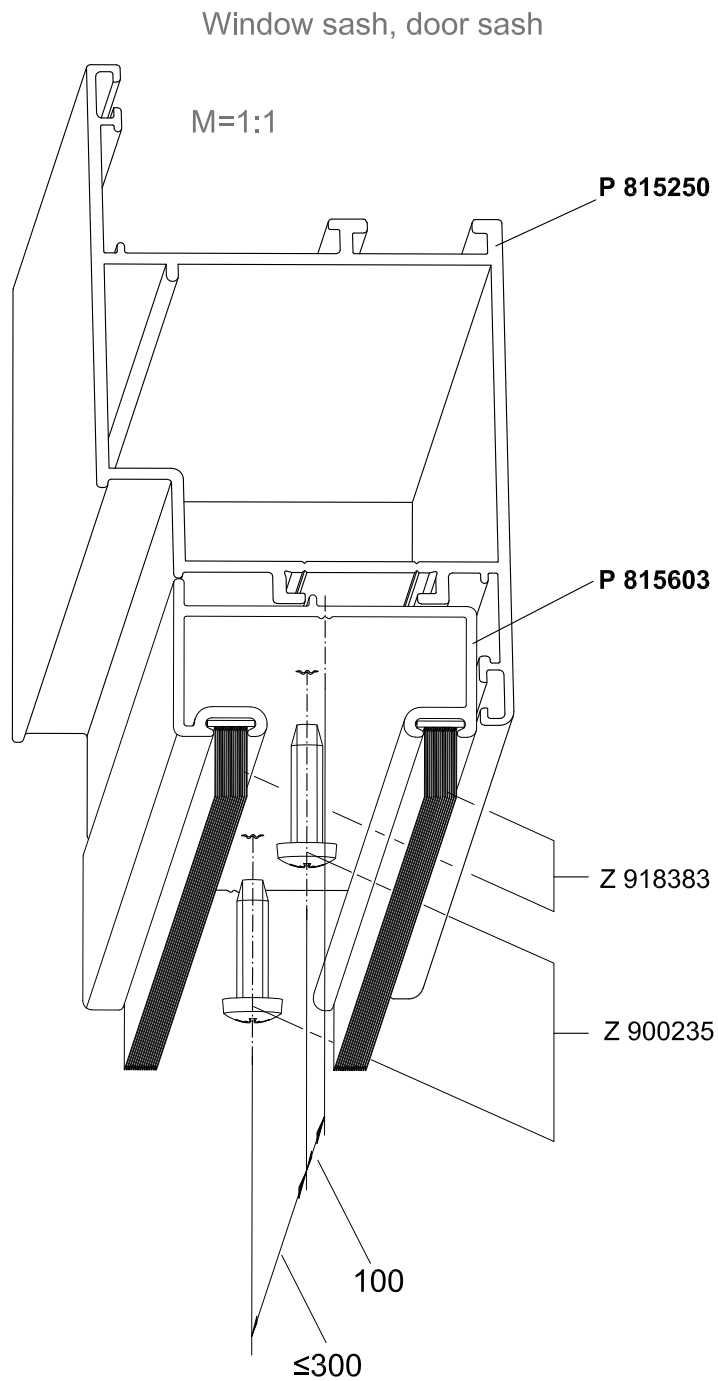

183002900

### Processing steps

Window sash, door sash

same like frame

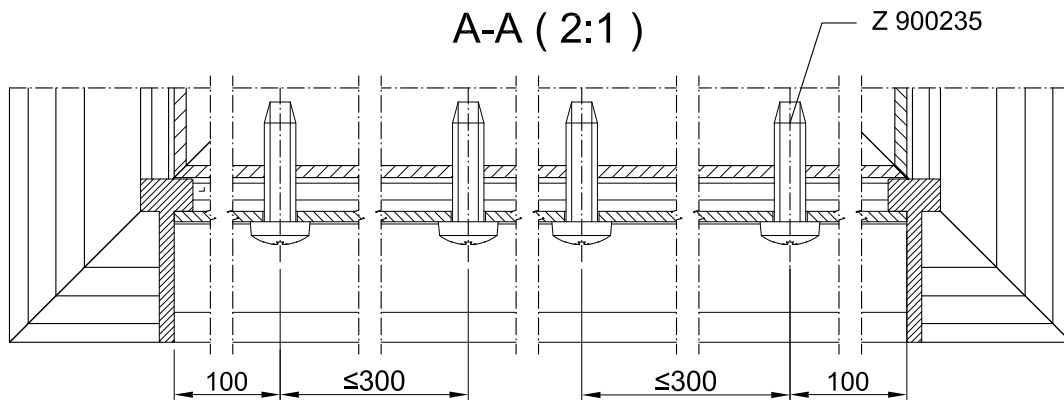
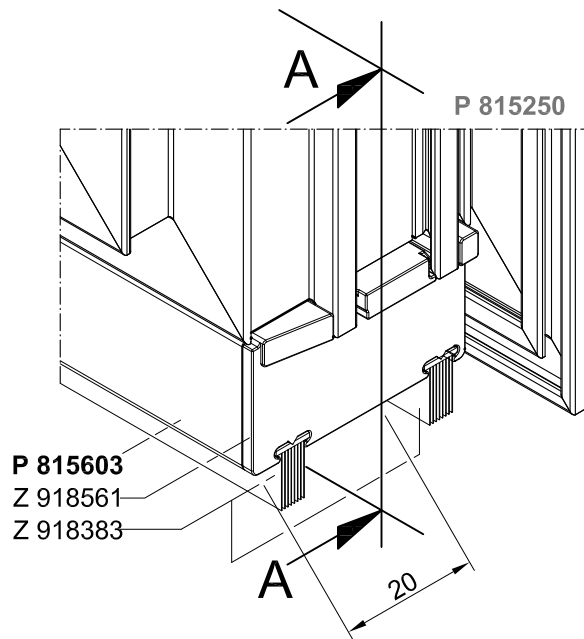
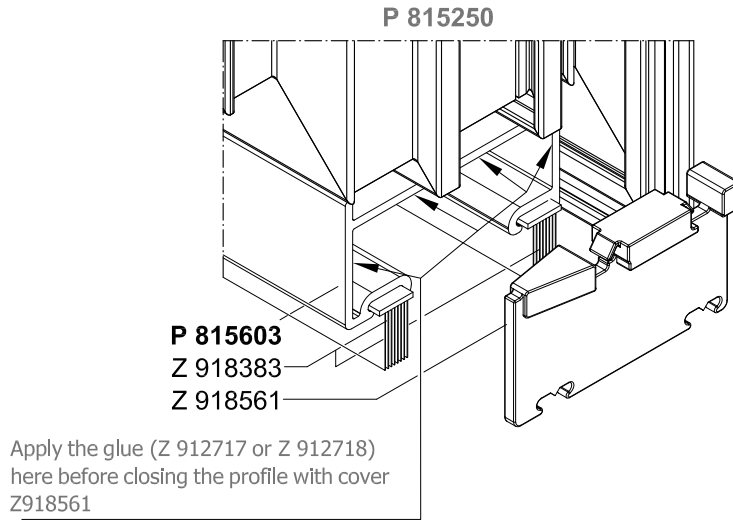

184003000

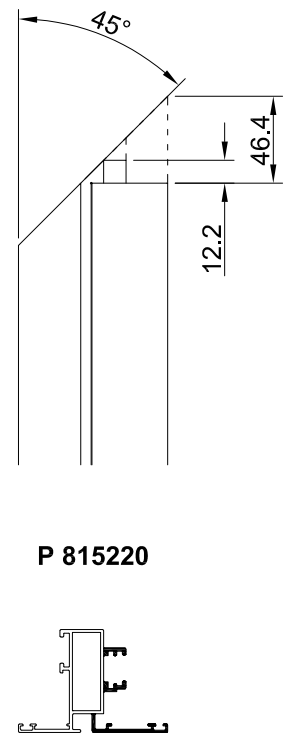
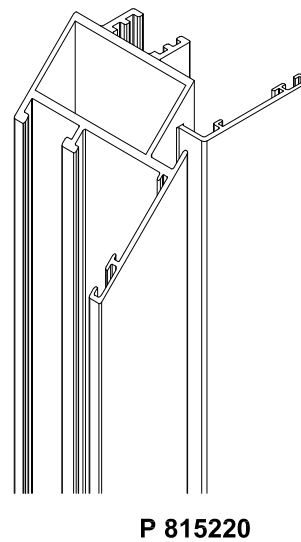
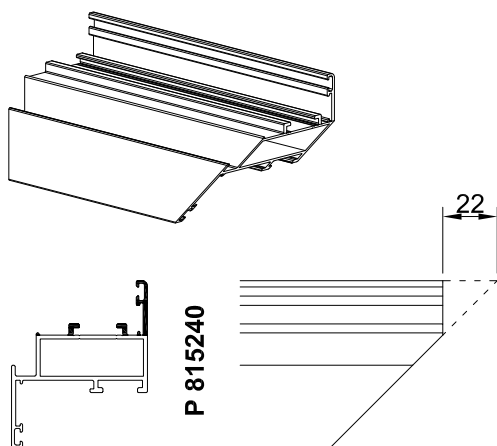
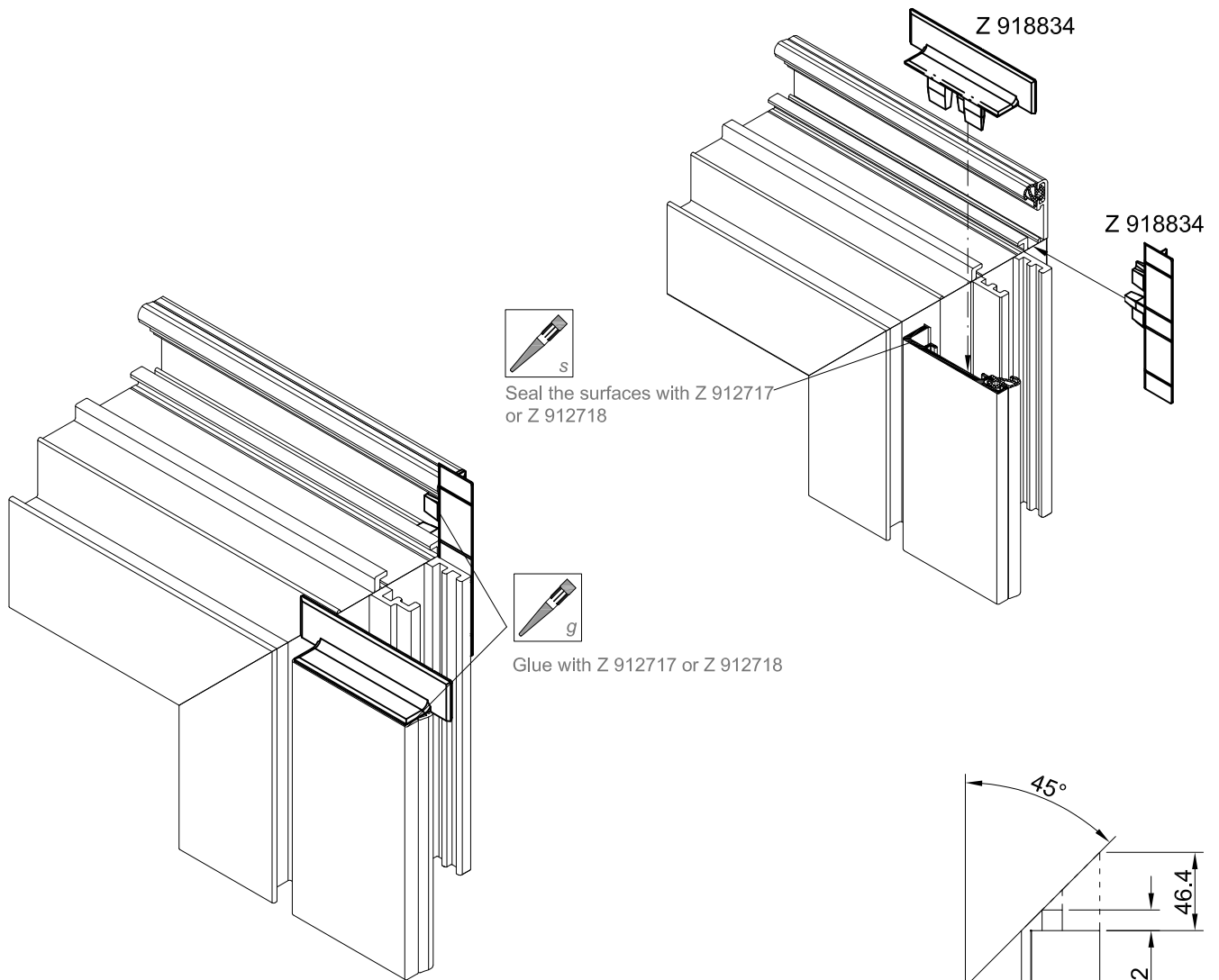
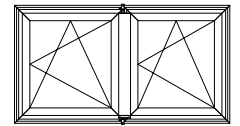

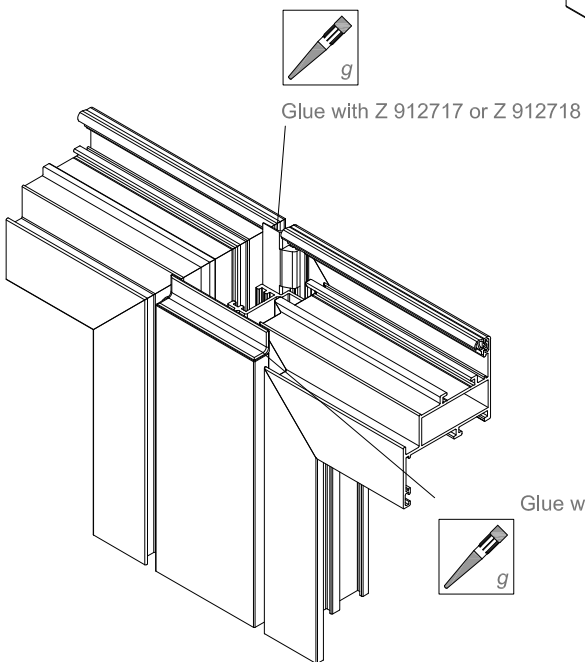
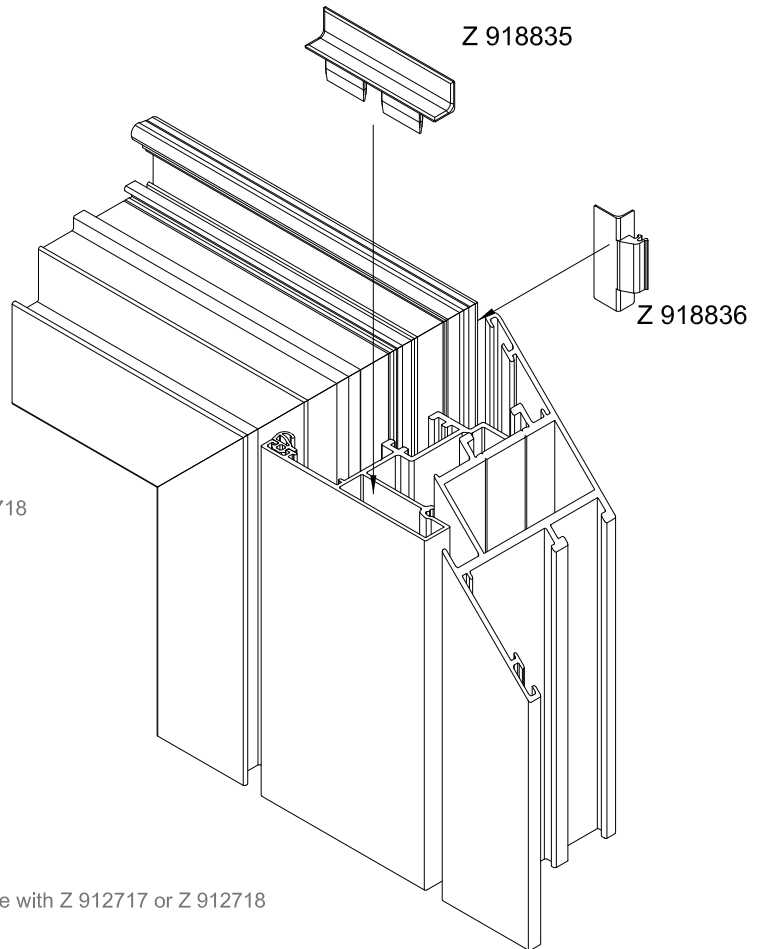
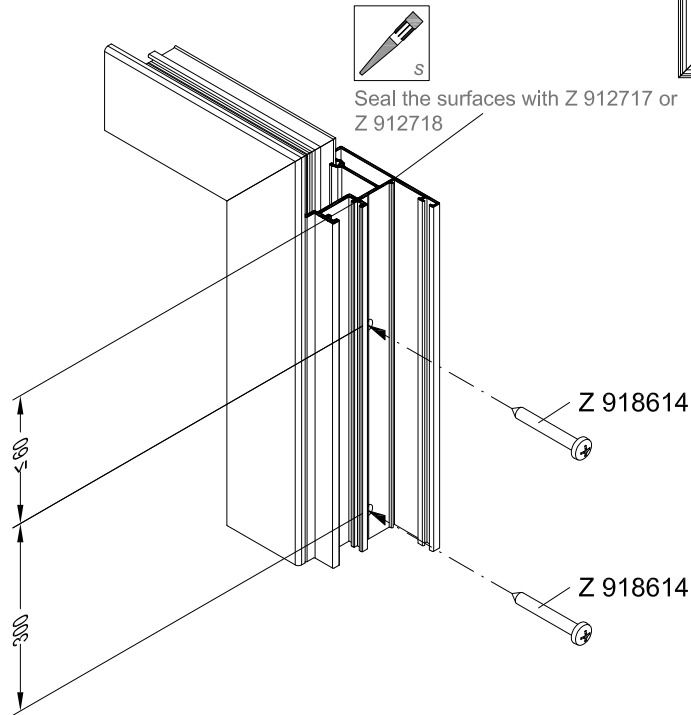
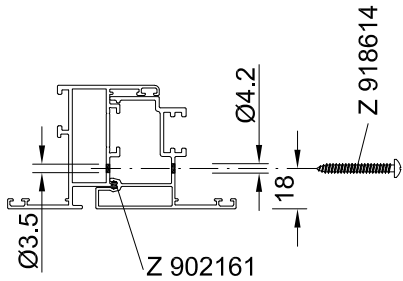
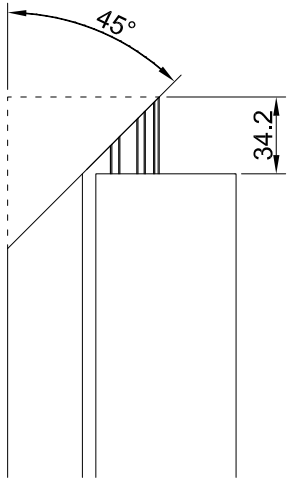
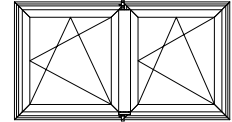

186003200

### Processing steps

see like frame

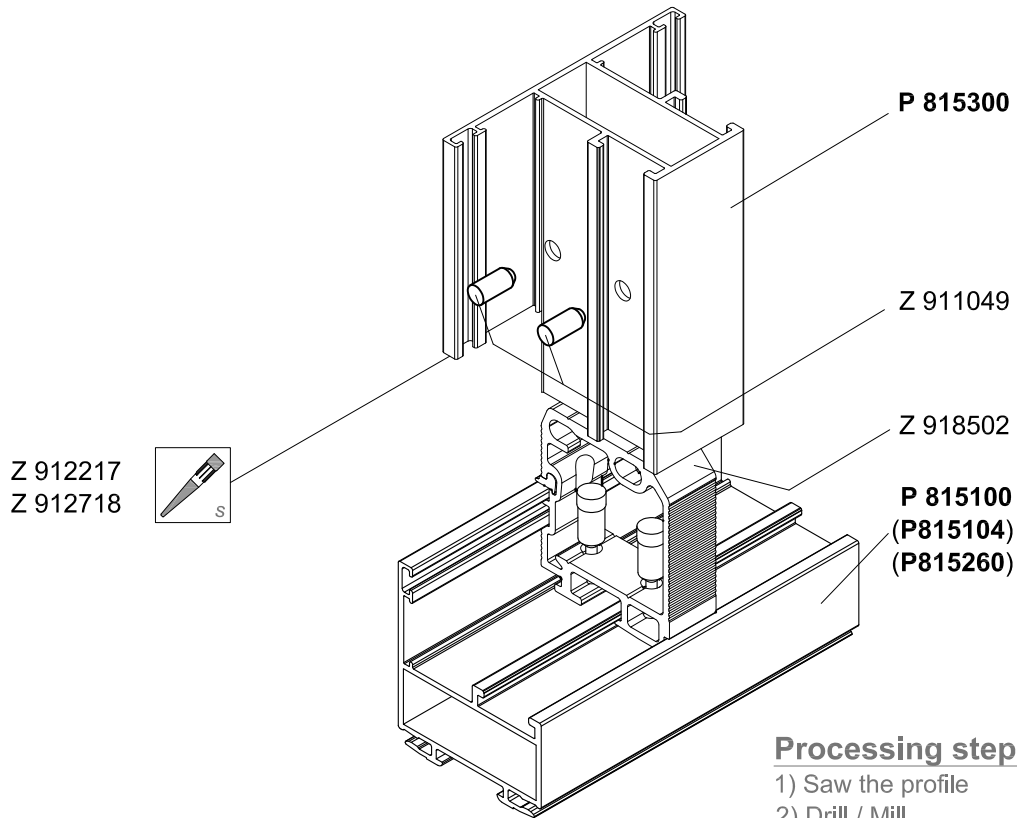

### Processing steps

- 1) Saw the profile
- 2) Drill / Mill
- 3) Seal the cut surface (z 912717/ Z 912718)
- 4) Insert the glue (Z911737)
- 5) Slide in the corner braket

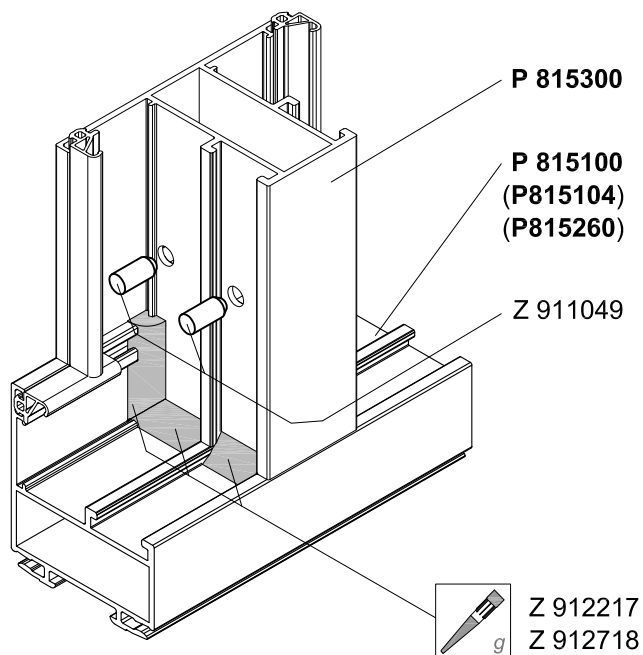

### Processing steps

see like frame

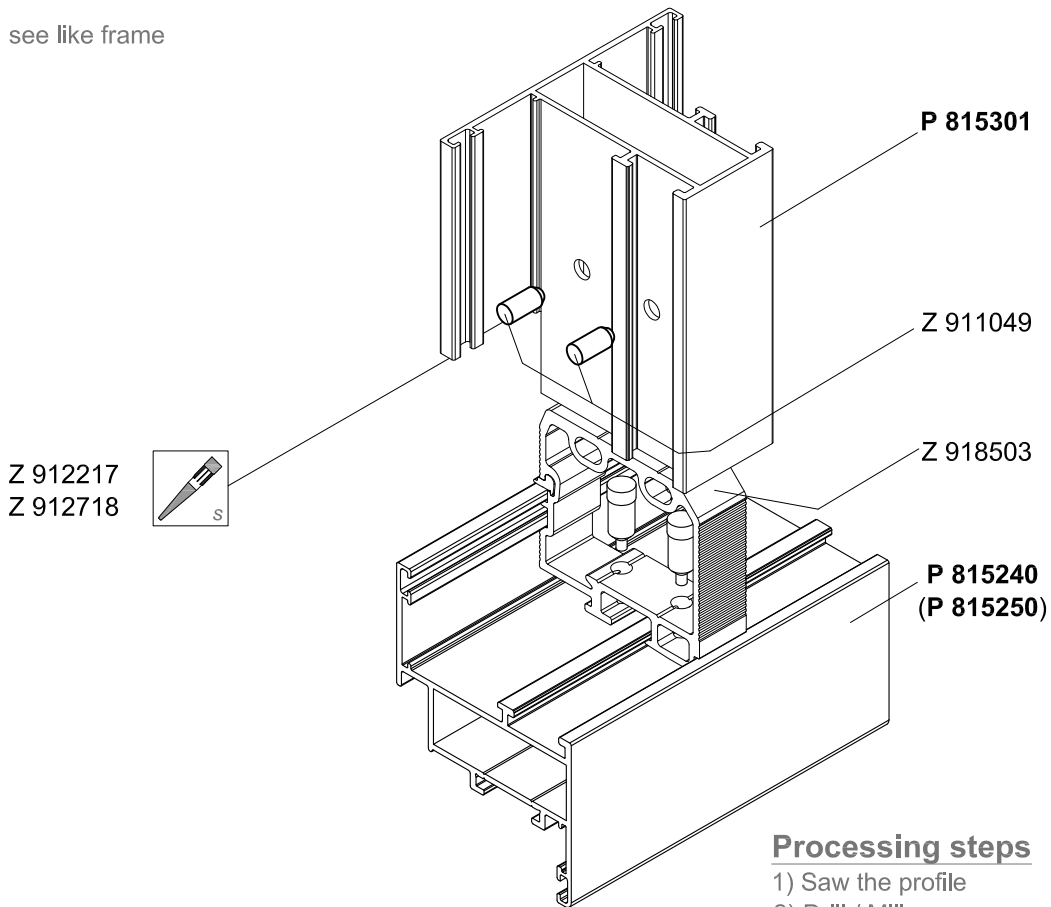

### Processing steps

- 1) Saw the profile
- 2) Drill / Mill
- 3) Seal the cut surface (z 912717/ Z 912718)
- 4) Insert the glue (Z911737)
- 5) Slide in the corner braket

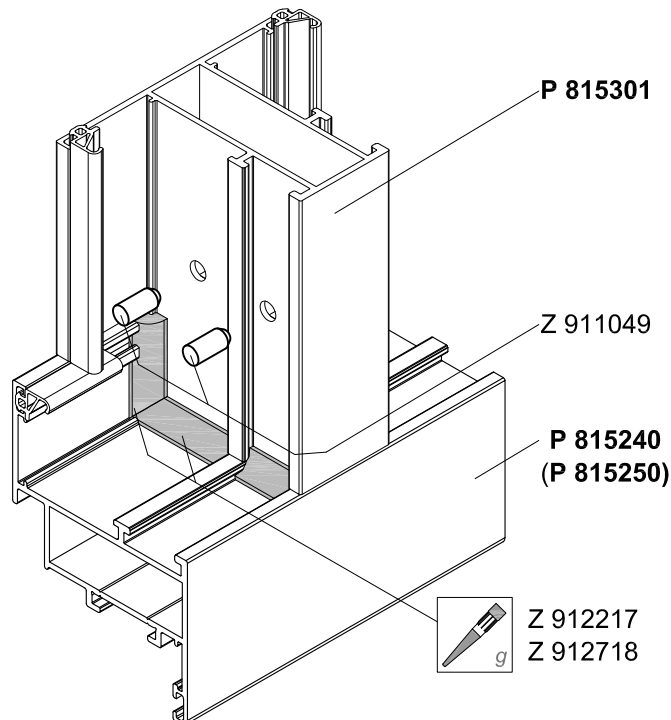



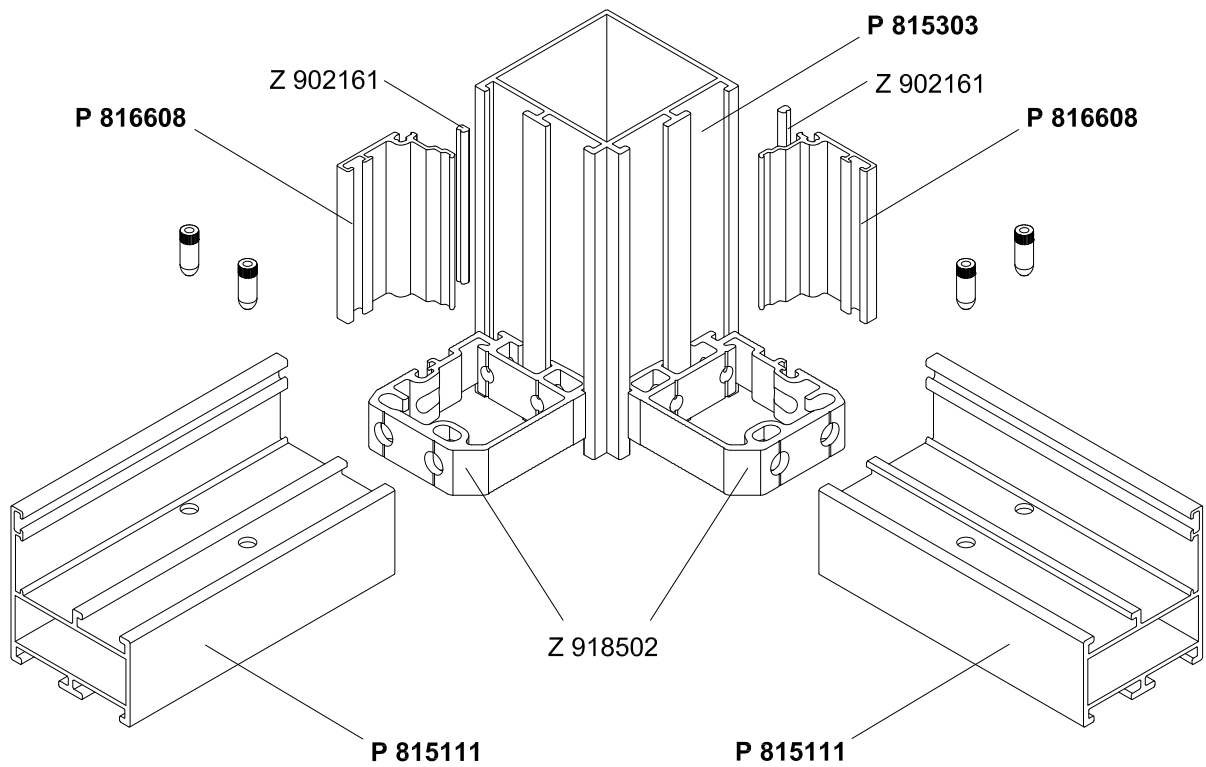

### Processing steps

- 1) Saw the profile
- 2) Drill / Mill
- 3) Insert the glue (Z911737)
- 4) Slide in the corner bracket

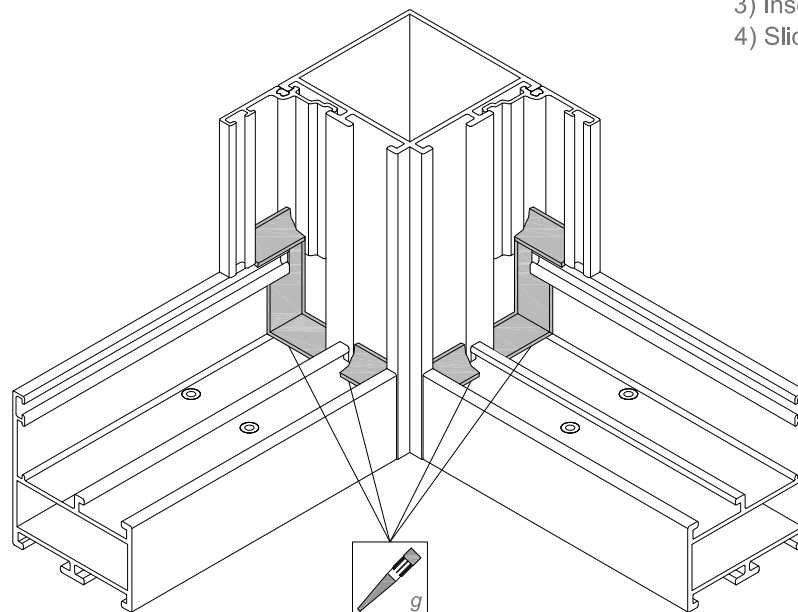

Z 912217  
Z 912718

189003500

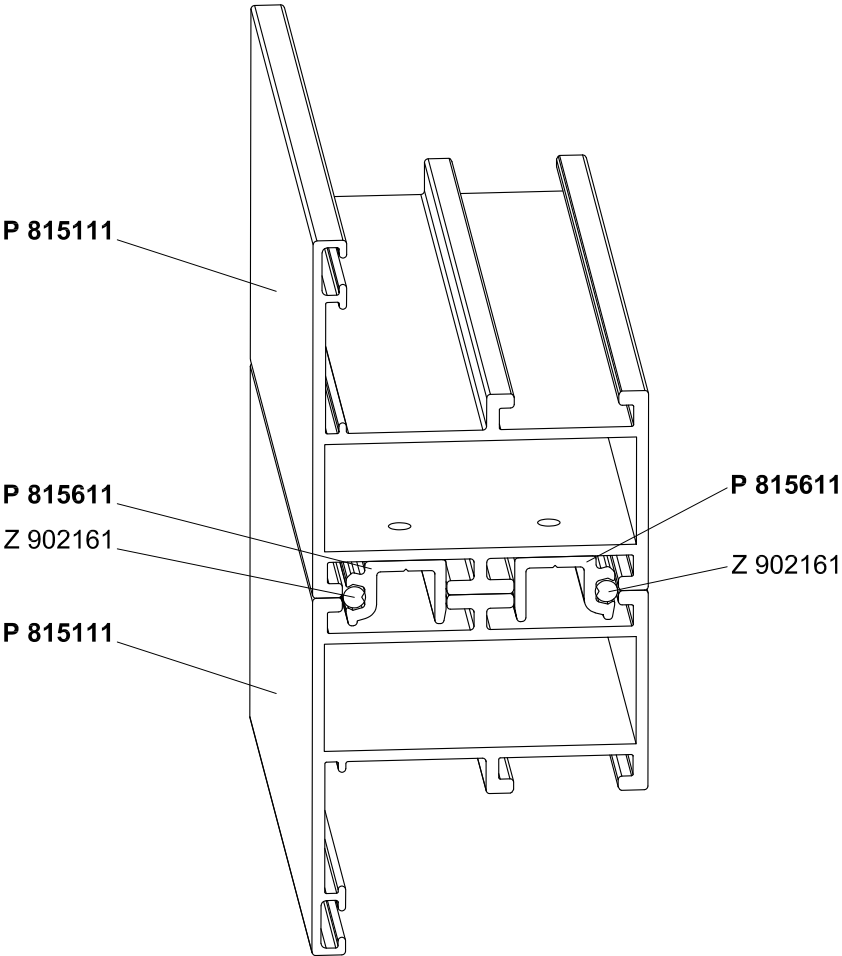
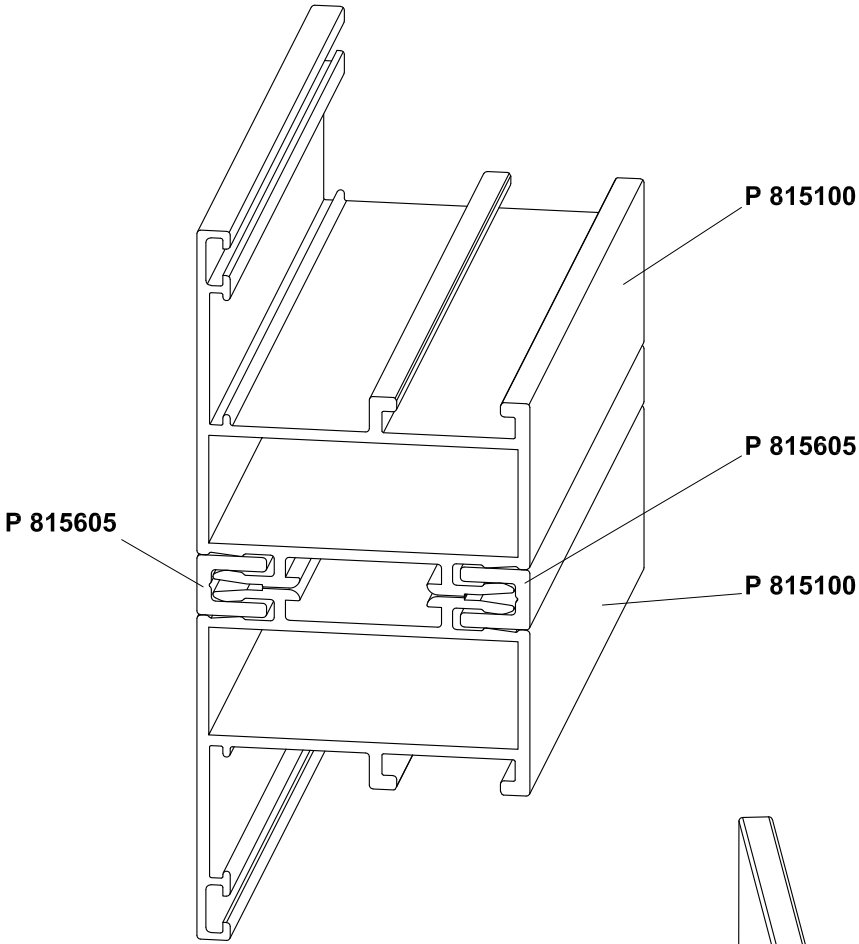

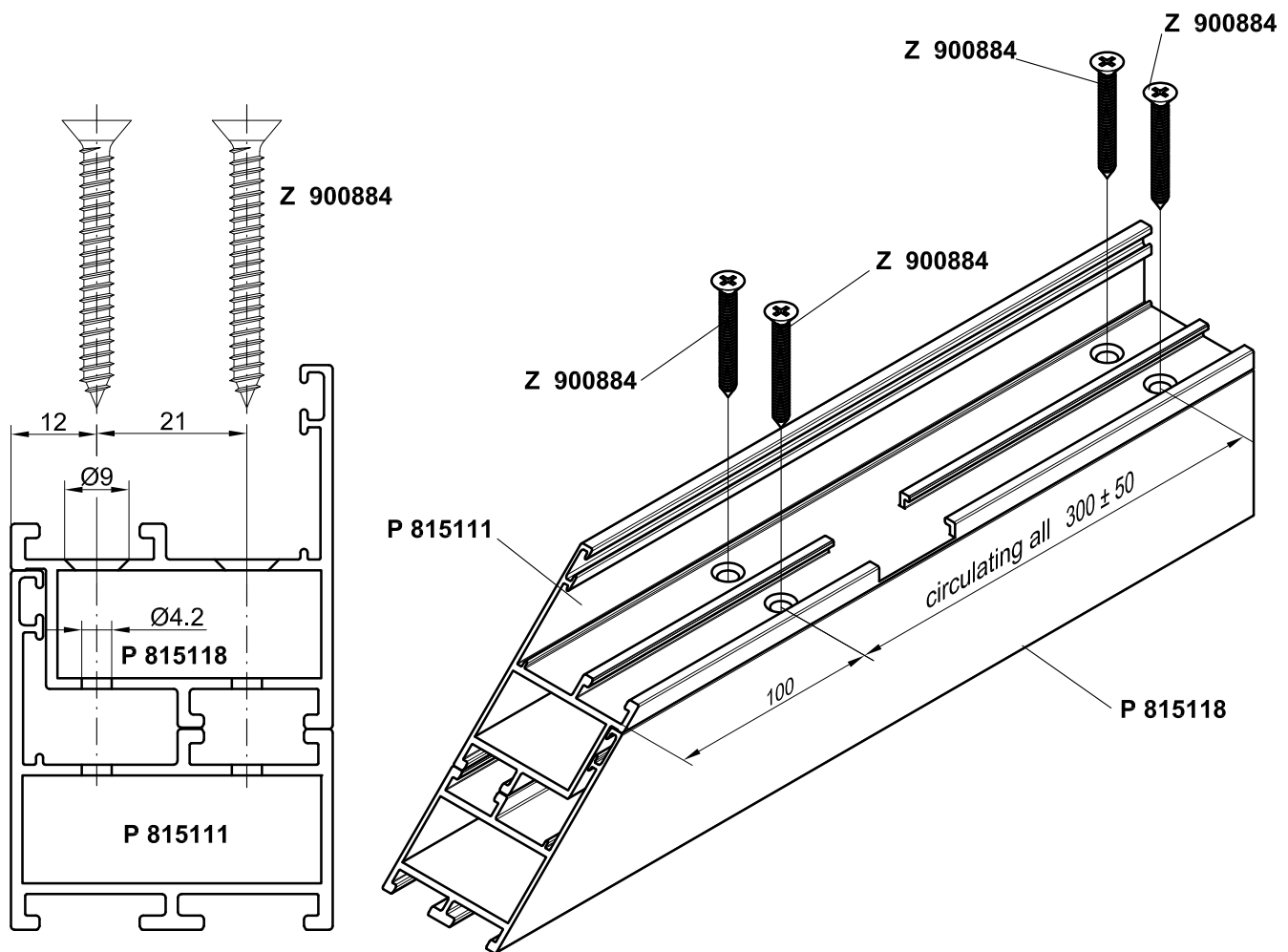

191003700



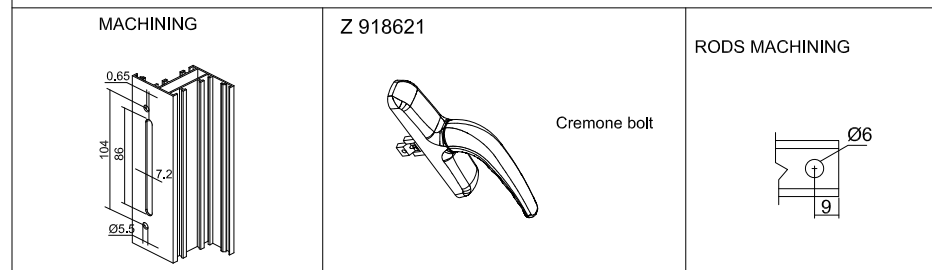
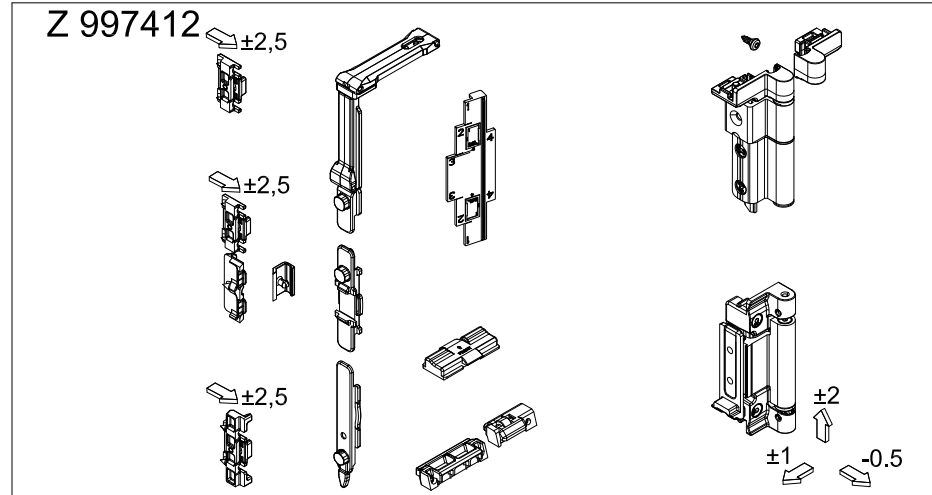

Certified according to European Standard UNI EN 13126-1:2006 / 13126-8:2006

1550x1400	4	160	0	1	4	-	8	-
Test size	Durability	Mass	Fire resistance	Safety in use	Corrosion resistance	Security	Applicable part	Category of use

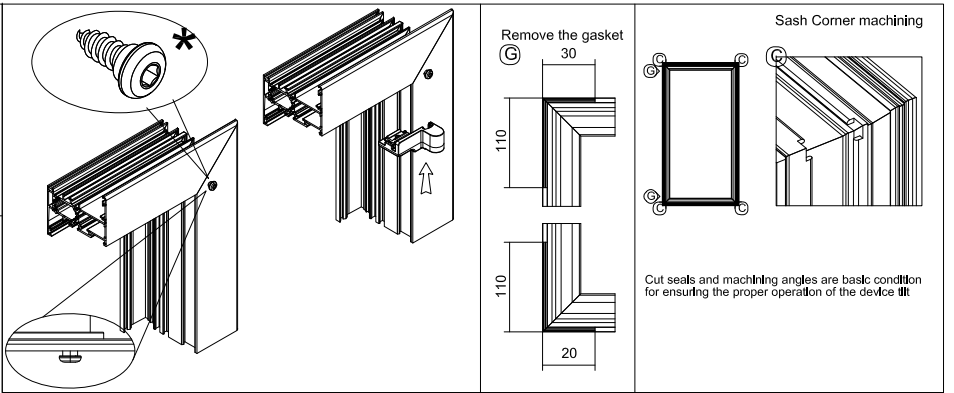
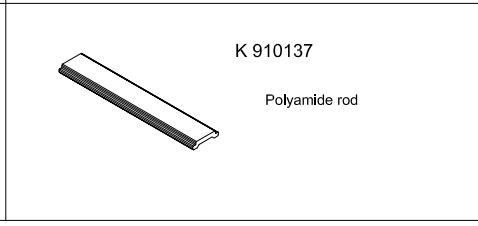
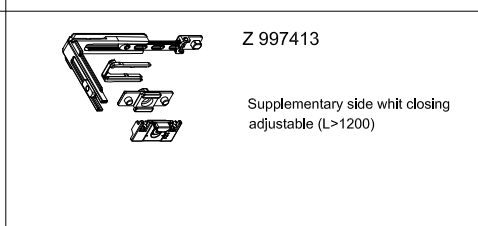
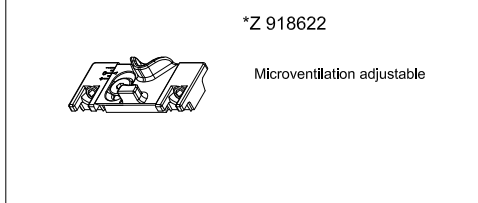
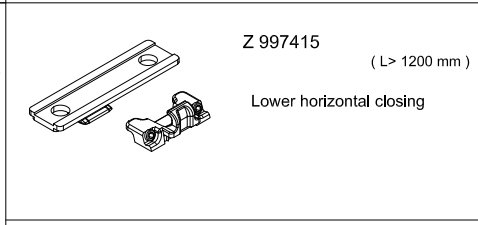
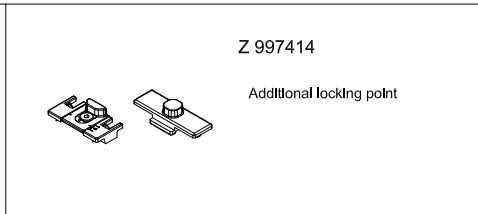
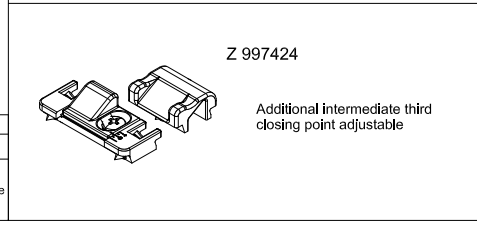
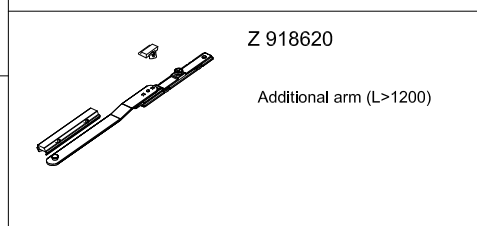
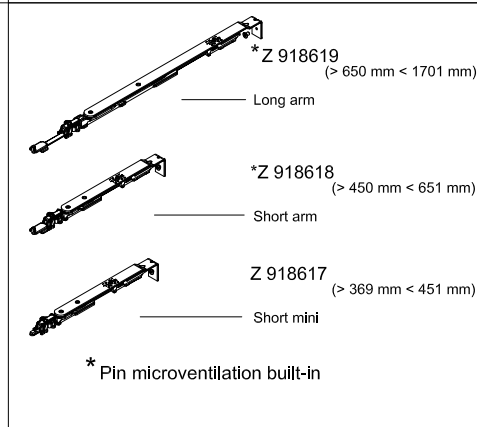
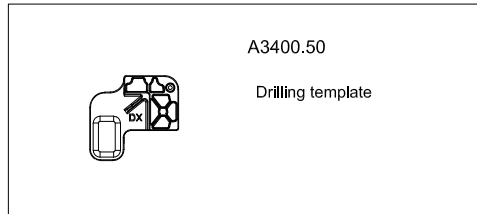

Leaf max weight 160Kg

	2400	2300	2200	2100	2000	1900	1800	1700	1600	1500	1400	1300	1200	1100	1000	900	800	700	600	500	400	370
50	50	50	50	50	50	50	50	50	50	50	50	50	50	50	50	50	50	50	50	50	50	50
44	46	48	42	44	47	49	42	45	48	44	48	50	49	48	46	44	44	44	44	44	44	44
37	39	40	36	38	40	42	37	39	42	40	42	44	40	42	41	40	40	40	40	40	40	40
32	33	35	32	33	35	37	33	35	37	36	38	41	36	38	37	36	36	36	36	36	36	36
28	29	30	28	28	30	31	30	31	33	30	32	35	29	31	30	30	30	30	30	30	30	30
25	26	27	25	25	27	28	27	28	30	27	29	32	25	27	26	26	26	26	26	26	26	26
22	23	24	22	22	24	25	24	25	27	24	26	29	22	24	23	23	23	23	23	23	23	23
20	21	22	20	20	22	23	22	23	25	22	24	27	20	22	21	21	21	21	21	21	21	21
19	19	20	19	19	21	22	20	21	23	20	22	25	19	21	20	20	20	20	20	20	20	20
17	18	19	17	17	19	20	17	18	20	17	19	22	17	19	18	18	18	18	18	18	18	18
16	17	18	16	16	18	19	16	17	19	16	18	21	16	18	17	17	17	17	17	17	17	17
X	X	X	X	X	X	X	X	X	X	X	X	X	X	X	X	X	X	X	X	X	X	X
H	L																					

20 Sash size executable with Max glass thickness 20 mm X Not feasible  
Application Field Leaf max weight 160 Kg \*For Leafweight >100 kg SCREW FIXING REQUIRED Glass thickness Max without air space

Configurations

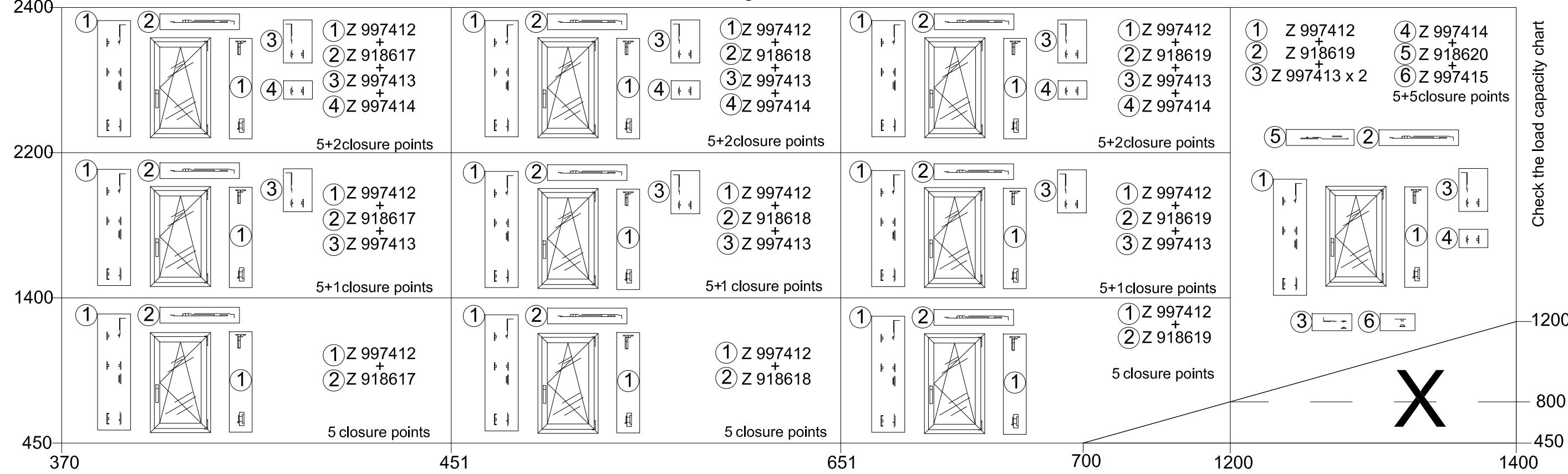

# FRAME

A3400.50

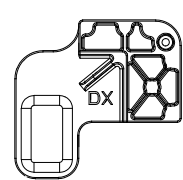

Drilling template

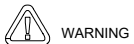
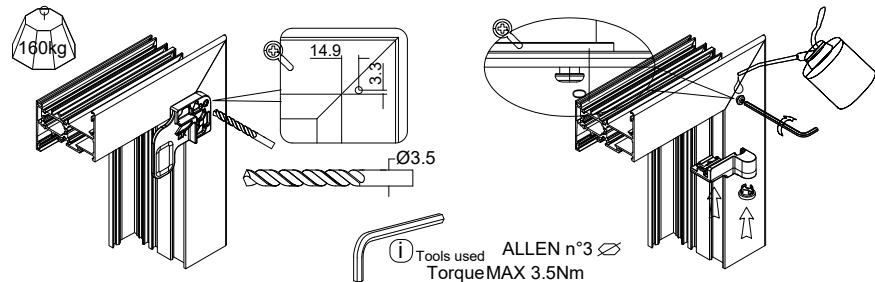

WARNING

NOT OBLIGATORY FOR WEIGHT ≤100kg

Tools used ALLEN n°3 TorqueMAX 3.5Nm

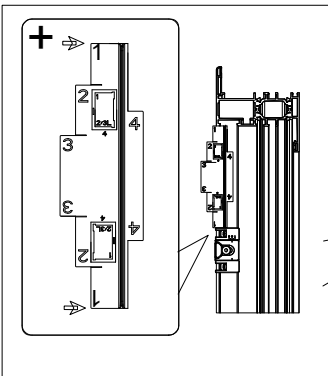

Z 918622  
Microventilation optional

\* Z 918618 = 286

\* Z 918619 = 476

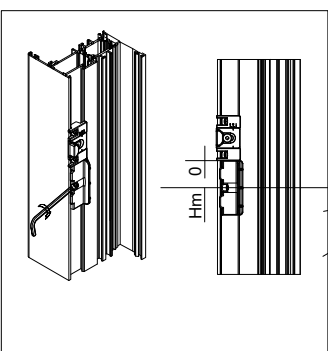

Hm

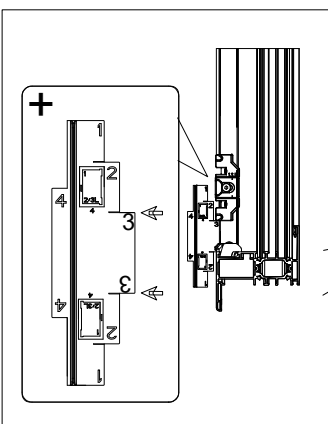

+2.5 0 -2.5

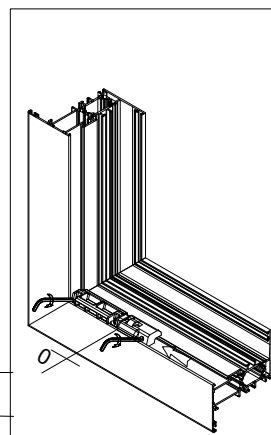
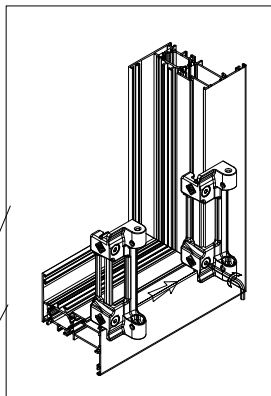
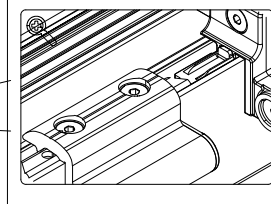
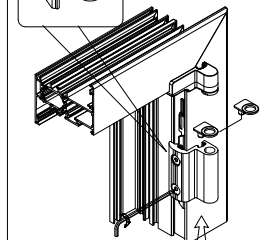
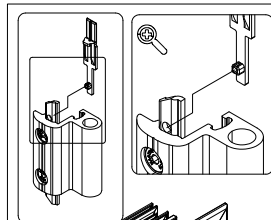
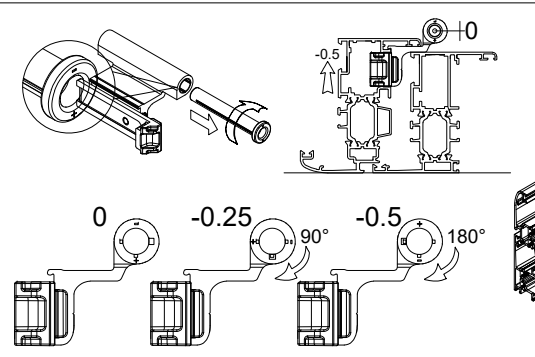
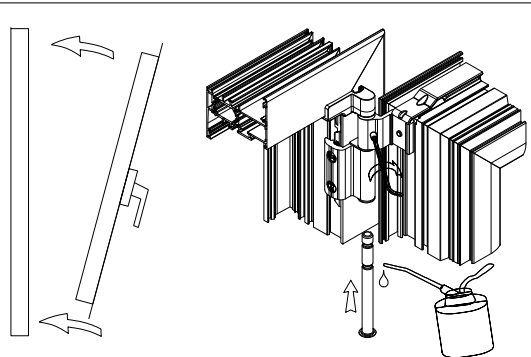
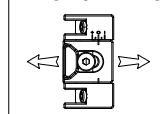

# SASH

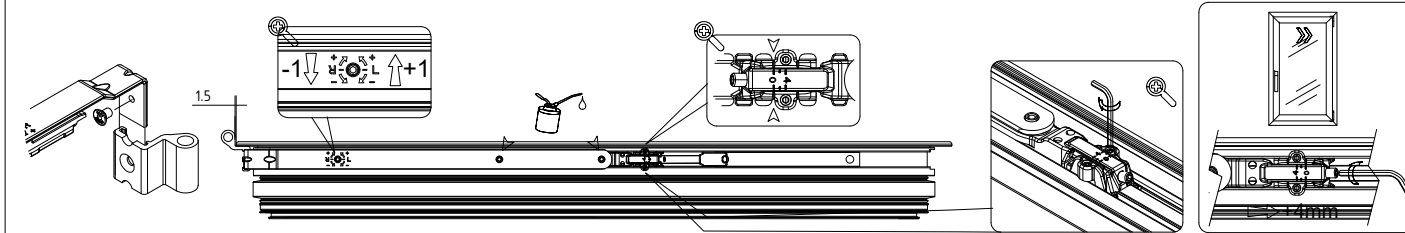

Z 918619

Z 918620 Optional

L-690

L-339

Z 918617

L-355

\*Z 918618

L-541

\*Z 918619

Z 997413 H>1400mm

H/2-166

Z-166

Z

H

Y

Y-132

L

Z 997413 / Z 997415 L>1200mm

L/2-132

IT IS RECOMMENDED TO USE A LIMITER ARM FOR WINDOWS WIDTH >500 AND FOR WINDOWS WITH 180° RESTRICTED OPENING

Z 997446  
6"

Z 997447  
8"

Z 997448  
10"

NO 180°

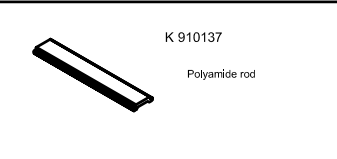
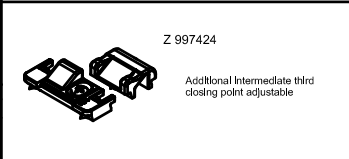
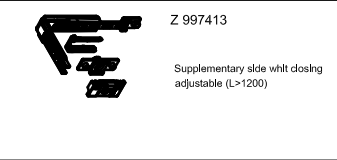
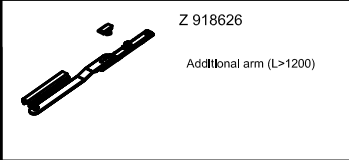
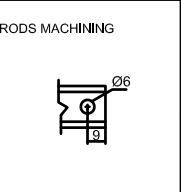
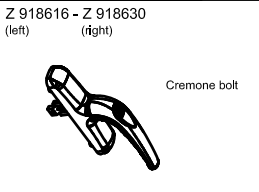
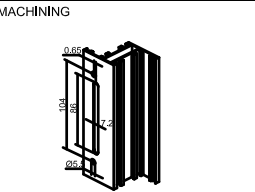
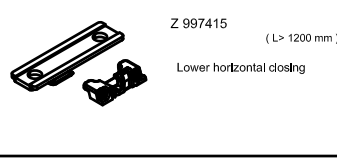
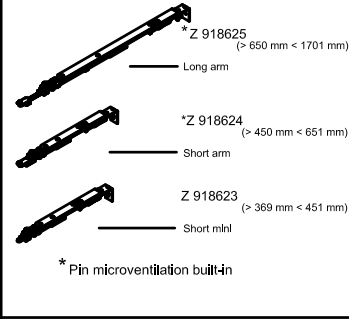
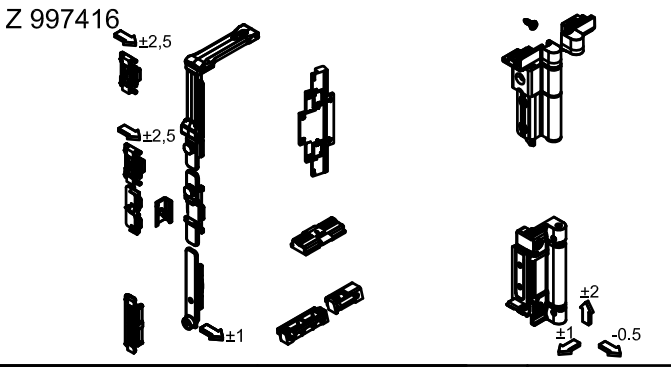
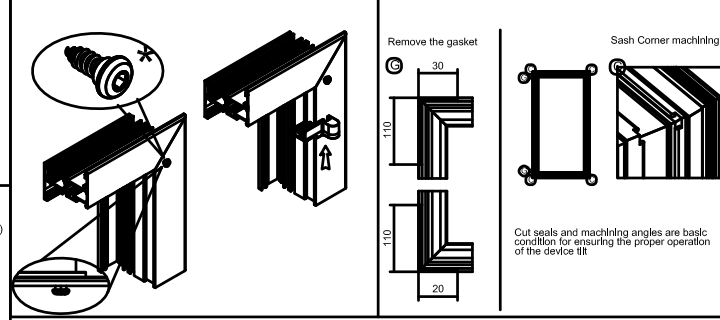

Leaf max weight 160Kg

2400	50	50	44	37	32	28	25	22	20	19	17	16	
2300	50	50	46	39	33	29	26	23	21	19	18	17	
2200	50	50	48	40	35	30	27	24	22	20	19	17	
2100	50	50	50	42	36	32	28	25	23	21	20	18	
2000	50	50	50	44	38	33	30	27	24	22	21	19	
1900	50	50	50	47	40	35	31	28	26	23	22	20	
1800	50	50	50	49	42	37	33	30	27	25	23	21	
1700	50	50	50	50	45	39	35	31	29	26	24	20	
1600	50	50	50	50	48	42	37	33	30	28	23	21	
1500	50	50	50	50	50	44	40	36	32	30	25	23	
1400	50	50	50	50	50	48	42	38	35	29	26	24	
1300	50	50	50	50	50	50	46	41	34	31	28	22	
1200	50	50	50	50	50	50	49	40	36	33	26	19	
1100	50	50	50	50	50	50	48	44	40	30	22	X	
1000	50	50	50	50	50	50	50	48	36	27	X	X	
900	50	50	50	50	50	50	50	36	32	X	X	X	
800	50	50	50	50	50	50	44	40	X	X	X	X	
700	50	50	50	50	50	50	50	X	X	X	X	X	
600	50	50	50	50	50	44	X	X	X	X	X	X	
450	50	50	50	50	50	X	X	X	X	X	X	X	
H	L	370	400	500	600	700	800	900	1000	1100	1200	1300	1400

20 Sash size executable with Max glass thickness 20 mm  Not feasible

Application Field  
 Leaf max weight 160 Kg  
 \*For Leaf weight > 100 kg SCREW FIXING REQUIRED  
 Glass thickness Max without air space

Certified according to European Standard UNI EN 13126-1:2006 / 13126-2:2006

1550x1400	4	160	0	1	4	-	8	-
Test size	Durability	Mass	Fire resistance	Safety in use	Corrosion resistance	Security	Applicable part	Category of use

**Configurations**

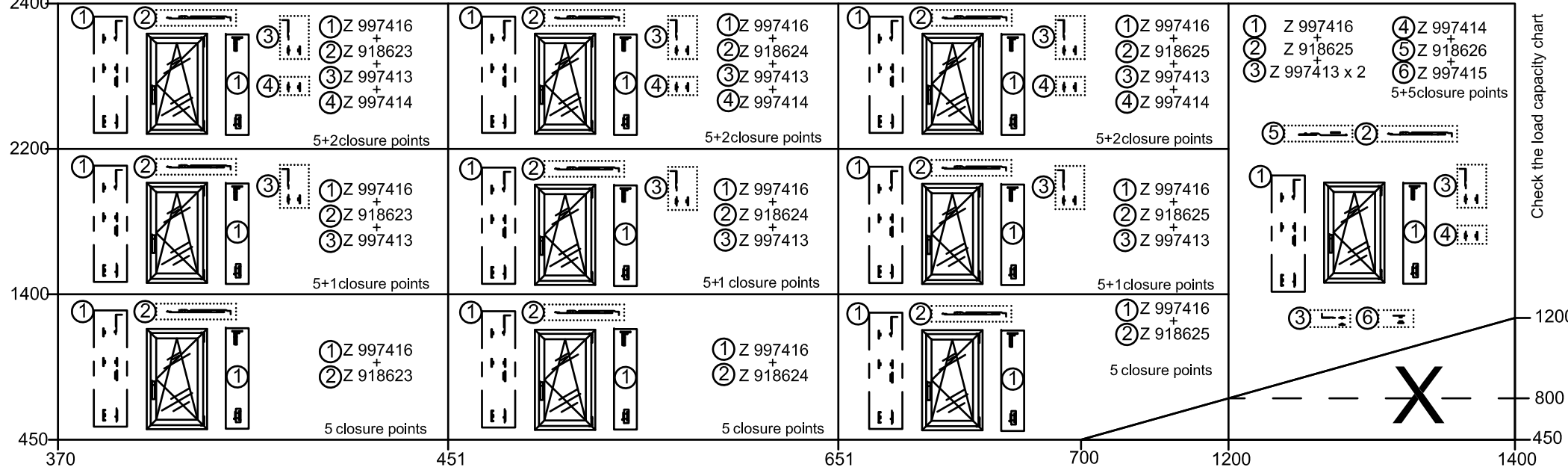

Check the load capacity chart



# FRAME

A3400.50

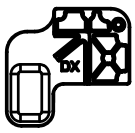

Drilling template

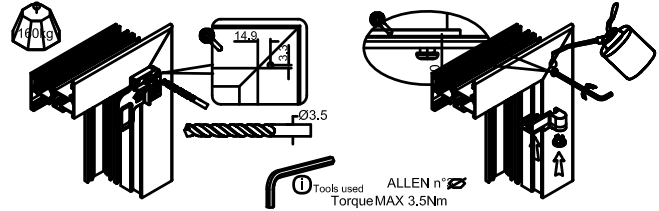

Tools used ALLEN n° Torque MAX 3.5Nm

WARNING NOT OBLIGATORY FOR WEIGHT  $\leq 100\text{kg}$

Z 918622 Microventilation optional

\*Z 918624 = 286  
\*Z 918625 = 476

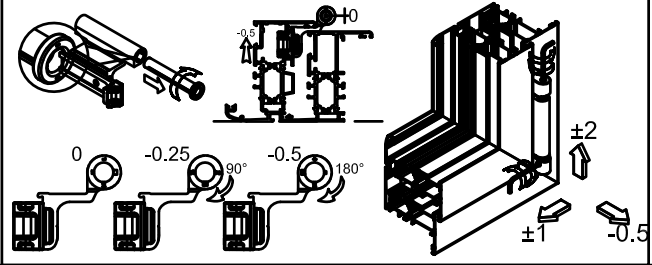
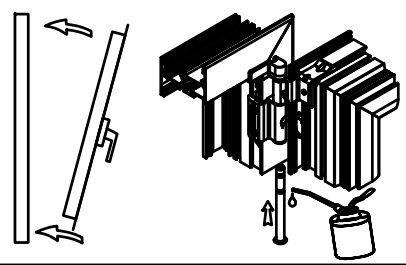
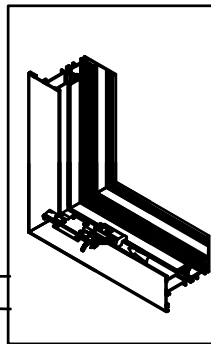
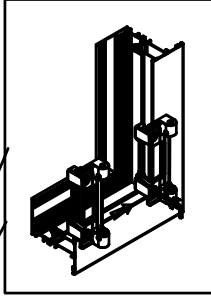
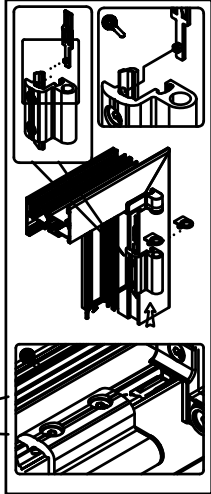
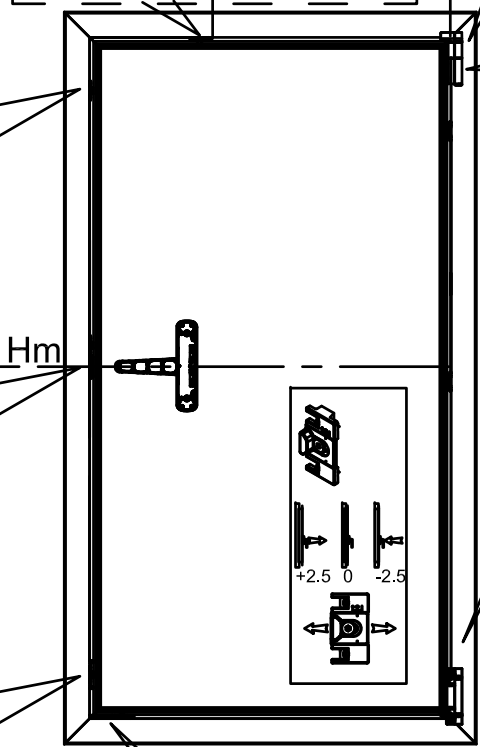
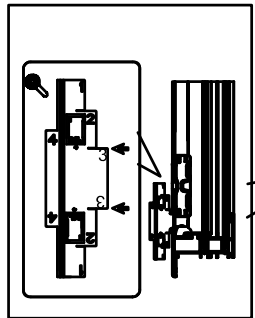
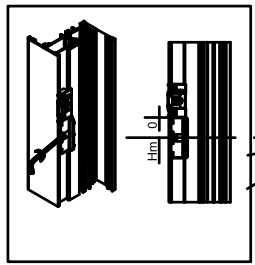
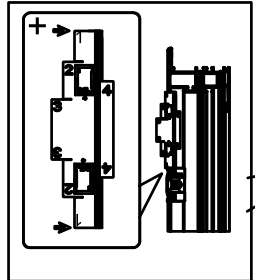

# SASH

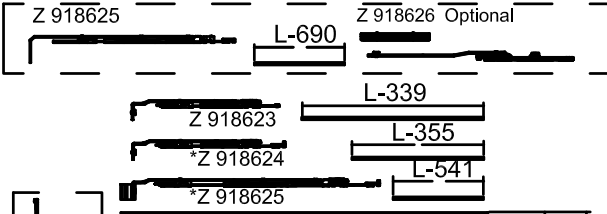
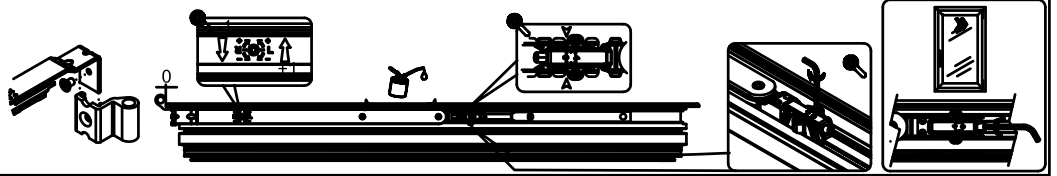

Z 997413  $H > 1400\text{mm}$

H/2-166

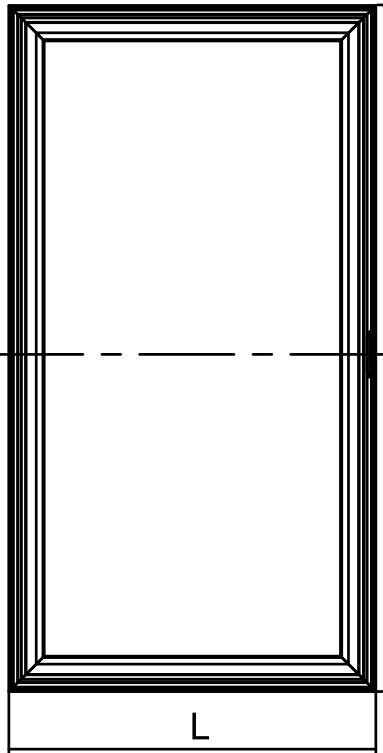

Z

Y

H

L

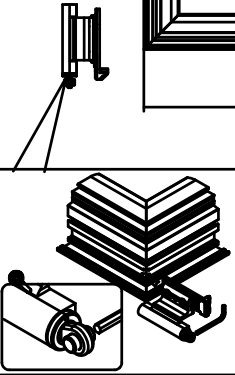
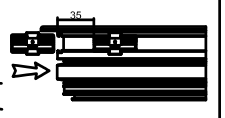
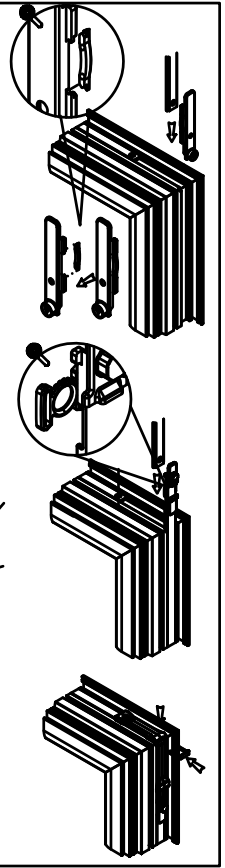
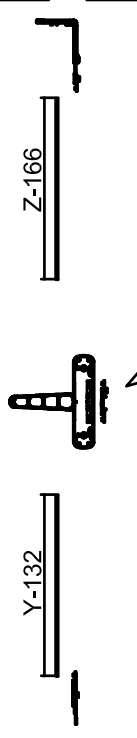

Z 997413 / Z 997415  $L > 1200\text{mm}$

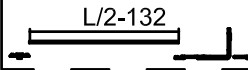

IT IS RECOMMENDED TO USE A LIMITER ARM FOR WINDOWS WIDTH  $> 500$  AND FOR WINDOWS WITH  $180^\circ$  RESTRICTED OPENING

Z 997446 6" Z 997447 8" Z 997448 10"

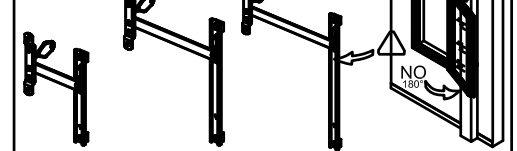



Lambda 45 NI

turn opening inside

(Solution A)

Hing for turn opening inside - Z 997253

FRAME

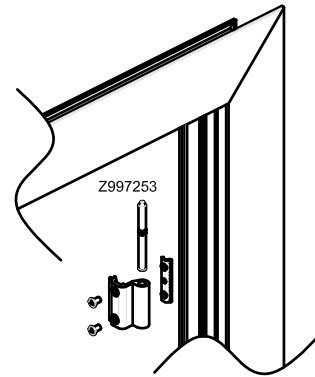

SASH

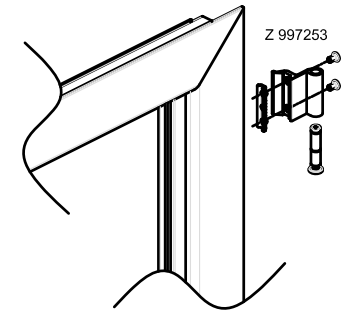

FRAME

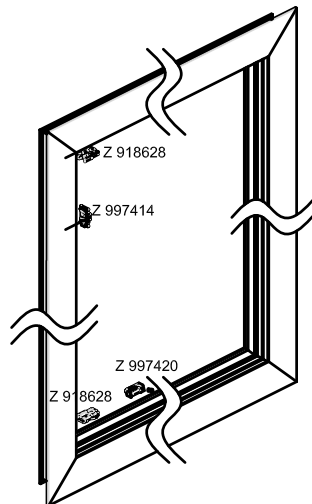
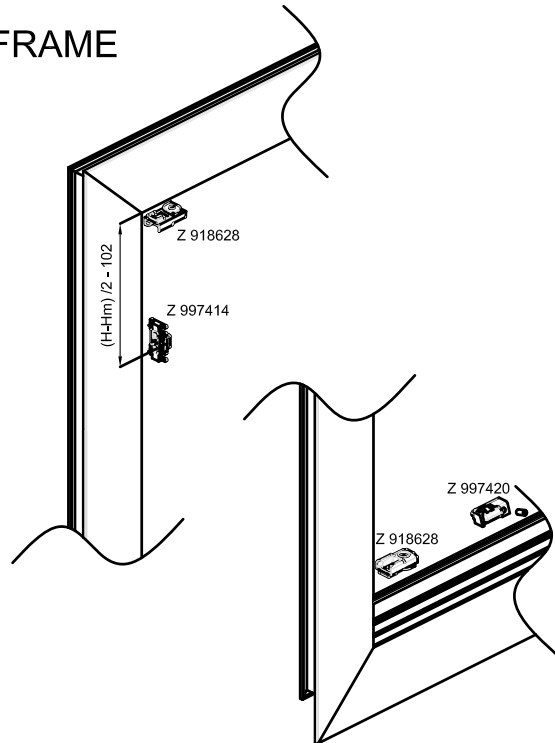

SASH

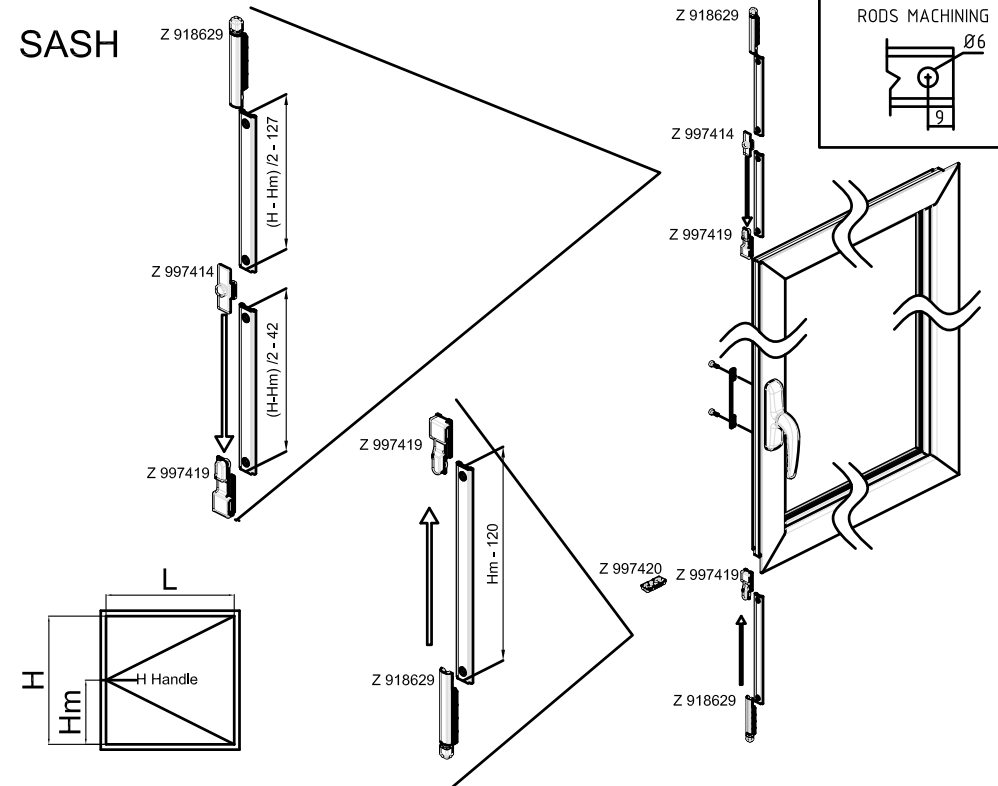



Lambda 45 NI

turn opening inside

(Solution B)

Hing for turn opening inside - Z 997422

 **WARNING**   
 NOT OBLIGATORY FOR WEIGHT ≤100kg

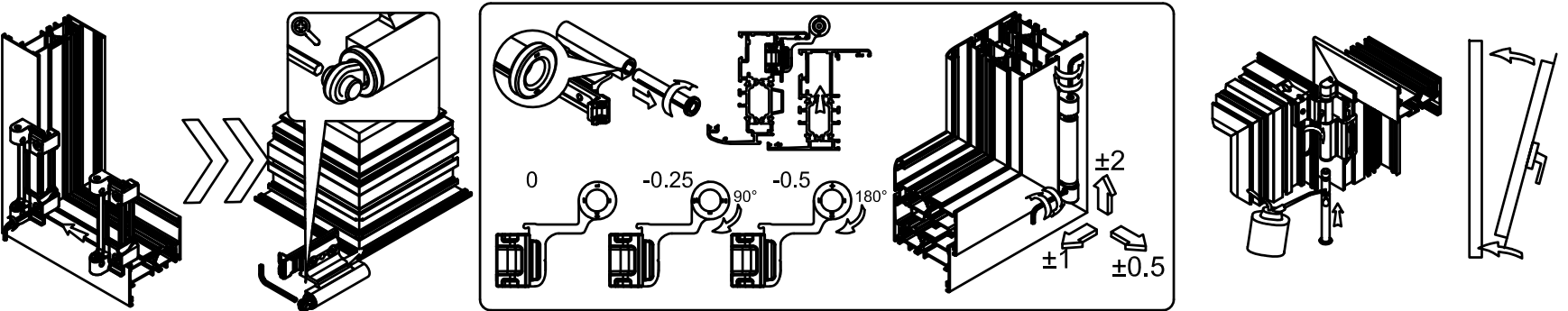
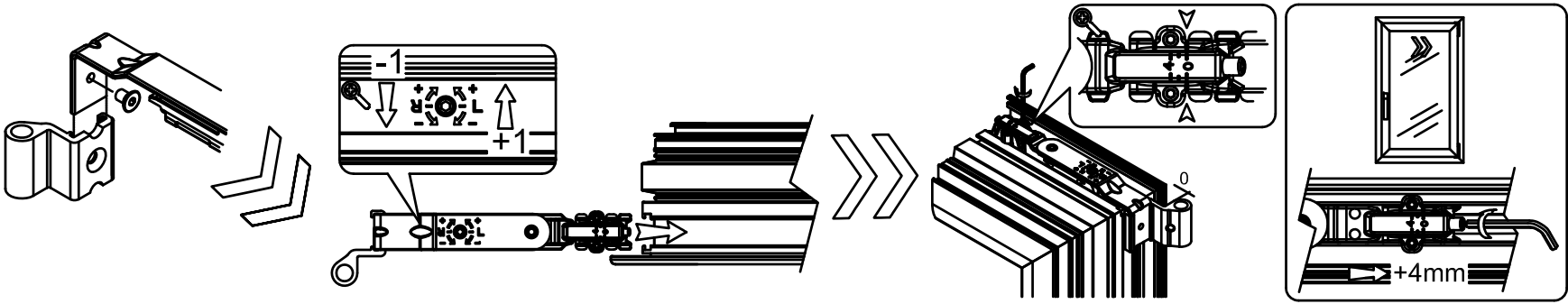
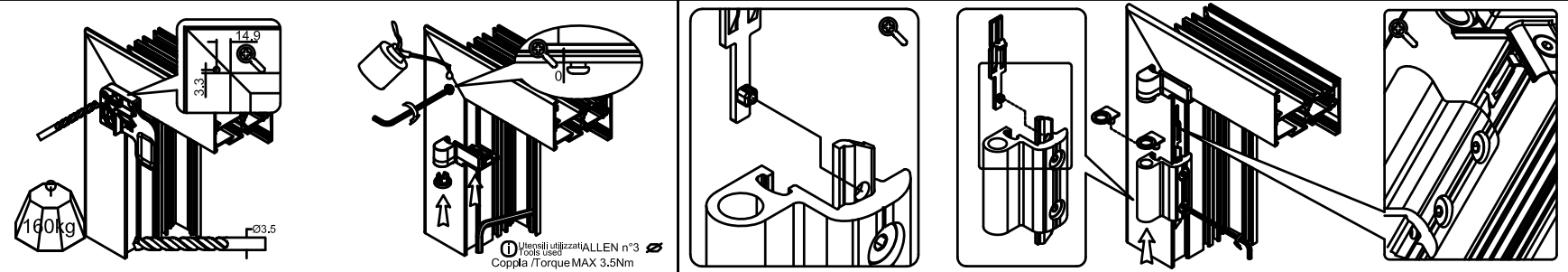
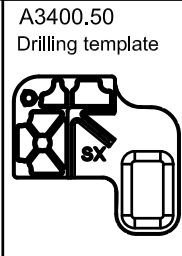

FRAME

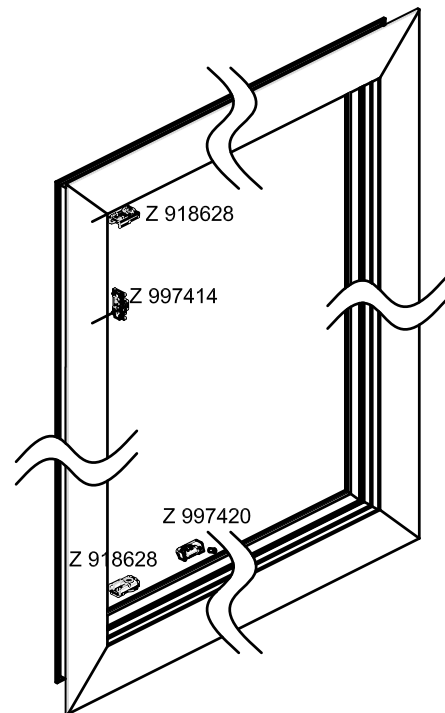
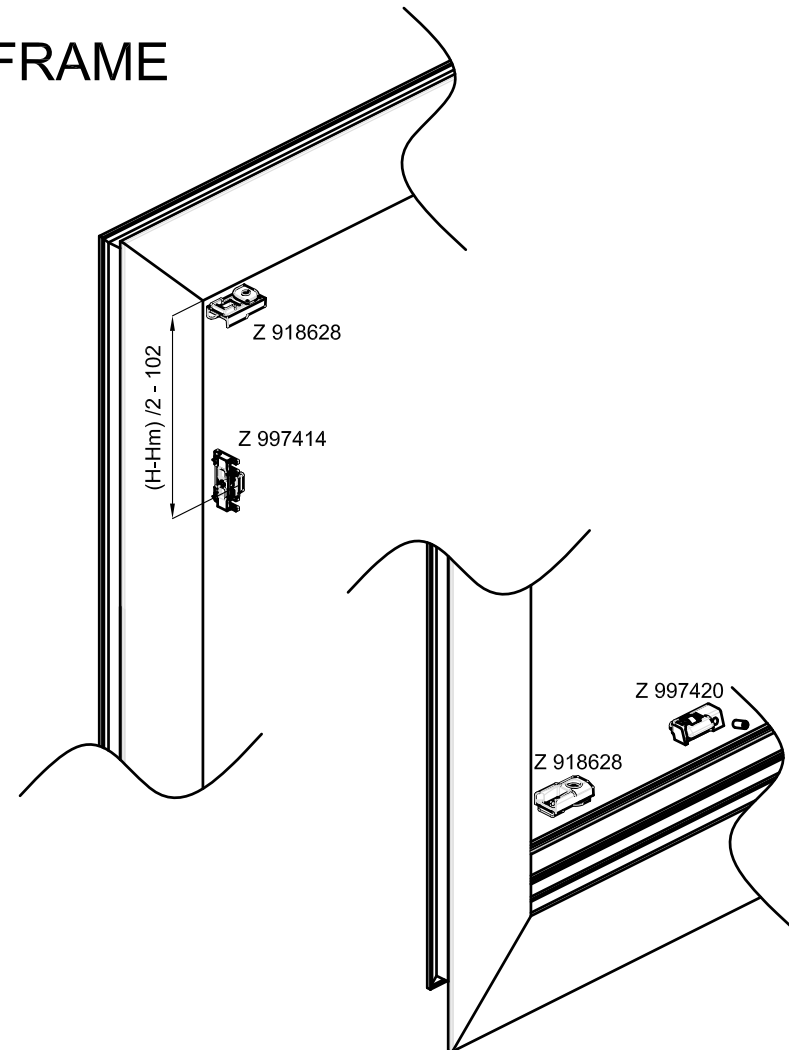

SASH

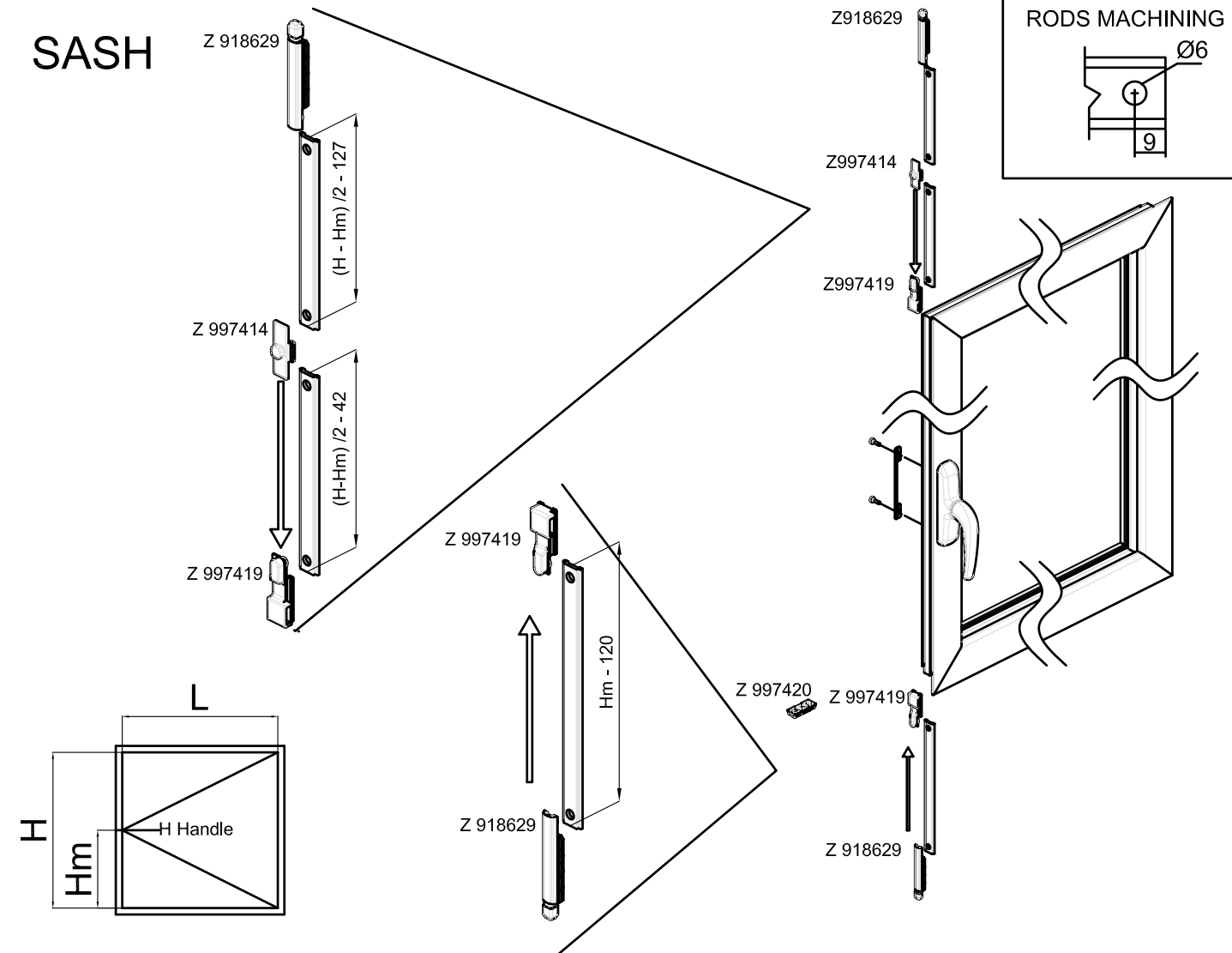



2 Part	120Kg	160Kg
Z 997425	100%	
3 Part	120Kg	160Kg
Z 997426		100%

Lambda 45 NI  
 door hardware

H	B	2600	100%	100%	100%	100%	100%	100%	100%	C	
		2500	100%	100%	100%	100%	100%	100%	100%		
		2400	100%	100%	100%	100%	100%	100%	100%		
	A	2300	100%	100%	100%	100%	100%	100%	100%		77%
		2200	100%	100%	100%	100%	100%	100%	83%		69%
		2100	100%	100%	100%	100%	100%	100%	75%		62%
		2000	100%	100%	100%	100%	100%	82%	67%		54%
		1900	100%	100%	100%	100%	100%	73%	58%		50%
		1800	100%	100%	100%	100%	80%	64%	50%		50%
		1700	100%	100%	100%	100%	70%	55%	50%		50%
1600	100%	100%	100%	78%	60%	50%	50%	50%			
		600	700	800	900	1000	1100	1200	1300		
		A							D		
		L									

Hinges

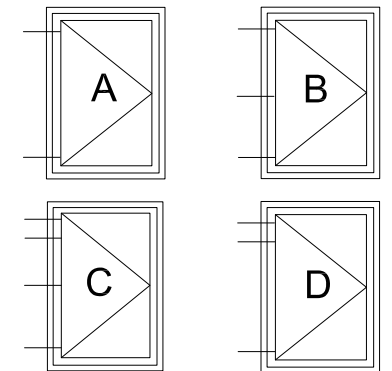

Calculate the sash load capacity in percentage as indicated in the table (according to the dimensions)  
 Example Z 997425 - Sash L1200xH2100:120Kg (100%) x 75/100= 90Kg (A)

2 Part

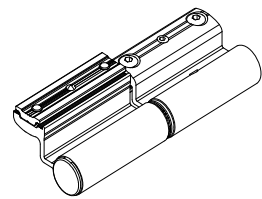

Z 997425

3 Part

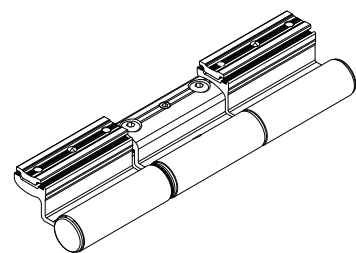

Z 997426

Mounting Indication

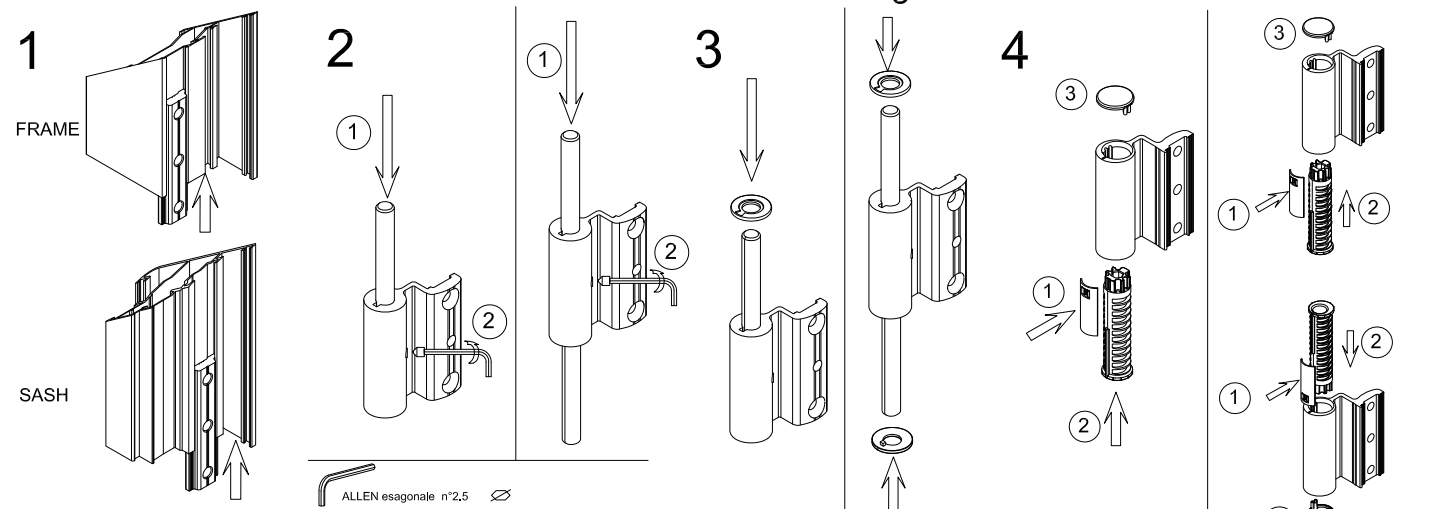

\* NOTE:

With the 3 wings hinge, leave the B wing free, let it slide in the profile and insert it in the pin only once the sash is mounted. Loosen the screws and the setscrew of B wing also for the height adjustment.

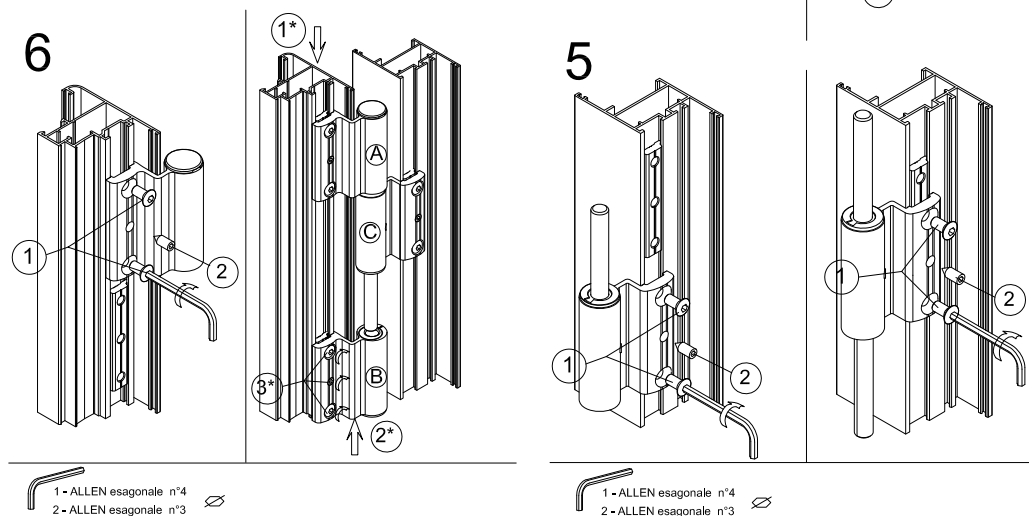

Adjustments

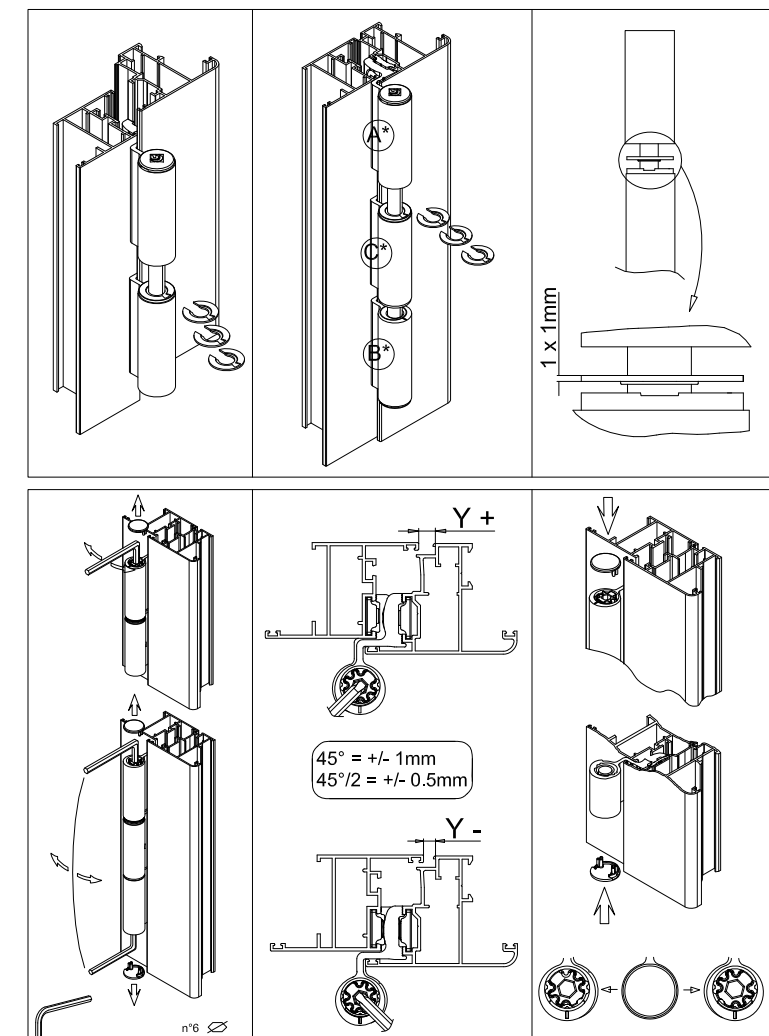

P 815100

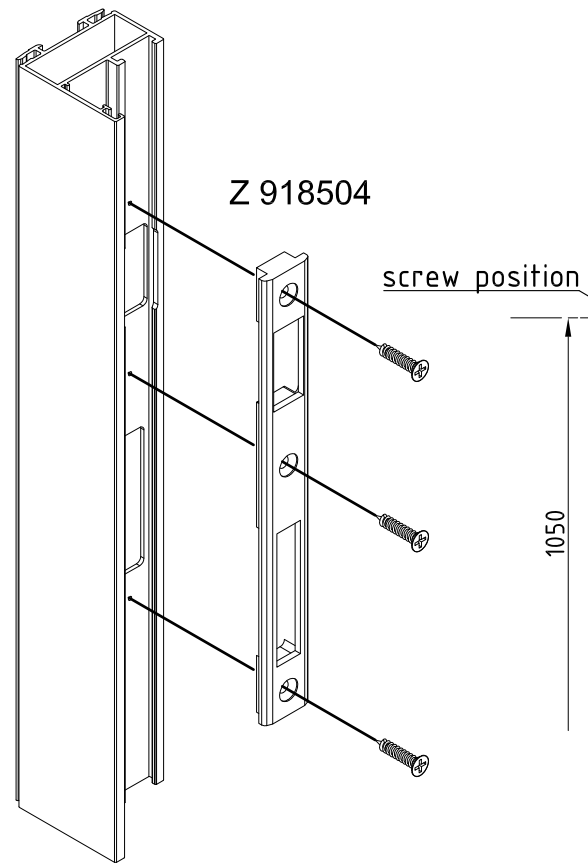

Z 918504

screw position

screw position

screw position

1050

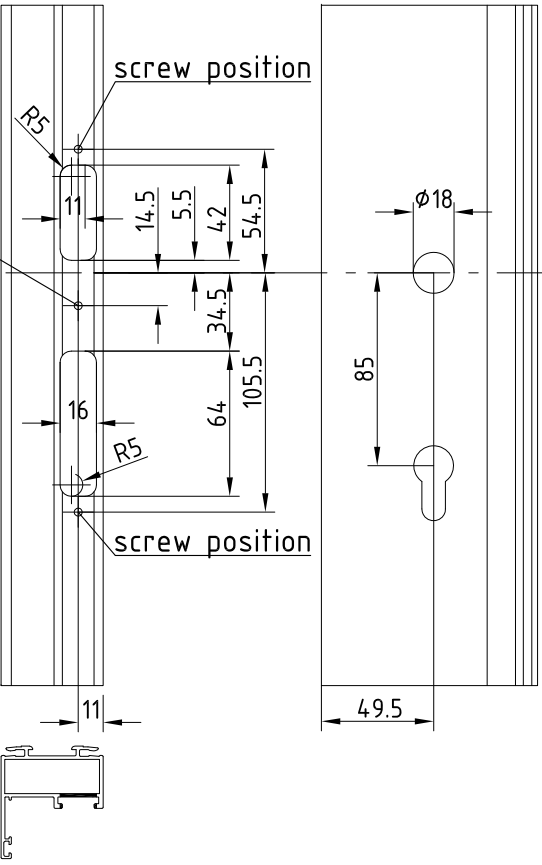

P 815250

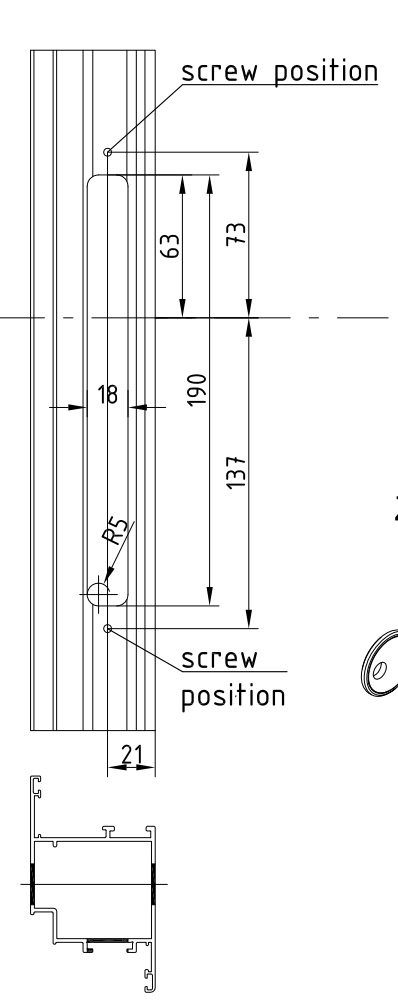

screw position

screw position

Z 918403

Z 918402

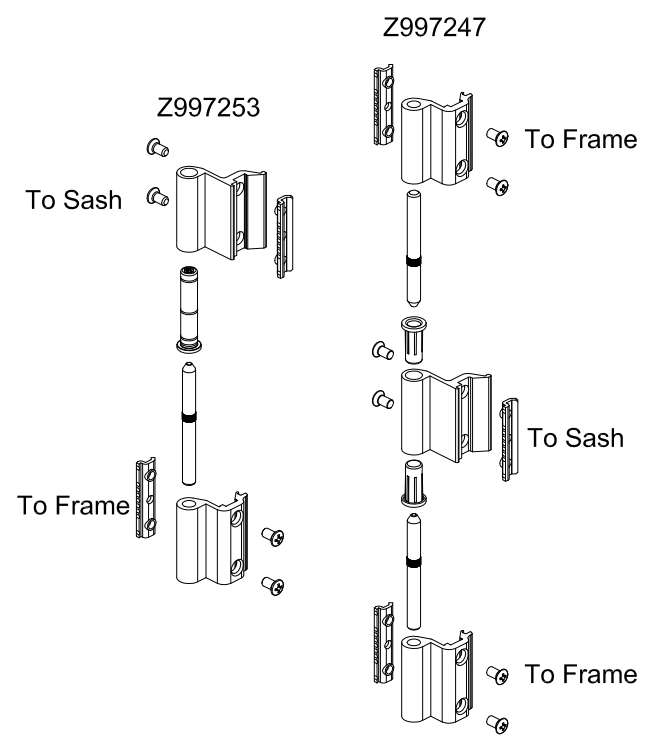
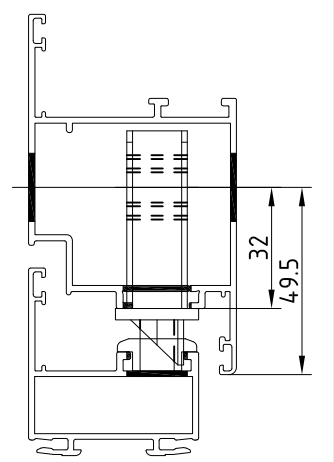
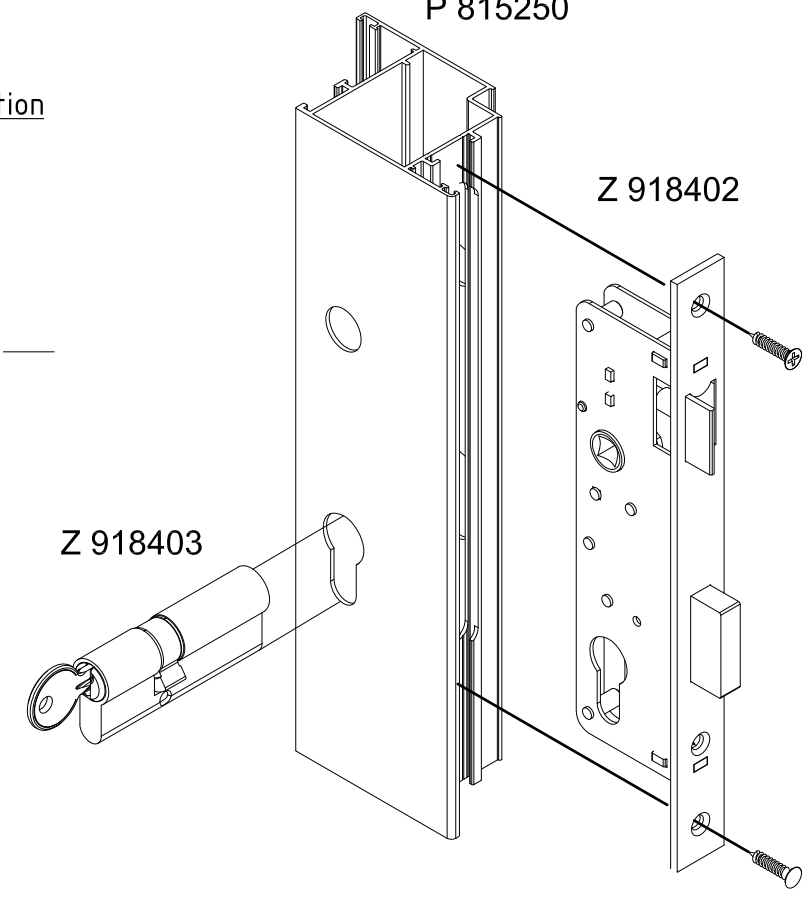

Z 997247

Z 997253

Z 997255

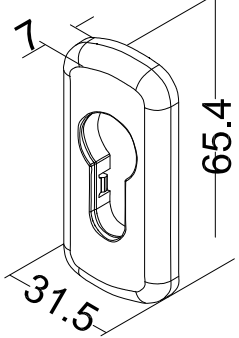

Machining

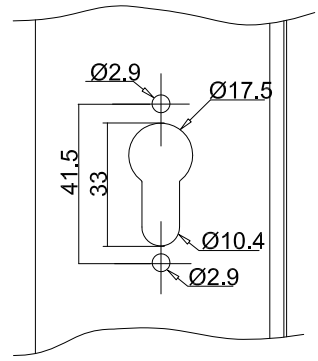

Sequence of assembly and disassembly

Mounting

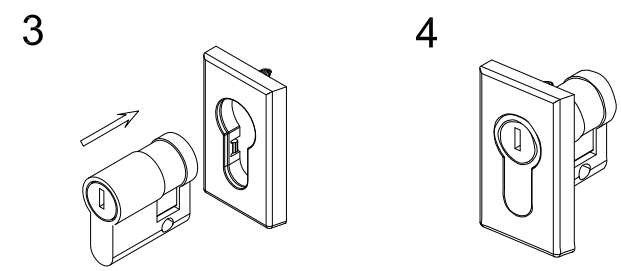
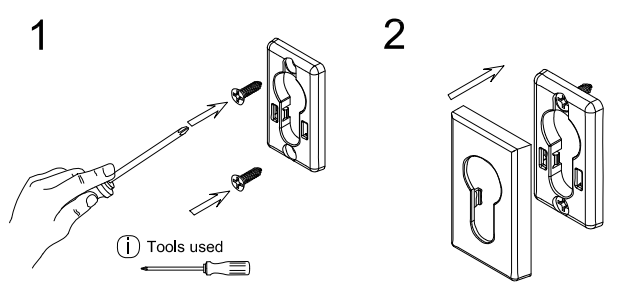

Disassembly

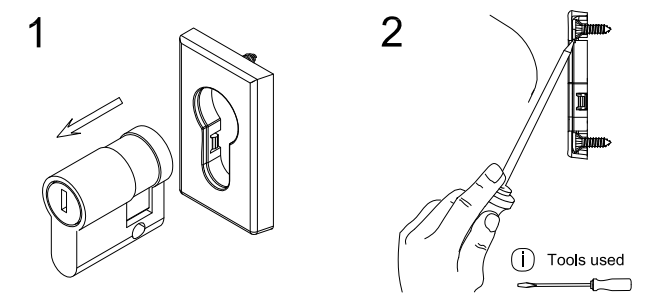

Lambda 45 NI  
 bottom hing opening inside  
 (Solution A)

Z 997249

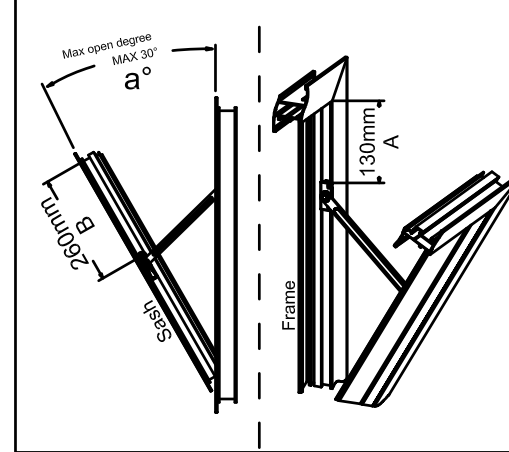

H sash mm	A mm	B mm	a°	Sash weight kg
1.200	130	260	11	53
1.100	130	260	12	49
1.000	130	260	14	44
900	130	260	16	40
800	130	260	19	36
700	130	260	23	31
600	130	260	30	27

Z 997313

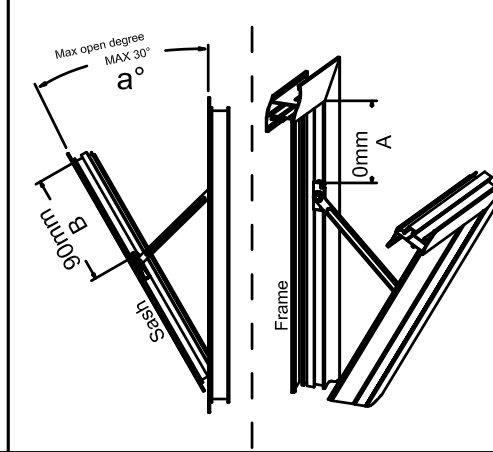

H sash mm	A mm	B mm	a°	Sash weight kg
800	0	90	8	36
700	0	90	9	31
650	0	90	9	29
600	0	90	10	27
550	0	90	11	25
500	0	90	13	23
450	0	90	15	20
400	0	90	17	18
350	0	90	20	16
300	0	90	25	14
260	0	90	30	12

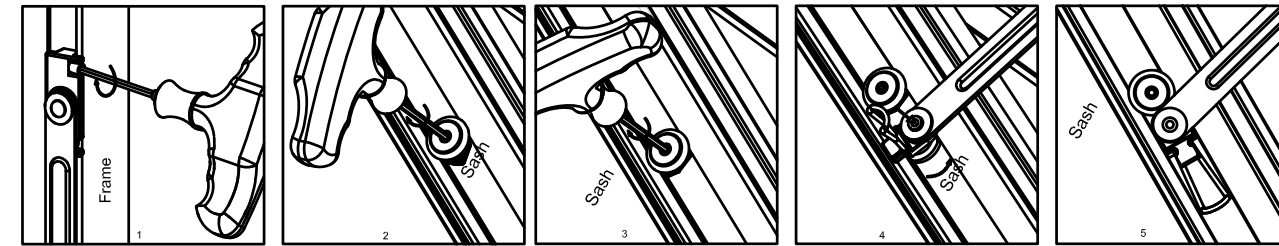

Z 997428

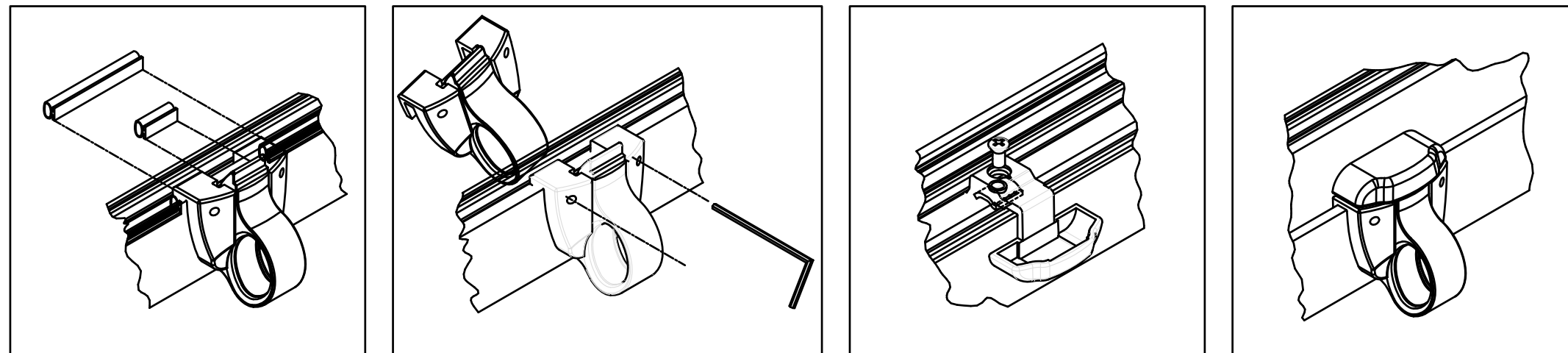

Z 997417

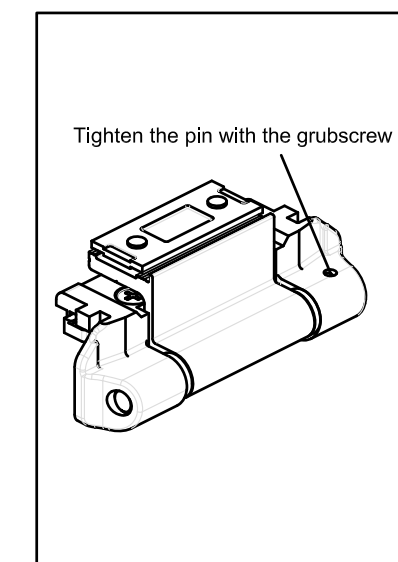
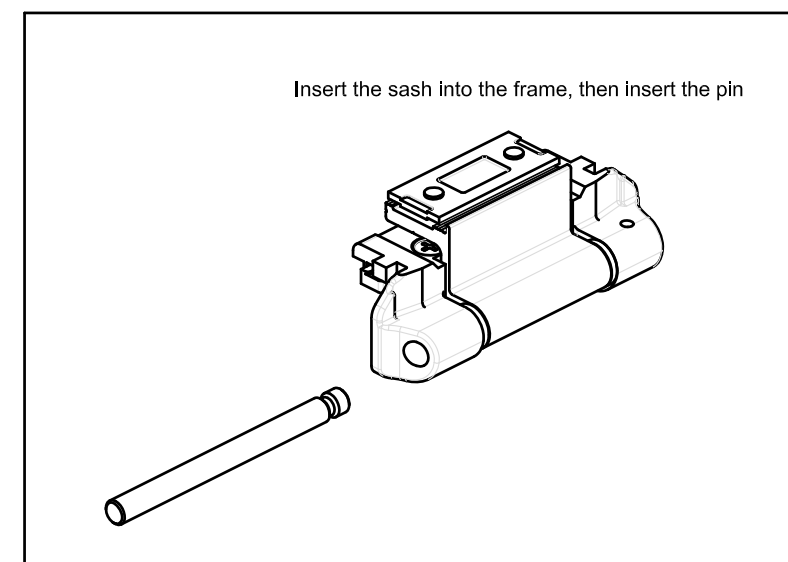
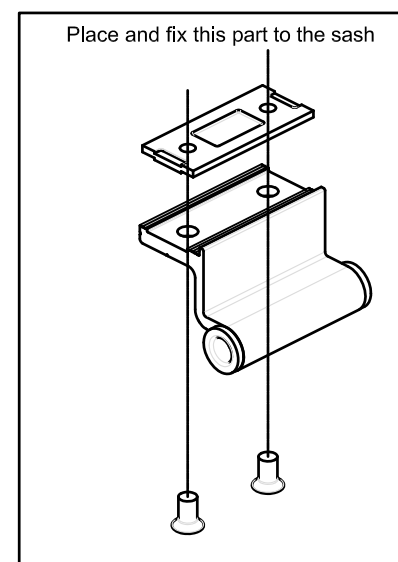
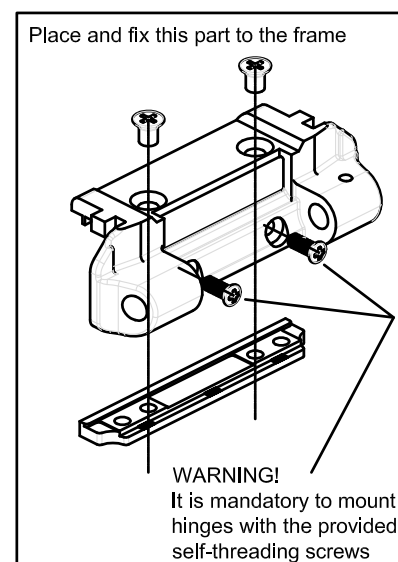





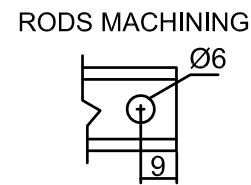

Lambda 45 NI  
 bottom hing opening inside  
 (Solution B)

SASH  
 1)

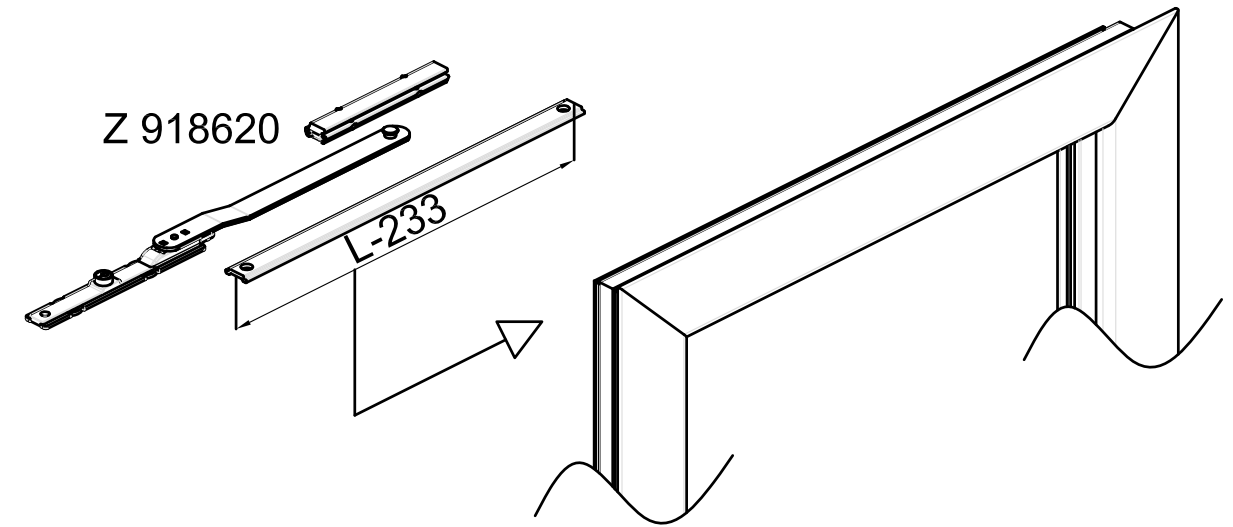

SASH  
 2)

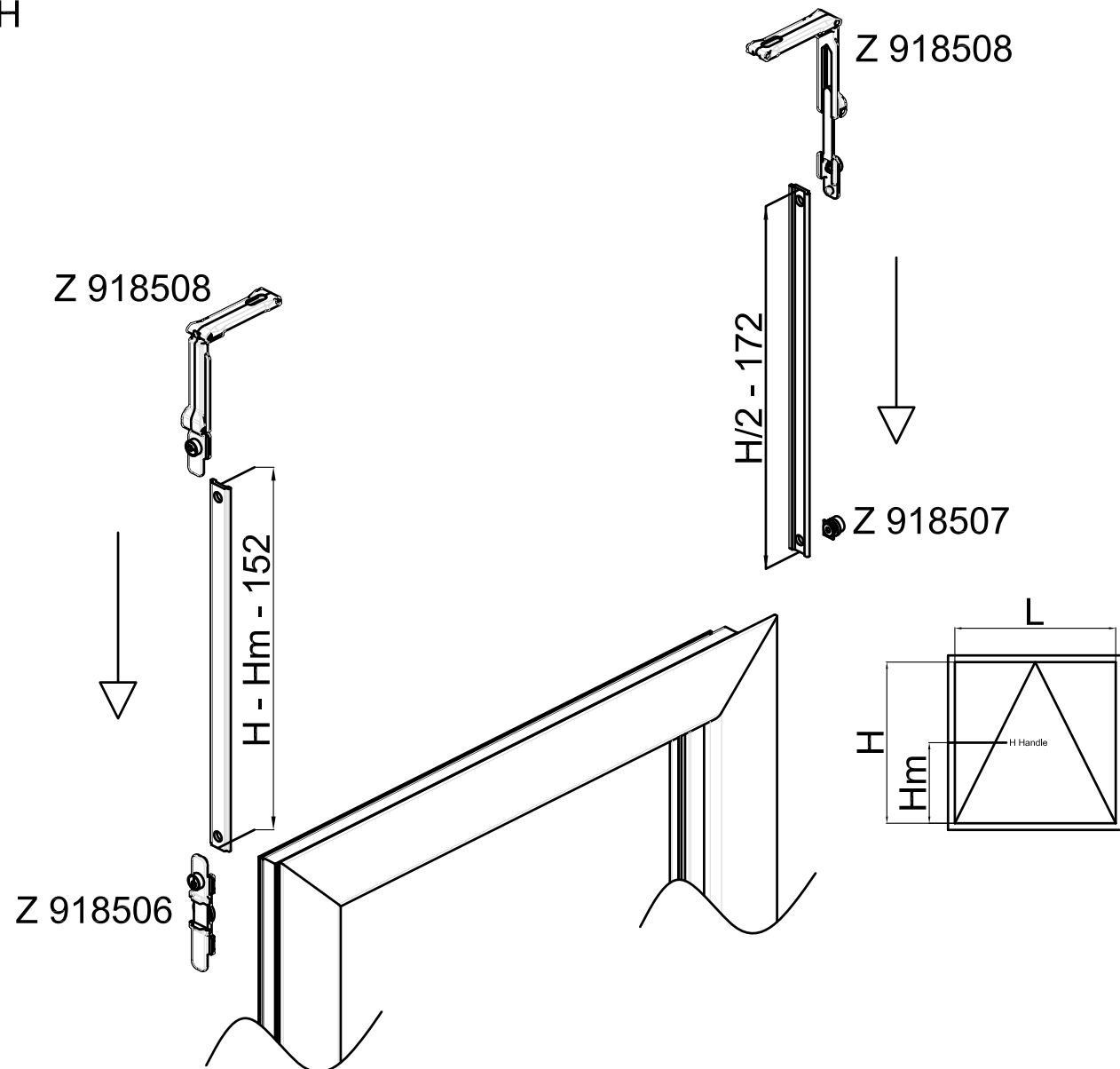

SASH  
 3)

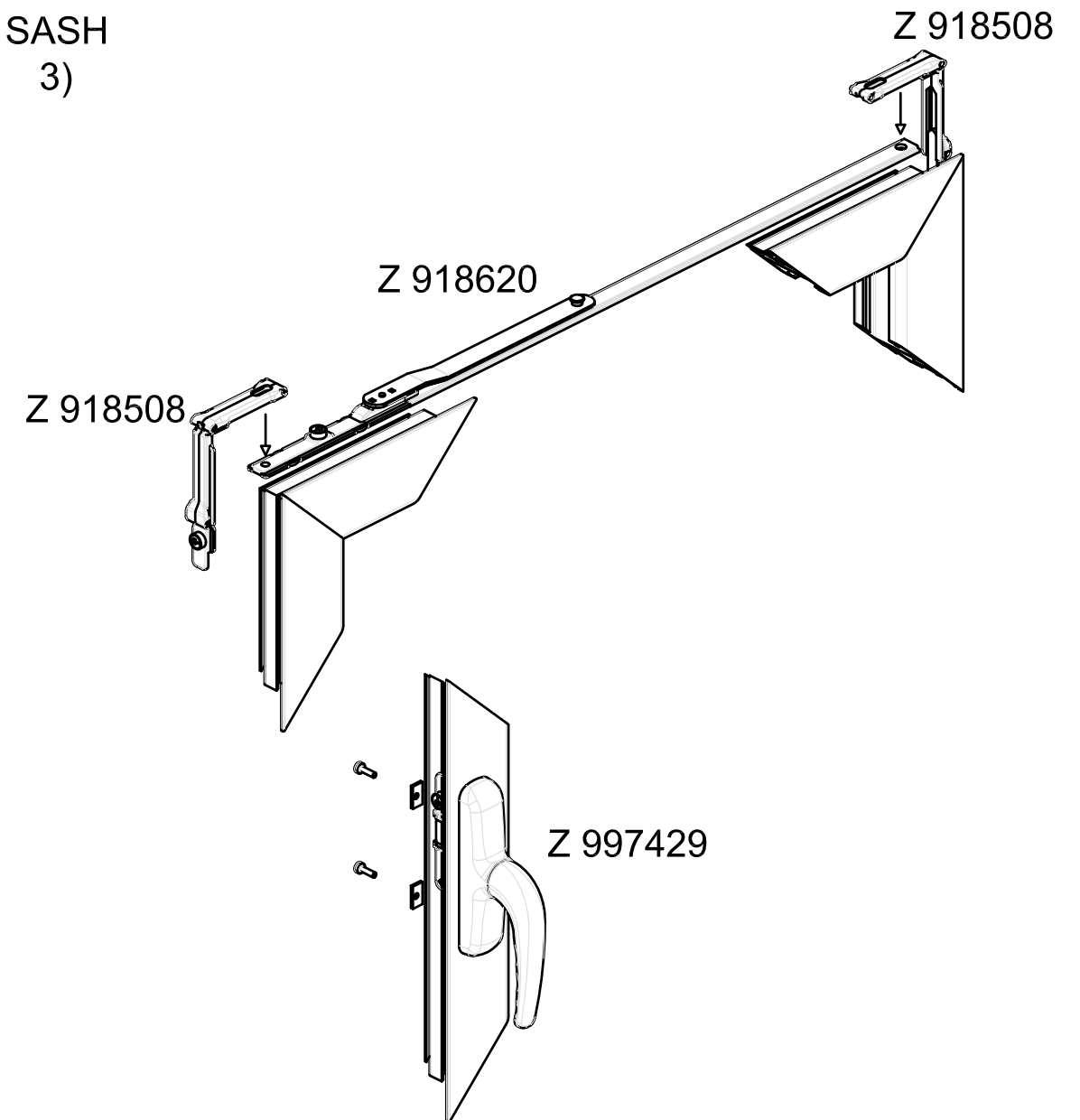

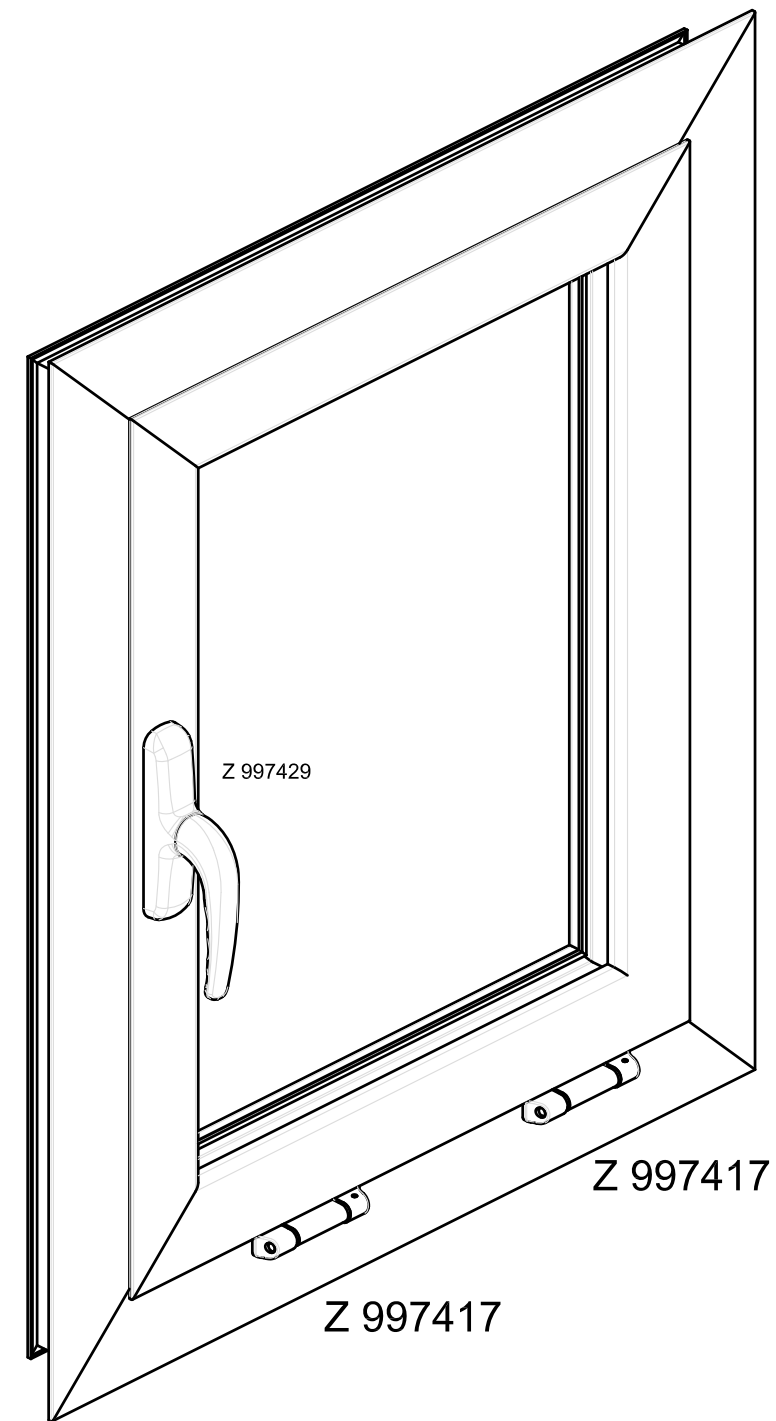
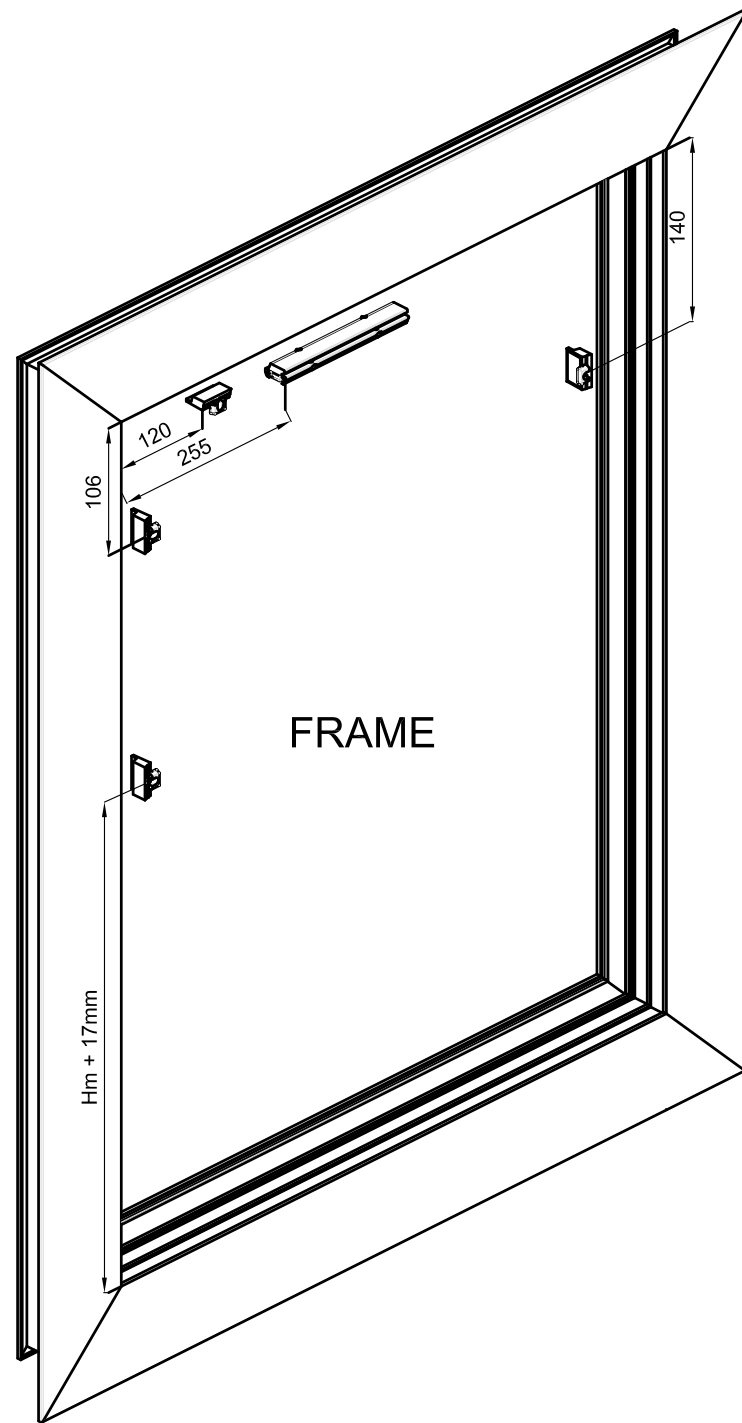

Z 997417

Place and fix this part to the frame

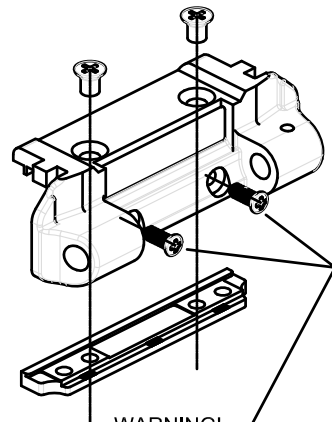

**WARNING!**  
It is mandatory to mount hinges with the provided self-threading screws

Place and fix this part to the sash

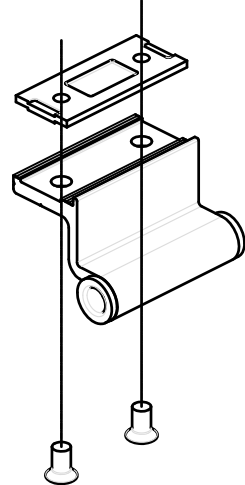

Insert the sash into the frame, then insert the pin

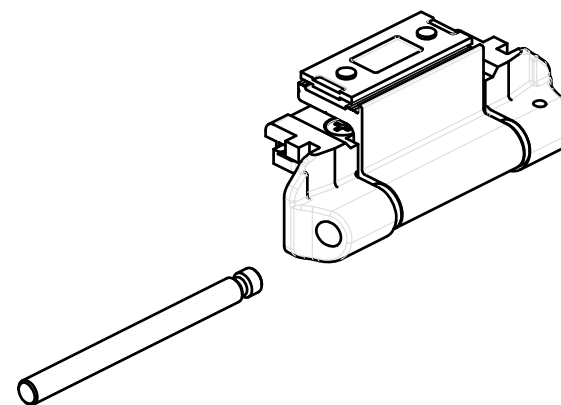

Tighten the pin with the grub screw

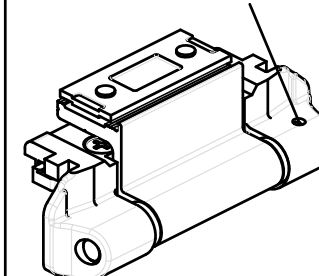

RODS MACHINING

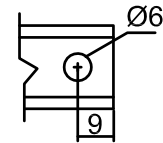

Lambda 45 NI  
 bottom hing opening inside  
 (Solution C)

SASH  
 1)

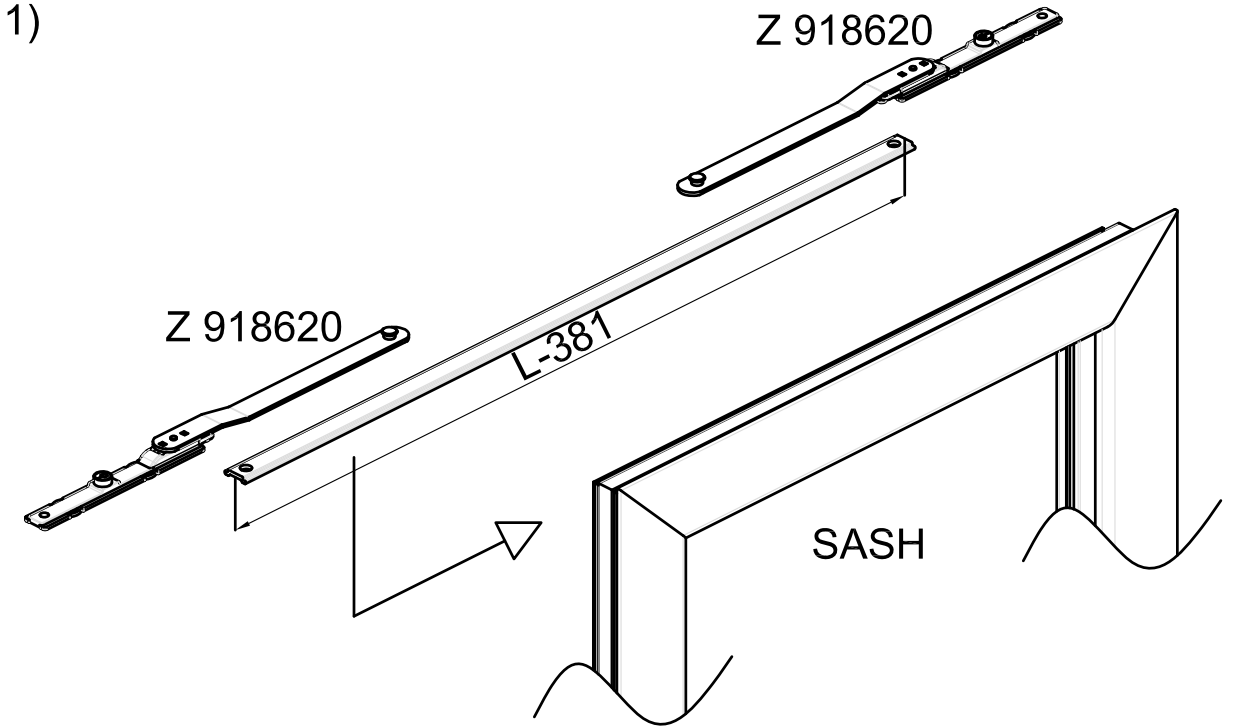

SASH  
 2)

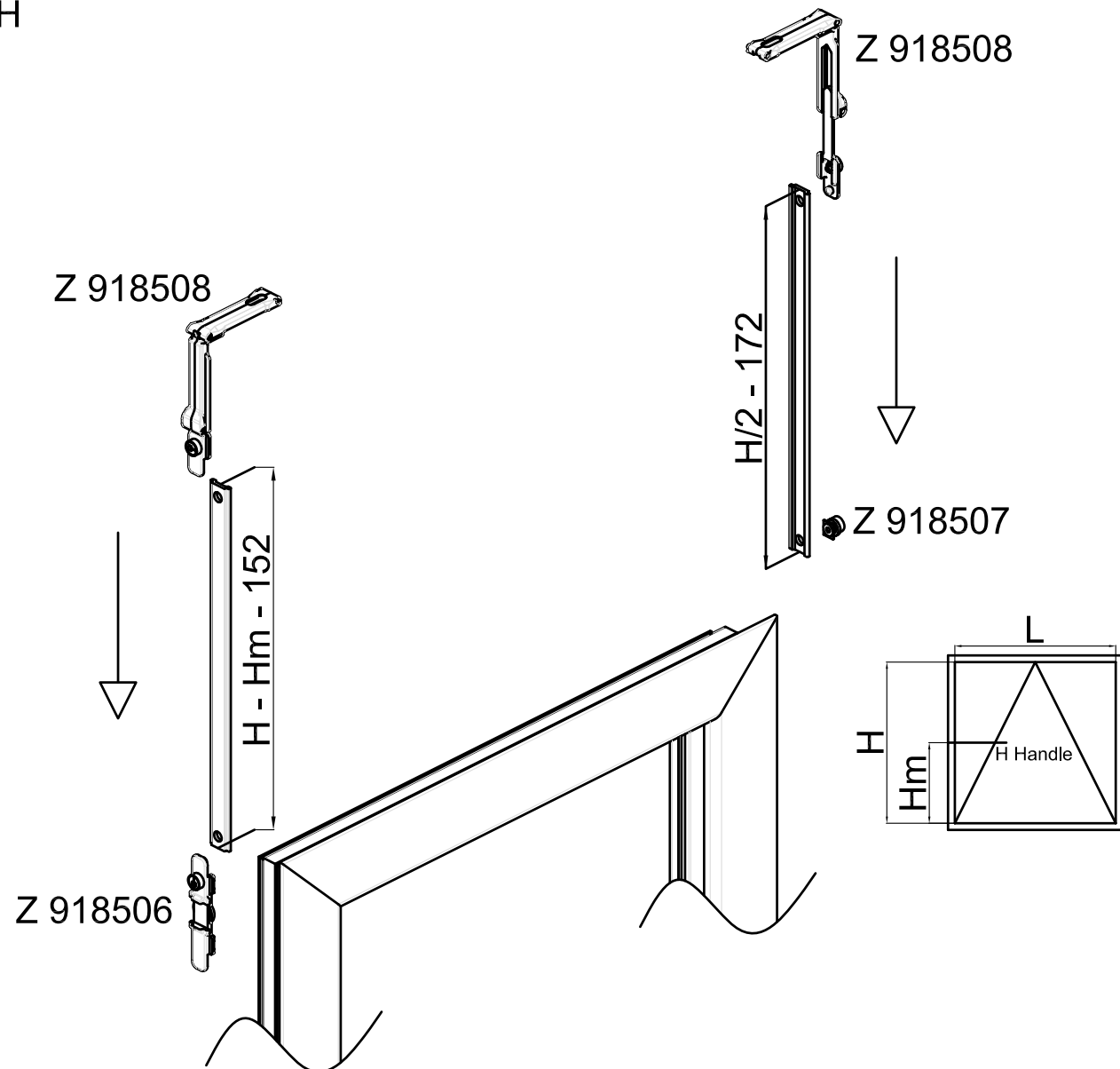

SASH  
 3)

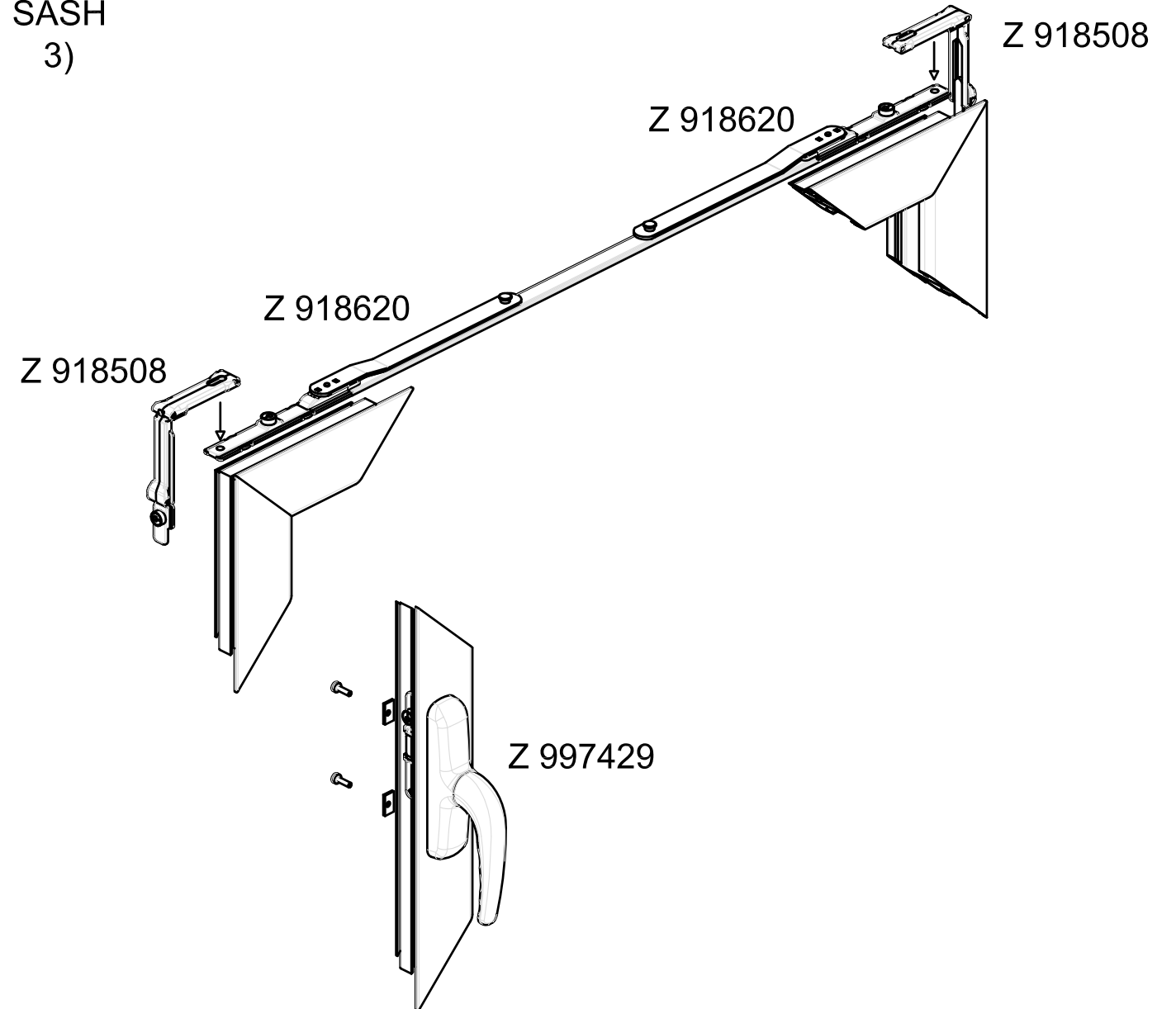

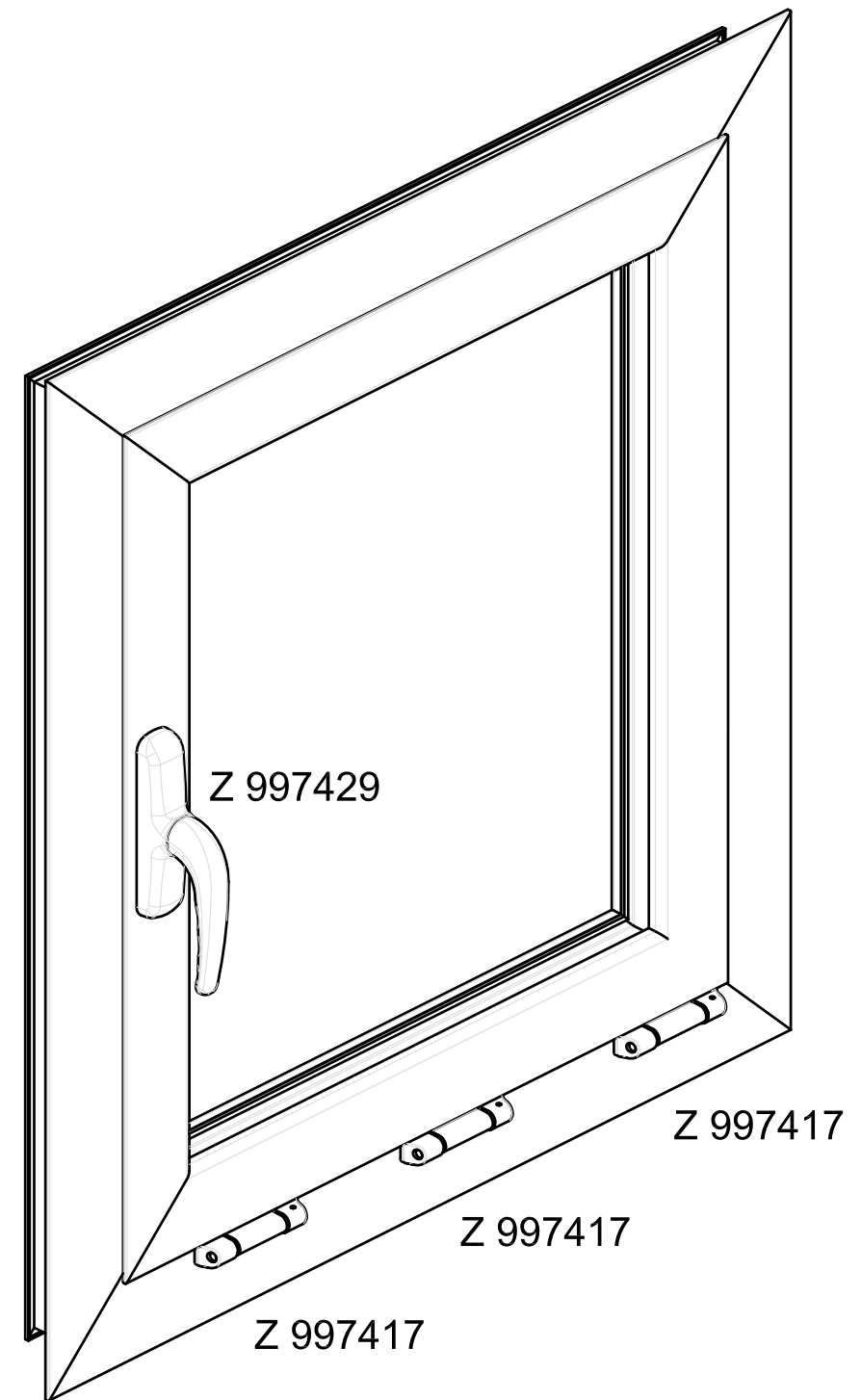
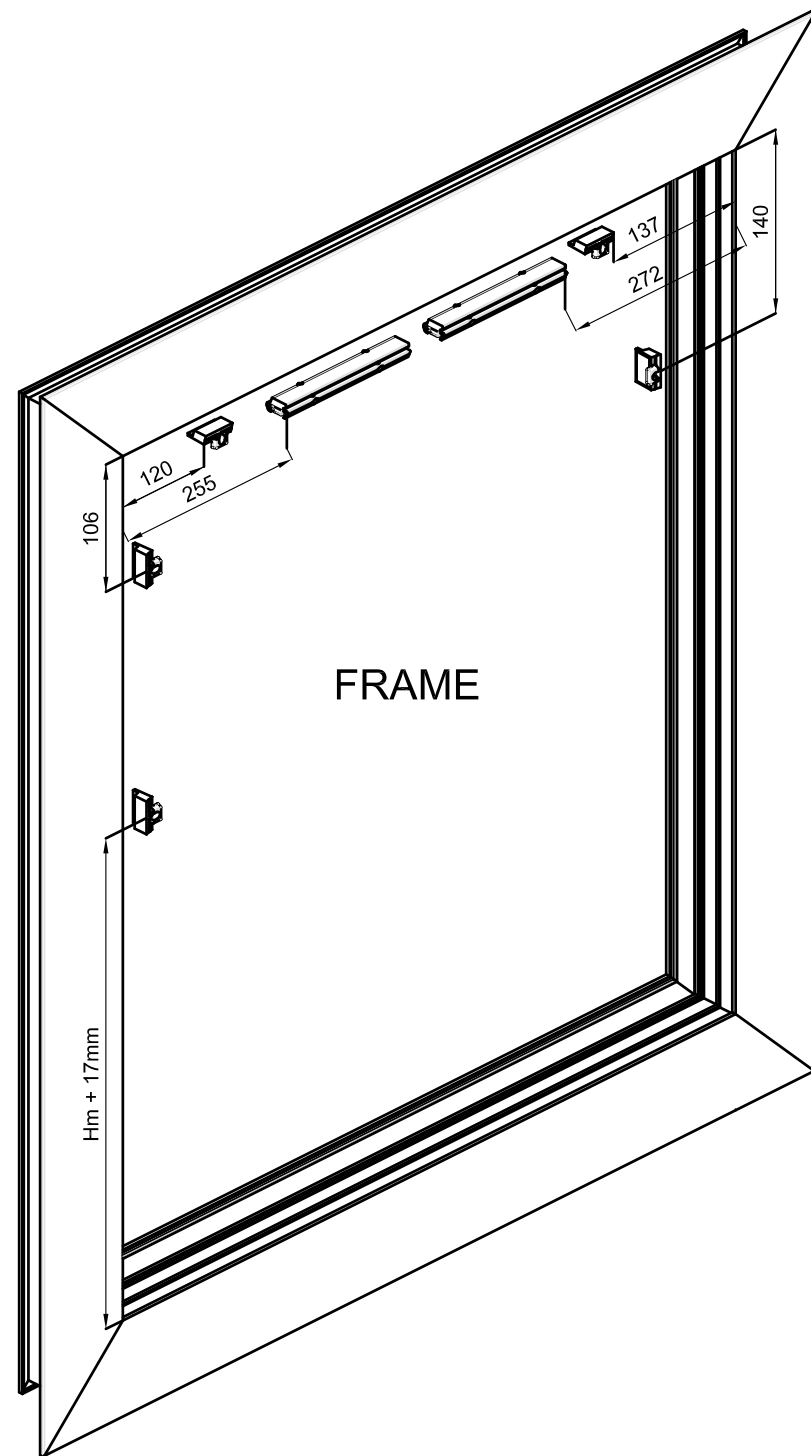

Z 997417

Place and fix this part to the frame

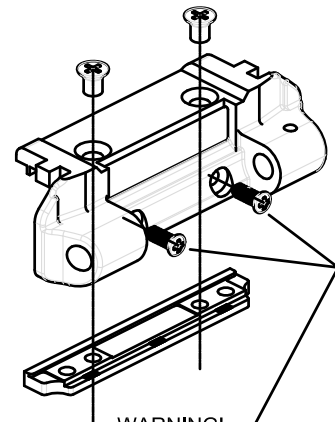

**WARNING!**  
It is mandatory to mount hinges with the provided self-threading screws

Place and fix this part to the sash

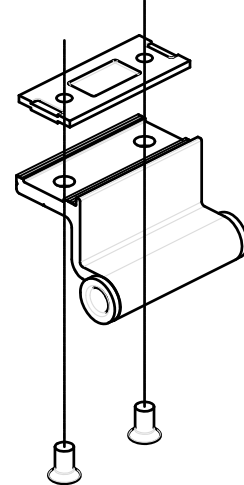

Insert the sash into the frame, then insert the pin

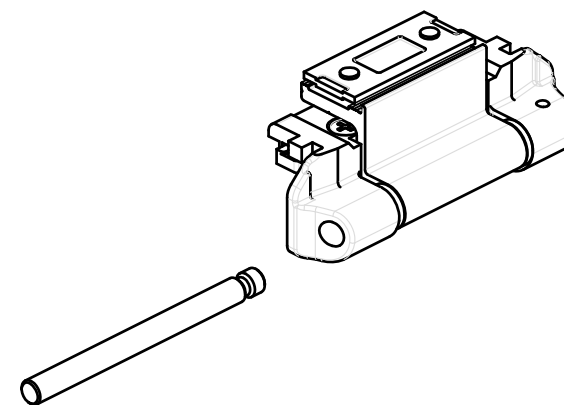

Tighten the pin with the grubscrew

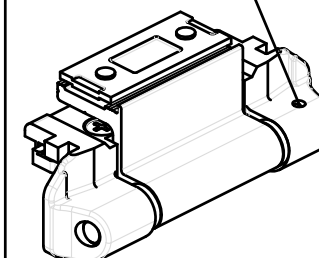

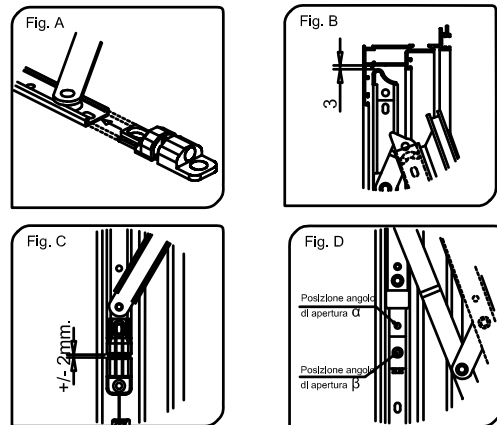
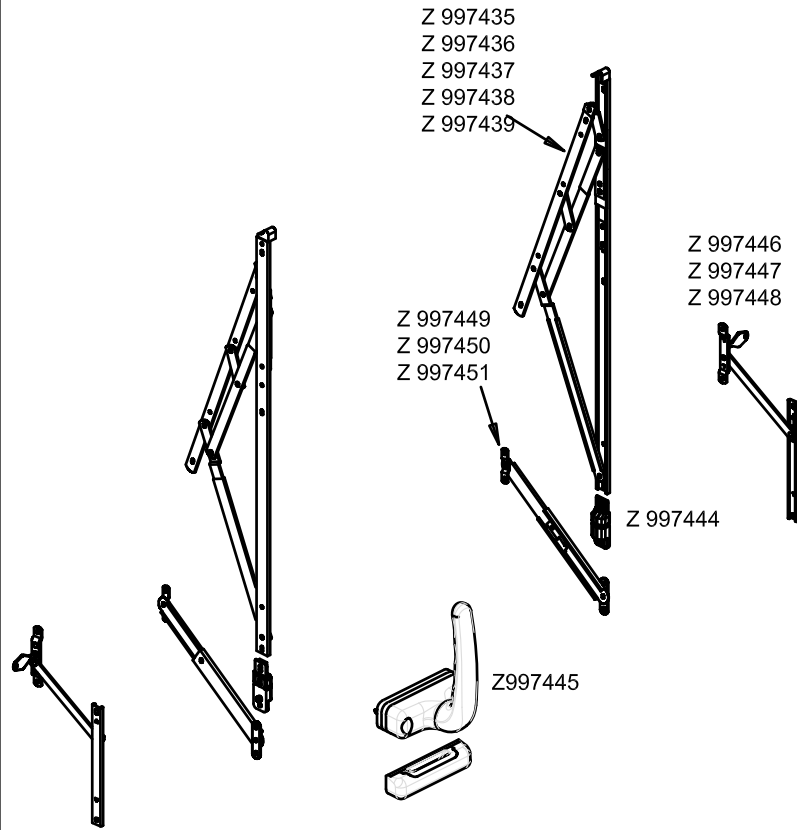

Make on the mullion and sash the positioning holes F1, F2 and F3 hole diameter 7 mm for the height regulator; Apply at the bottom of the Stay Hinge the height regulator Fig. A; Apply the Stay Hinge at 3mm. from the upper Cross Fig. B and apply the first mounting screws in slotted holes F1 and the hole F3 of the height regulator; Make the Stay Hinge adjustment through the height regulator Fig. C; Block the opening angle through the latch plate positioning Fig. D; Complete installation with screws (not included), lock all screws with Loctite suitable. Use screws suitable to the type and dimensions of the windows.

ADJUSTMENTS

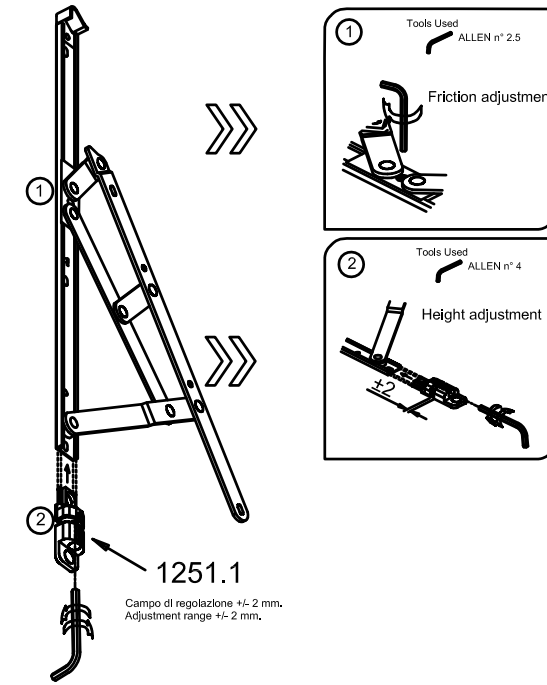

- The positioning indications are referred to the center line of the slots and holes;
- Check that all parts of the stay hinge are clean and lubricated;
- Use all holes and slots for fastening
- Periodically repeat cleaning, lubrication and check the tightness of the screws;

Stay hinge load capacity with and without limiters

Art	$\alpha$	7°	10°	15°	20°	25°	30°	35°
Z 997439		130Kg	128Kg	123Kg	116Kg	105Kg	91Kg	75Kg
Arms		Z 997435	Z 997436	Z 997437	Z 997438	Z 997439	Z 997440	Z 997441
Limitator		Z 997442	Z 997443	Z 997444	Z 997445	Z 997446	Z 997447	Z 997448
Indicated				1250	1250	-	1250	-

Art	$\alpha$	8°	15°	20°	25°	30°	35°
Z 997438		115Kg	111Kg	105Kg	95Kg	82Kg	65Kg
Arms		Z 997435	Z 997436	Z 997437	Z 997438	Z 997439	Z 997440
Limitator		Z 997442	Z 997443	Z 997444	Z 997445	Z 997446	Z 997447
Indicated				1250	-	1250	-

Art	$\alpha$	10°	15°	20°	25°	30°	35°	40°
Z 997437		95Kg	92Kg	87Kg	80Kg	72Kg	65Kg	50Kg
Arms		Z 997435	Z 997436	Z 997437	Z 997438	Z 997439	Z 997440	Z 997441
Limitator		Z 997442	Z 997443	Z 997444	Z 997445	Z 997446	Z 997447	Z 997448
Indicated				1250	1250	-	1250	-

Art	$\alpha$	10°	15°	20°	25°	30°	35°	40°
Z 997436		80Kg	79Kg	77Kg	72Kg	65Kg	56Kg	40Kg
Arms		Z 997435	Z 997436	Z 997437	Z 997438	Z 997439	Z 997440	Z 997441
Limitator		Z 997442	Z 997443	Z 997444	Z 997445	Z 997446	Z 997447	Z 997448
Indicated				1250	-	1250	-	-

Art	$\alpha$	15°	20°	25°	30°	35°	40°
Z 997435		55Kg	50Kg	47Kg	44Kg	40Kg	35Kg
Arms		Z 997435	Z 997436	Z 997437	Z 997438	Z 997439	Z 997440
Limitator		Z 997442	Z 997443	Z 997444	Z 997445	Z 997446	Z 997447
Indicated				1250	1250	-	-

Application Range

Art	L inch	L mm	Opening $\alpha/\beta$	Load Kg	Min/Max H mm	Max L mm
Z 997435	10	260.5	35/45	50/36	450/600	1200
Z 997436	12	311	30/40	70/43	600/800	1200
Z 997437	14	349.5	30/40	80/50	800/1000	1200
Z 997438	16	410.5	25/35	95/65	1000/1200	1200
Z 997439	18	458.5	25/35	108/78	1200/1400	1200

Drilling Indication

Art	L inch	$\beta$	$\alpha$	A	B	C	D	E	F	G	H	I	J
Z 997435	10	45	35	160	183.5	n.p.	211.5	254	263	205	40	n.p.	n.p.
Z 997436	12	40	30	172.5	214	n.p.	249.5	305	313	252.5	40	40	n.p.
Z 997437	14	40	30	180.5	227	n.p.	288.5	344	351	275	40	70	n.p.
Z 997438	16	35	25	173	225	46	348.5	404.5	412.5	313.5	40	108.5	n.p.
Z 997439	18	35	25	179.5	239.5	46	393.5	450	458.5	340	70	105	n.p.

For Alluminum minimum thickness 2mm best with threaded insert  
For Alluminum thickness 4mm best with self-tapping screws  $\varnothing 4,8$  + Loctite

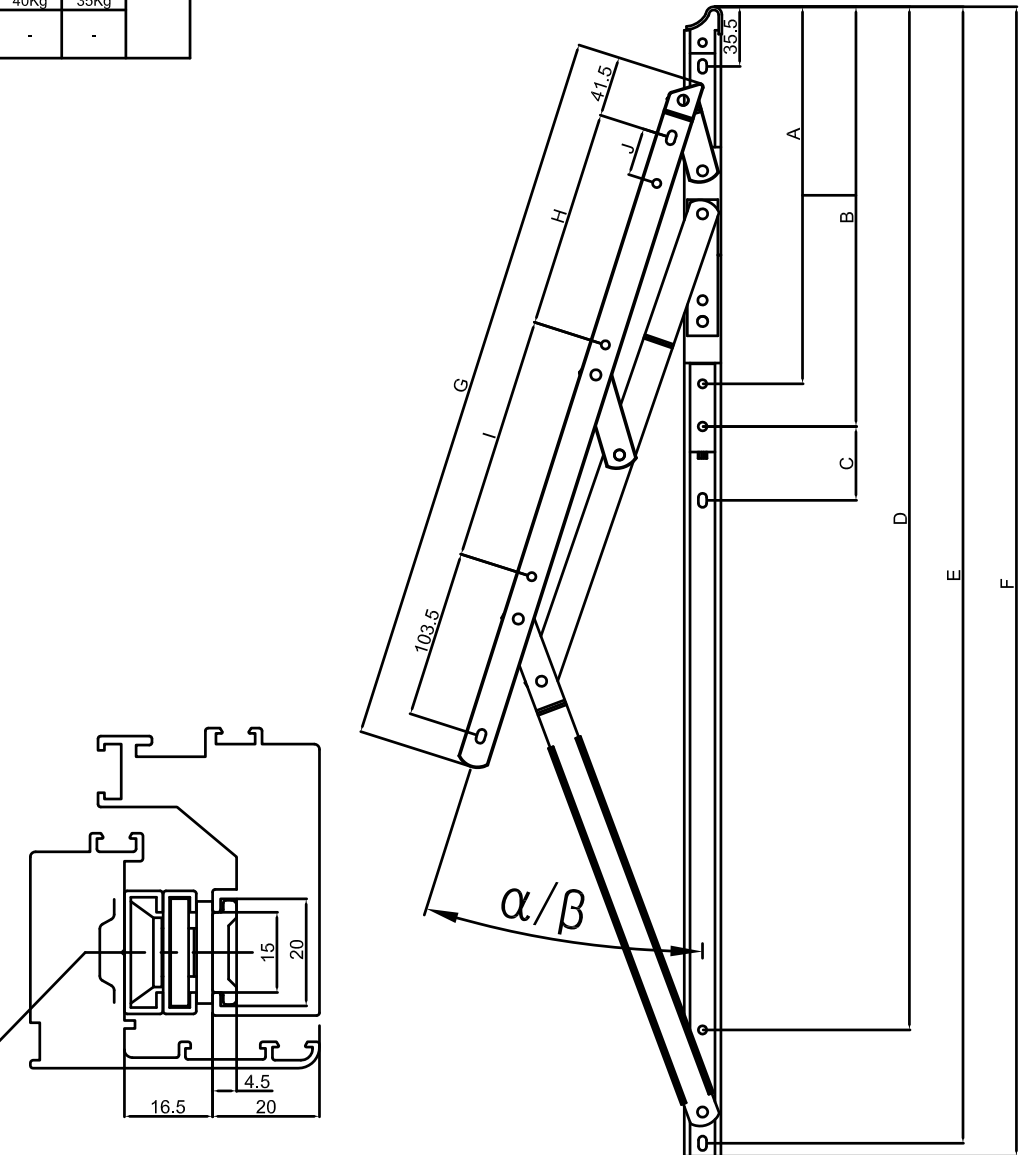

Opening side change

Open the handle and remove the spring [1].

Unscrew the screw [2] and remove the nib [3], then turn the handle [4] to change the hand.

After assembling the nib and the screw, insert the spring [1] in the opposite side.

Available thicknesses 3, 4, 5 mm. Combine them to obtain the thickness you want.

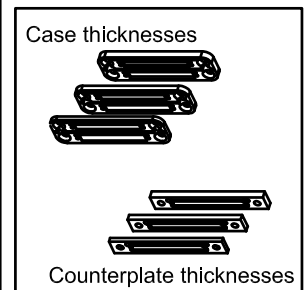
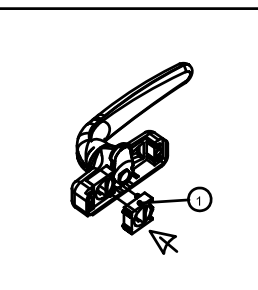
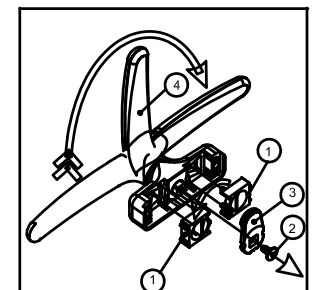
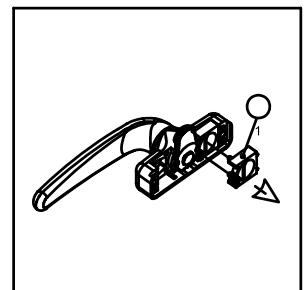

External opening assembling

Make the holes on the profile as indicated here.

Assembly the counterplate with the parts [6] [7] [8], then fix it on the frame by the screws M5 X 12 as indicated in the figure.

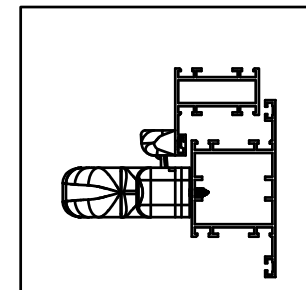
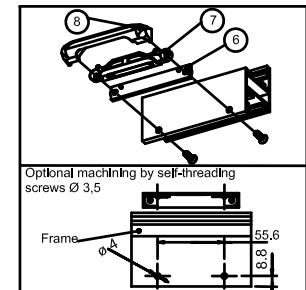
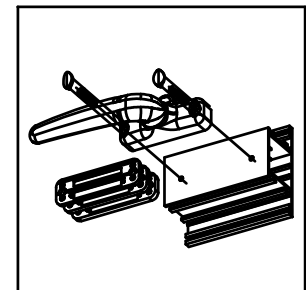
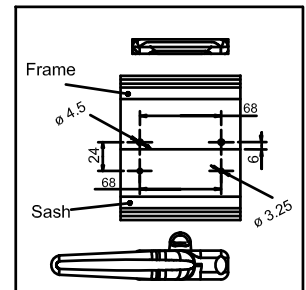



Lambda 45 / 110 NI  
 Limiter for opening

LIMITER Z 997446 - Z 997447 - Z 997448

DESCRIPTION	ART.	A (INCH)	A (MM)	B (MM)	C (MM)
Friction limited arm	Z 997446	6"	150,5	131	85,4
	Z 997447	8"	201	184	152
	Z 997448	10"	254	236	180
Additional release key	Z 918611				

AISI 304 stainless steel arms, Delrin opening limit block, die-cast aluminum release key.

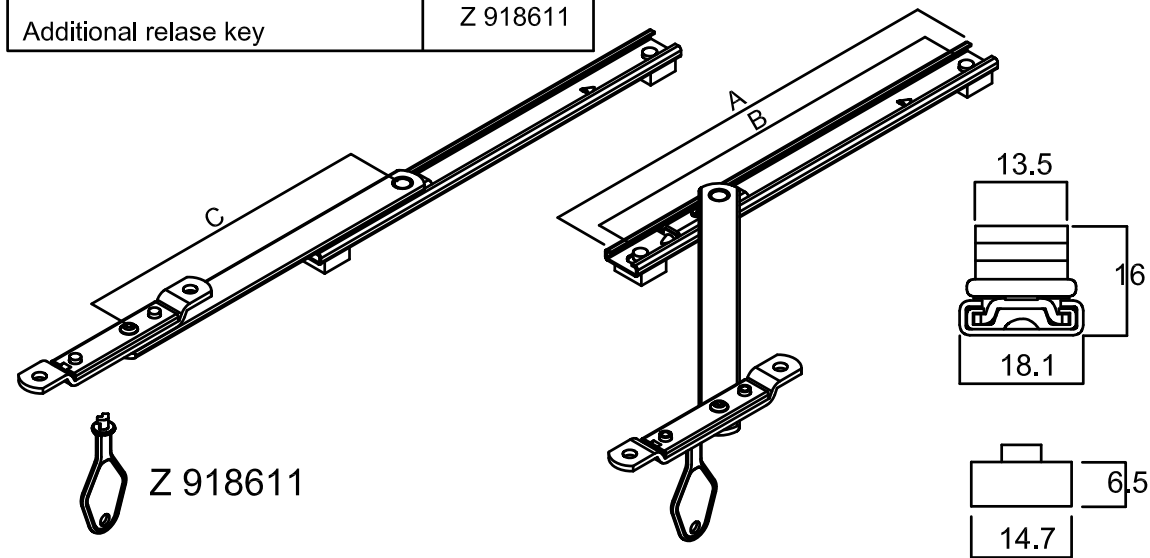

SASH

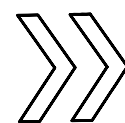
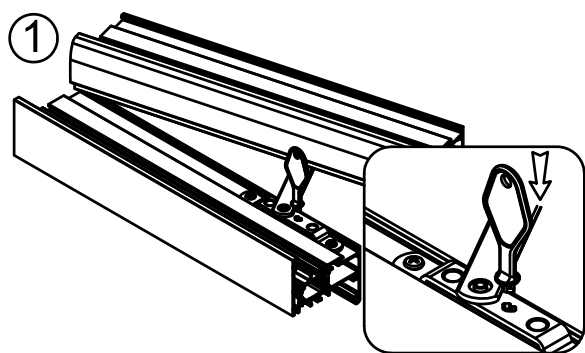
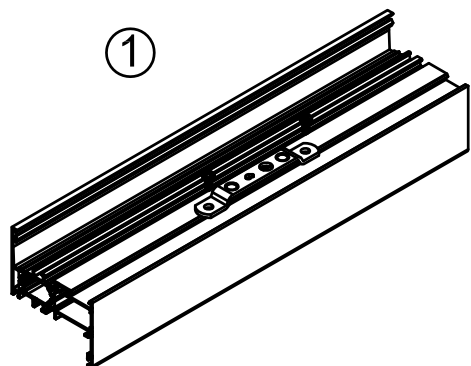
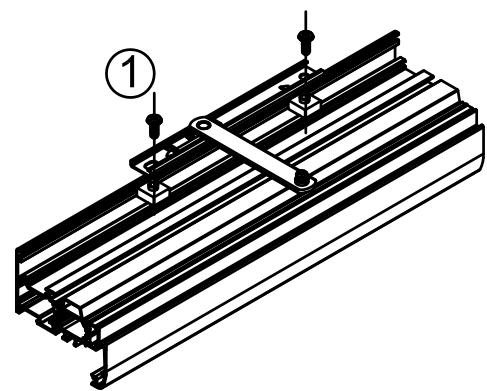
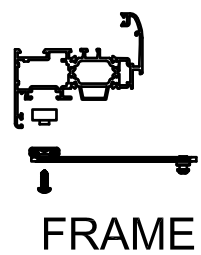

②

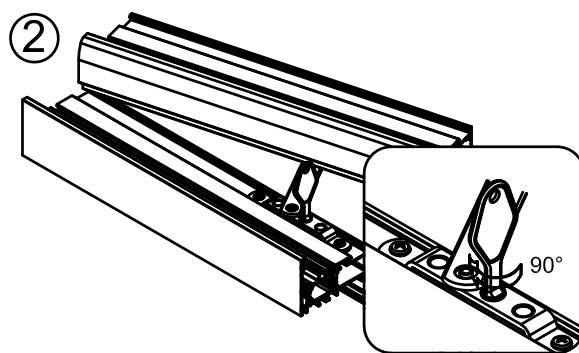
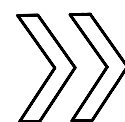
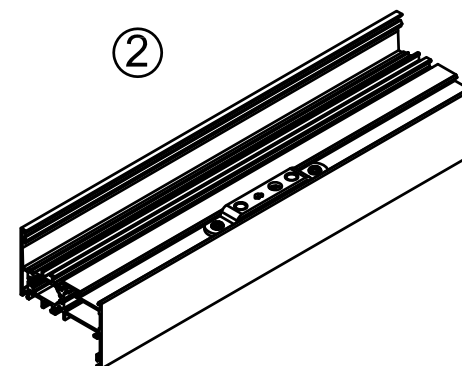
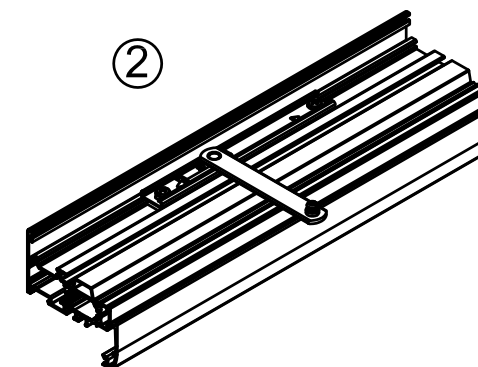
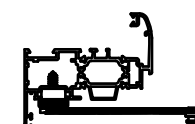

③

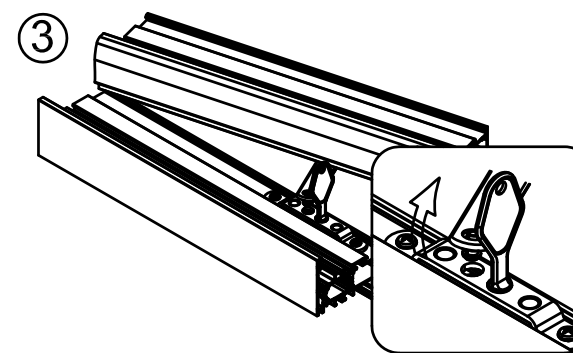





Lambda 45 NI  
 Side hung opening outside

Z 997454

L (") - 12

L(mm) - 313

L Min Sash - 340mm

Max open degree - 90°

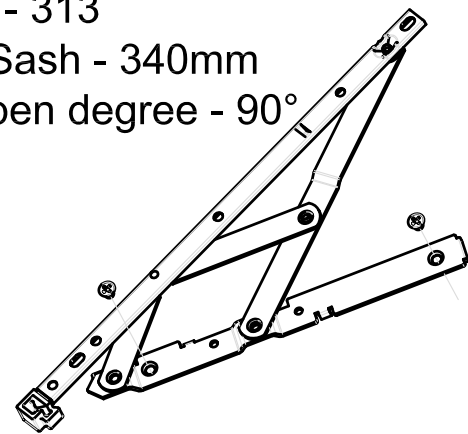

Load 20Kg with  
 L 450mm X H 1200mm

Fig. 1

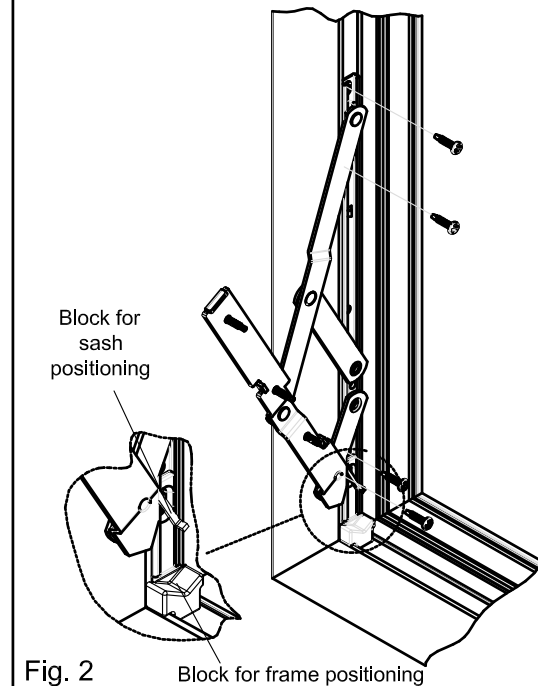

Fig. 2

Fig. 3

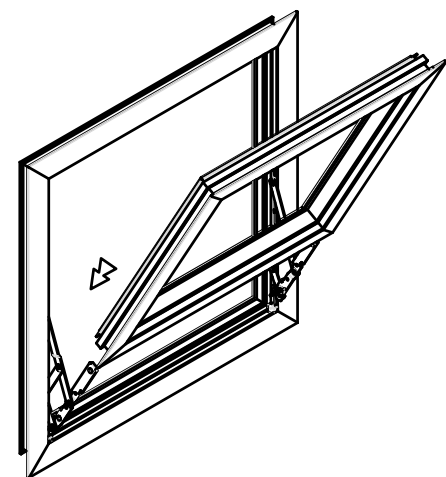
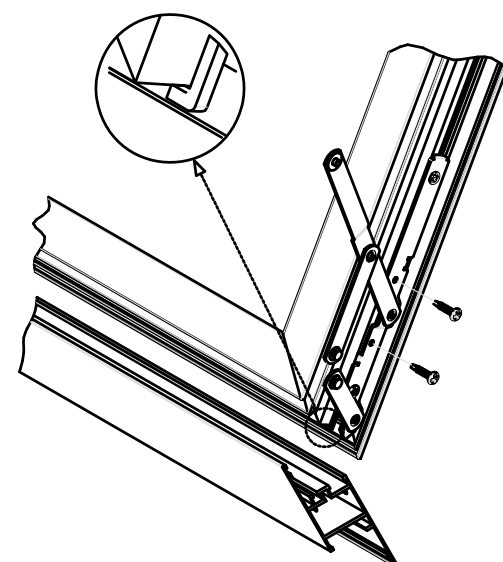
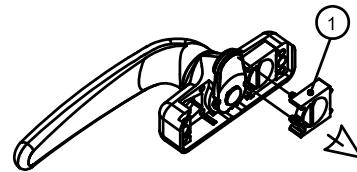

Fig. 4



Open the handle and remove the spring [1].



Opening side change

Unscrew the screw [2] and remove the nib [3], then turn the handle [4] to change the hand.

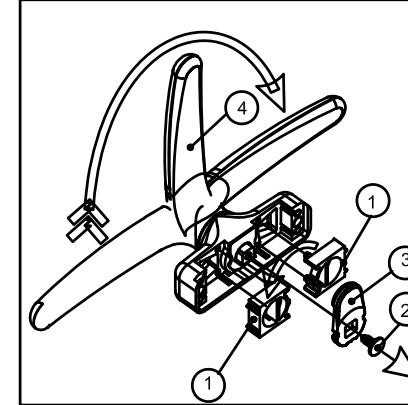

After assembling the nib and the screw, insert the spring [1] in the opposite side.

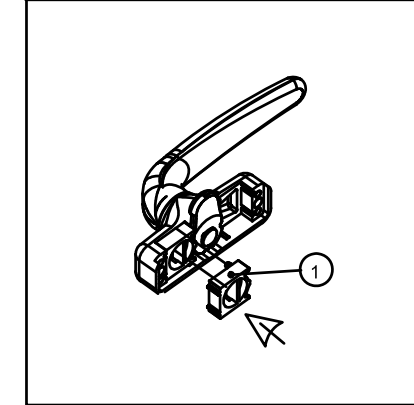

Available thicknesses 3, 4, 5 mm. Combine them to obtain the thickness you want.

Case thicknesses

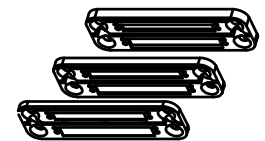

Counterplate thicknesses

Make the holes on the profile as indicated here.

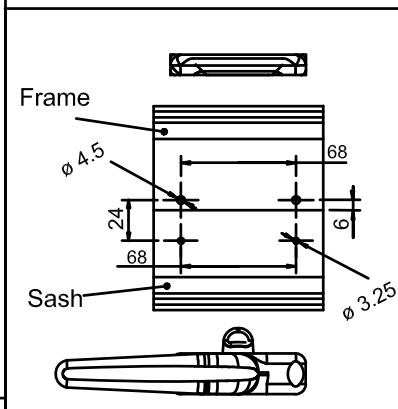

External opening assembling

Assembly the counterplate with the parts [6] [7] [8], then fix it on the frame by the screws M5 X 12 as indicated in the figure.

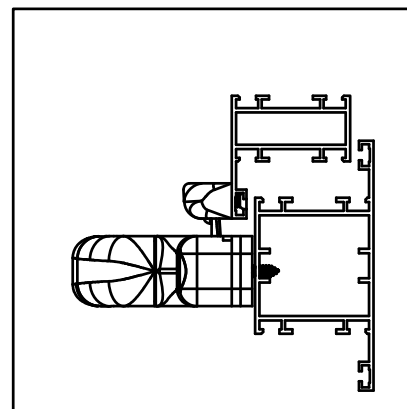
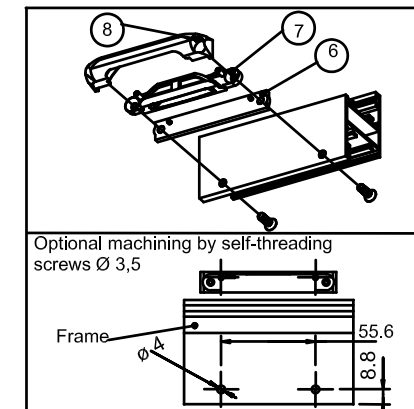
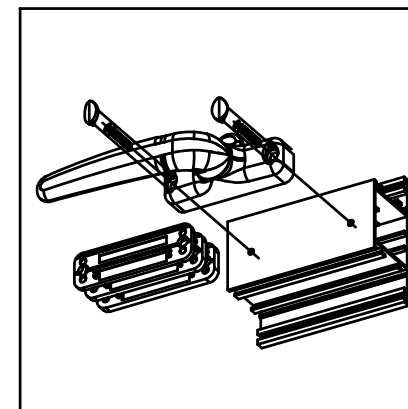

Make the holes on the profile as indicated here.

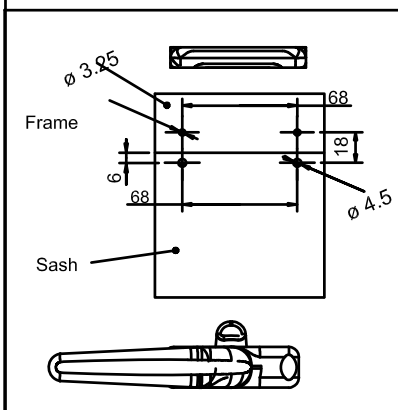

Inside opening assembling

Fix the handle by the screws M5 x 12 as indicated in the figure.

Assembly the parts [6], [7] and if it is necessary also the thicknesses [A], fix them on the profile by self-threading screws, insert the cover-counterplates [8]

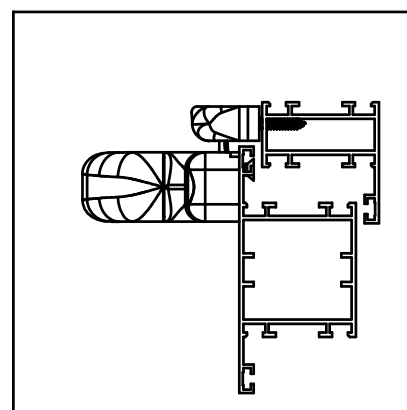
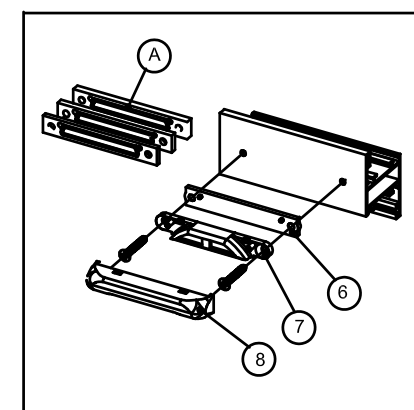
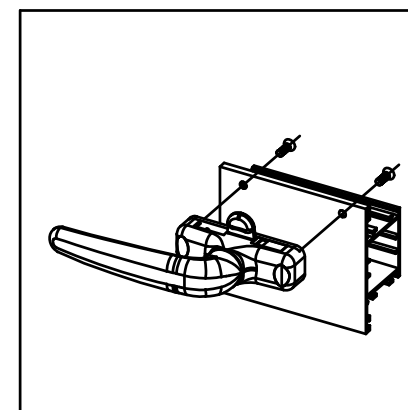



Lambda 45 NI  
for secondary sash

For Euro Groove system

TWO-WAY MECHANISM FOR SECONDARY SASH

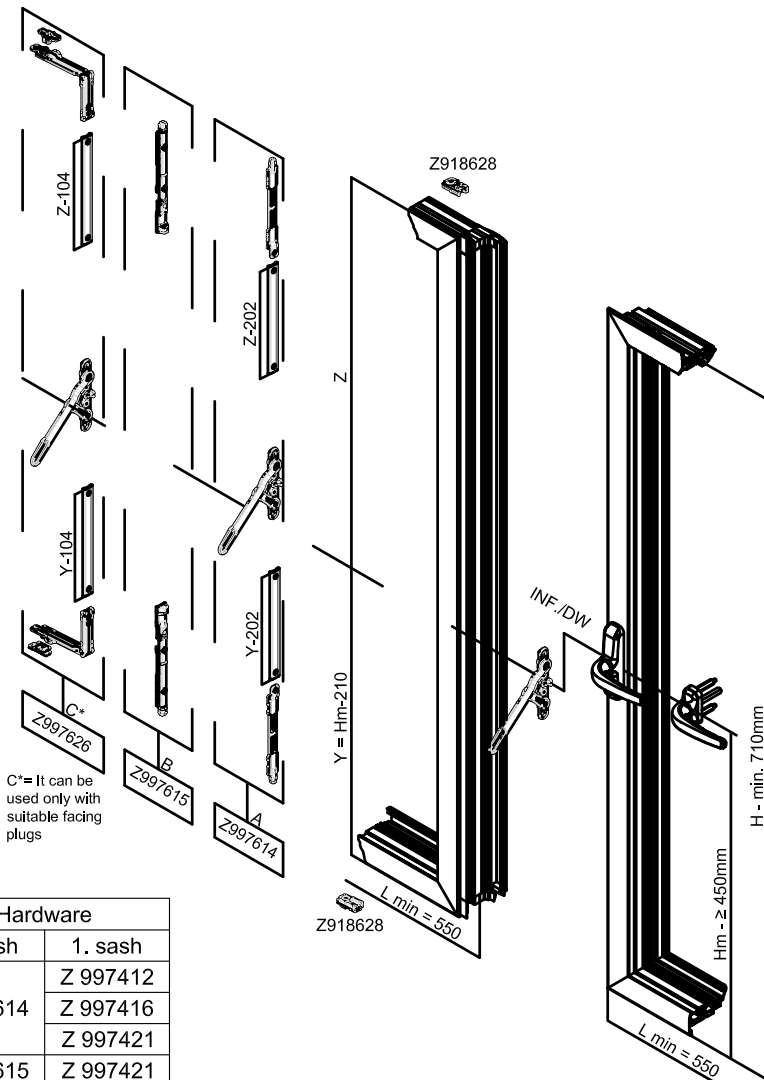

Hardware	
2. sash	1. sash
Z 997614	Z 997412
Z 997615	Z 997416
Z 997626	Z 997421
	Z 997421

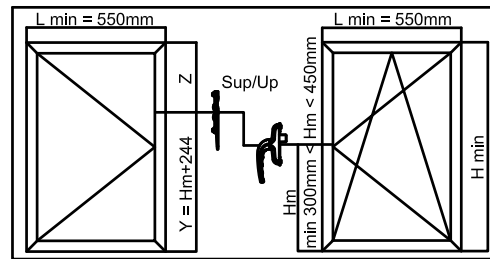

RODS MACHINING

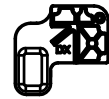
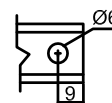

A3400.50  
Drilling template

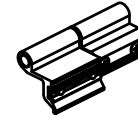

Z 997253  
Fast mounting hinge (2 parts)



Z 918628  
one rod junction

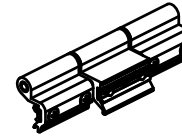

Z 997247  
Fast mounting hinge (3 parts)

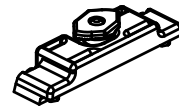

Z 997423  
Sash stopper

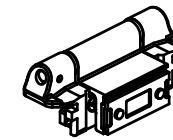

Z 997417  
Comb Hinge - Load 120 kg



Z 997424  
Additional intermediate third closing point adjustable

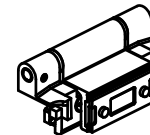

Z 997418  
Comb Hinge - Load 80 kg

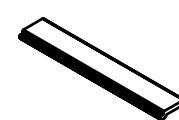

K 910137  
Polyamide rod

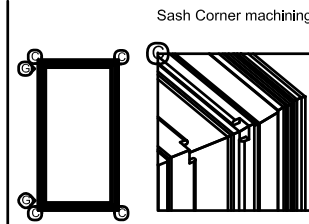
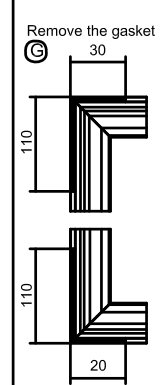
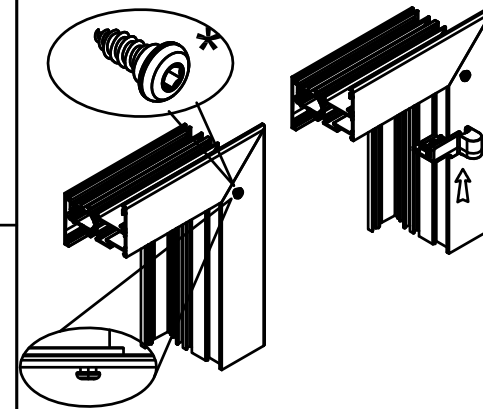

Remove the gasket  
30  
110  
20

Sash Corner machining

Cut seals and machining angles are basic condition for ensuring the proper operation of the device III

Technical information

H	L	Load capacity									
		2 wings	80Kg	100%	3 wings	160Kg	100%	100%	100%	100%	100%
2400	100%	100%	100%	100%	100%	100%	100%	100%	100%	100%	100%
2300	100%	100%	100%	100%	100%	100%	100%	100%	100%	100%	100%
2200	100%	100%	100%	100%	100%	100%	100%	100%	100%	100%	100%
2100	100%	100%	100%	100%	100%	100%	100%	100%	100%	100%	100%
2000	100%	100%	100%	100%	100%	100%	100%	100%	100%	100%	100%
1900	100%	100%	100%	100%	100%	100%	100%	100%	100%	100%	98%
1800	100%	100%	100%	100%	100%	100%	100%	100%	100%	100%	90%
1700	100%	100%	100%	100%	100%	100%	100%	100%	100%	95%	82%
1600	100%	100%	100%	100%	100%	100%	100%	100%	100%	85%	73%
1500	100%	100%	100%	100%	100%	100%	100%	100%	90%	76%	65%
1400	100%	100%	100%	100%	100%	100%	100%	96%	80%	67%	57%
1300	100%	100%	100%	100%	100%	100%	100%	84%	70%	58%	X
1200	100%	100%	100%	100%	100%	90%	73%	60%	X	X	X
1100	100%	100%	100%	100%	97%	78%	62%	50%	X	X	X
1000	100%	100%	100%	100%	83%	65%	51%	X	X	X	X
H	L	370	400	500	600	700	800	900	1000	1100	1200

Calculate the sash load capacity in percentage as indicated in the table (according to the dimensions)  
Example Z 997425 - Sash L1200xH2100:120Kg (100%) x 75/100= 90Kg (A)

Inversioni di apertura  
Destra/Sinistra  
Direction of opening  
Right/Left

PREASSEMBLED RX



INVERSION LX

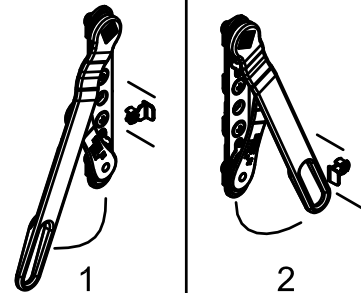

Configurations

2700	 ① Z997614 + ② Z918628 + ③ K910137 + ④ Z997422 + ⑤ Z997424	 ① Z997614 + ② Z918628 + ③ K910137 + ④ Z997422 + ⑤ Z997424	 ① Z997614 + ② Z918628 + ③ K910137 + ④ Z997422 + ⑤ Z997424	 ① Z997614 + ② Z918628 + ③ K910137 + ④ Z997422 + ⑤ Z997424
2200	 ① Z997614 + ② Z918628 + ③ K910137 + ④ Z997422 + ⑤ Z997424	 ① Z997614 + ② Z918628 + ③ K910137 + ④ Z997422 + ⑤ Z997424	 ① Z997614 + ② Z918628 + ③ K910137 + ④ Z997422 + ⑤ Z997424	 ① Z997614 + ② Z918628 + ③ K910137 + ④ Z997422 + ⑤ Z997424
1400	 ① Z997614 + ② Z918628 + ③ K910137 + ④ Z997422	 ① Z997614 + ② Z918628 + ③ K910137 + ④ Z997422	 ① Z997614 + ② Z918628 + ③ K910137 + ④ Z997422	 ① Z997614 + ② Z918628 + ③ K910137 + ④ Z997422
450	 ① Z997614 + ② Z918628 + ③ K910137 + ④ Z997422	 ① Z997614 + ② Z918628 + ③ K910137 + ④ Z997422	 ① Z997614 + ② Z918628 + ③ K910137 + ④ Z997422	 ① Z997614 + ② Z918628 + ③ K910137 + ④ Z997422

Check the load capacity chart

