

Volato 30 NI

Sliding windows & doors

Volato - Sliding construction

Contents - Volato 30 NI

Page

Contents

2

Series Information

3 - 6

Profile overview | Static profile value

11 - 14

Profiles | Connections

15 - 28

Glazing

31 - 38

Sections / Details

41 - 74

System-dependent accessories

81 - 88

Fittings

101 - 102

Processing

151 - 190

002000200



Series information*

<p>Design features</p>	<ul style="list-style-type: none"> • Variety of design possibilities for sliding windows and sliding doors • Arrangement of the sashes: from double-sash up to fourfold-sash, two track constructions, schematic in accordance to the separate chart • Sash weight max. 150kg • Sash height max. 2200mm by max. sash width 1500mm • Fixed frames: One-chamber profiles • Reinforced labyrinth-profiles • Complementary Fittings, Accessories, supplementary profiles, tools and auxiliary accessories
<p>Surfaces</p>	<ul style="list-style-type: none"> • Anodisation in accordance with DIN 17611 • Plastic coating (wet paint, powder coating lacquer) in accordance with DIN 50939
<p>Connecting technology</p>	<ul style="list-style-type: none"> • Same frame profile horizontal and vertical • Simple processing because of linear joints in sash frames • Drilled profile joints
<p>Elevation width</p>	<ul style="list-style-type: none"> • Fixed frame: lateral 44,5 mm around, at the top/lower 45 mm • sash frame: lateral 53,4 mm, at the top/lower 60 mm • Labyrinth: 34 mm • Sash joint scheme B and C: 110 mm
<p>Profile depth</p>	<ul style="list-style-type: none"> • Fixed frame: 91 mm • Sash frame: horizontal 31 mm, vertikal 34 mm
<p>Glazing</p>	<ul style="list-style-type: none"> • Glass thickness between 6 mm and 24 mm
<p>Gaskets</p>	<ul style="list-style-type: none"> • Plastic sliding gasket • Pile with middle bridge in the labyrinth-area • Glazing gaskets: U-shaped gasket profiles, optionally can be drawn in continuously or drawn in mitre joint
<p>Tandem roller</p>	<ul style="list-style-type: none"> • Adjustable in hight or fixed • Combination of single-roll and tandemroll for a sash weight of 100kg

* All standards referred to herein, were valid at time of printing.

Valid test reports as well as technical information can be found in the download area of the site www.hueck.com

003000300



Scheme A - two track construction

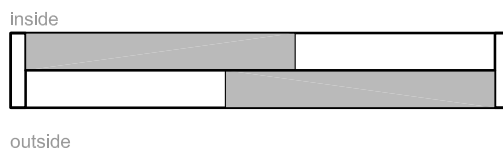
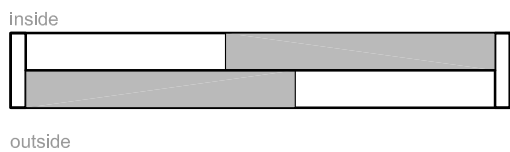

Scheme B - two track construction

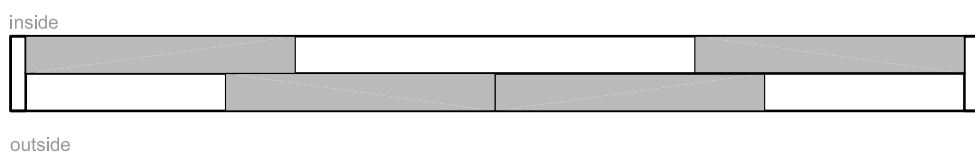

Scheme C - two track construction

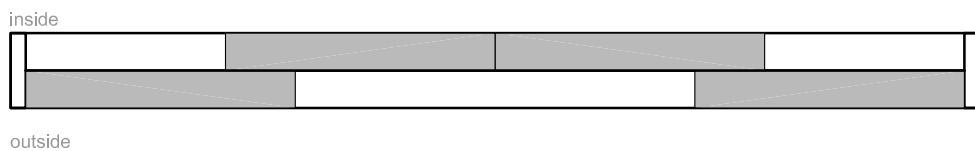

Scheme D - three track construction

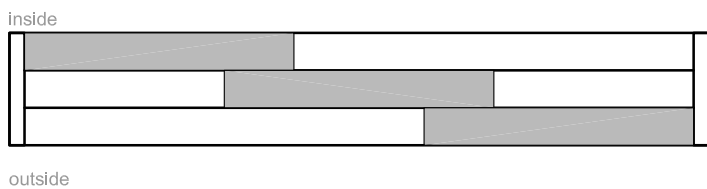

**P 816202
+
P 816202**

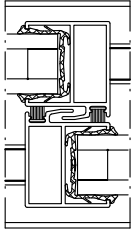

**P 816202
+
P 816204**

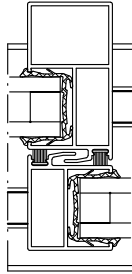

**P 816204
+
P 816204**

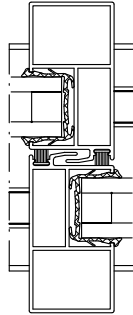

**P 816205
+
P 816205**

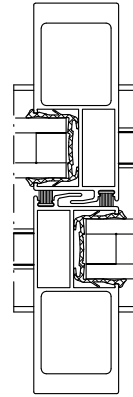

**P 816206
+
P 816206**

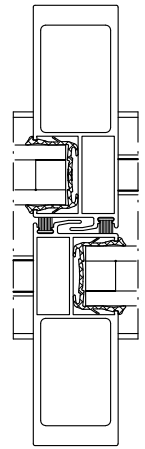

Sash height

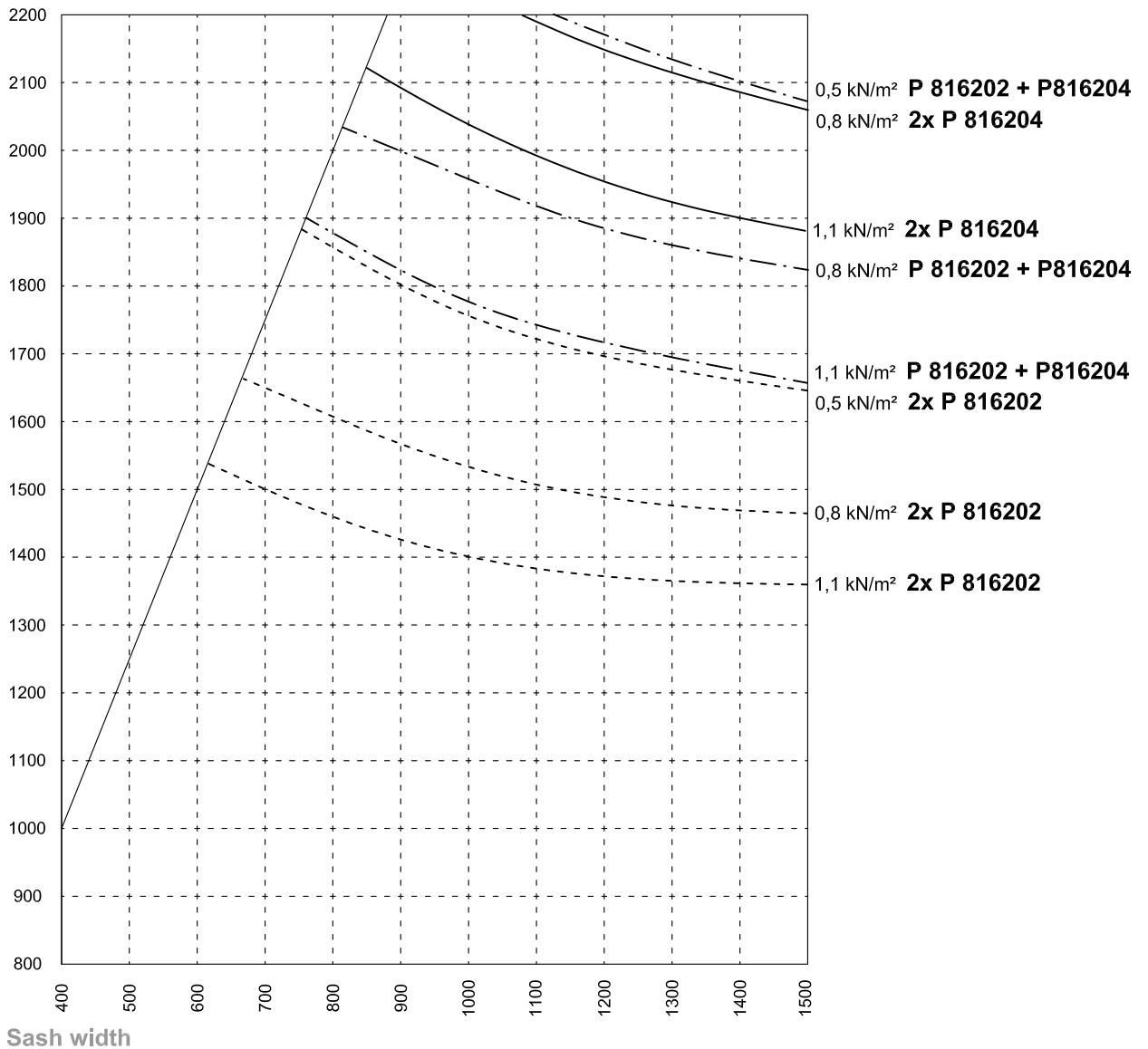



005006500

Min. sash width 400mm Aspect ratio w/h of the sash should not fall short of 1/2.5



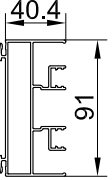
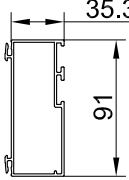
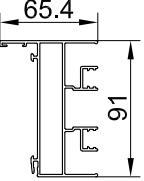
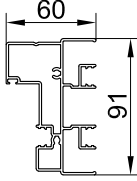
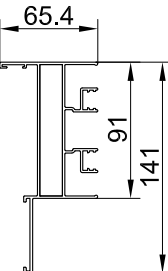
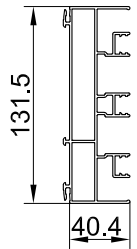
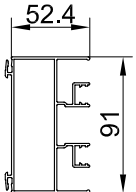
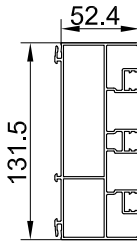
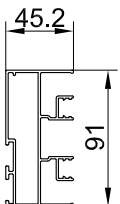
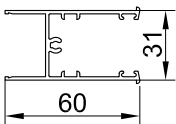
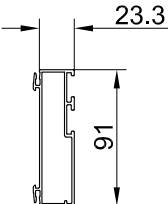
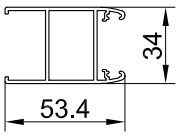
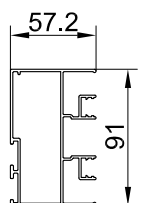

Profile overview and static profile values for Series Volato 30 NI



	Profile number	Horizontal axis		Vertical axis		External perimeter complete	Page -		Profile number	Horizontal axis		Vertical axis		External perimeter complete	Page -
		J_x (cm ⁴)	W_x (cm ³)	J_y (cm ⁴)	W_y (cm ³)					J_x (cm ⁴)	W_x (cm ³)	J_y (cm ⁴)	W_y (cm ³)		
	P 816101	55	12	10	4	562	15		P 816108	4	3	40	9	347	18
	P 816102	64	13	14	4	615	16		P 816300	57	12	17	5	586	19
	P 816103	116	13	18	5	708	16		P 816109	150	15	22	6	731	20
	P 816104	63	14	20	7	586	15		P 816110	167	29	25	10	755	20
	P 816105	12	5	56	12	555	17		P 816200	7	2	5	3	365	21
	P 816106	4	3	40	9	323	17		P 816201	5	3	6	2	277	21
	P 816107	24	8	63	14	579	18								

011000100

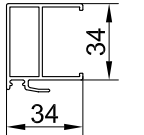
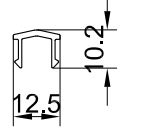
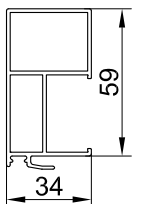
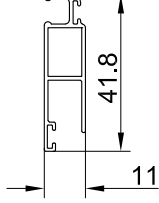
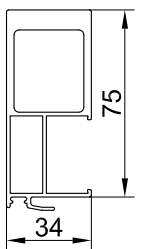
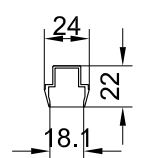
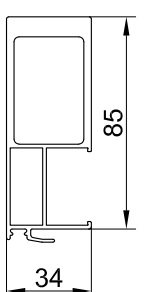
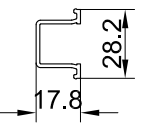
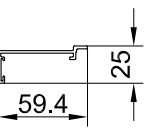
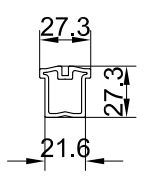
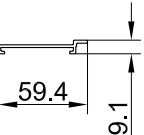
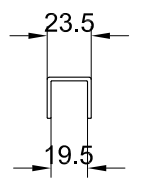
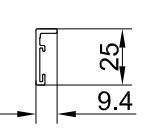
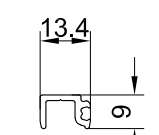
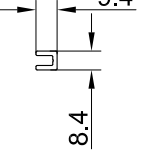
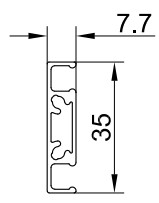
Profile overview and static profile values for Series Volato 30 NI

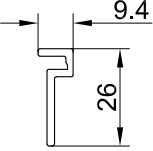
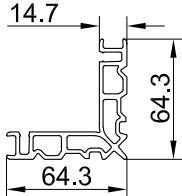
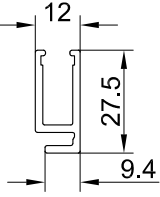
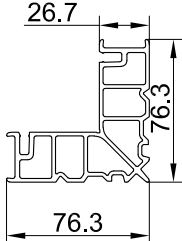
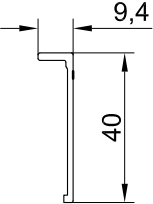
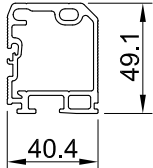
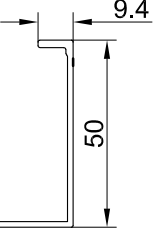
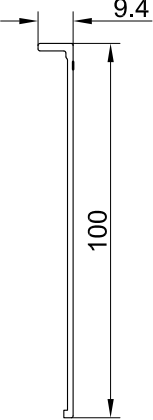

	Profile number	Horizontal axis		Vertical axis		External perimeter complete	Page		Profile number	Horizontal axis		Vertical axis		External perimeter complete	Page
		J_x (cm ⁴)	W_x (cm ³)	J_y (cm ⁴)	W_y (cm ³)					J_x (cm ⁴)	W_x (cm ³)	J_y (cm ⁴)	W_y (cm ³)		
	P 816202	5	2	2	1	214	22		P 816600	-	-	-	-	99	23
	P 816204	16	5	5	2	264	22		P 816601	-	-	-	-	166	23
	P 816205	46	9	10	5	296	22		P 816602	-	-	-	-	220	23
	P 816206	63	11	11	6	316	22		P 816605	-	-	-	-	126	21
	P 815601	7	2	1	0	197	25		P 816606	-	-	-	-	593	28
	P 815602	5	2	0	0	153	25		P 816607	-	-	-	-	129	23
	P 815604	0	0	0	0	85	25		P 815611	-	-	-	-	61	24
	P 815605	0	0	0	4	49	25		P 815623	1	1	0	0	111	23

Profile overview and static profile values for Series Volato 30 NI

	Profile number	Horizontal axis		Vertical axis		External perimeter complete	Page -		Profile number	Horizontal axis		Vertical axis		External perimeter complete	Page -
		J_x (cm ⁴)	W_x (cm ³)	J_y (cm ⁴)	W_y (cm ³)					J_x (cm ⁴)	W_x (cm ³)	J_y (cm ⁴)	W_y (cm ³)		
	P 815624	0	0	0	0	80	24		P 599343	24	6	24	6	350	26
	P 815625	1	1	0	0	136	24		P 599348	50	11	50	11	396	26
	P 815626	1	1	0	0	99	24		P 599362	16	6	10	5	229	27
	P 815627	4	1	0	0	154	24								
	P 815628	17	3	0	0	219	24								

013000300

Profile overview and static profile values for Series Volato 30 NI

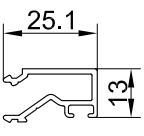
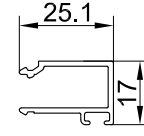
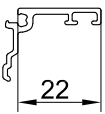
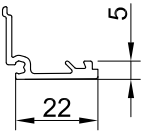
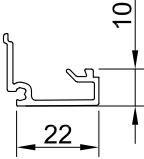
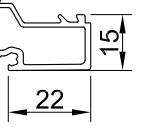
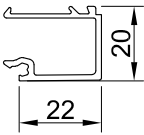
	Profile number	Horizontal axis		Vertical axis		External perimeter complete	Page		Profile number	Horizontal axis		Vertical axis		External perimeter complete	Page
		J_x (cm ⁴)	W_x (cm ³)	J_y (cm ⁴)	W_y (cm ³)					J_x (cm ⁴)	W_x (cm ³)	J_y (cm ⁴)	W_y (cm ³)		
	P 816603	-	-	-	-	144	31								
	P 816604	-	-	-	-	145	31								
	P 816608	-	-	-	-	208	31								
	P 815400	-	-	-	-	226	31								
	P 815401	-	-	-	-	245	31								
	P 494400	-	-	-	-	287	31								
	P 494401	-	-	-	-	295	31								

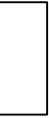

P 816101

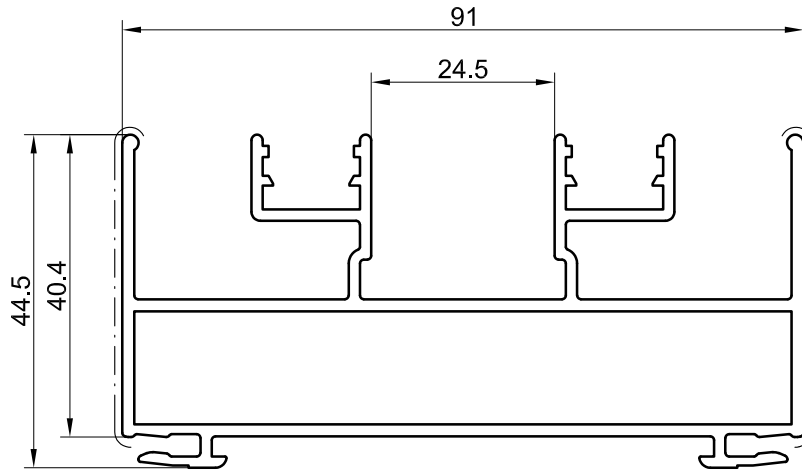

P 816104

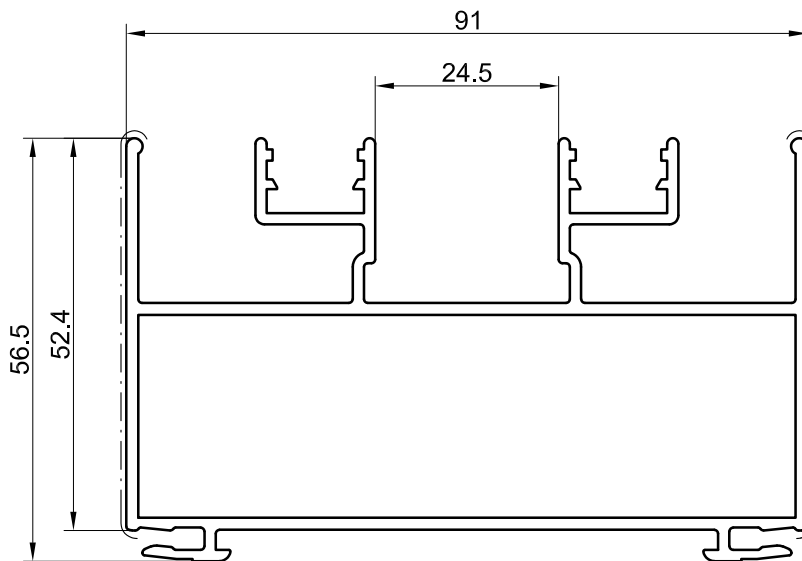

Scale 1:1

015000600

	chamber				
P 816101	-	Z 918393	4x Z 911049	Z 911187	-
P 816104	-	Z 918570	4x Z 911049	Z 911187	-





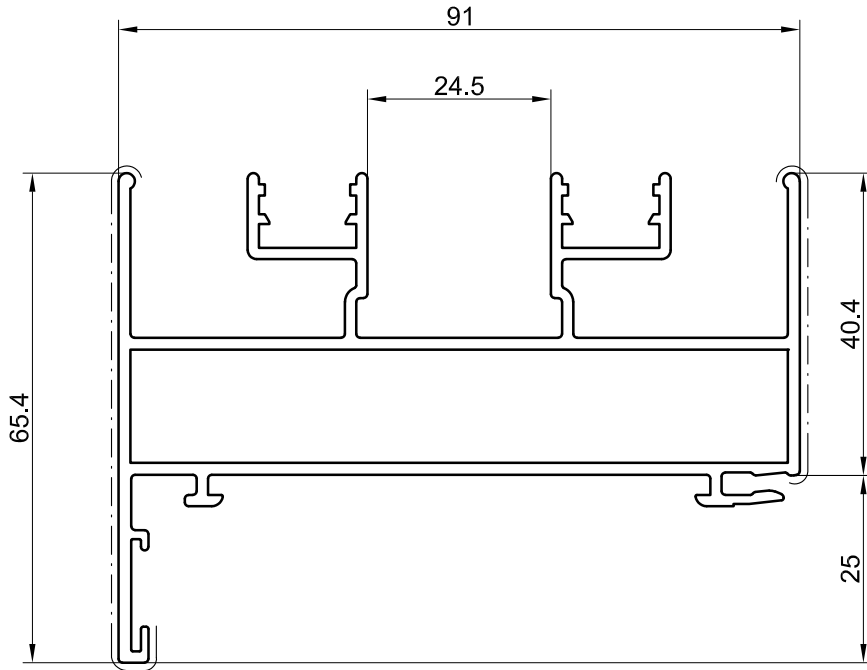



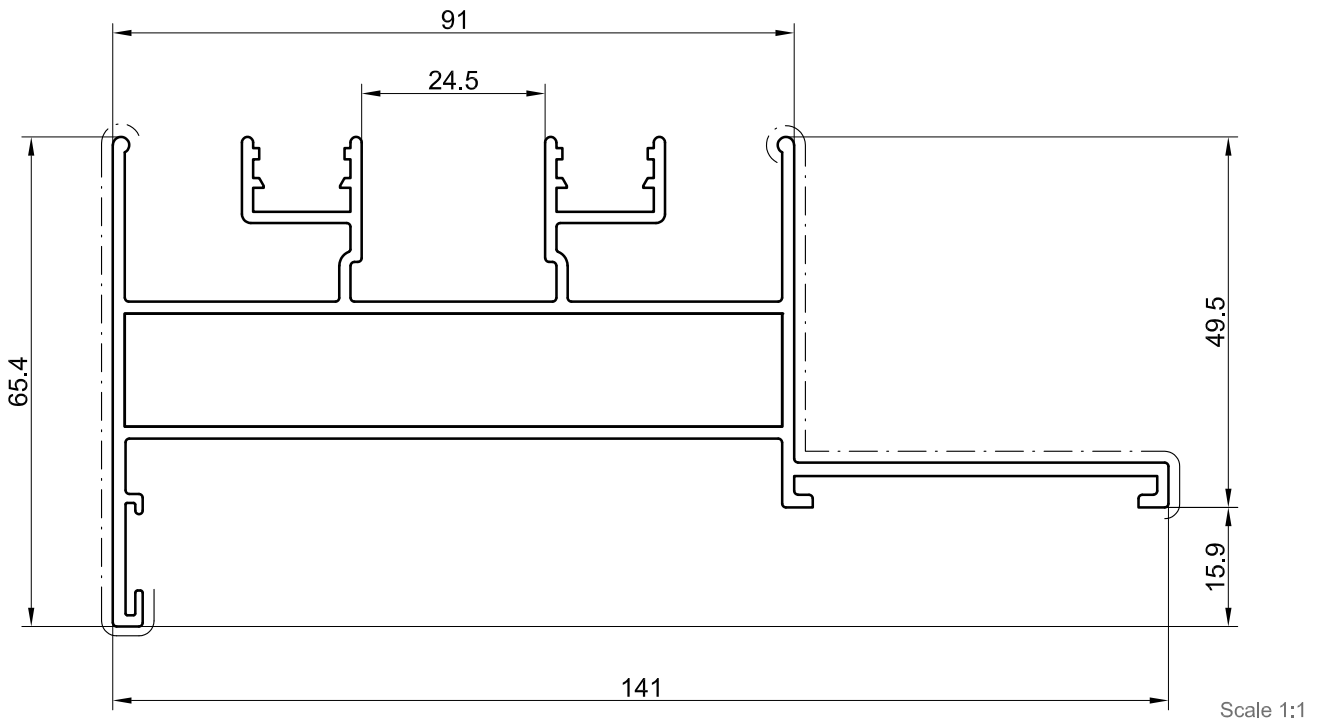

P 816102

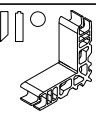

P 816103



<ul style="list-style-type: none">  crimpable  nailable  retro gluing after assembly 	chamber				
					
P 816102	-	Z 918393	4x Z 911049	Z 911187	-
P 816103	-	Z 918393	4x Z 911049	Z 911187	-

016000600

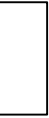

P 816105

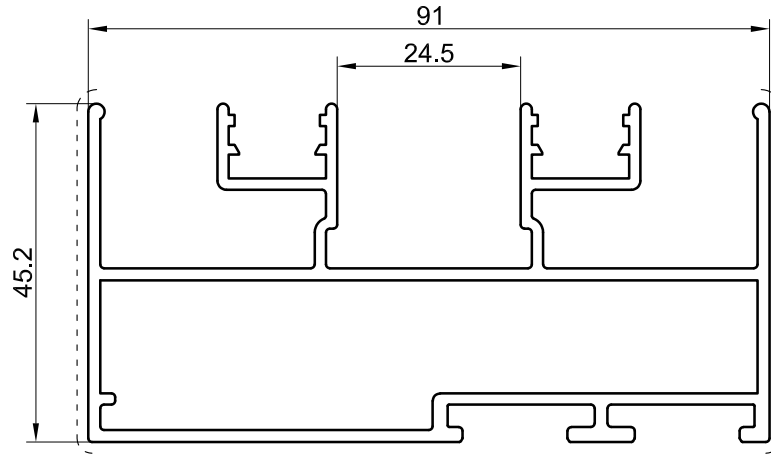

P 816106

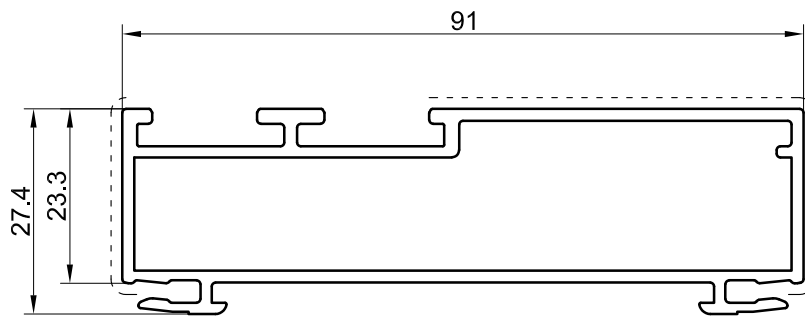

Scale 1:1

017000700

	chamber				
P 816105	-	Z 918393	4x Z 911049	Z 911187	-
P 816106	-	Z 918393	4x Z 911049	Z 911187	-





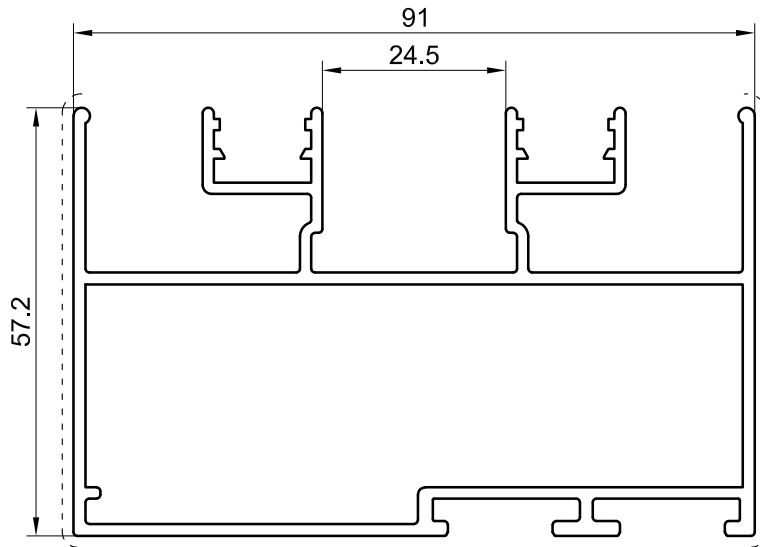



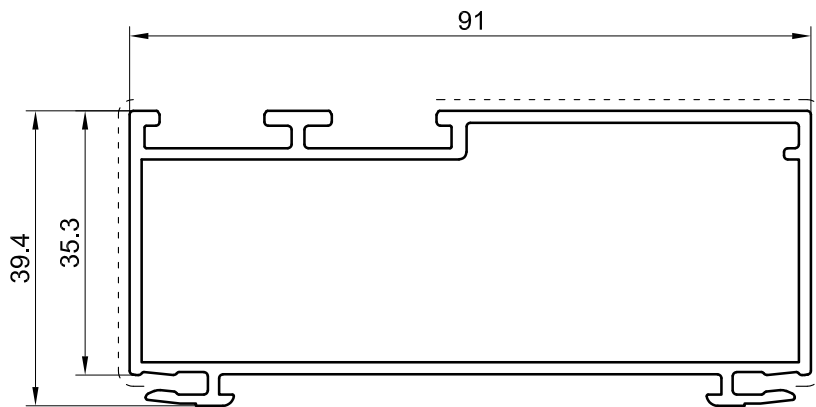

P 816107



P 816108

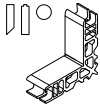

Scale 1:1

<ul style="list-style-type: none">  crimpable  nailable  retro gluing after assembly 	chamber				
					
P 816107	-	Z 918570	4x Z 911049	Z 911187	-
P 816108	-	Z 918570	4x Z 911049	Z 911187	-

018000800





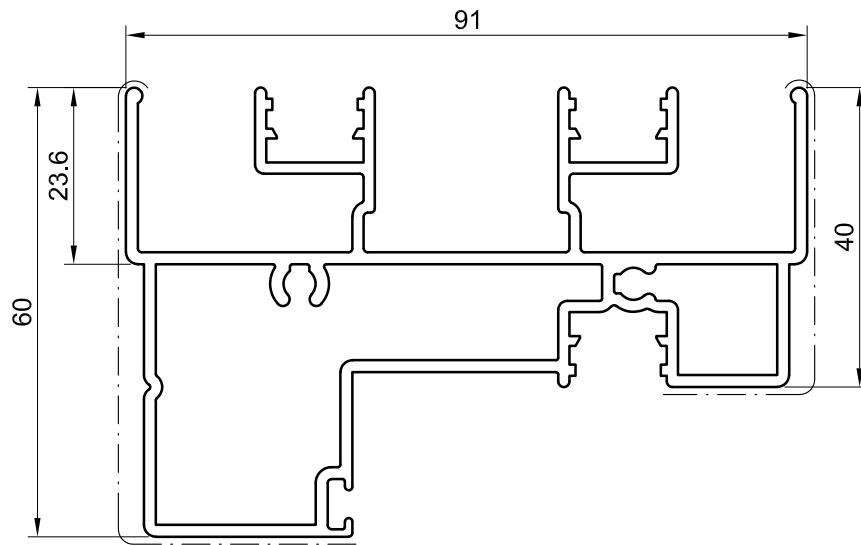





P 816300



Scale 1:1

019000900

<ul style="list-style-type: none">  crimpable  nailable  retro gluing after assembly 	chamber					
						
P 816300	-	-	-	-	-	-





P 816109

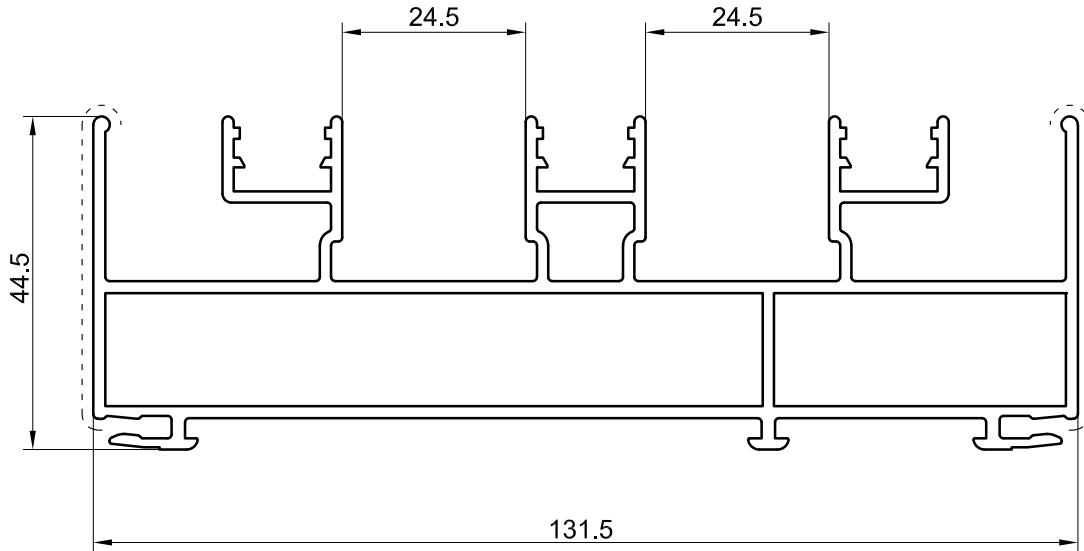

P 816110

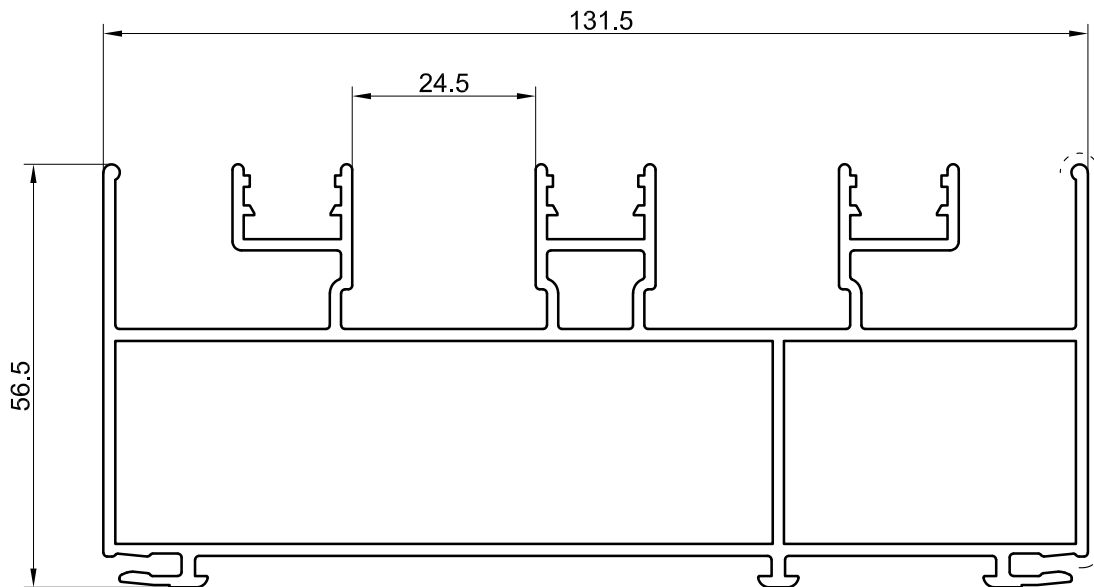

Scale 1:1

	chamber				
P 816109	-				
P 816110	-				

020000800



P 816605

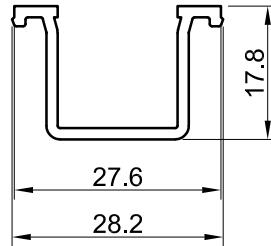

P 816200

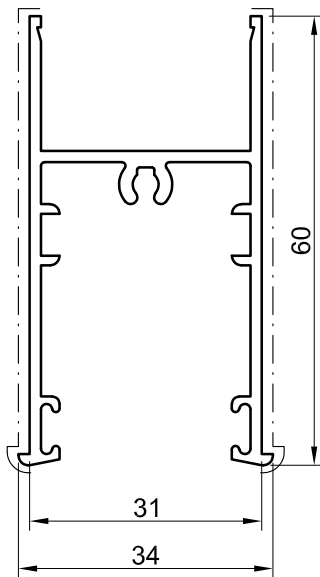

P 816201

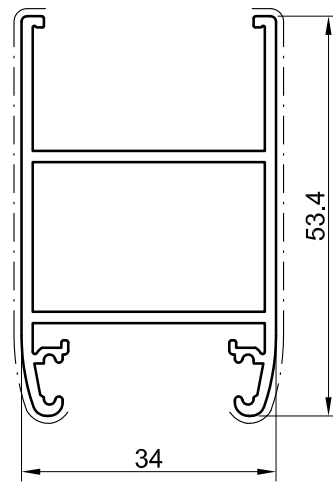

Scale 1:1

021001000

	crimpable	chamber				
P 816200	-	-	-	-	-	-
P 816201	-	-	-	-	-	-
P 816605	-	-	-	-	-	-





P 816202

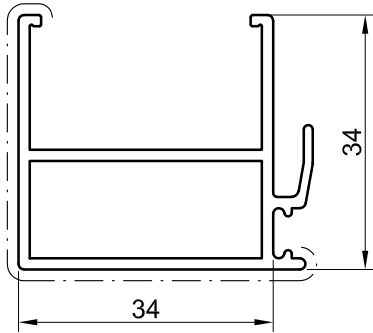

P 816204

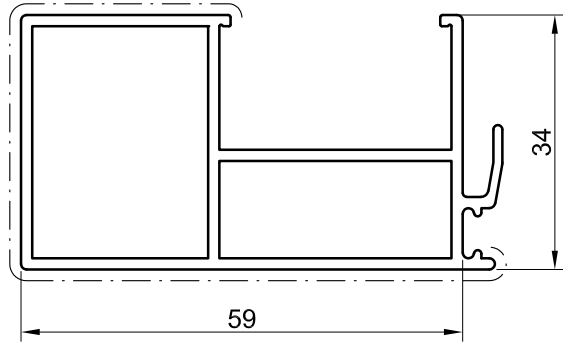



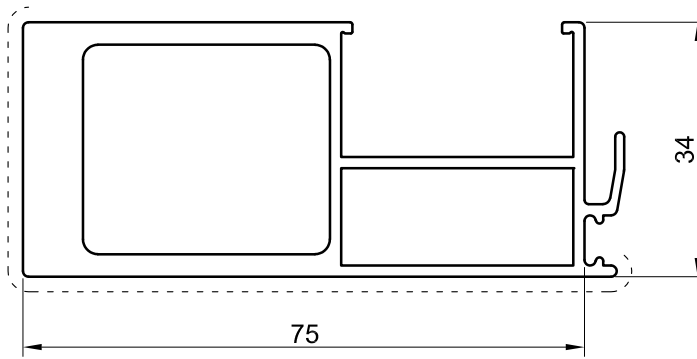

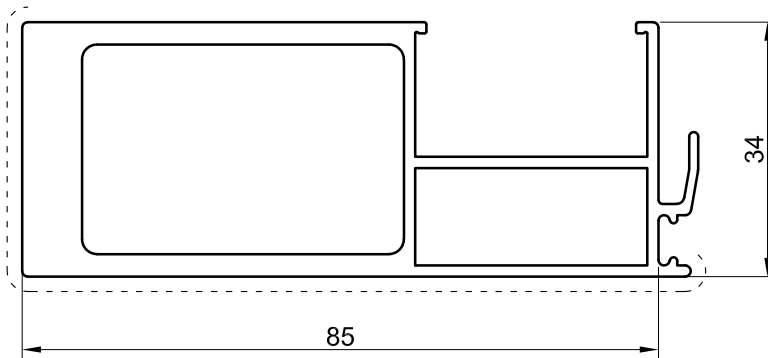

P 816205



P 816206

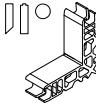

Scale 1:1

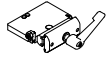
<ul style="list-style-type: none">  crimpable  nailable  retro gluing after assembly 	chamber				
					
P 816202	-	-	-	-	-
P 816204	-	-	-	-	-
P 816205	-	-	-	-	-
P 816206	-	-	-	-	-

022001000

P 816600

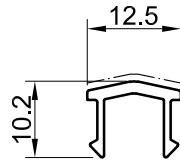

P 816602

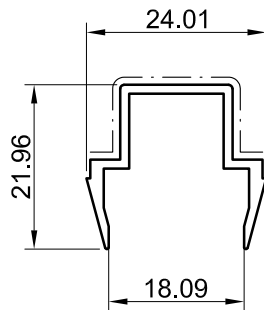

P 816607

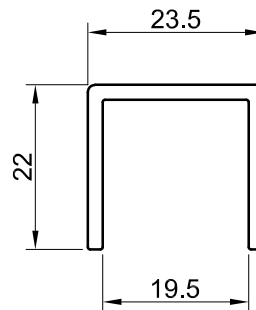

P 816601

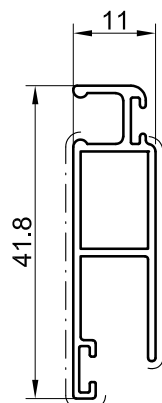

P 815623

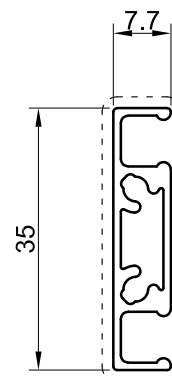

023001100

Scale 1:1

P 815626

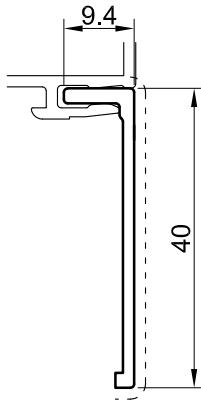

P 815627

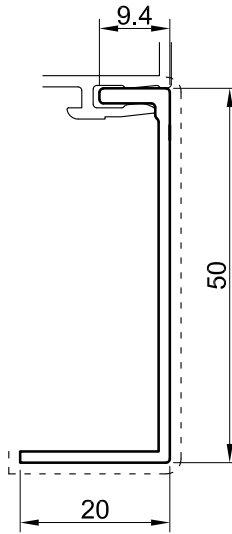

P 815628

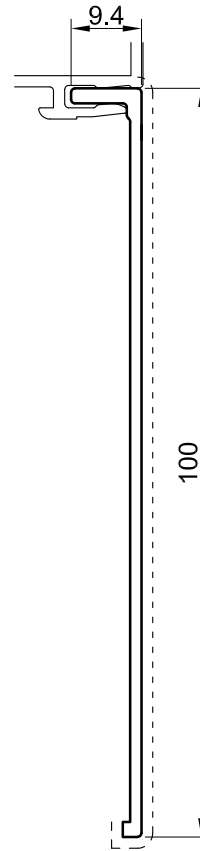

P 815624

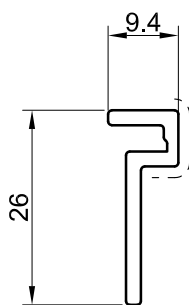

P 815625

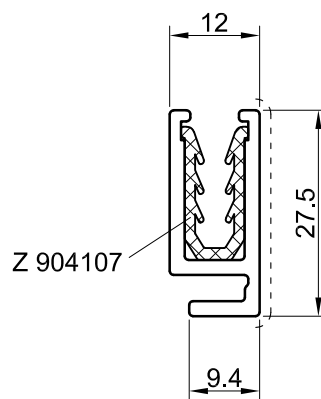

P 815611

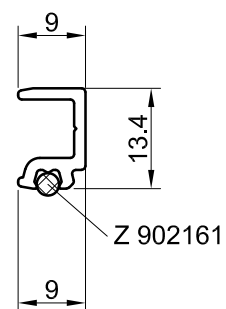

Scale 1:1

P 815604

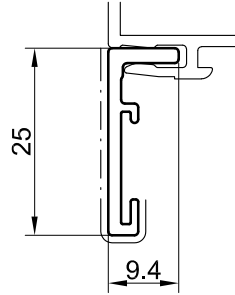

P 815605

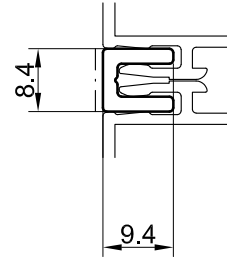

P 815601

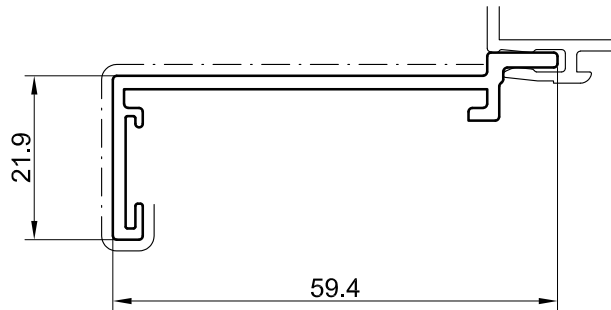

P 815602

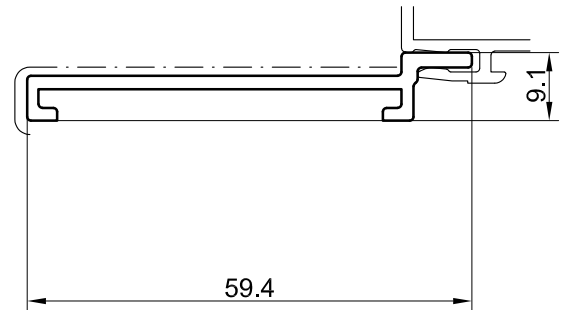

025001300

Scale 1:1



P 599343

article no.:	profile no.:	length
Z918393	P599343	87,3 mm
Z923071	P599343	38,5 mm

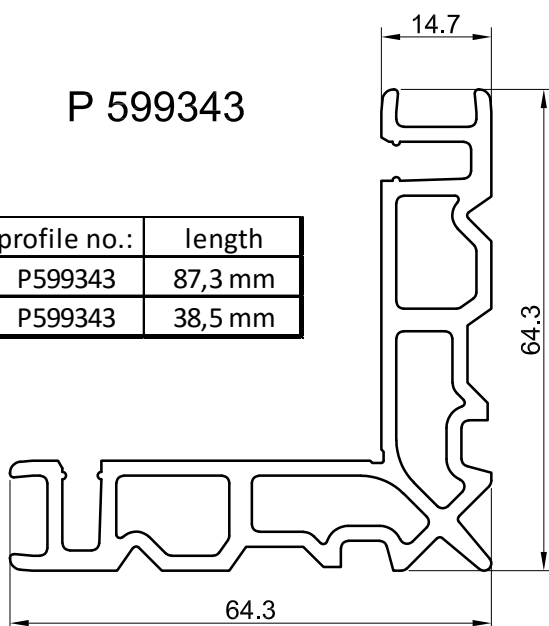

P 599348

article no.:	profile no.:	length
Z918570	P599348	87,3 mm
Z923072	P599348	38,5 mm

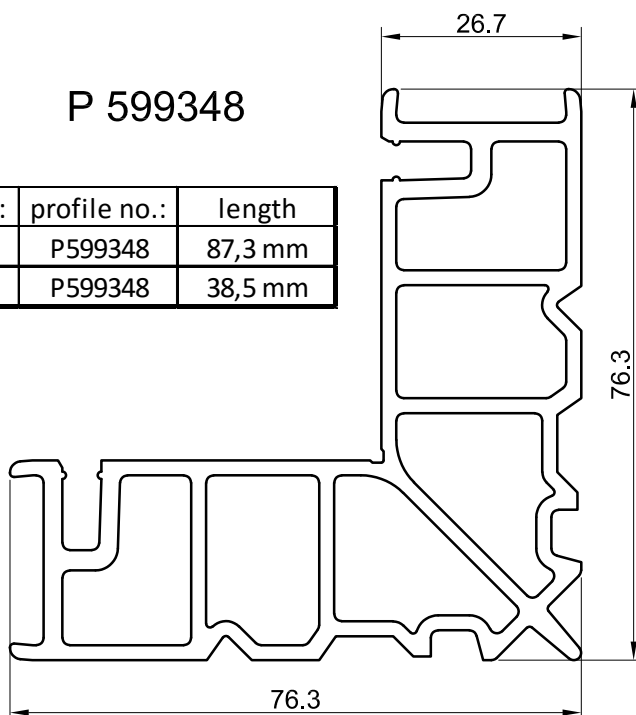

Scale 1:1

P 599362

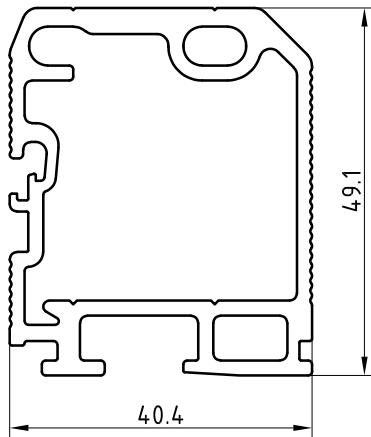

article no.:	profile no.:	length (X)	gasket	screw
Z918502	P599362	14,7 mm	Z914288	2 x 917691

mounted from :

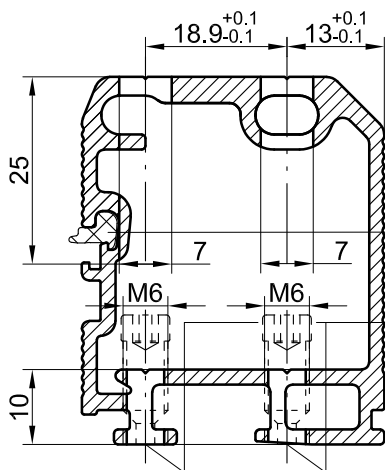

*

- silicon gasket strip Z914288 is to be:
- cut to fit
- joined in
- secure against inadvertent movement

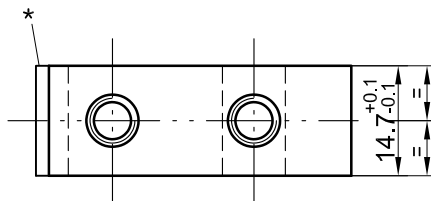

- punch screw M6 art.-no. 2 x Z917691 is to be:
- flush screwed

027001500

Scale 1:1



P 816606

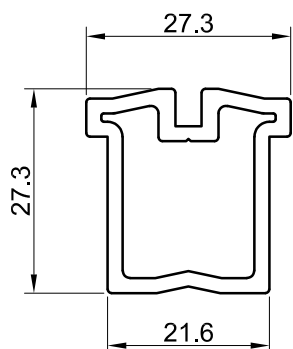

article no.:	profile no.:	length	screw
Z918566	P816606	60 mm	2 x 901853

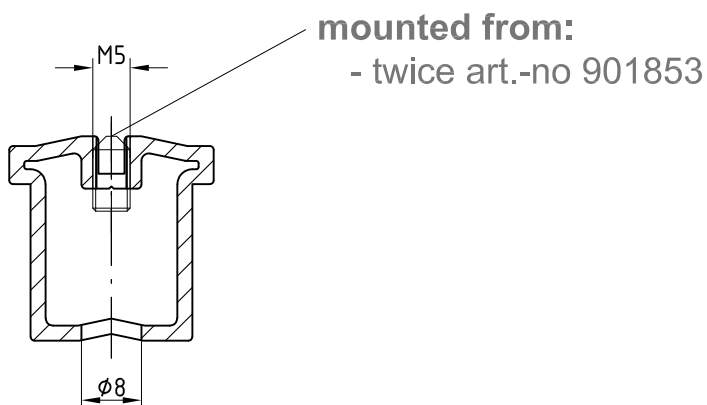

mounted from:
- twice art.-no 901853

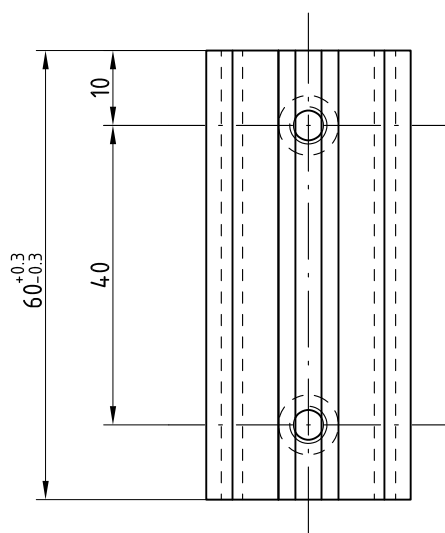

Scale 1:1

P 815400

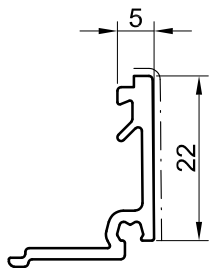

P 815401

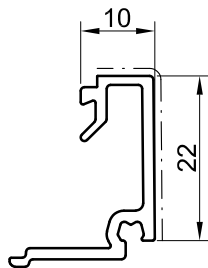

P 494400

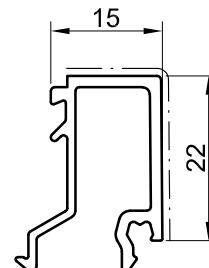

P 494401

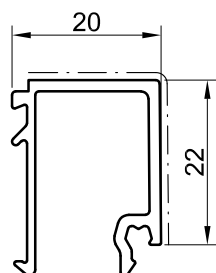

P 816608

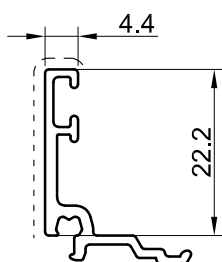

P 816603

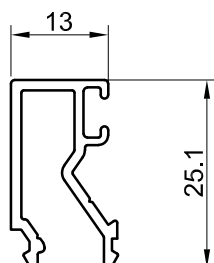

P 816604

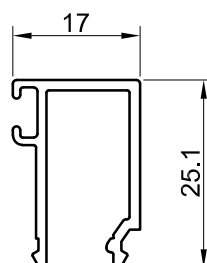

031000100

Scale 1:1



Glazing gasket	Glass thickness in mm	Variants of profiles
Z 918594	6	
Z 918597	8	
Z 918596	10	
Z 918595	12	

032000200

The specified panel thicknesses are nominal dimensions. When selecting the inner gasket, glass- and profile tolerances must be regarded. Possibly the next smaller or bigger inner gasket should be included.

Glazing gasket	Glass thickness in mm	Variants of profiles
Z 918593	20	
Z 918592	22	
Z 918378	24	

033000300

The specified panel thicknesses are nominal dimensions. When selecting the inner gasket, glass- and profile tolerances must be regarded. Possibly the next smaller or bigger inner gasket should be included.

Glazing gasket	Glass thickness in mm	Variants of profiles
Z 918727	6	
Z 918728	8	
Z 918729	10	
Z 918730	12	

034000400

The specified panel thicknesses are nominal dimensions. When selecting the inner gasket, glass- and profile tolerances must be regarded. Possibly the next smaller or bigger inner gasket should be included.

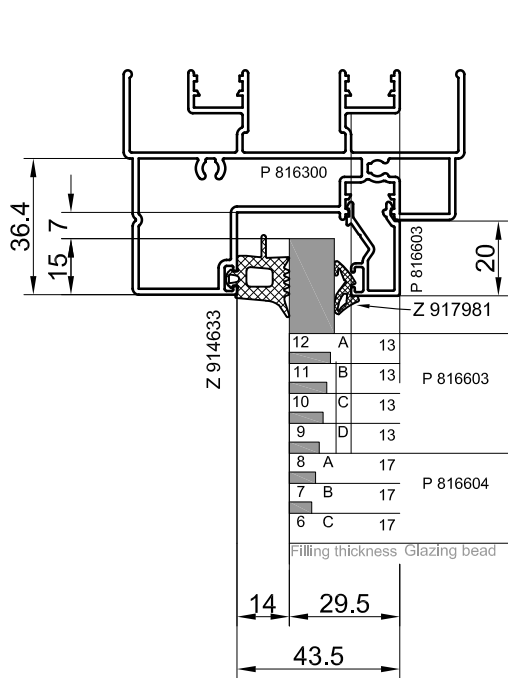

P 816603

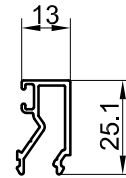

P 816604

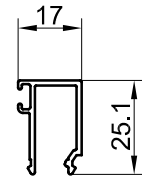

Glazing gaskets for glazing beads

Glazing gaskets	external	internal			
		(A)	(B)	(C)	(D)
Art. no.	Z 914633	Z 917981	Z 914259	Z 914260	Z 914261
Gap dimension	14	3.5 - 5.5	4.5 - 6.5	5.5 - 7.5	6.5 - 9.5

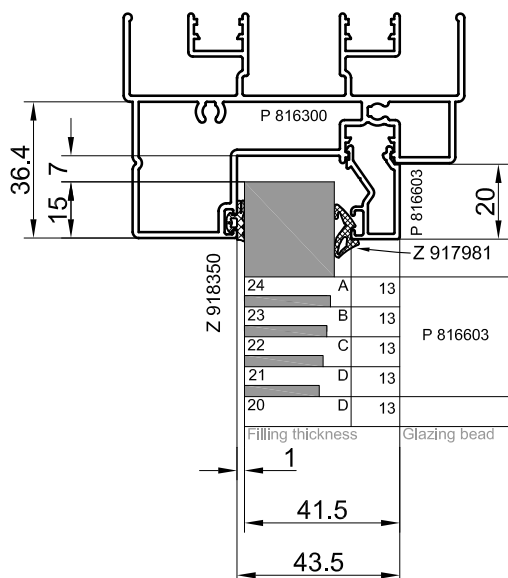

Glazing gaskets for glazing beads

Glazing gaskets	external	internal			
		(A)	(B)	(C)	(D)
Art. no.	Z 918350	Z 917981	Z 914259	Z 914260	Z 914261
Gap dimension	2	3.5 - 5.5	4.5 - 6.5	5.5 - 7.5	6.5 - 9.5

035000500

The specified panel thicknesses are nominal dimensions. When selecting the inner gasket, glass- and profile tolerances must be regarded. Possibly the next smaller or bigger inner gasket should be included.

Scale 1:2

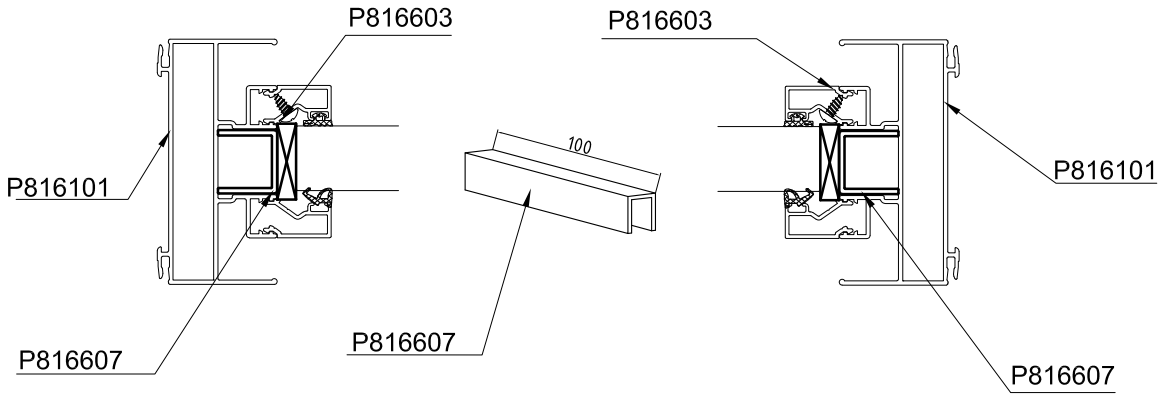
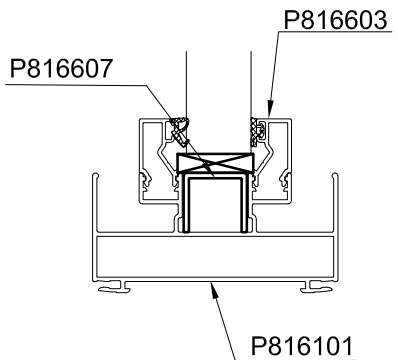
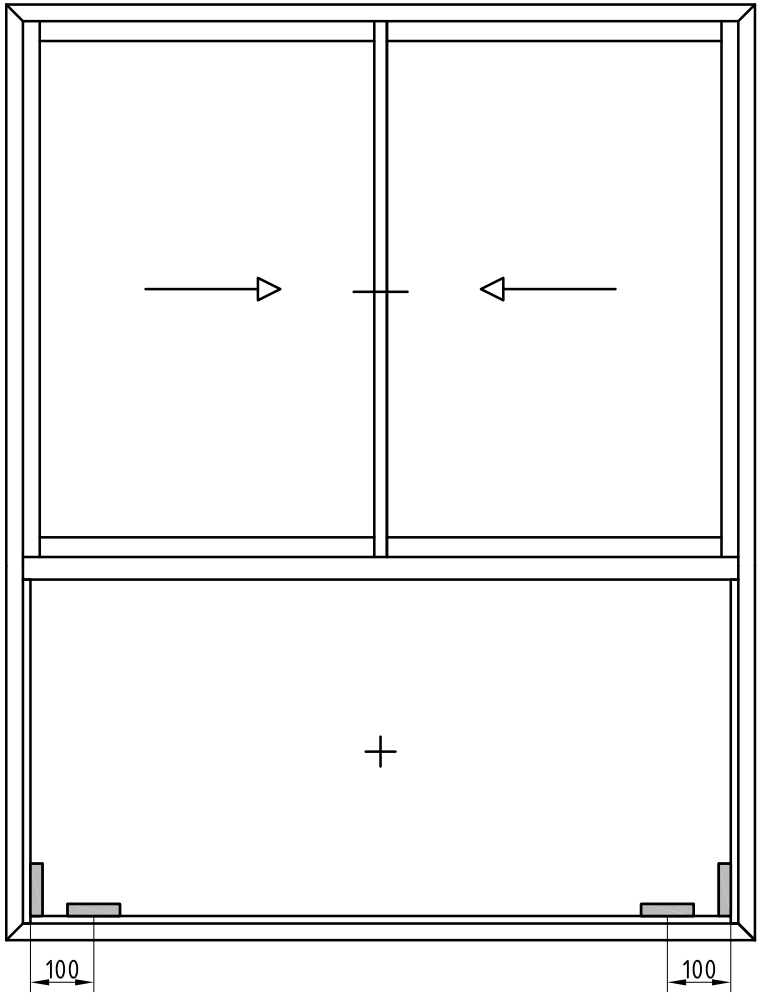

036000600

P 816608

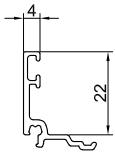

P 815400

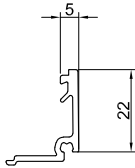

P 815401

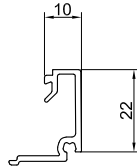



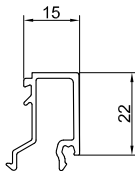

P 494400

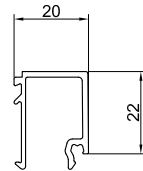

P 494401



Glazing gaskets for glazing beads

Glazing gaskets	external	internal			
		(A) 	(B) 	(C) 	(D) 
Art. no.	Z 914258	Z 917981	Z 914259	Z 914260	Z 914261
Gap dimension	5.5	3.5 - 5.5	4.5 - 6.5	5.5 - 7.5	6.5 - 9.5

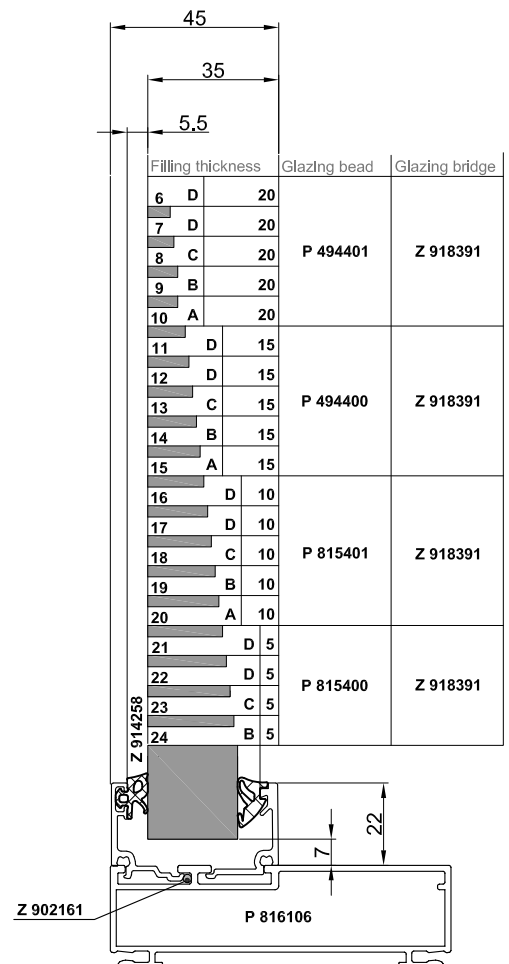

037000700

The specified panel thicknesses are nominal dimensions. When selecting the inner gasket, glass- and profile tolerances must be regarded. Possibly the next smaller or bigger inner gasket should be included.

Scale 1:2

for Frame 816101 / P 816109

all Scheme Glass height = B - 169 mm

Scheme A Glass width = A / 2 - 80,5 mm

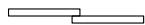

Scheme B + C Glass width = A / 4 - 63,2 mm



Scheme D Glass width = A / 3 - 56,4 mm

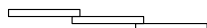

for Frame 816104 / P 816110

all Scheme Glass height = B - 193 mm

Scheme A Glass width = A / 2 - 92,5 mm

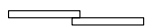

Scheme B + C Glass width = A / 4 - 69,2 mm

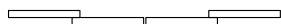

Scheme D Glass width = A / 3 - 64,4 mm



B = frame height

A = frame width

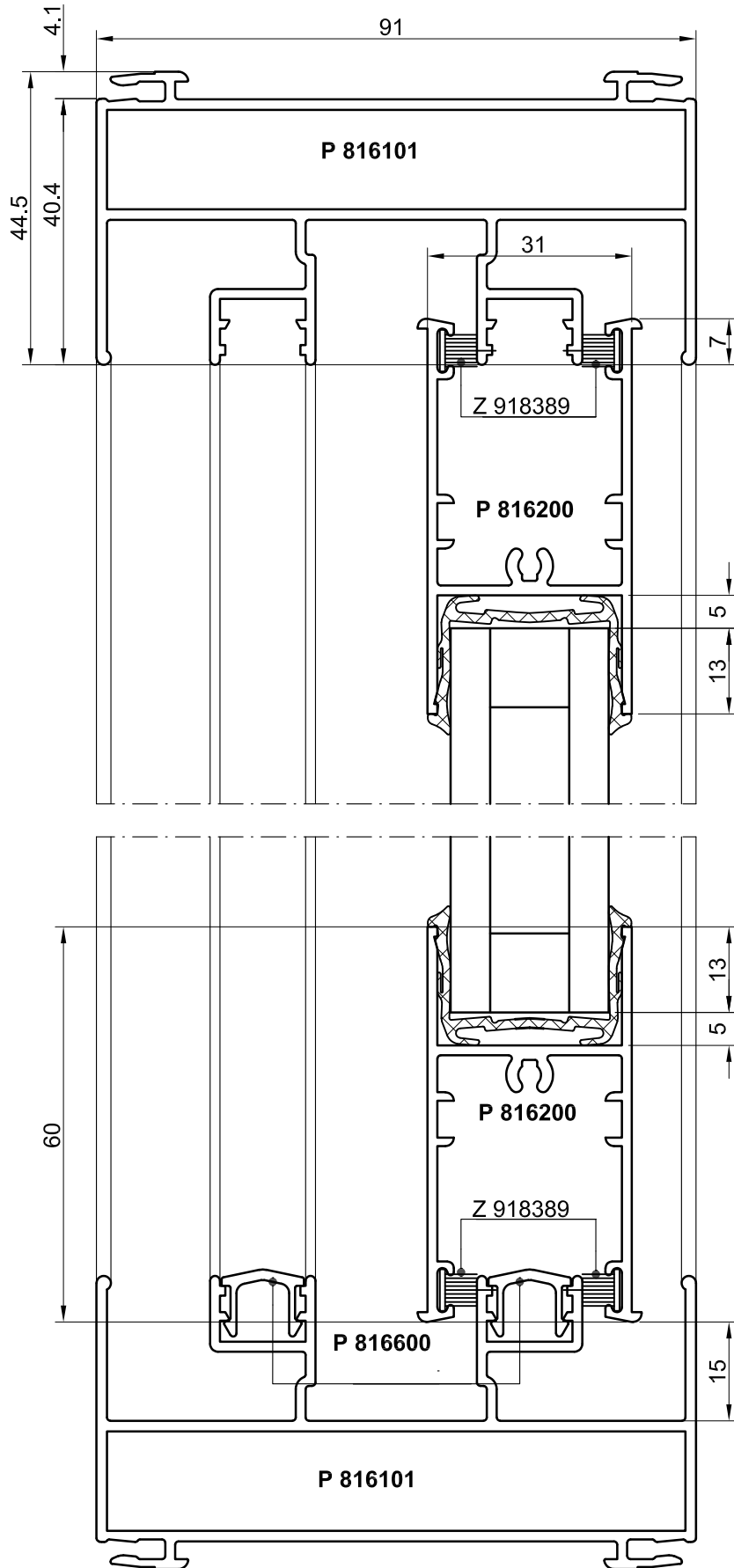
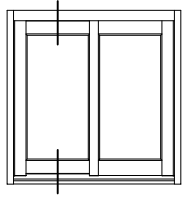

see glazing table

041000100

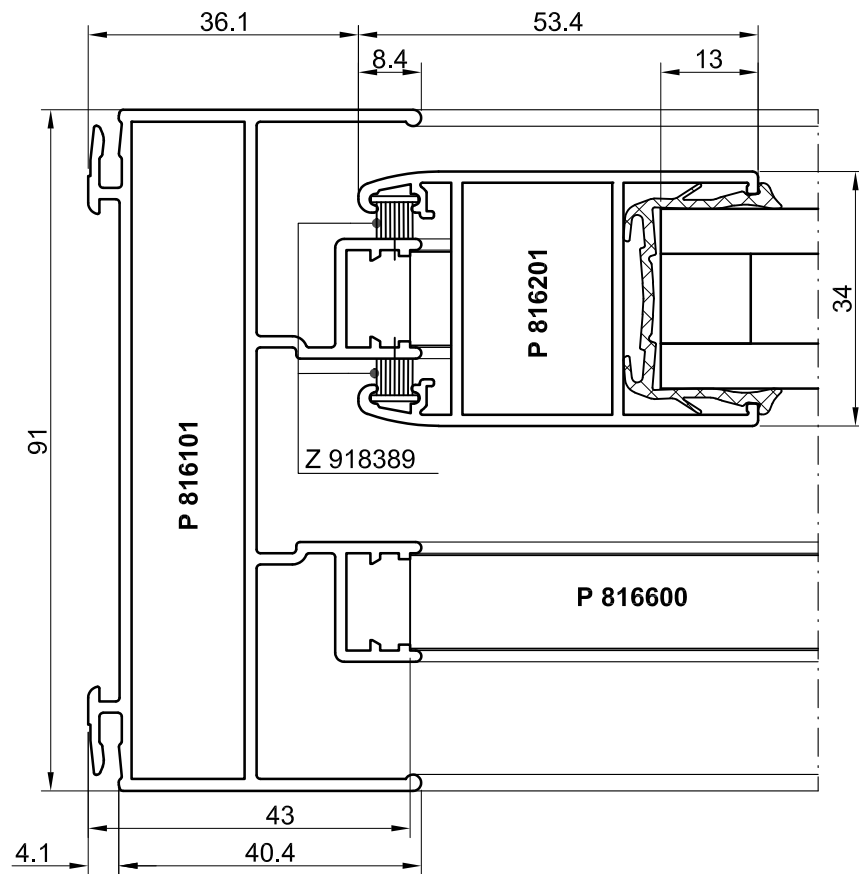
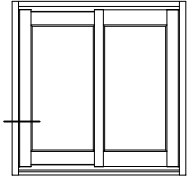

see glazing table

043000300

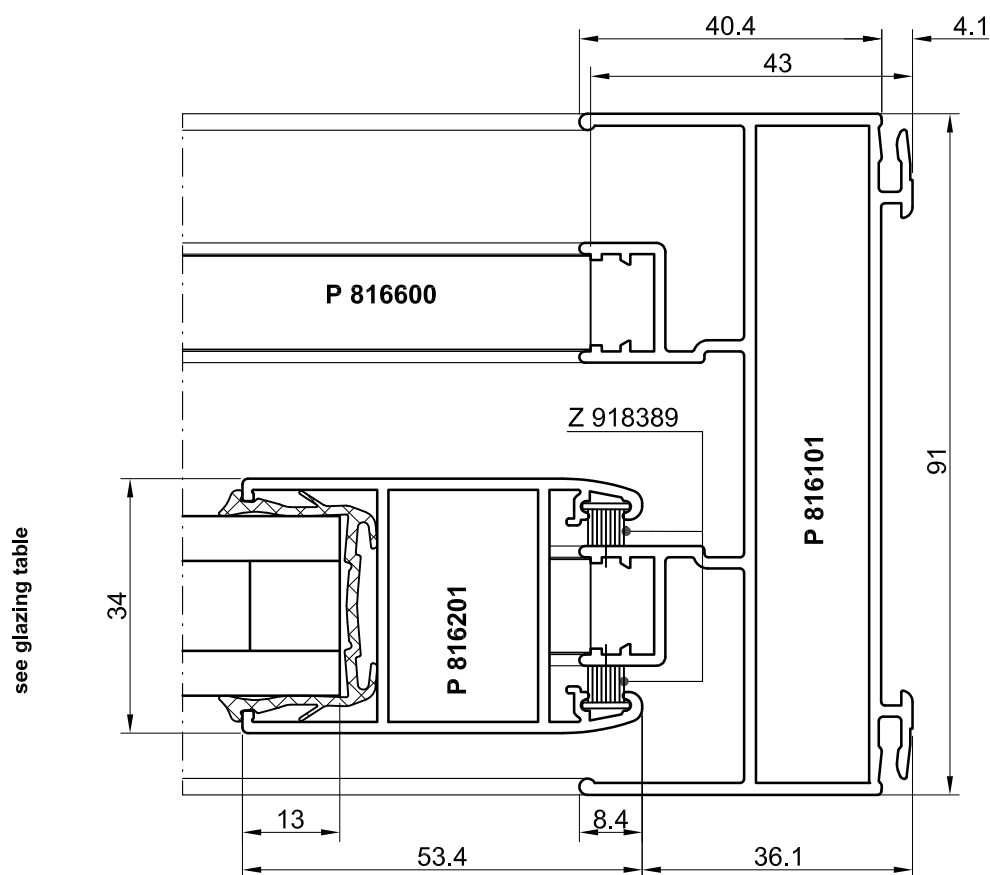
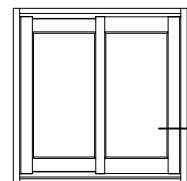

044000400

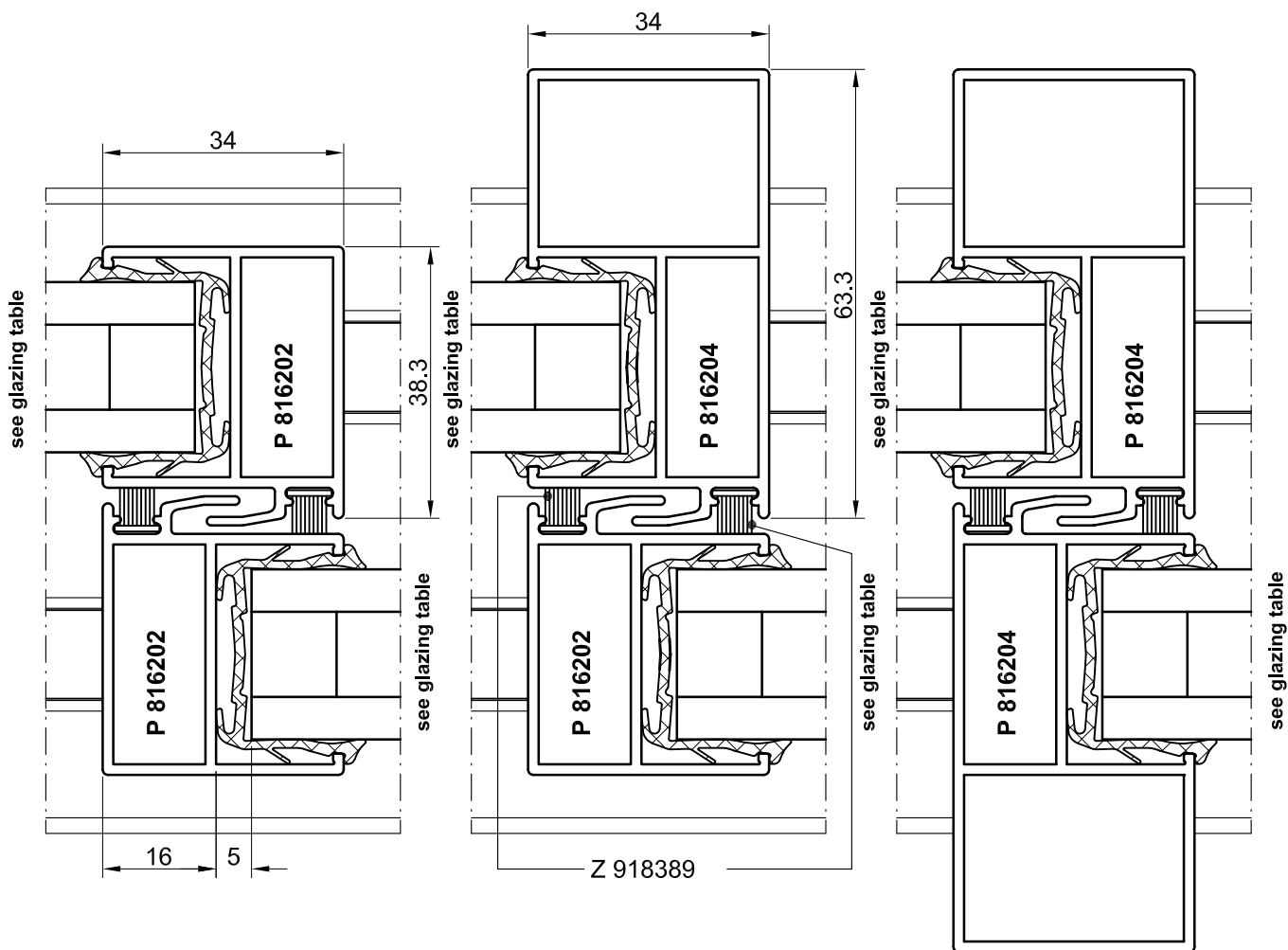
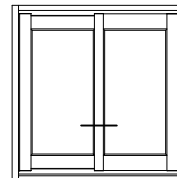

045006500



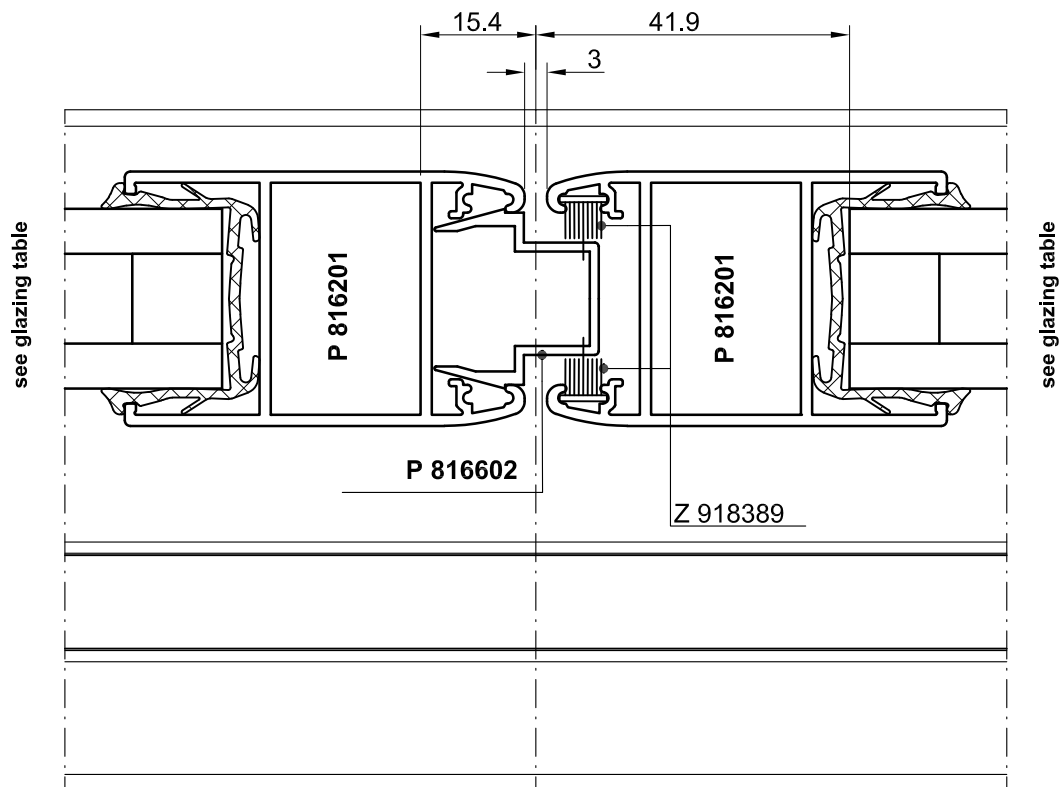
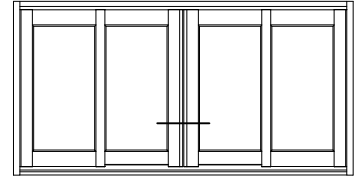

046000600

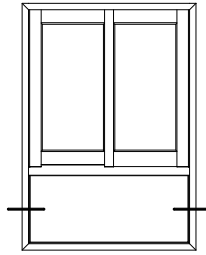

see glazing table

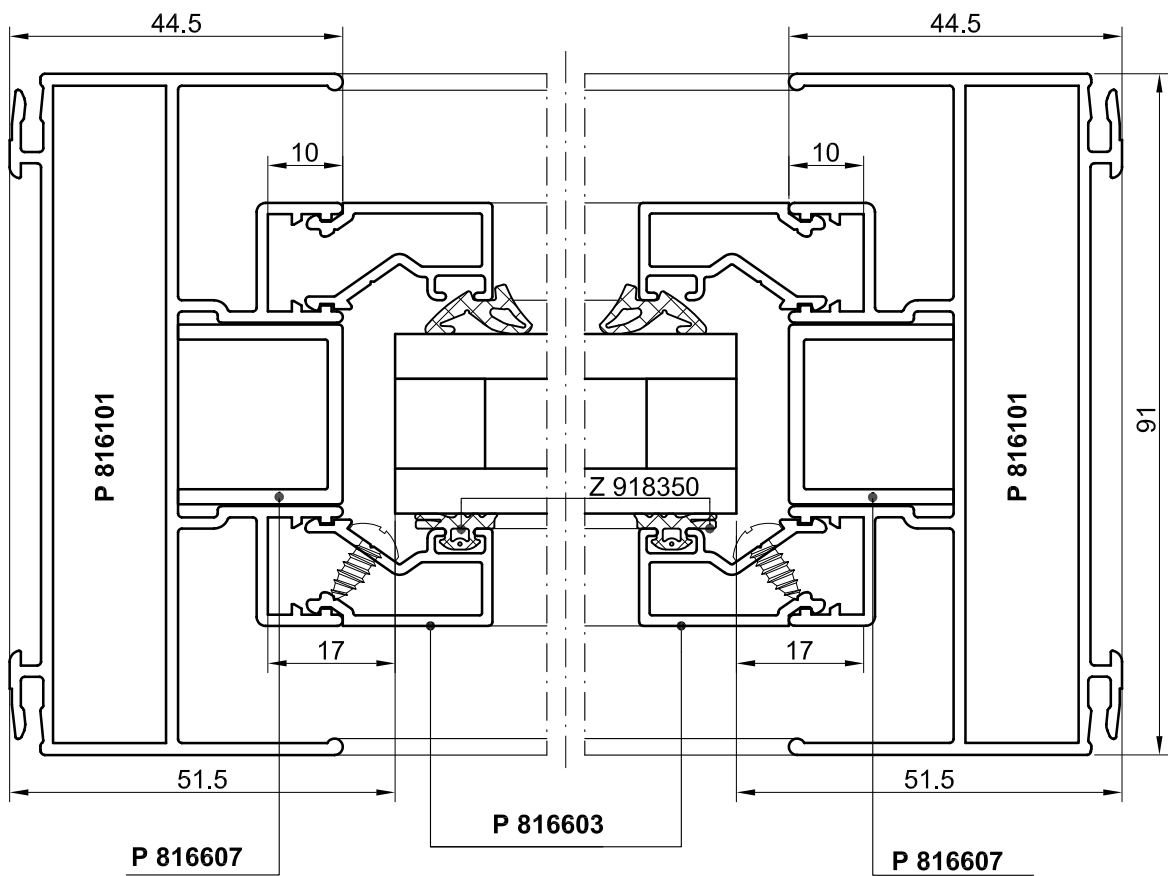

047000700

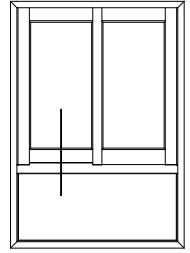

see glazing table

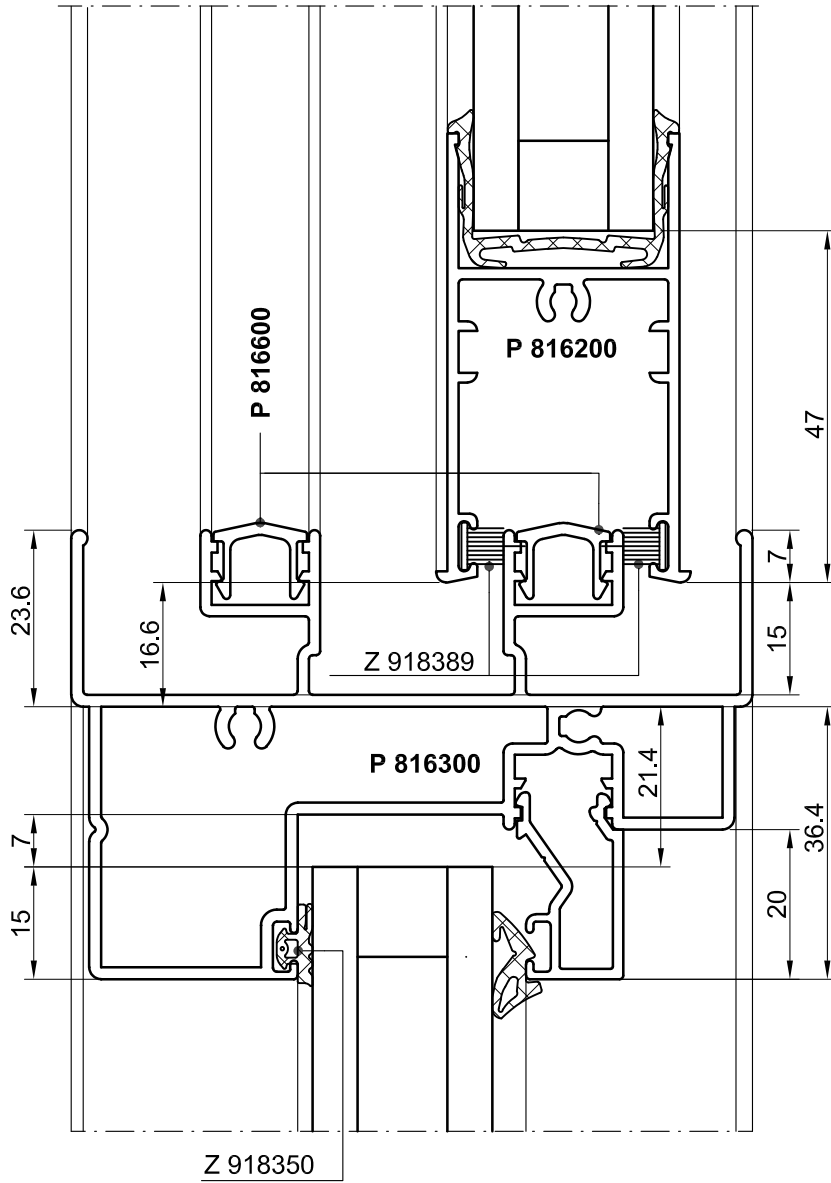

see glazing table

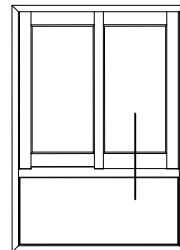

see glazing table

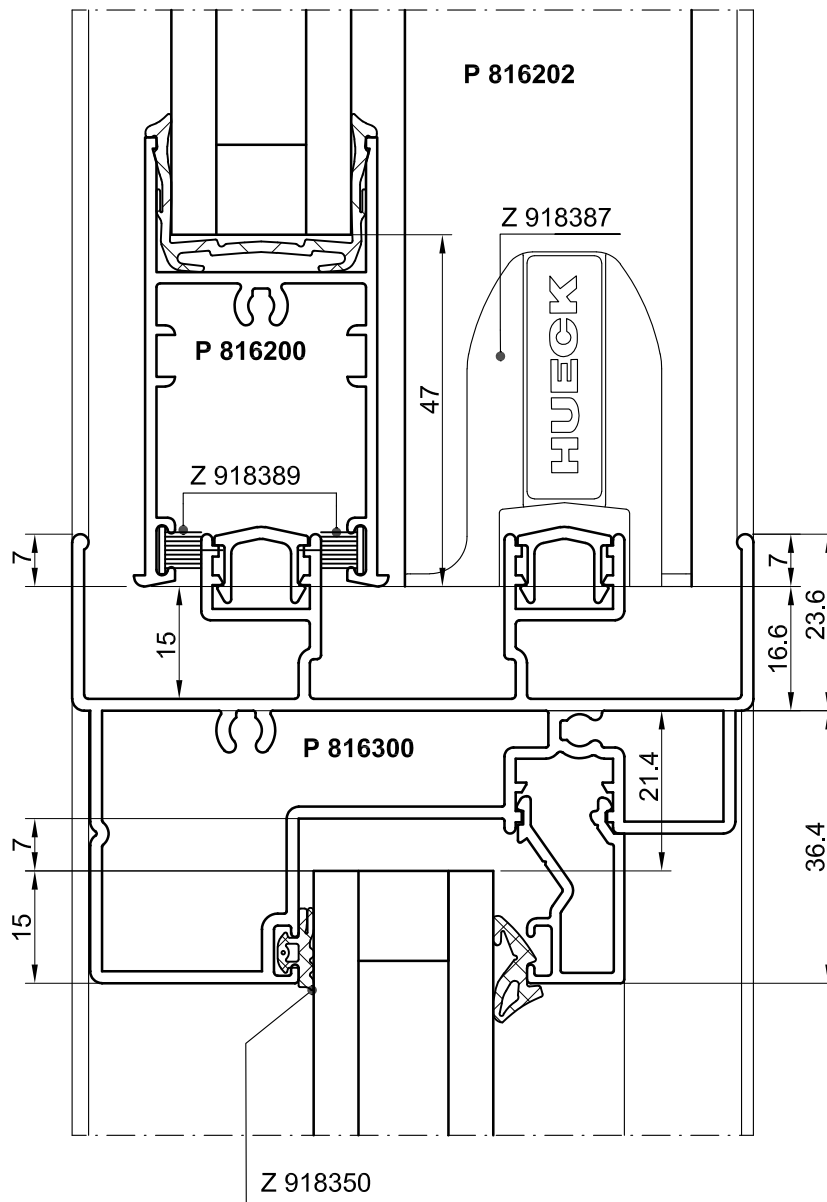

see glazing table

049000900

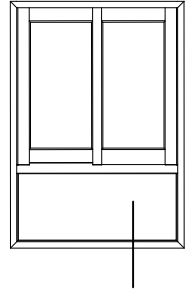

see glazing table

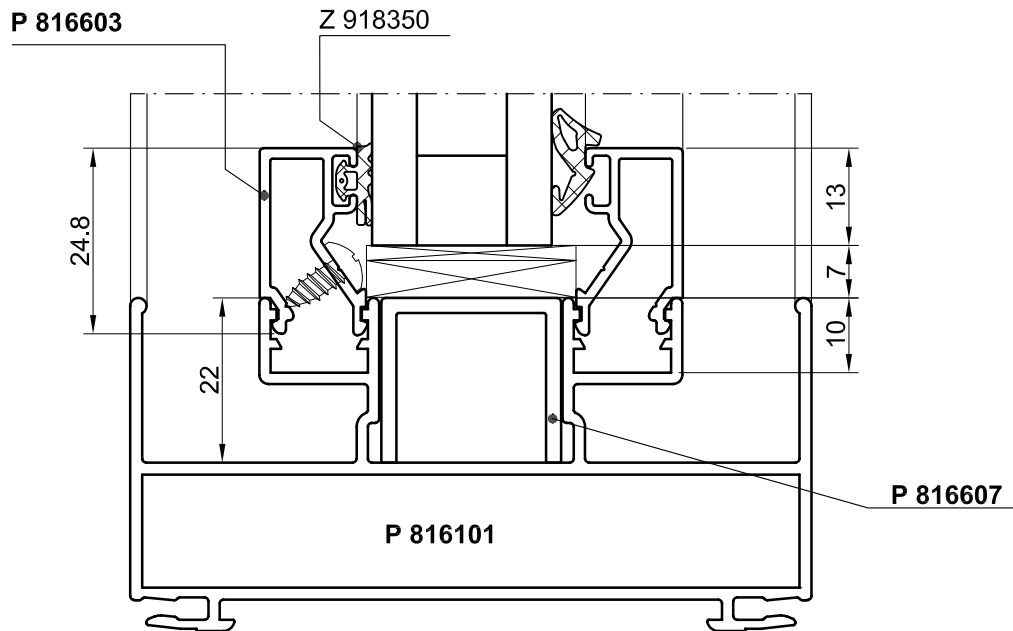

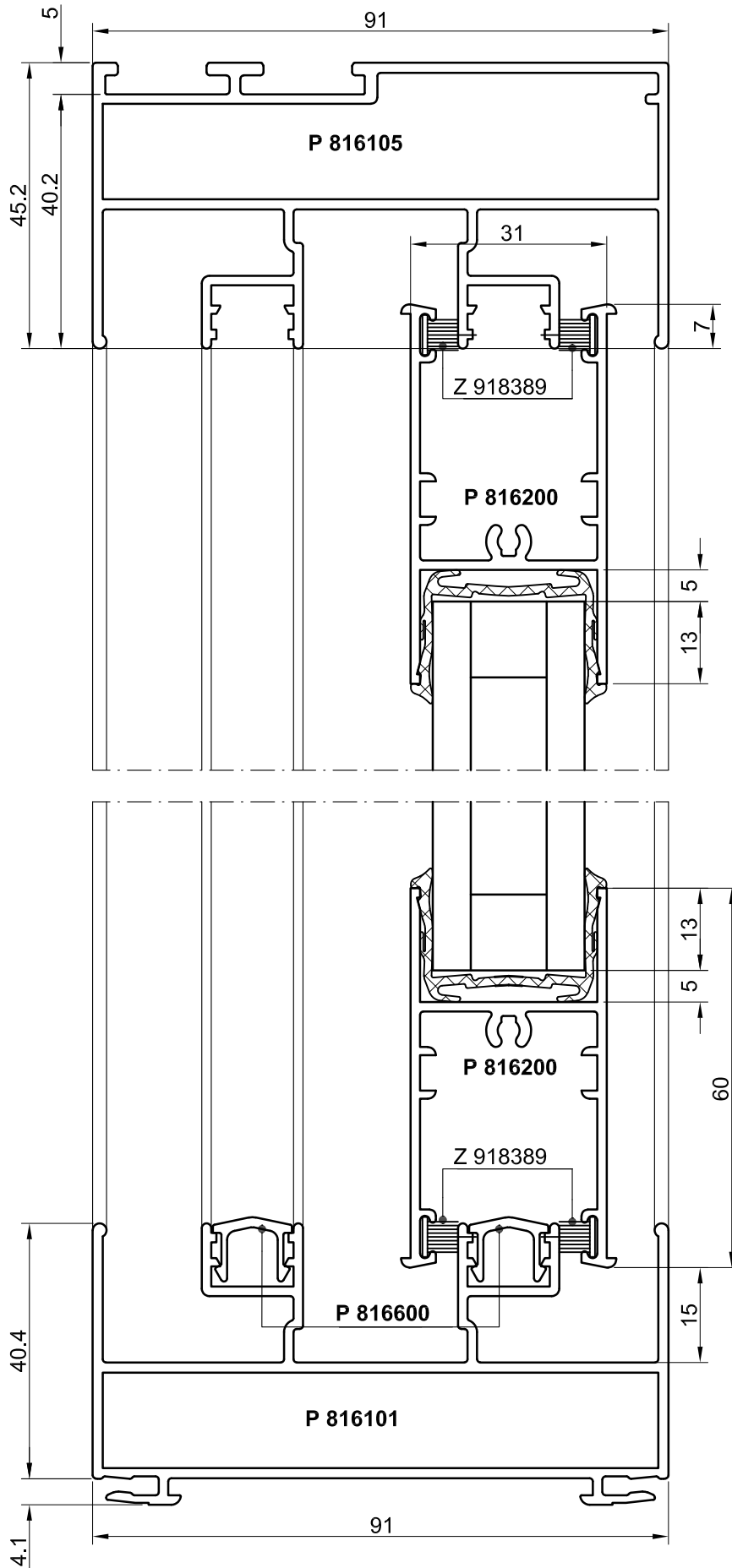
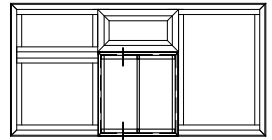

see glazing table

051001100

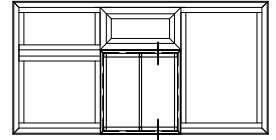
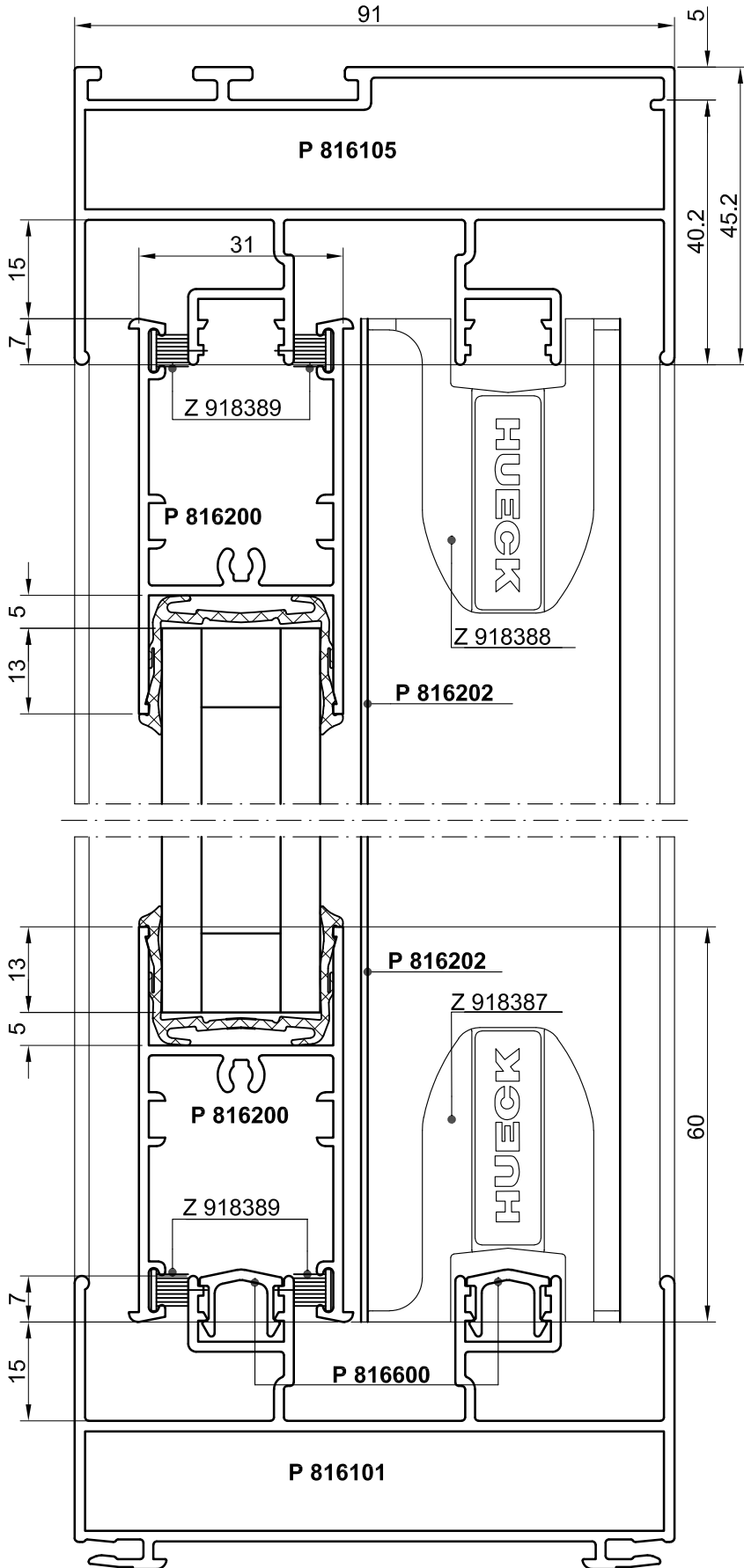

see glazing table

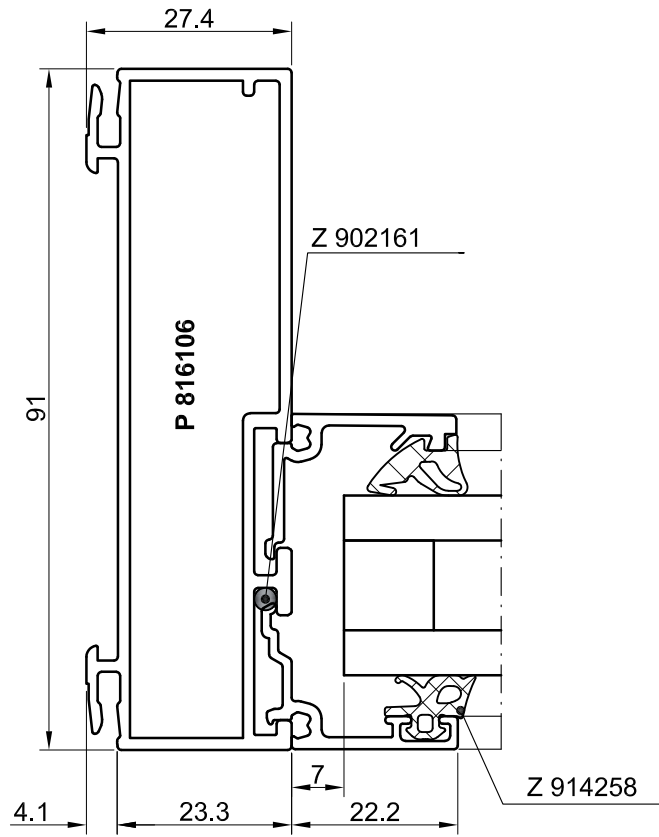
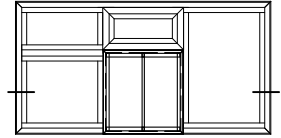

see glazing table

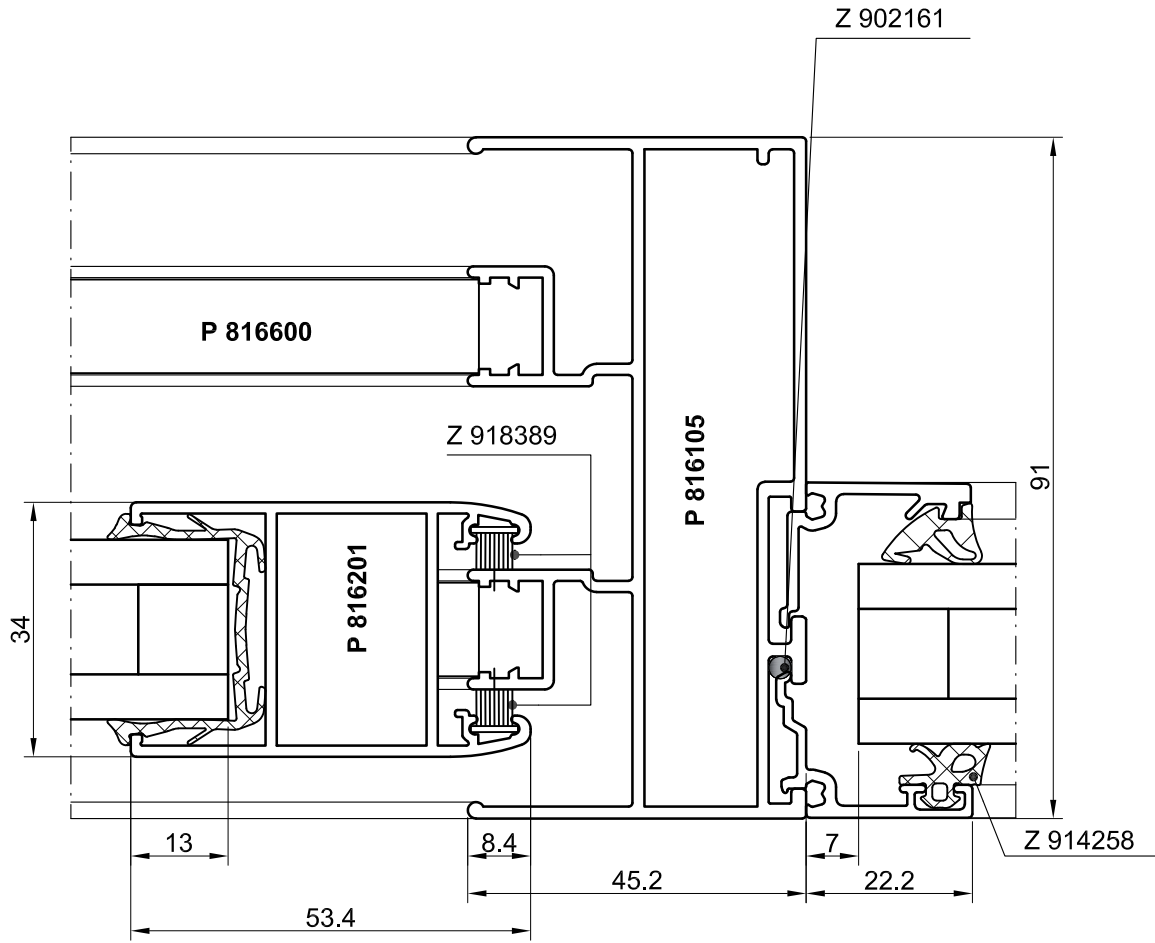
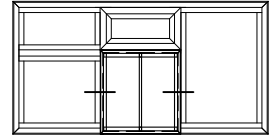

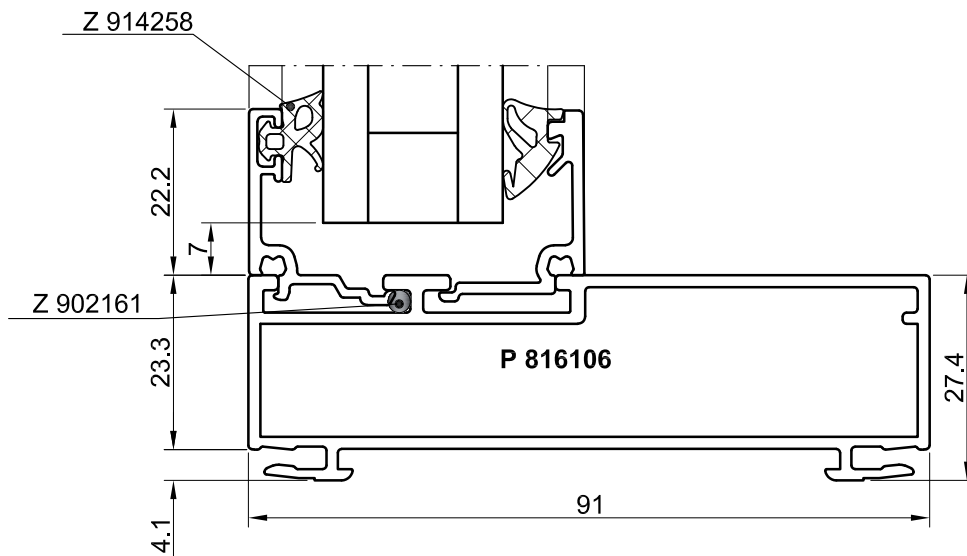
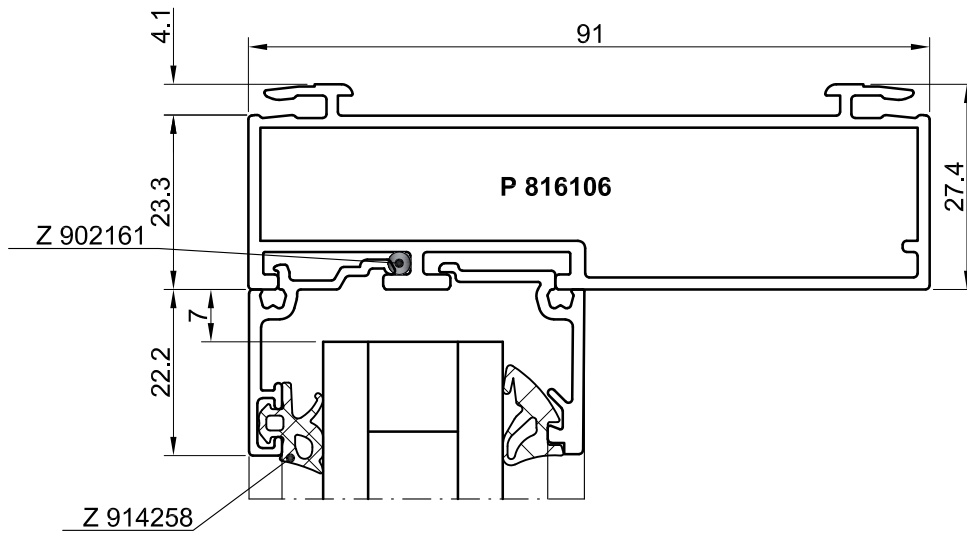
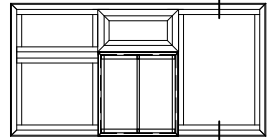

055001500

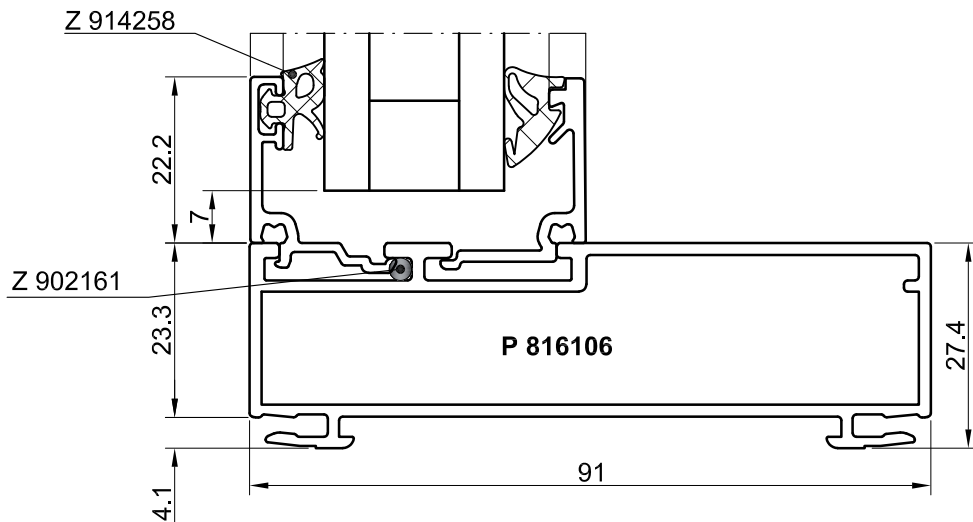
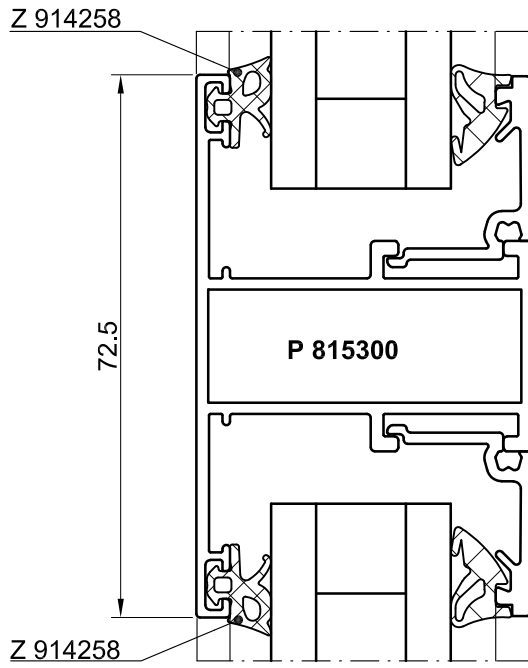
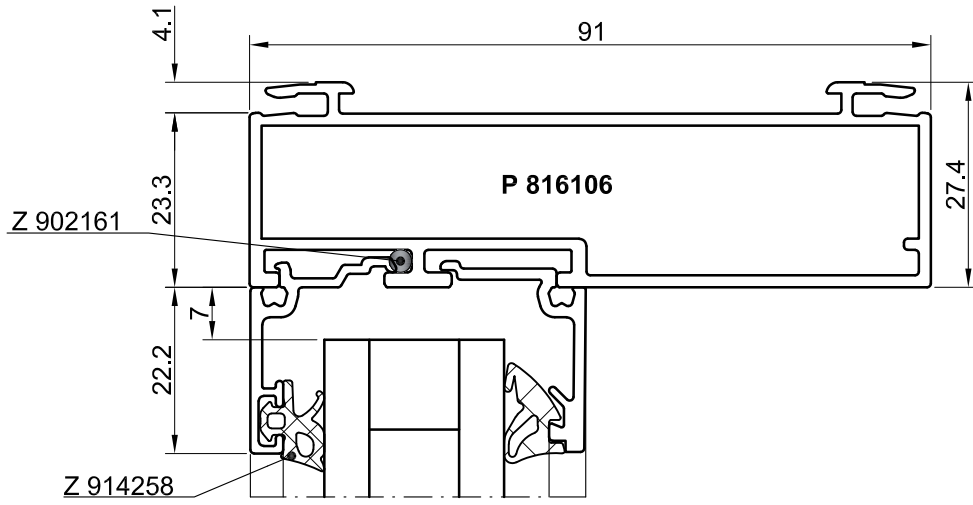
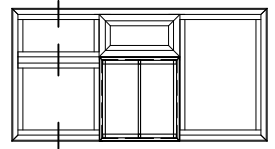

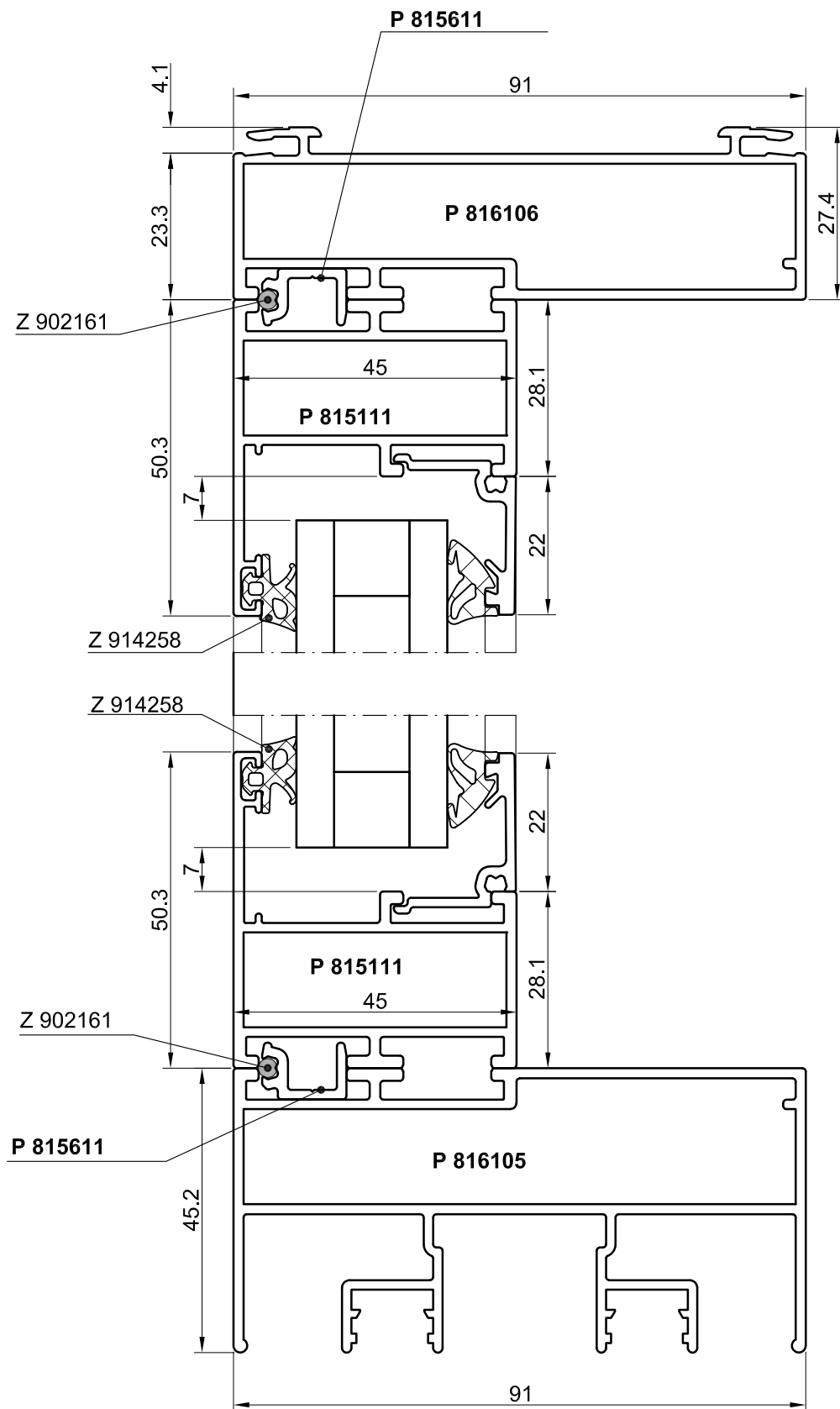
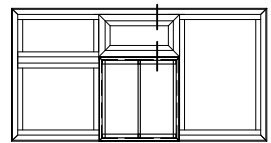

057001700

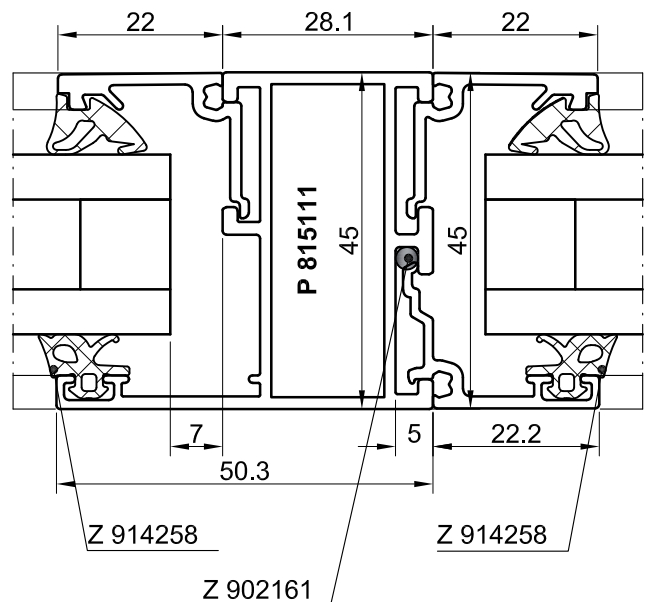
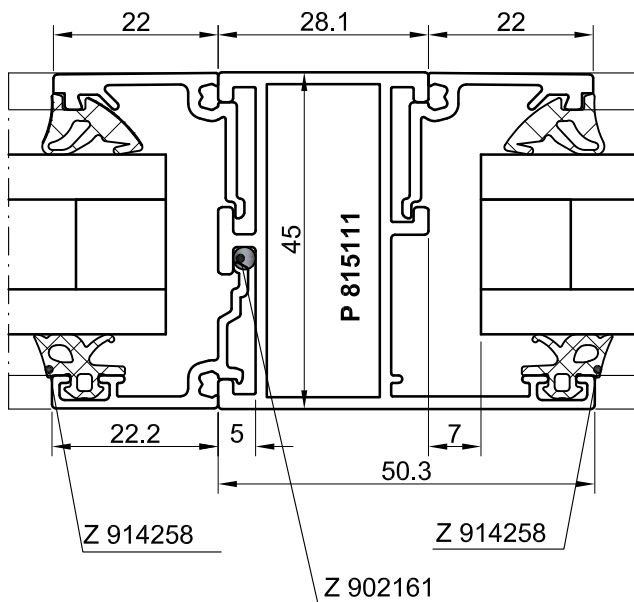
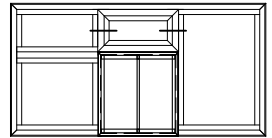

see glazing table

059001900

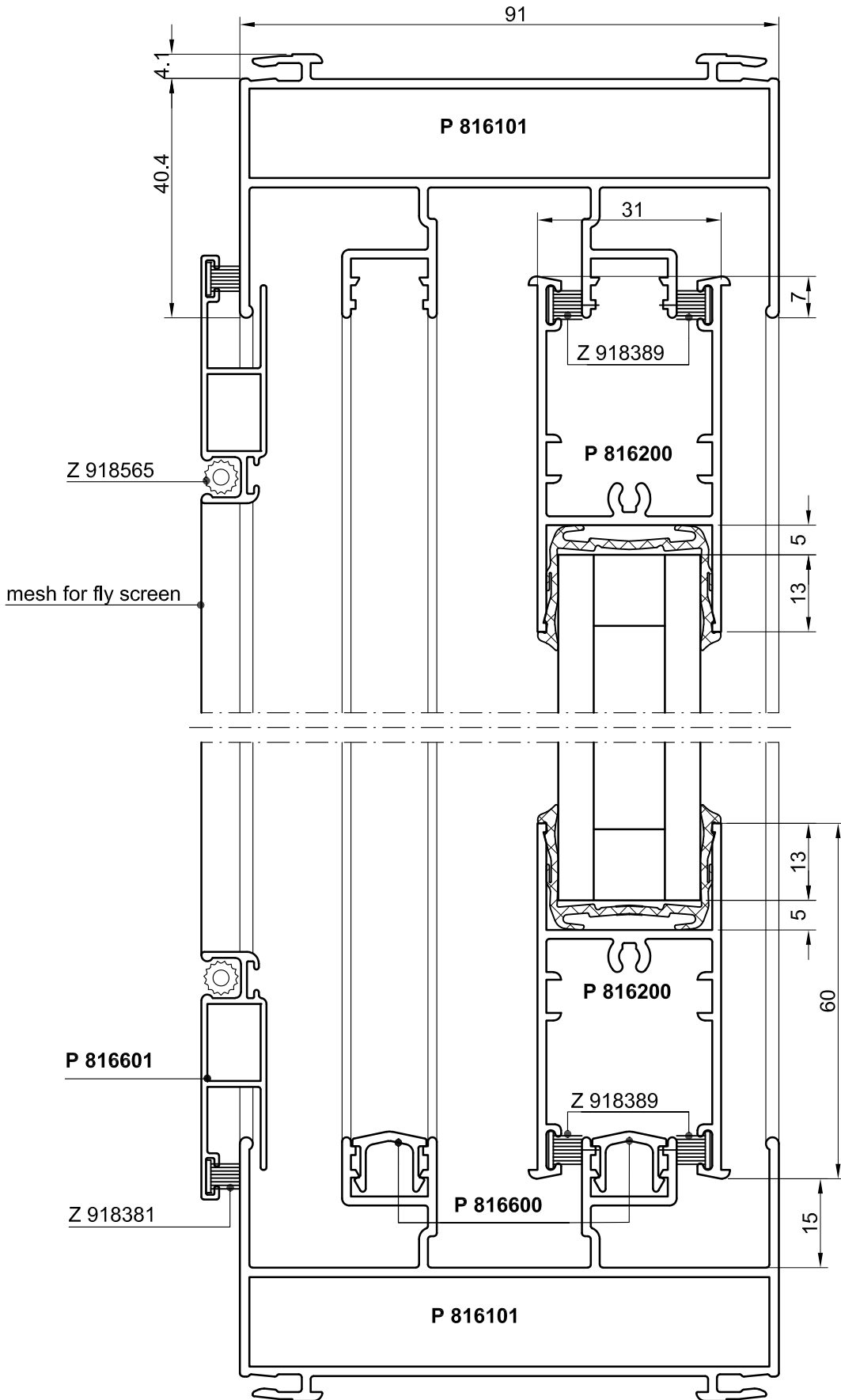
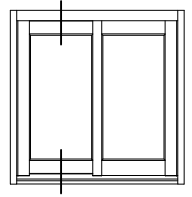

see glazing table

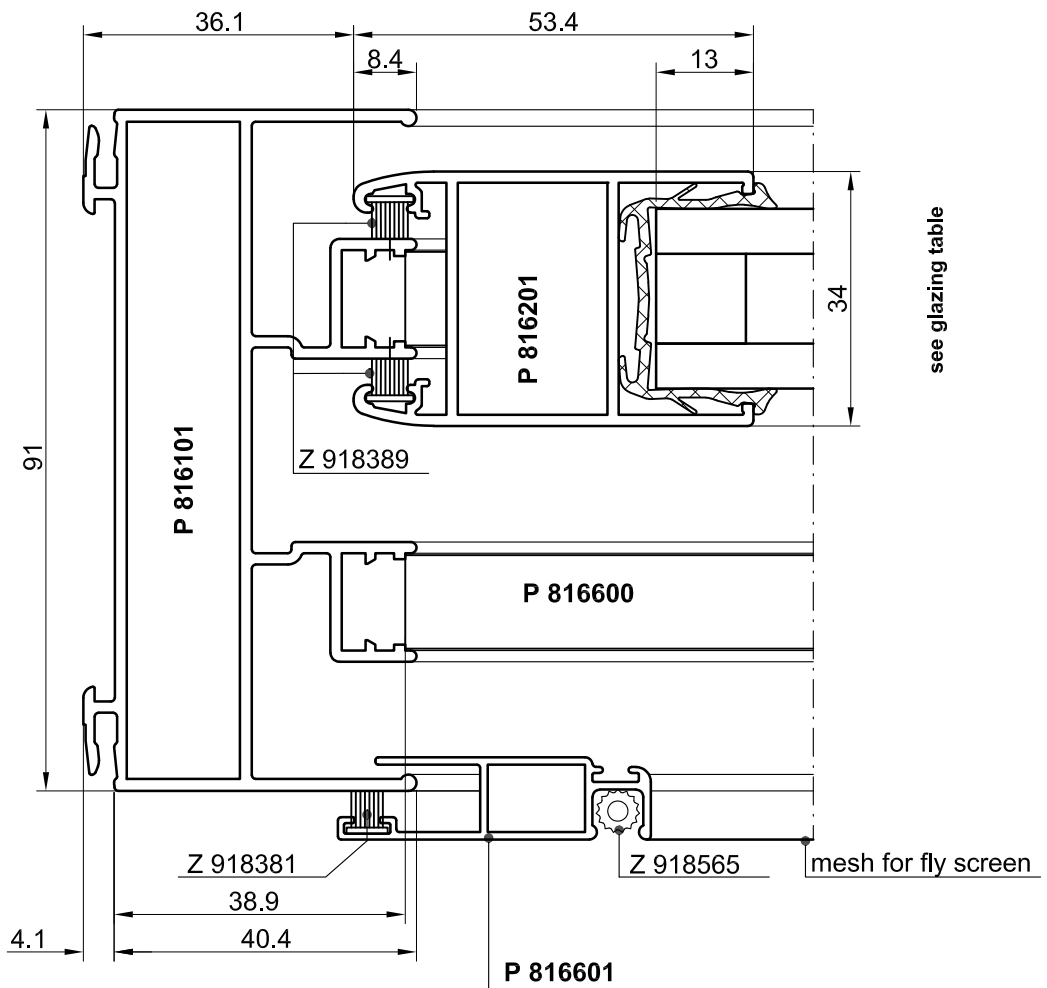
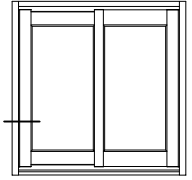

061002100

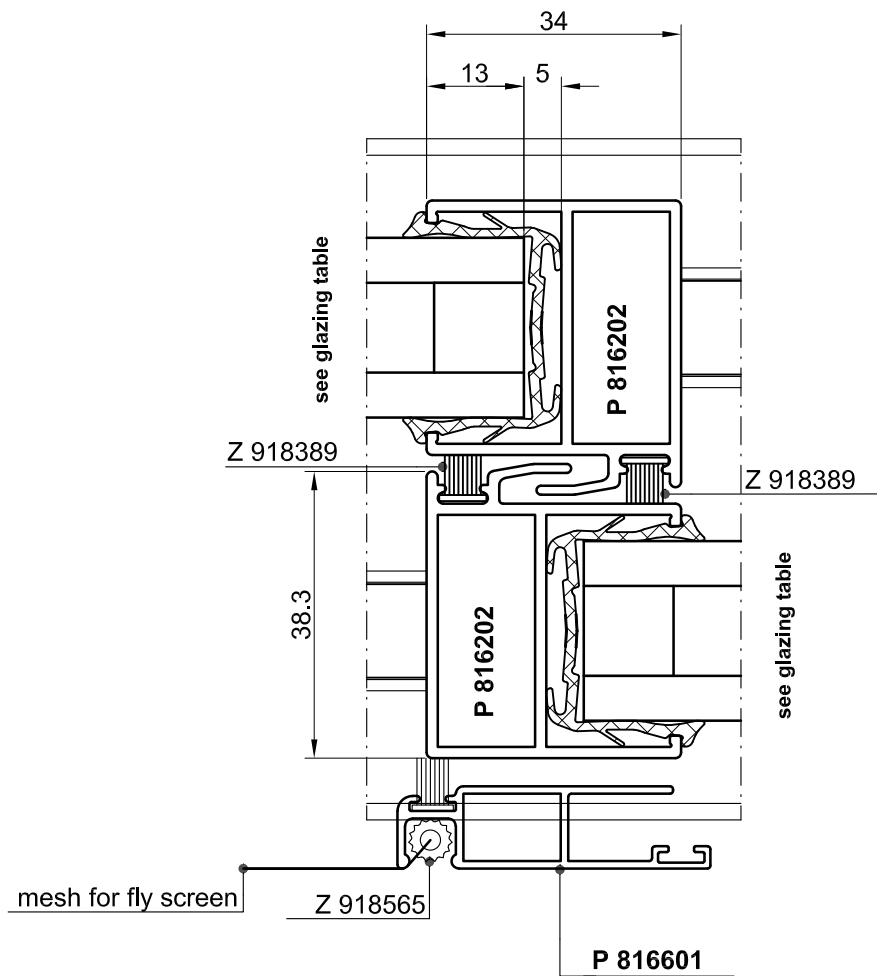
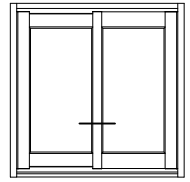

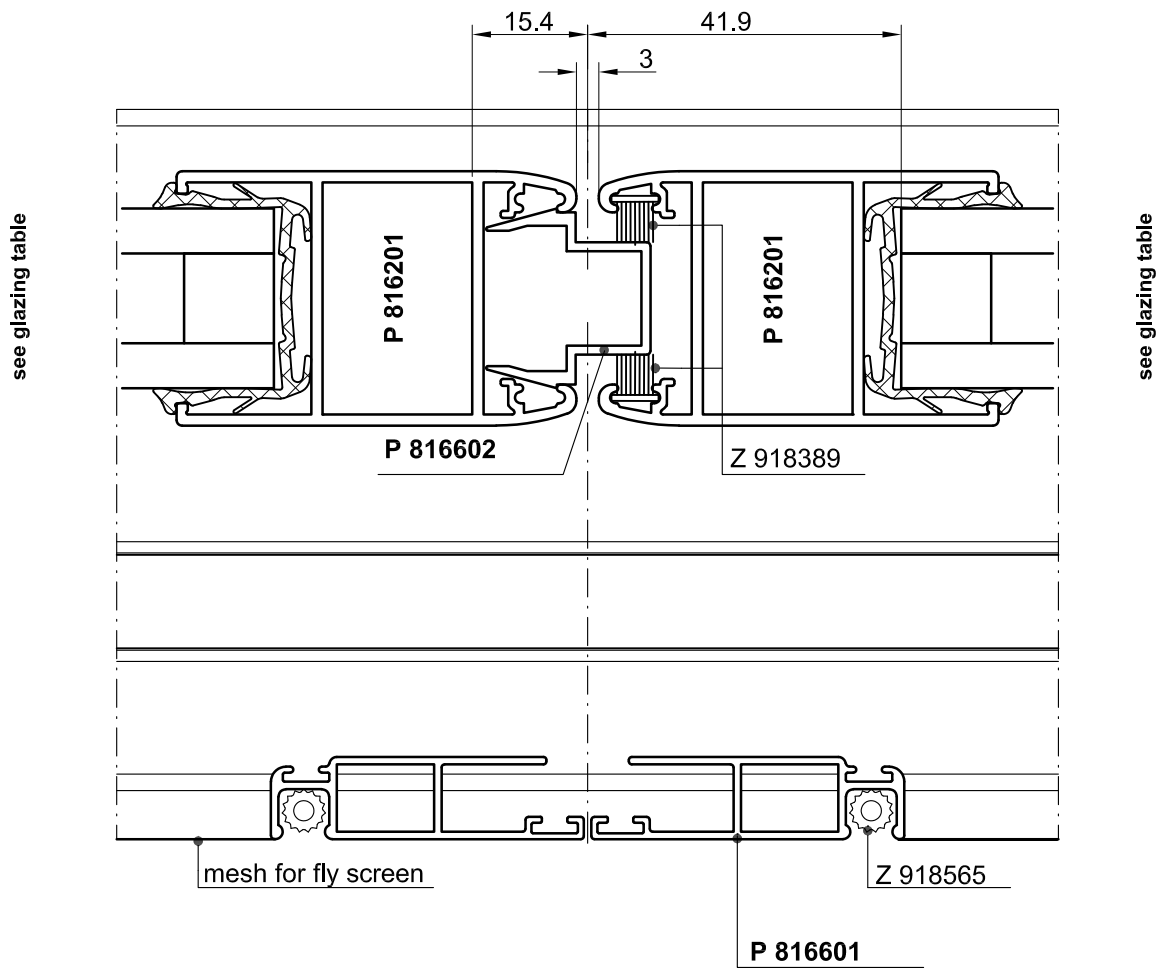
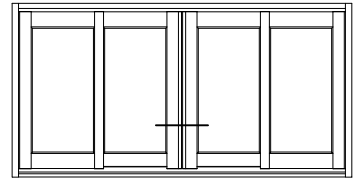

063002300

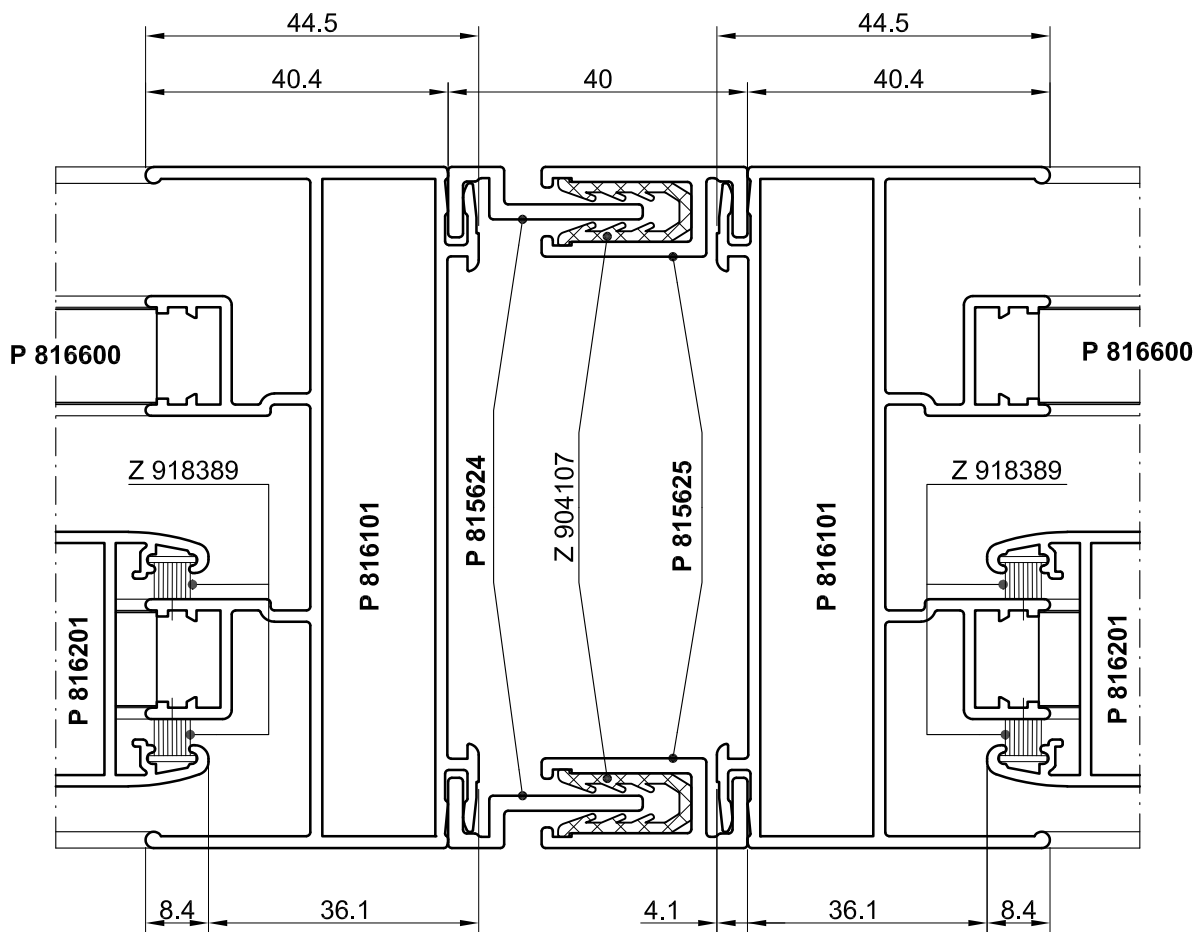
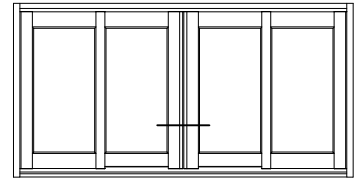

064002400

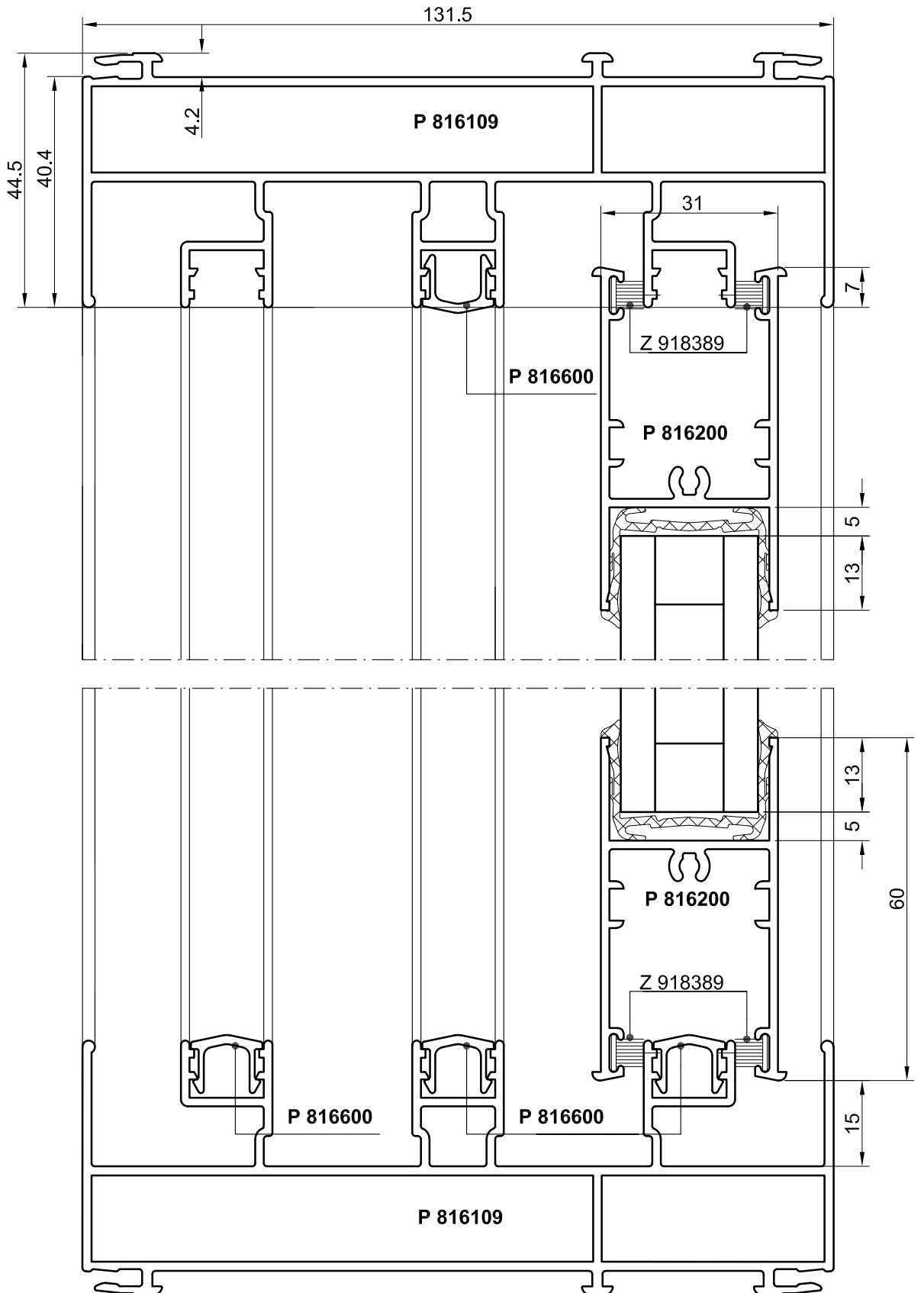
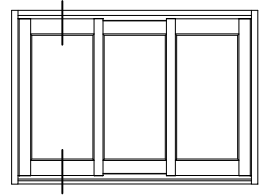

065002400

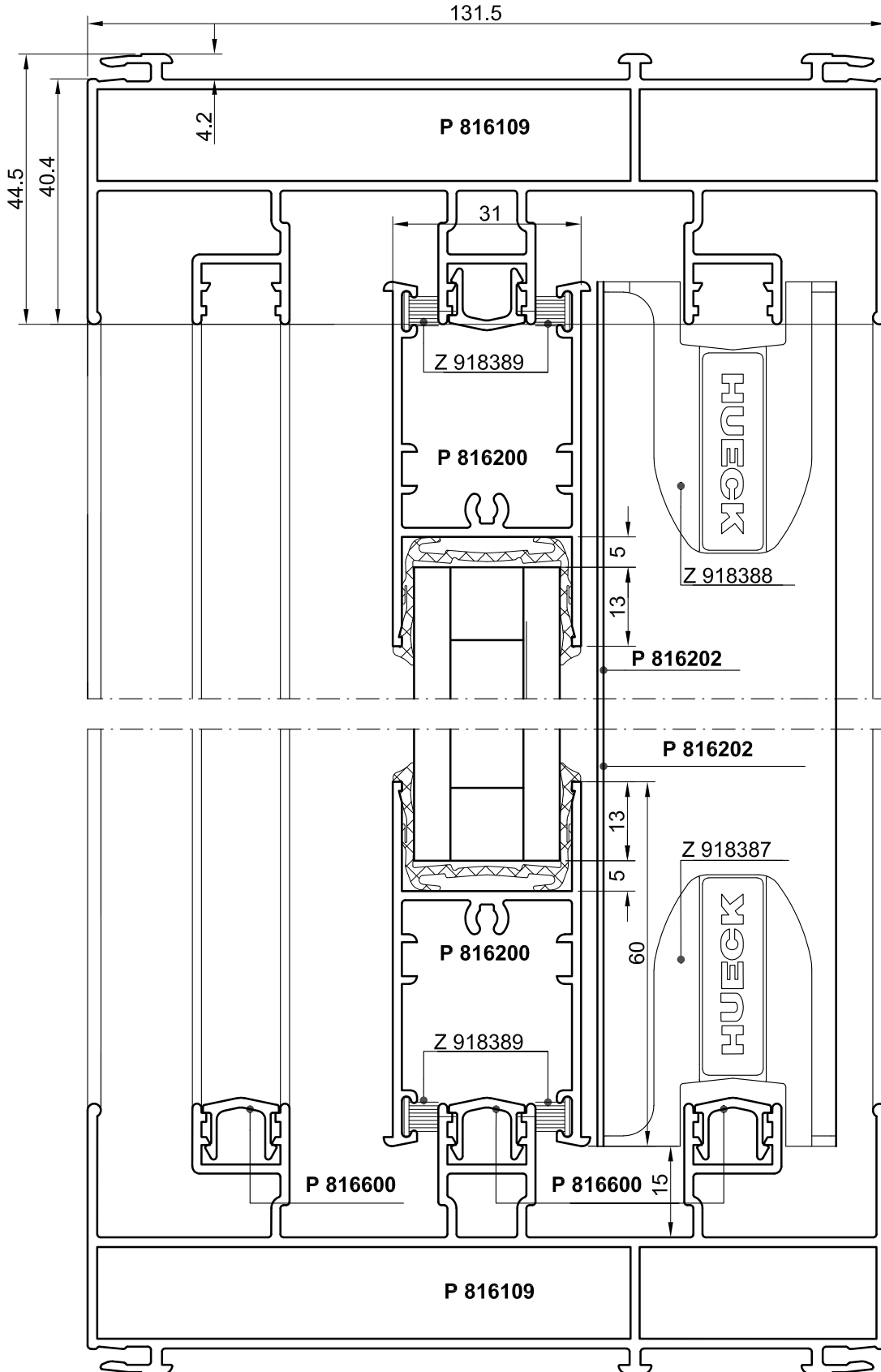
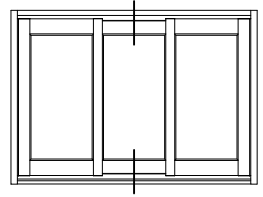

066002400

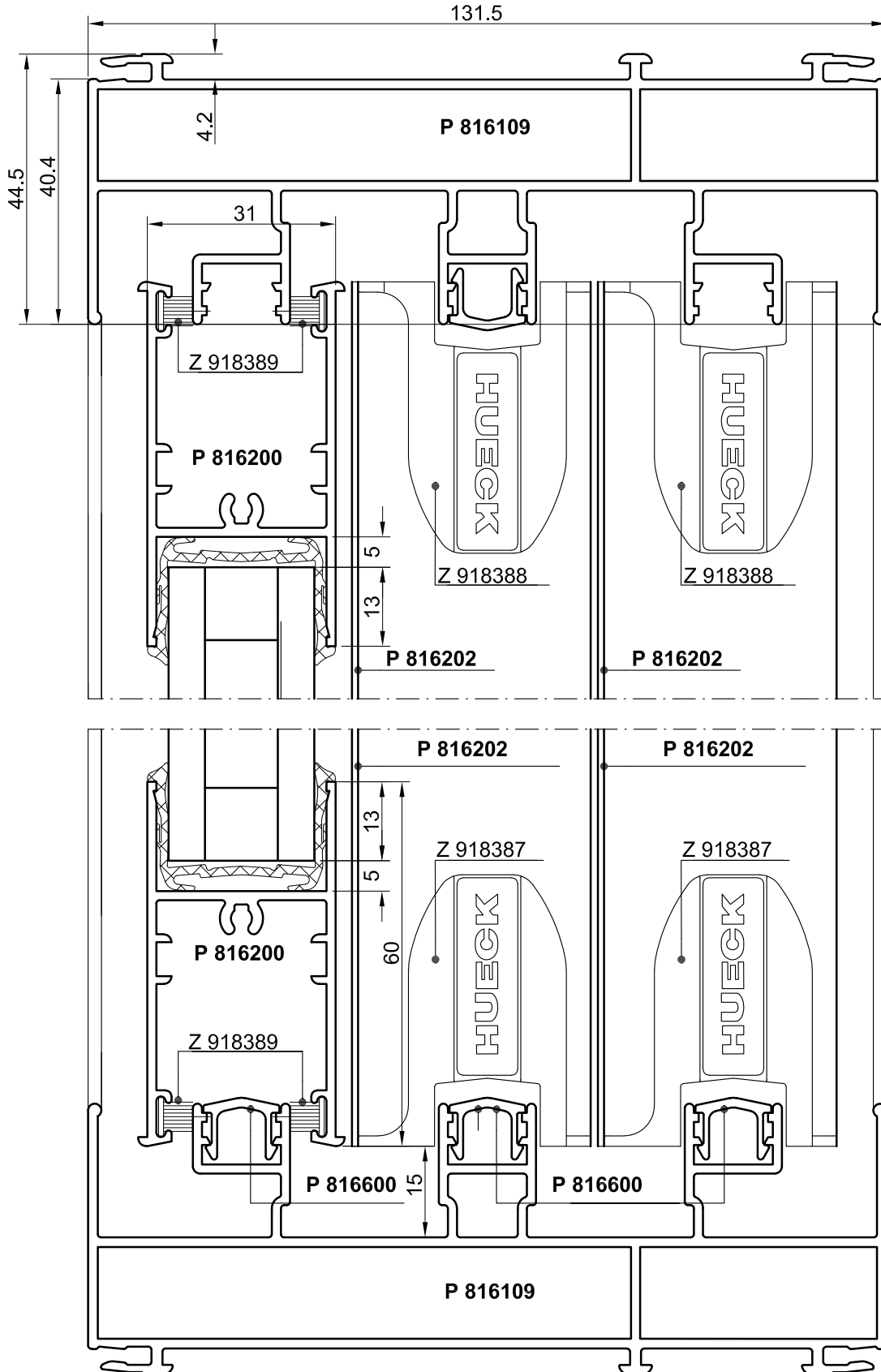
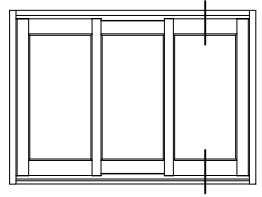

067002400



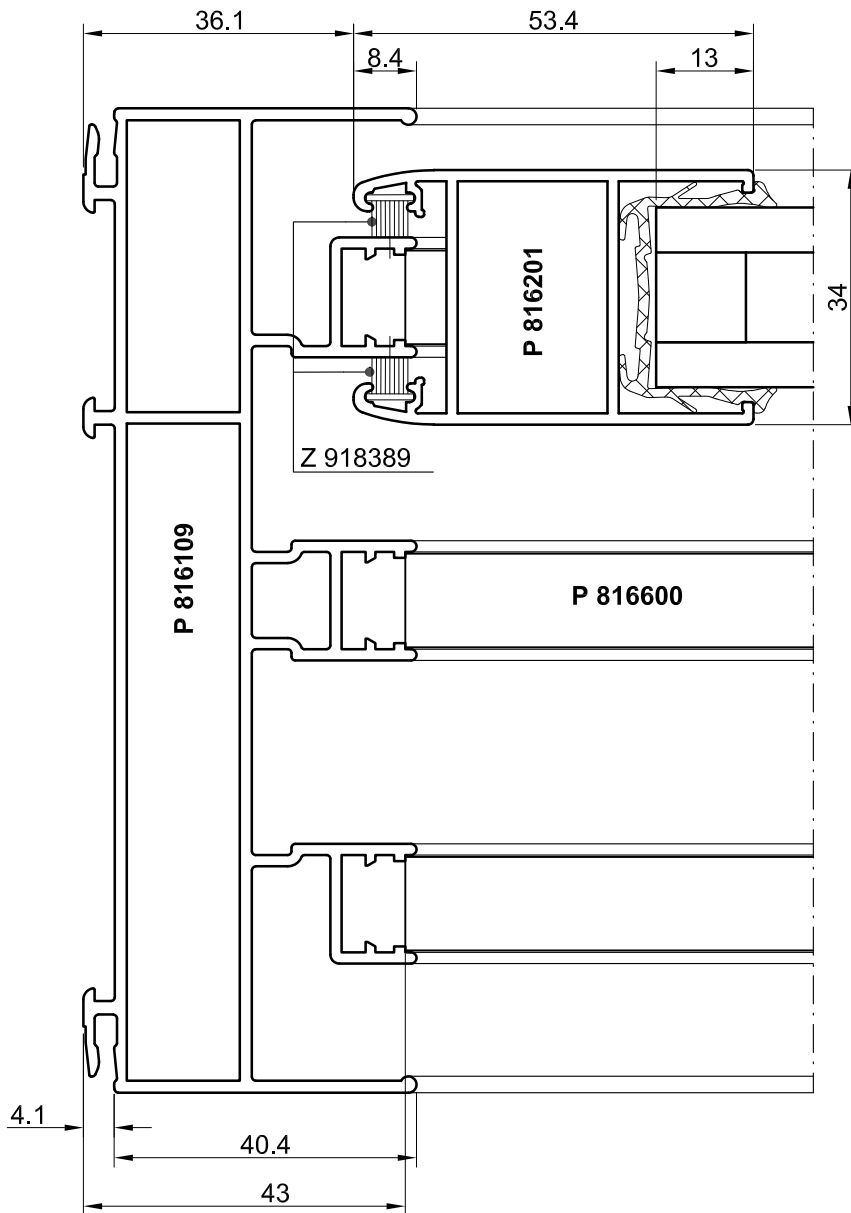
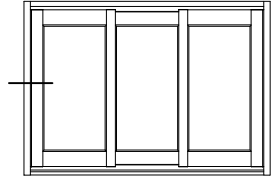

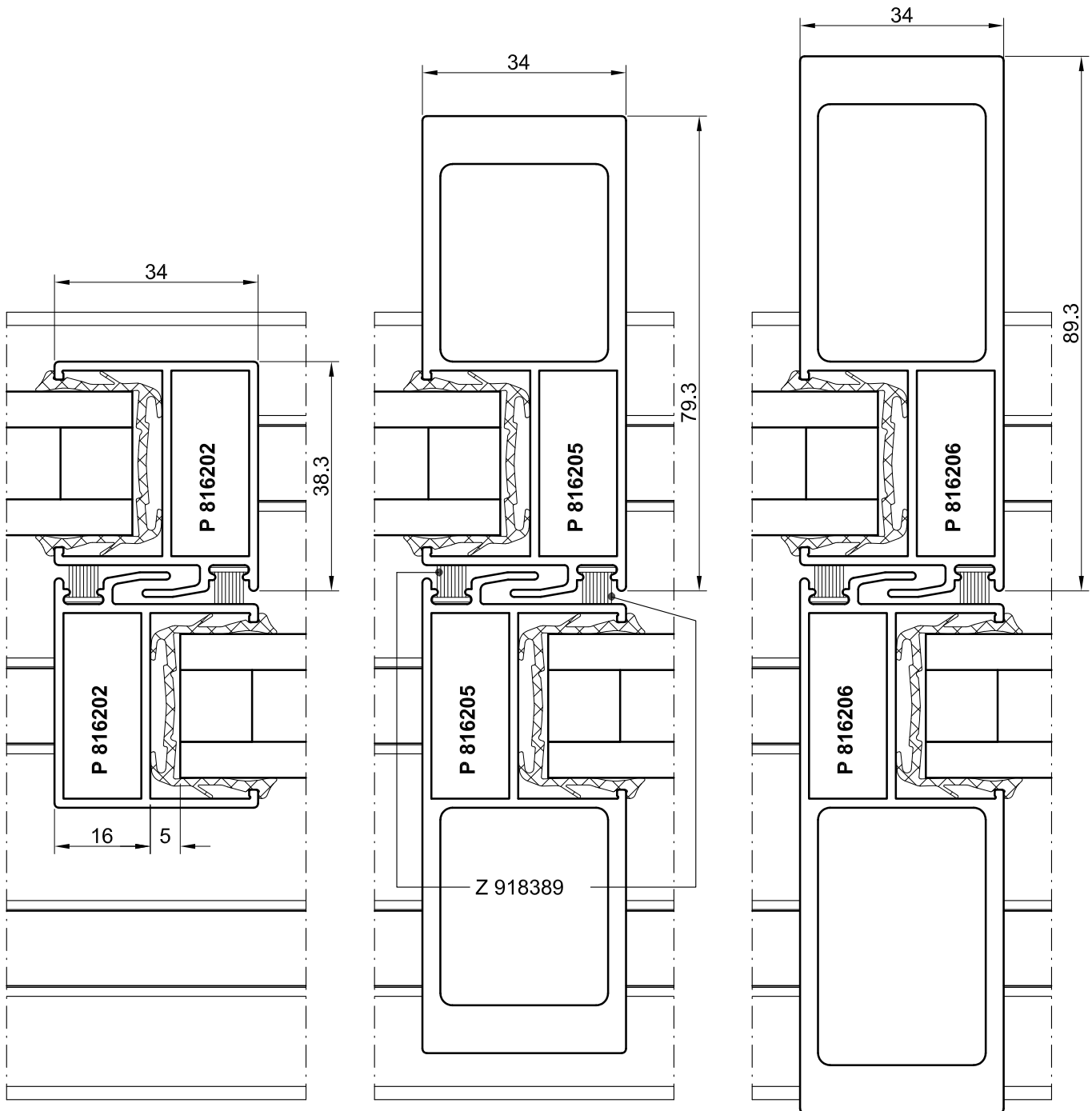
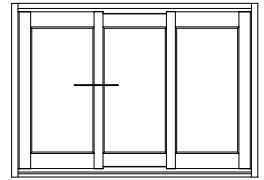

069002400

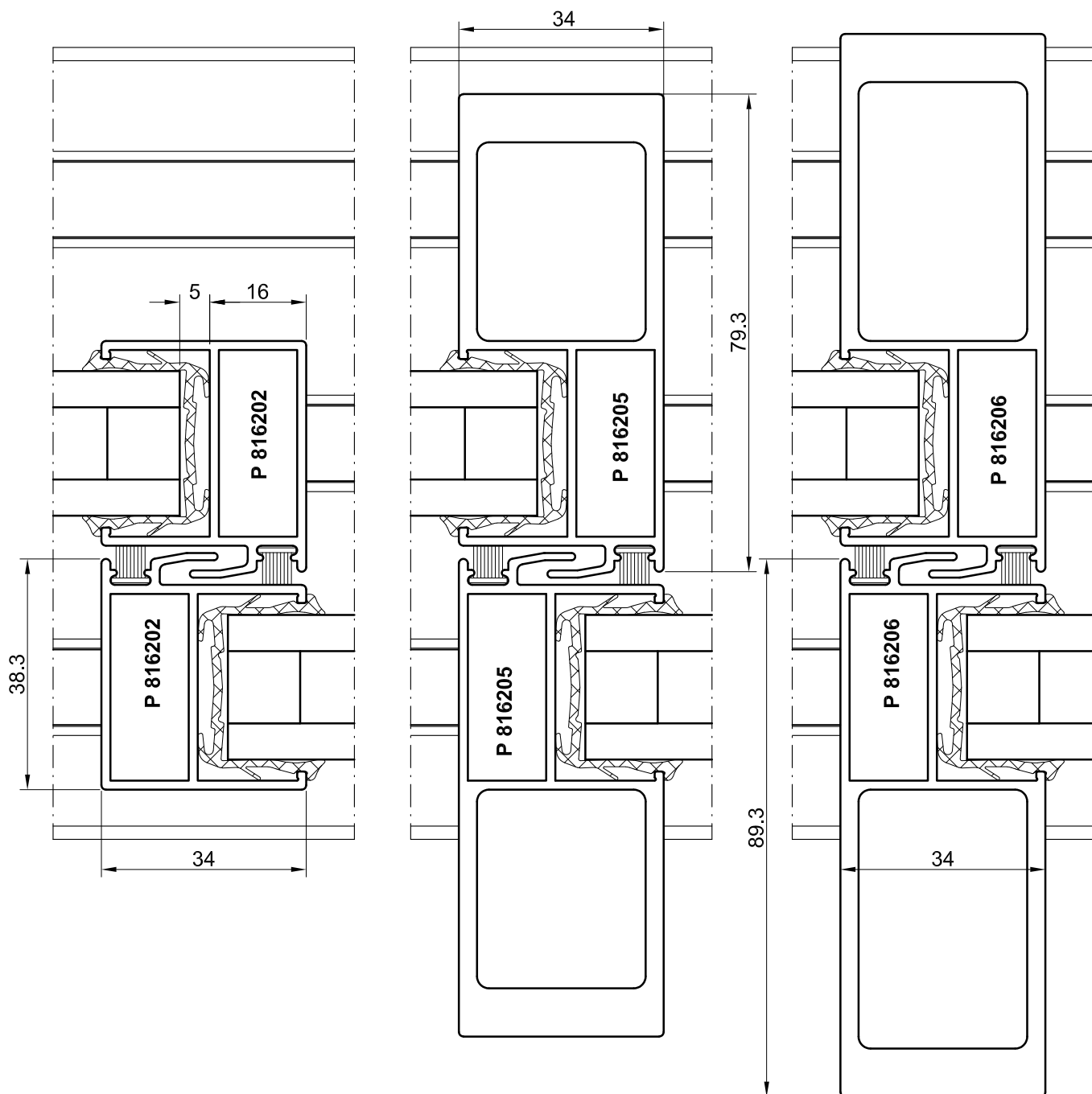
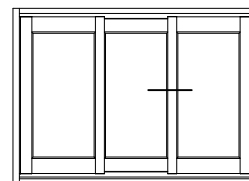

070002400

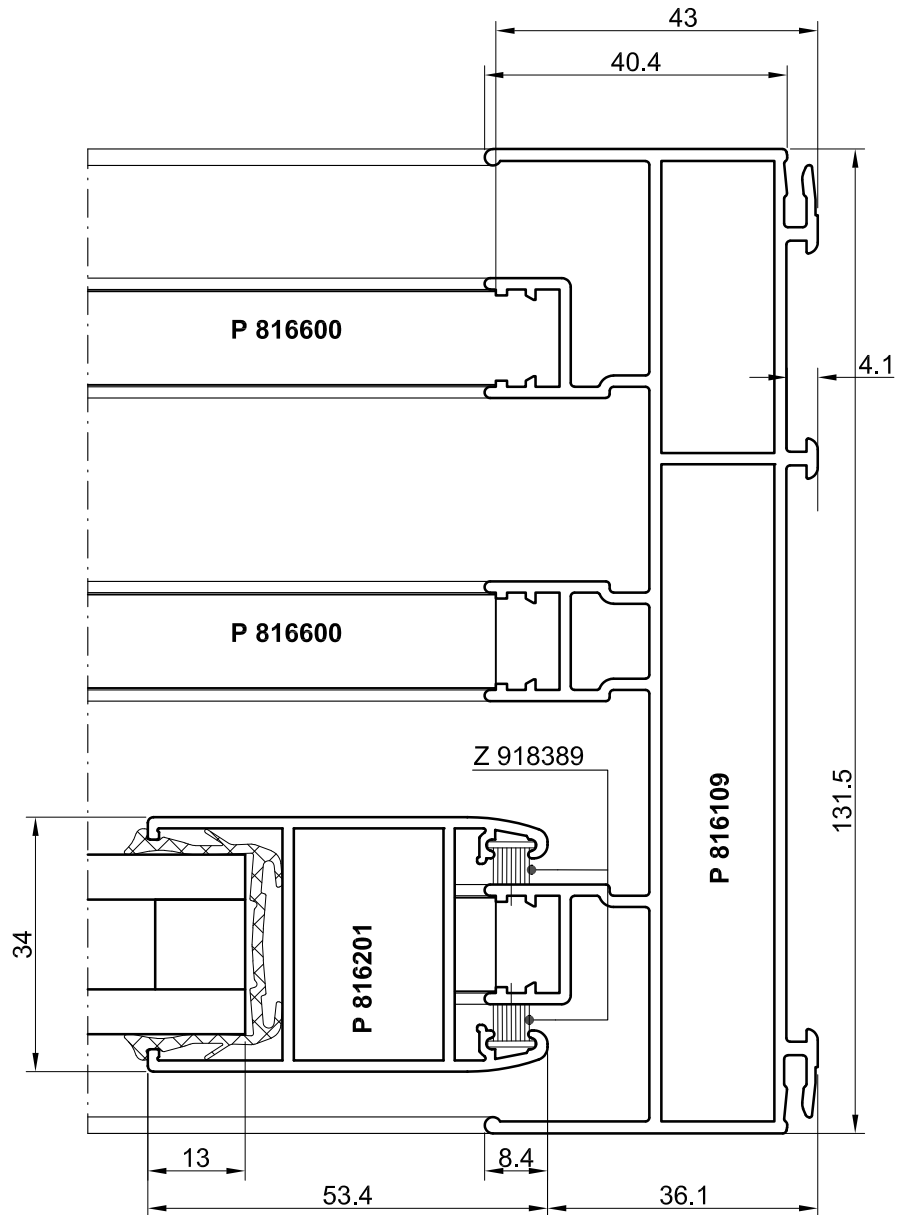
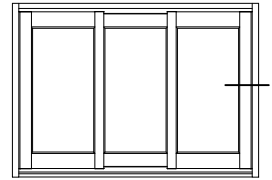

071002400

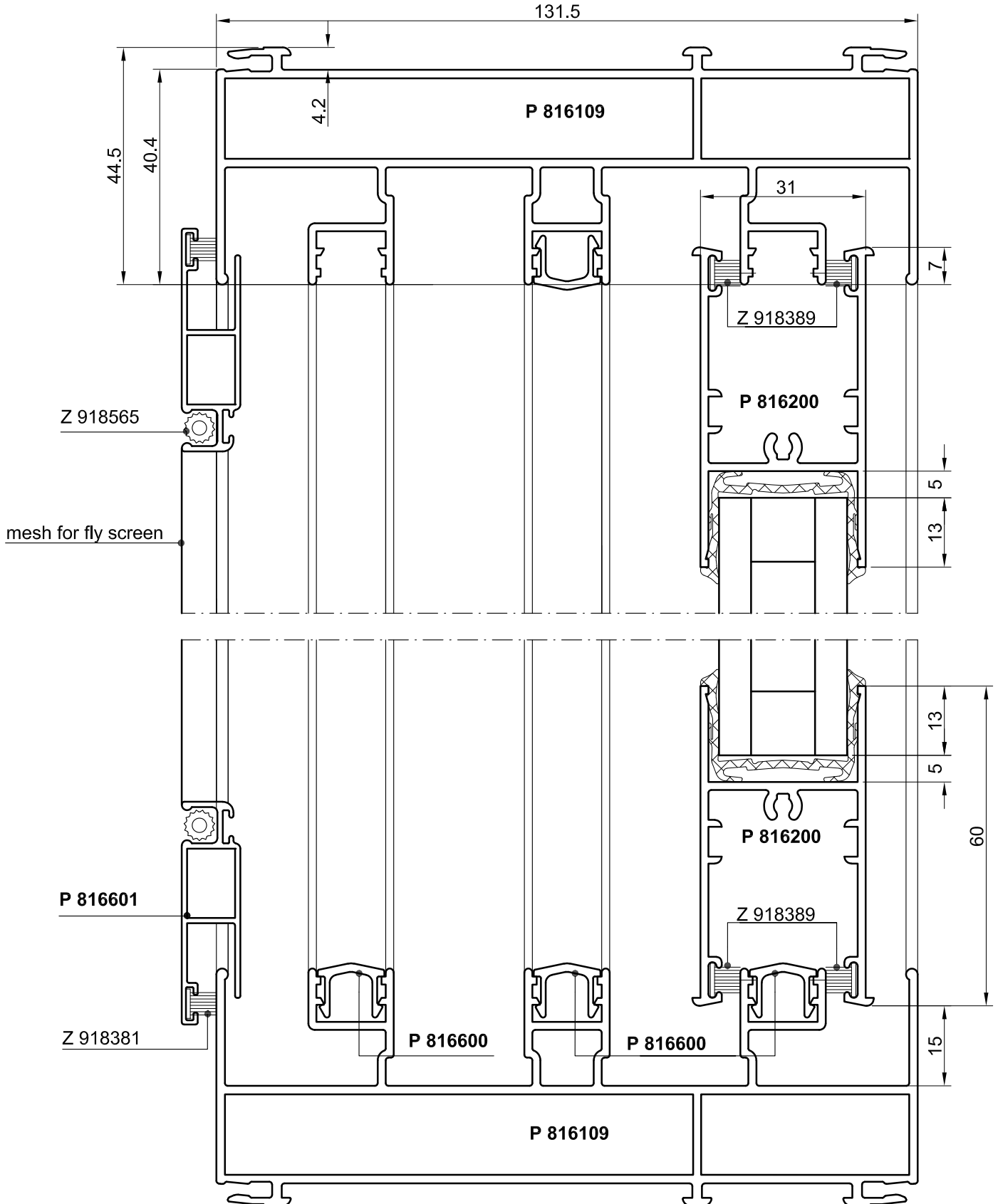
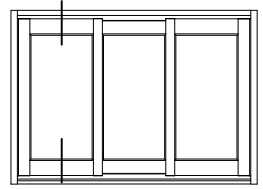

072002400

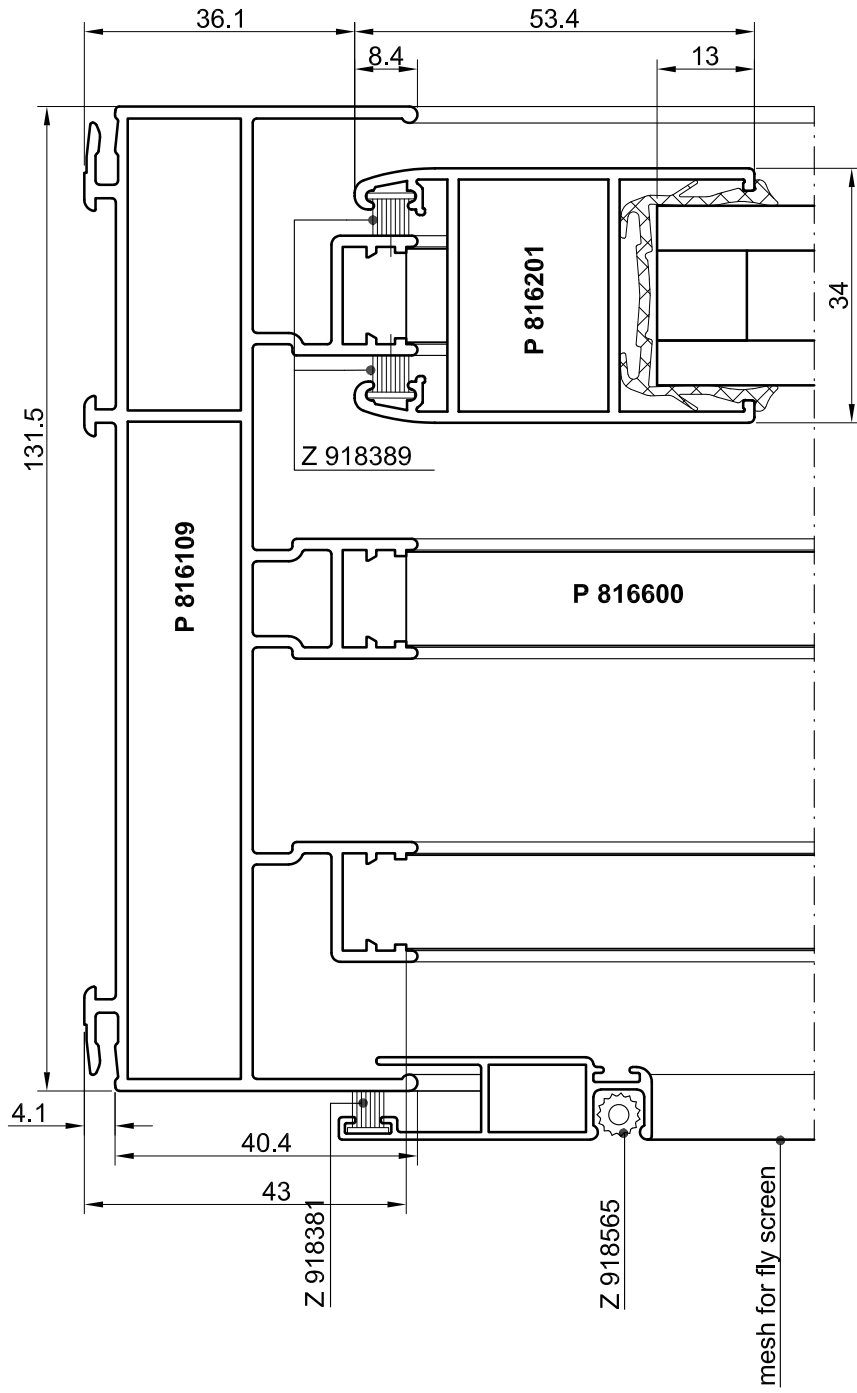
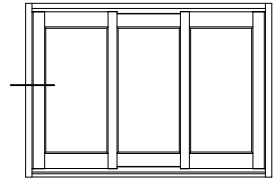

073002400

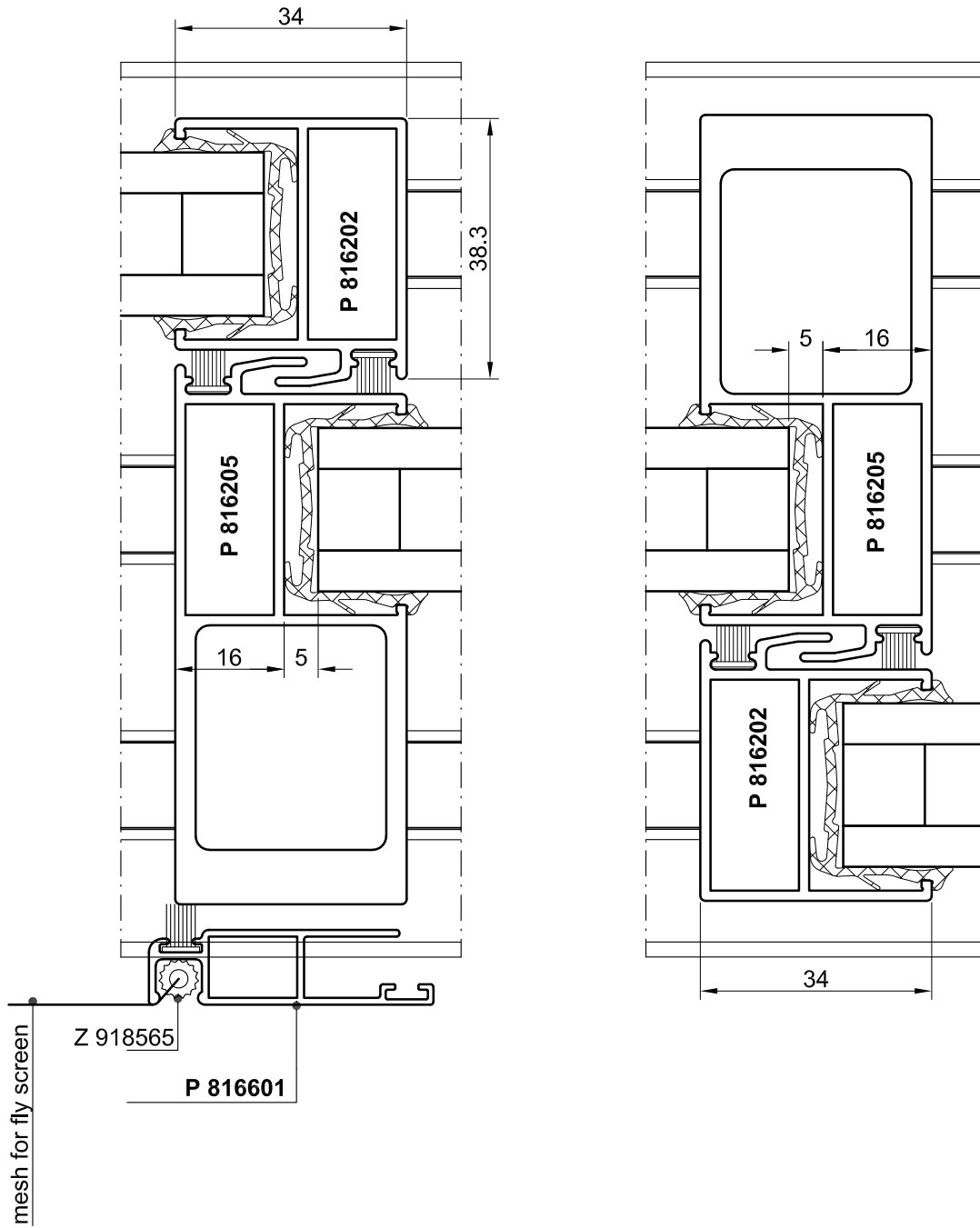
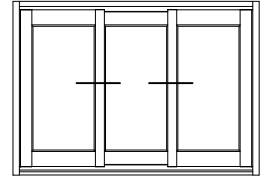

074002400

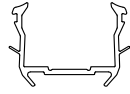

Z 918378 22

Glazing gasket
for glas thickness of 24 mm glas
EPDM, black
Surface: siliconised

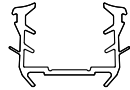

Z 918592 22

Glazing gasket
for glas thickness of 22 mm glas
EPDM, black
Surface: siliconised



Z 918593 22

Glazing gasket
for glas thickness of 20 mm glas
EPDM, black
Surface: siliconised



Z 918594 22

Glazing gasket
for glas thickness of 6 mm glas
EPDM, black
Surface: siliconised



Z 918595 22

Glazing gasket
for glas thickness of 12 mm glas
EPDM, black
Surface: siliconised



Z 918596 22

Glazing gasket
for glas thickness of 10 mm glas
EPDM, black
Surface: siliconised



Z 918597 22

Glazing gasket
for glas thickness of 8 mm glas
EPDM, black
Surface: siliconised

Installation: refer to processing information

081000100



Z 918727 22

Glazing gasket to use with P 816605
for glass thickness of 6 mm
EPDM, black
Surface: siliconised



Z 918728 22

Glazing gasket to use with P 816605
for glass thickness of 8 mm
EPDM, black
Surface: siliconised



Z 918729 22

Glazing gasket to use with P 816605
for glass thickness of 10 mm
EPDM, black
Surface: siliconised



Z 918730 22

Glazing gasket to use with P 816605
for glass thickness of 12 mm
EPDM, black
Surface: siliconised

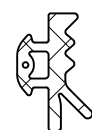

Z 918350 22

Glazing gasket -outside-
for gap dimensions of 2 mm
EPDM, black
Surface: siliconised

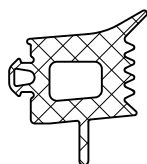

Z 914633 22

Glazing gasket -outside-
for gap dimensions of 13,7 mm
EPDM, black
Surface: siliconised

Installation: refer to processing information

082000200



Z 917981 22

Glazing gasket -internal-
for gap dimensions of 3,5 - 5,5 mm
EPDM, black
Surface: siliconised



Z 914260 22

Glazing gasket -internal-
for gap dimensions of 5,5 - 8 mm
EPDM, black
Surface: siliconised

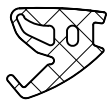

Z 914261 22

Glazing gasket -internal-
for gap dimensions of 6,5 - 9,5 mm
EPDM, black
Surface: siliconised

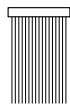

Z 918381

Woven pile weather strip

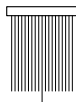

Z 918389

Woven pile weather strip

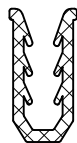

Z 904107 25

Expansion gasket,
EPDM, black
suitable for expansion profiles
for housing a material thickness
of 2 - 3 mm



Z 902161

Gasket cord
rubber foam, dark grey,
Ø 3 mm
for sealing the external
snap-in profiles

Installation: refer to processing information

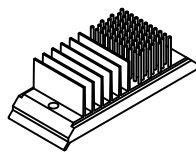

Z 918384

Center seal gasket, shaped piece, EPDM, black, for the sealing in the labyrinth area

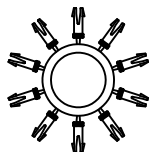

Z 918385

Nail for center seal gasket Z 918384, shaped plastic piece, black, 2 pieces per shaped gasket piece

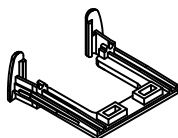

Z 918386

Cover labyrinth, lock side, closed page, shaped plastic piece, black

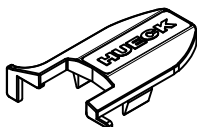

Z 918387

Cover labyrinth area, left shaped plastic piece, black

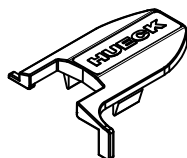

Z 918388

Cover labyrinth area, right shaped plastic piece, black



Z 917253

Drainage, ball valve, shaped plastic piece, black

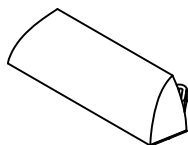

Z 918505

Drainage cap without membrane, shaped plastic piece, black

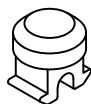

Z 918631

Stop buffer vulcanized

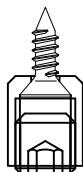

Z 993546

Lift out safety device for fixed sash

Installation: refer to processing information

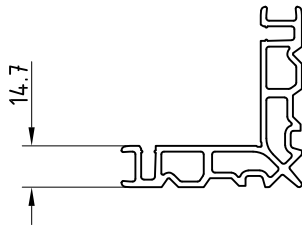

Z 918393

Corner bracket 87,3 mm
(from profil P 599343)

Z 923071

Corner bracket 38,5 mm
(from profil P 599343)

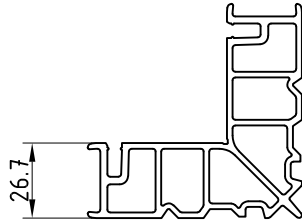

Z 918570

Corner bracket 87,3 mm
(from profil P 599348)

Z 923072

Corner bracket 38,5 mm
(from profil P 599348)



Z 911049

Spring pin for t-bracket and corner
bracket external,
5 mm

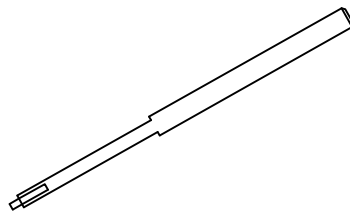

Z 911187

Mandrel to drive in t-bracket for
spring pin, r 5mm

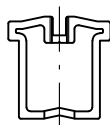

Z 918566

Distance for fixed field for P
816200.
(From profil P 816606)

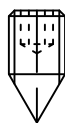

Z 901853

threaded pin,
DIN 914 M5 x 10



Z 917691

punch screw M6
Z 917691

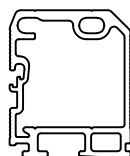

Z 918502

T- bracket 14,7 mm
(from profil P 599362)



Z 914288

silicon gasket strip

Installation: refer to processing information

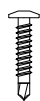

Z 903709

Screw,
for sliding sash
DIN 7504 4,2 x 22



Z 905172

Screw,
DIN 7981 3,9 x 22



Z 902989

Screw,
DIN 7981 4,8 x 38



Z 907539

Screw,
DIN 7981 4.8 x 70

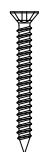

Z 903451

Screw,
DIN 7982 3,9 x 38



Z 900656

Screw,
DIN 7982 3,9 x 19

Installation: refer to processing information

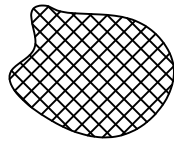

Building site

Mesh,
for fly screen

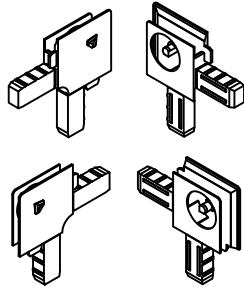

Z 918396

Corner bracket,
for fly screen,
shaped plastic piece, black



Z 918565

PVC gasket for fly screen

Two-component glue



Z 911737

Two-component glue in dual cartridges, 620 ml PU = 6



Z 911738

Statik mixer, required for dual cartridges PU = 50



Z 912717

Sealing material, grey, EPDM suitable, processing temperature 5 - 40 ° Celsius PU = 310 ml in foil cartridge



Z 912718

Sealing material, black, EPDM suitable, processing temperature 5 - 40 ° Celsius PU = 310 ml in foil cartridge



Z 903941

EPDM - glue, black for sealing mitre joints on glazing -gaskets processing temperature 12°-40°C, durability 6 months PU = 200 g tube

PU = packing unit

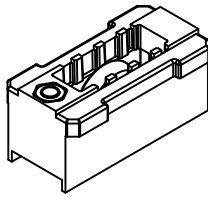

Z 918398

Single roller fixed (sliding)
25 kg / roller

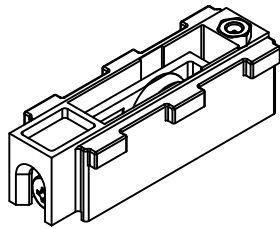

Z 918399

Single roller adjustable (sliding)
20 kg / roller

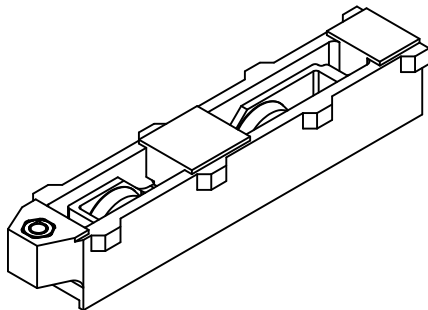

Z 918607

Double roller adjustable (sliding)
50 kg / roller

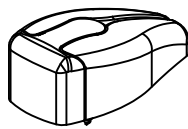

Z 918608

Sliding bumper

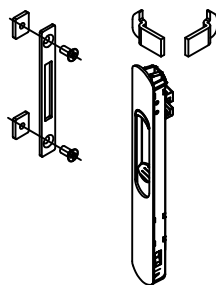

Z 997246 64

Inner click fast mounting
embedded handle -
Semi automatic;
inner kit closing kit

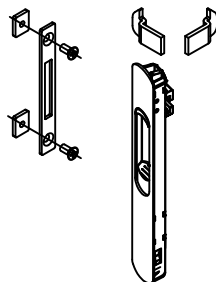

Z 997434 64

Inner click fast mounting
embedded handle -
automatic;
inner kit closing kit

101000100

Installation: refer to processing information

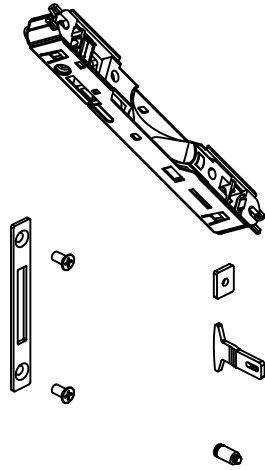

Z 997664

basic lock mechanism set single locking point

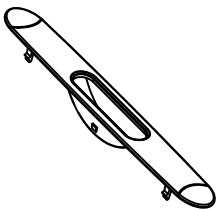

Z 923001

Plate for interiors

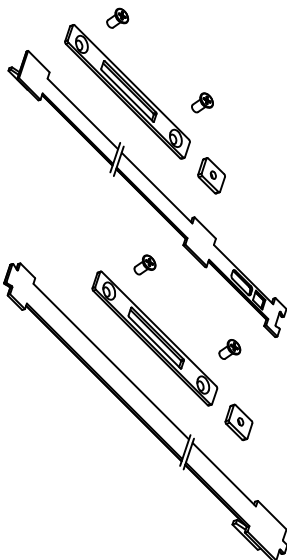

Z 997665

basic lock mechanism set additional locking point

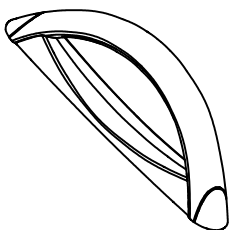

Z 923002

handle outside for multilock

Installation: refer to processing information

102000200

C-C

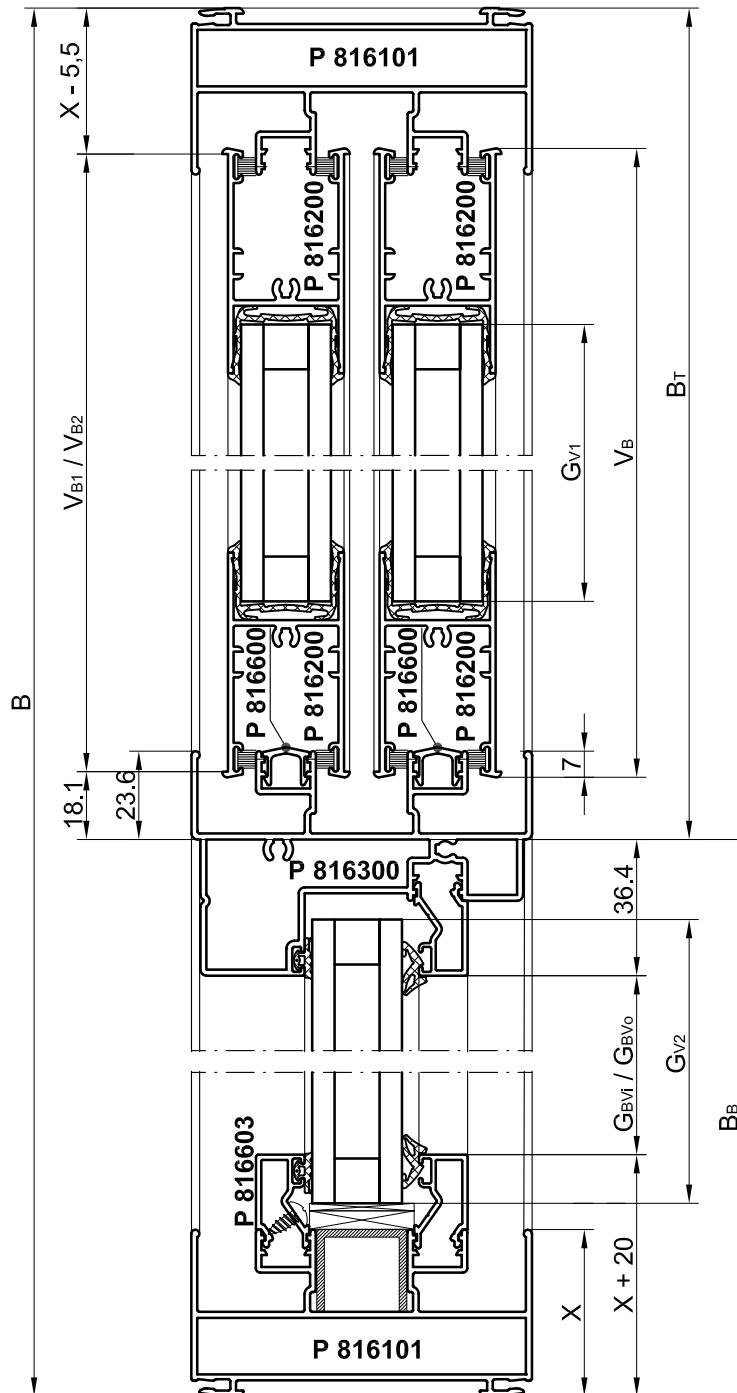

G_{V1}, G_{V2} = see glass dimensions

151000100

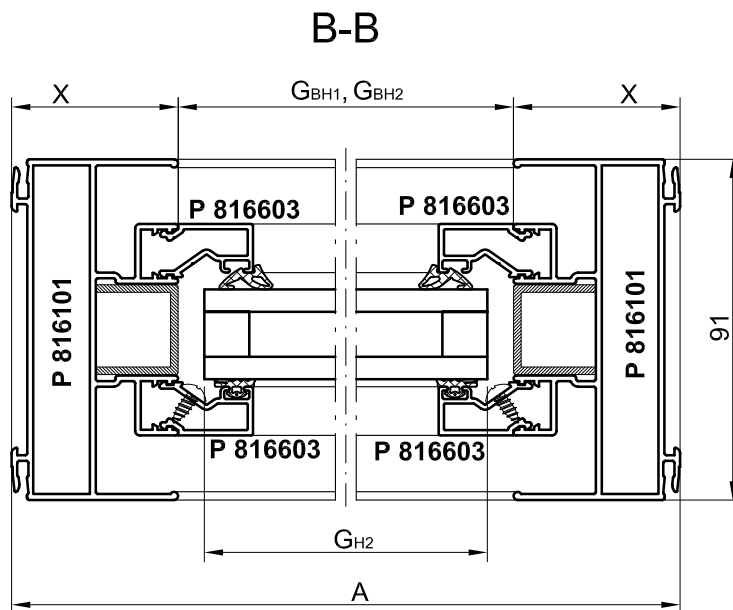
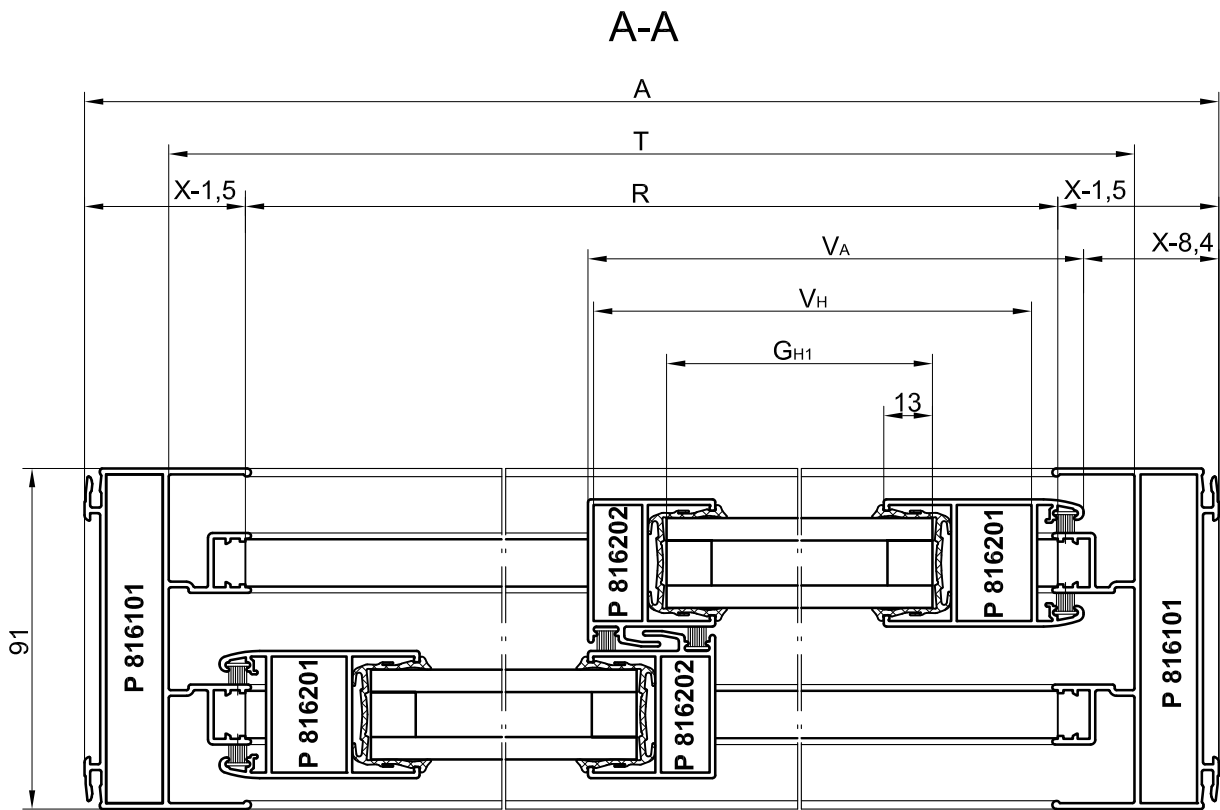

152000200

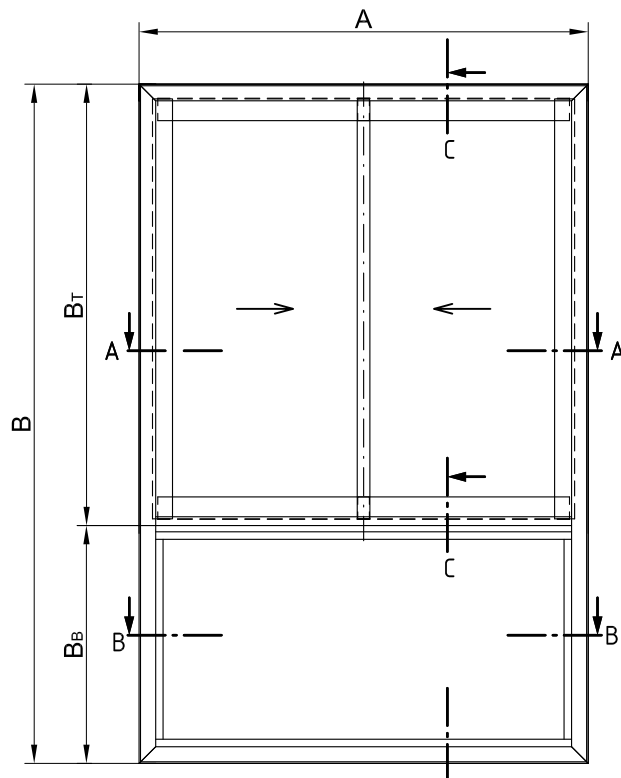

Description	Part no.	X
Frame 44.5	P 816101	44.5
Frame 56.5	P 816104	56.5

Description	Part no.	Calculation	Number	Cut
frame horizontal	P 816101	A = horizontal element dimension	2x	
	P 816104			
frame vertical	P 816101	B = vertical element dimension	2x	
	P 816104	B _B = vertical position of the Transom		
transom	P 816300	T = A - (2 * X) + 44	1x	
vent horizontal		V _A = A / 2 - X + 25,4		
vent vertical		V _B = B _B - 9,6 - X		
vent profile horizontal	P 816200	V _H = A / 2 - X + 10	4x	
vent profile vertical (lock side)	P 816201	V _{B1} = B _B - 12,6 - X	2x	
vent profile vertical (labyrinth side)	P 816202	V _{B2} = B _B - 12,6 - X	2x	
	P 816204			
	P 816205			
	P 816206			
running rail	P 816600	R = A - (2 * X) + 3	2x	
glazing bead horizontal (inside)	P 816603	GB _{Hi} = A - (2 * X)	2x	
	P 816604			
glazing bead horizontal (outside)	P 816603	GB _{Ho} = A - (2 * X)	1x	
glazing bead vertical (inside)	P 816603	GB _{Vi} = B _B - 56,4 - X	2x	
	P 816604			
glazing bead vertical (outside)	P 816603	GB _{Vo} = B _B - 56,4 - X	2x	

153000300

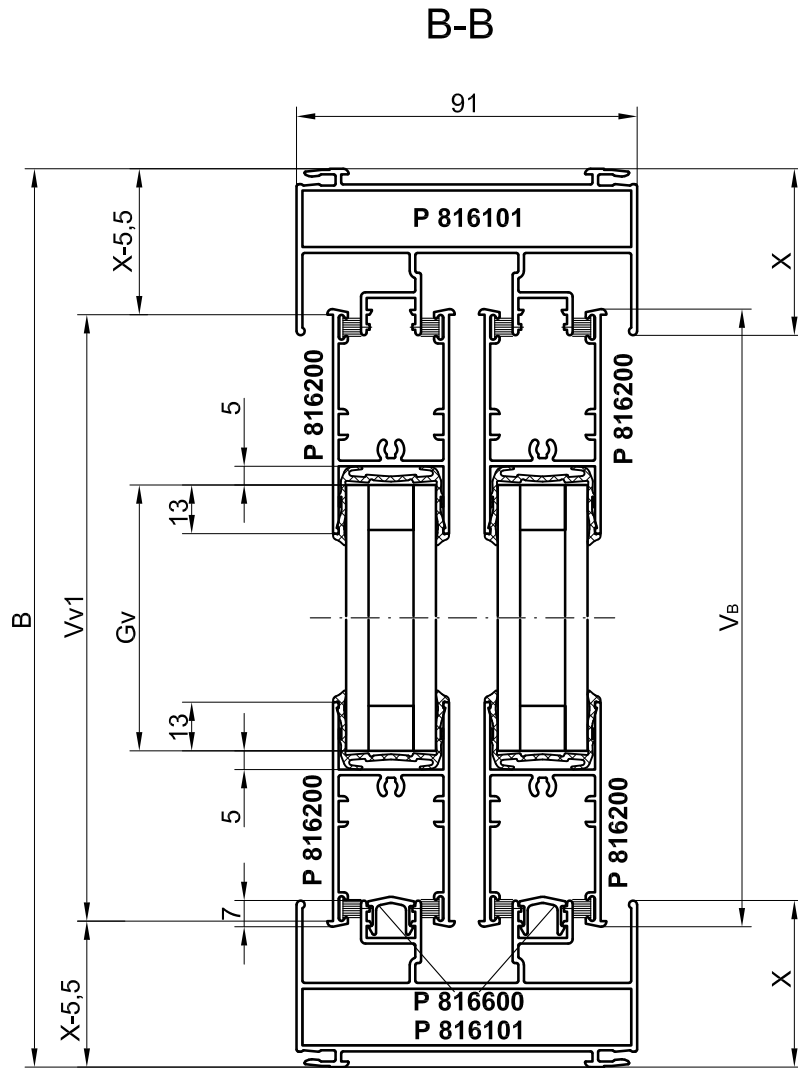

Gv, Gh = see glass dimensions

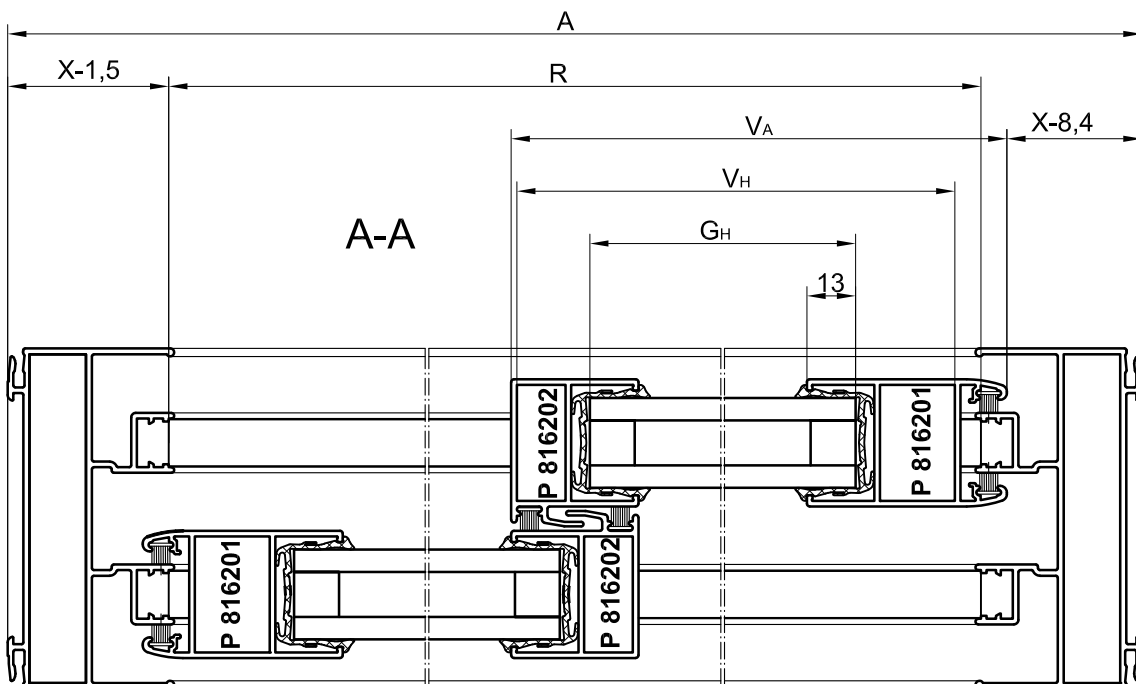

154000400

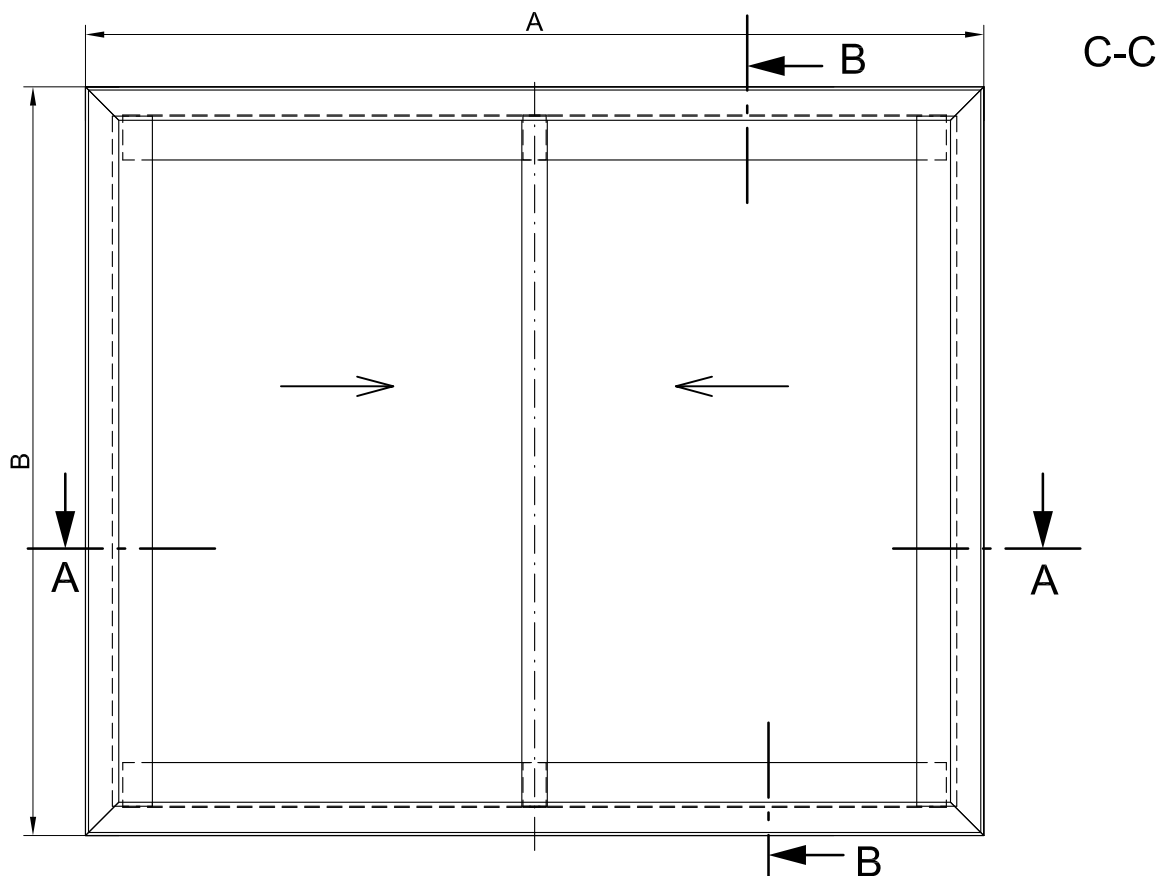

Description	Part no.	X
Frame 44.5	P 816101	44.5
Frame 56.5	P 816104	56.5
Frame 45.2	P 816105	45.2
Frame 57.2	P 816107	57.2

Description	Part no.	Calculation	Number	Cut
frame horizontal	See profile table	A = horizontal element dimension	2x	
frame vertical	See profile table	B = vertical element dimension	2x	
vent horizontal		$V_A = A / 2 - X + 25,4$		
vent vertical		$V_B = B - (2 * X) + 14$		
vent profile horizontal	P 816200	$V_H = A / 2 - X + 10$	4x	
vent profile vertical (lock side)	P 816201	$V_{V1} = B - (2 * X) + 11$	2x	
vent profile vertical (labyrinth side)	P 816202	$V_{V2} = B - (2 * X) + 11$	2x	
	P 816204			
	P 816205			
	P 816206			
running rail	P 816600	$R = A - (2 * X) + 3$	2x	

156006500

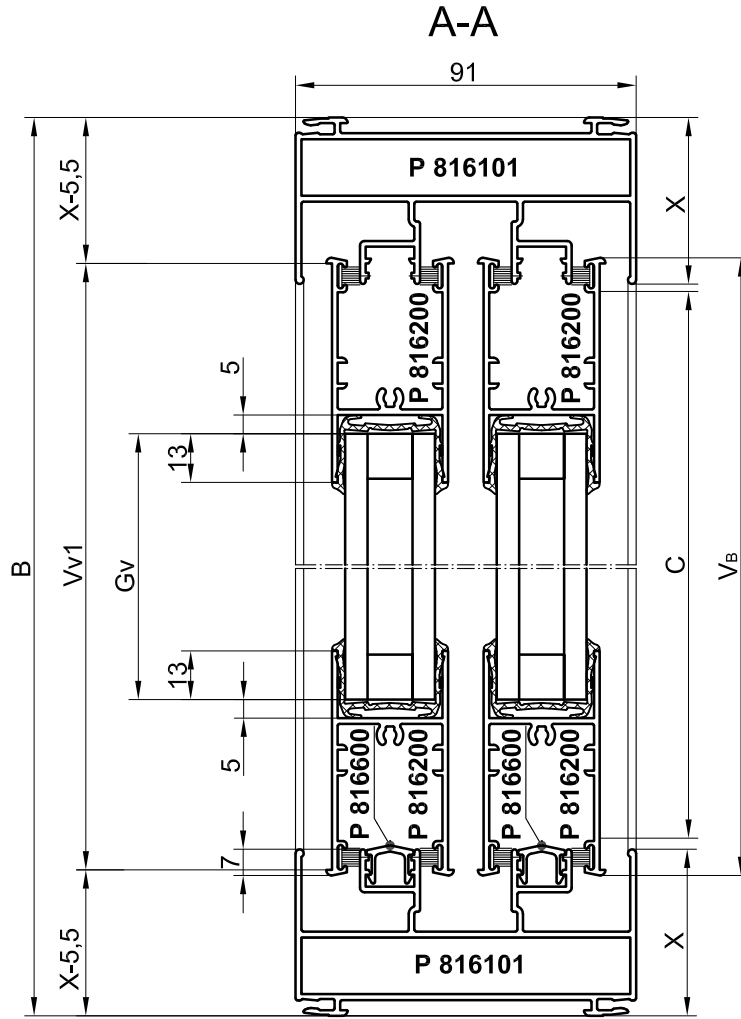

Gv = see glass dimensions

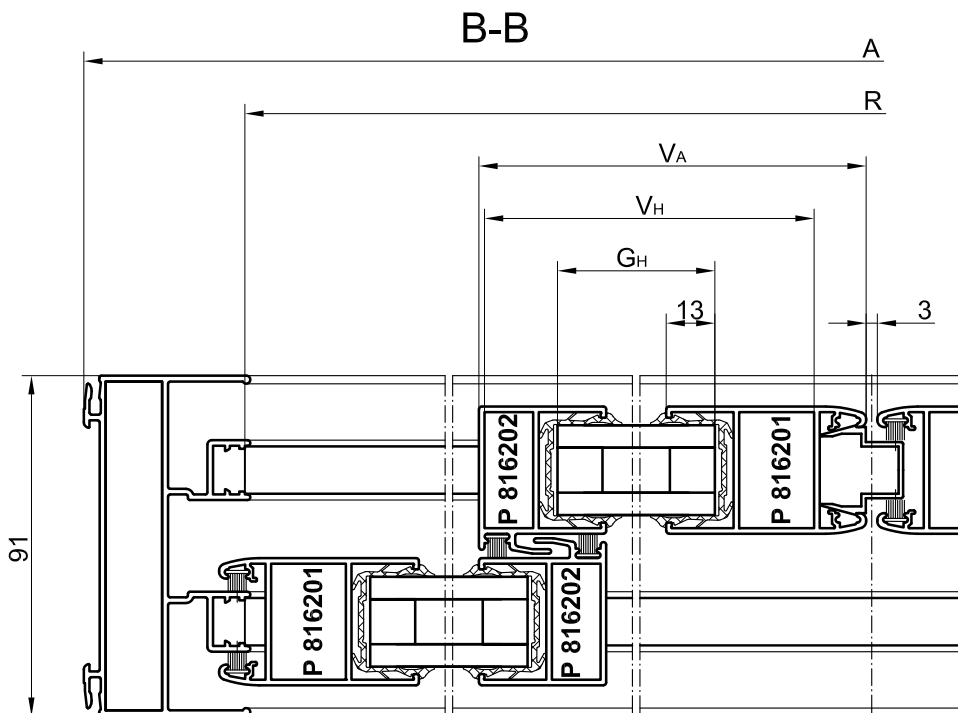

GH = see glass dimensions

156000600

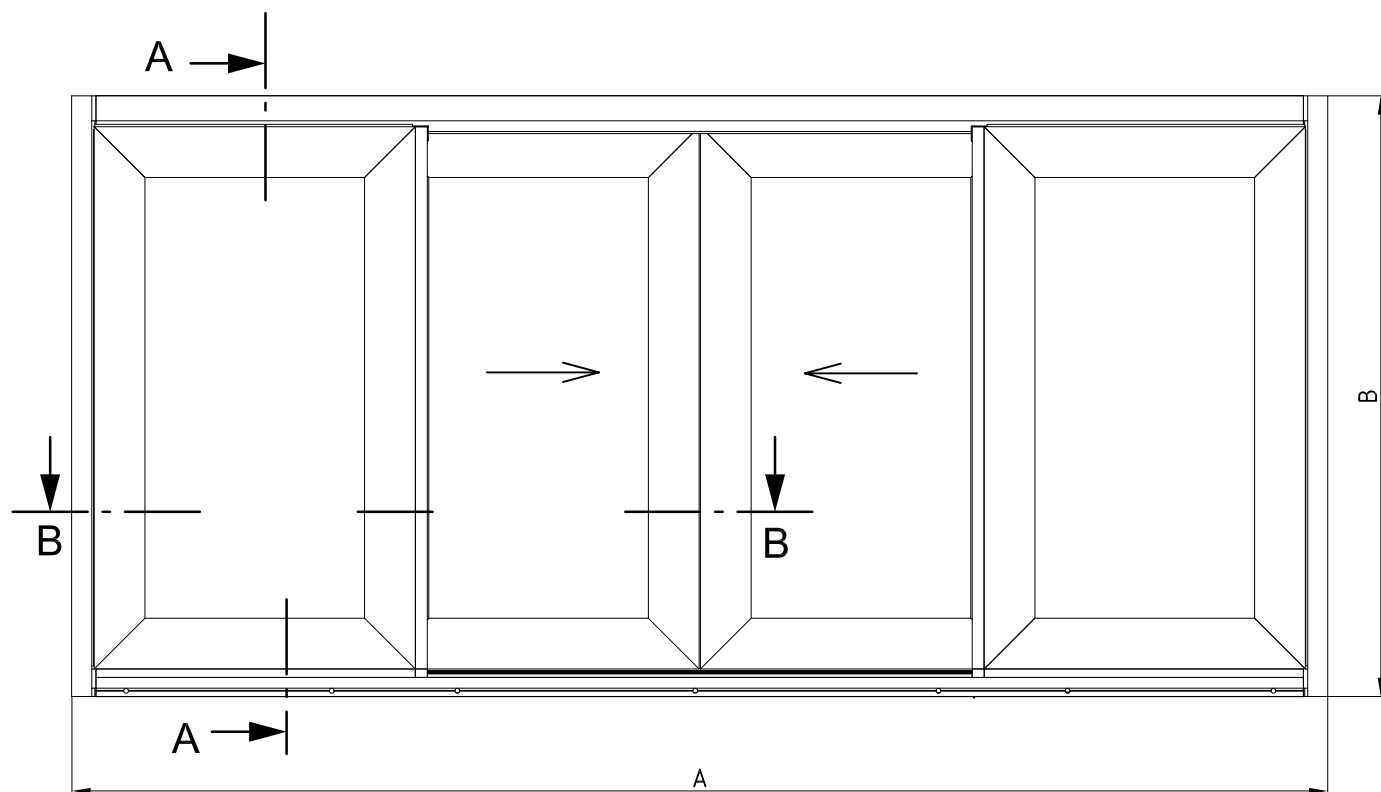

Description	Part no.	X
Frame 44.5	P 816101	44.5
Frame 56.5	P 816104	56.5
Frame 45.2	P 816105	45.2
Frame 57.2	P 816107	57.2

Description	Part no.	Calculation	Number	Cut
frame horizontal	P 816101	A = horizontal element dimension	2x	
	P 816104			
frame vertical	P 816101	B = vertical element dimension	2x	
	P 816104			
vent horizontal		$V_A = (A / 2 - X + 6,9) / 2 + 17$		
vent vertical		$V_B = B - (2 * X) + 14$		
vent profile horizontal	P 816200	$V_H = (A / 2 - X + 6,9) / 2 + 1,6$	8x	
vent profile vertical (lock side)	P 816201	$V_{V1} = B - (2 * X) + 11$	4x	
vent profile vertical (labyrinth side)	P 816202	$V_{V2} = B - (2 * X) + 11$	4x	
	P 816204			
	P 816205			
	P 816206			
extra profile scheme C	P 816602	$C = V_B - 19$	1x	
running rail	P 816600	$R = A - (2 * X) + 3$	2x	

157000700

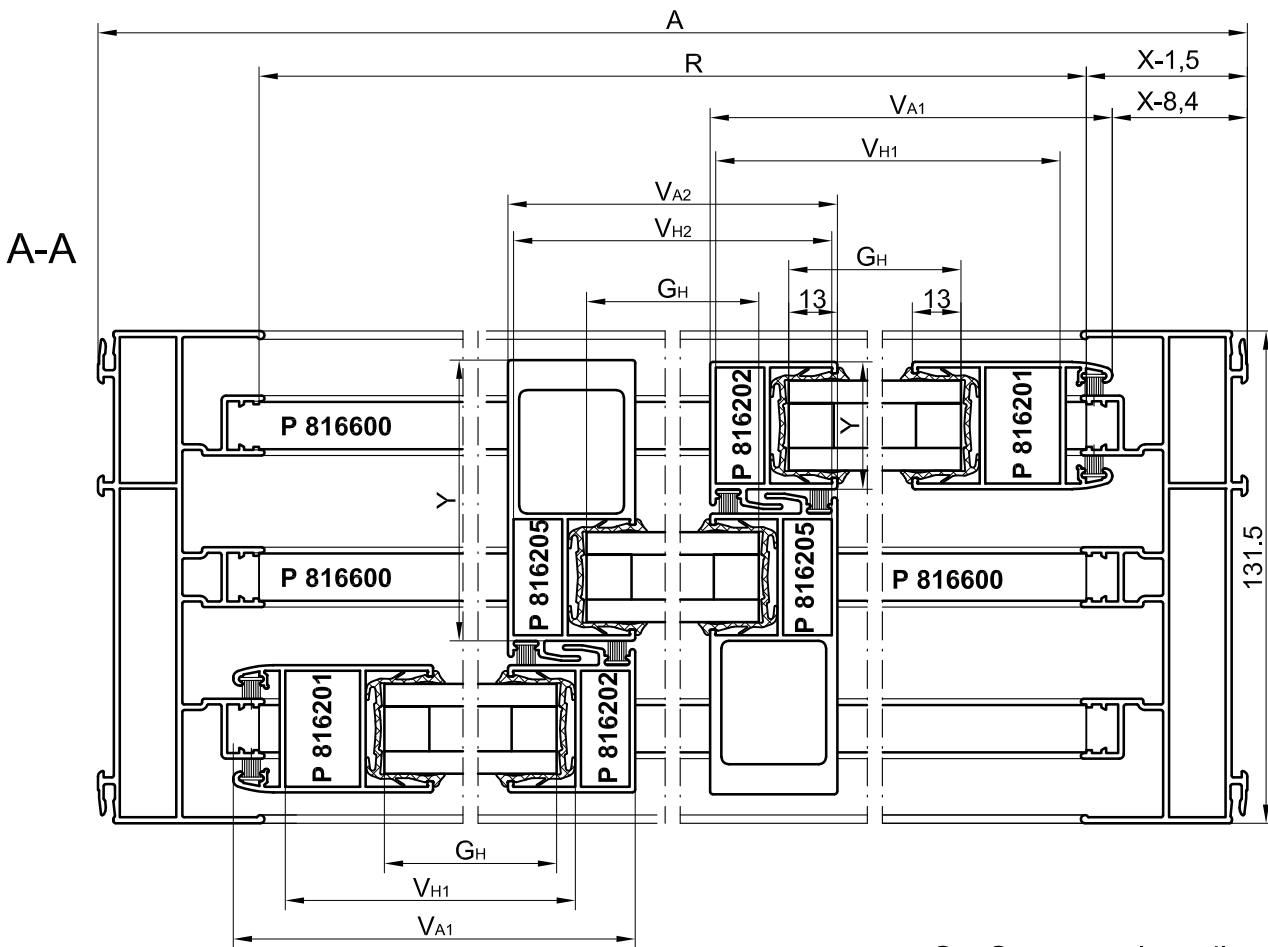
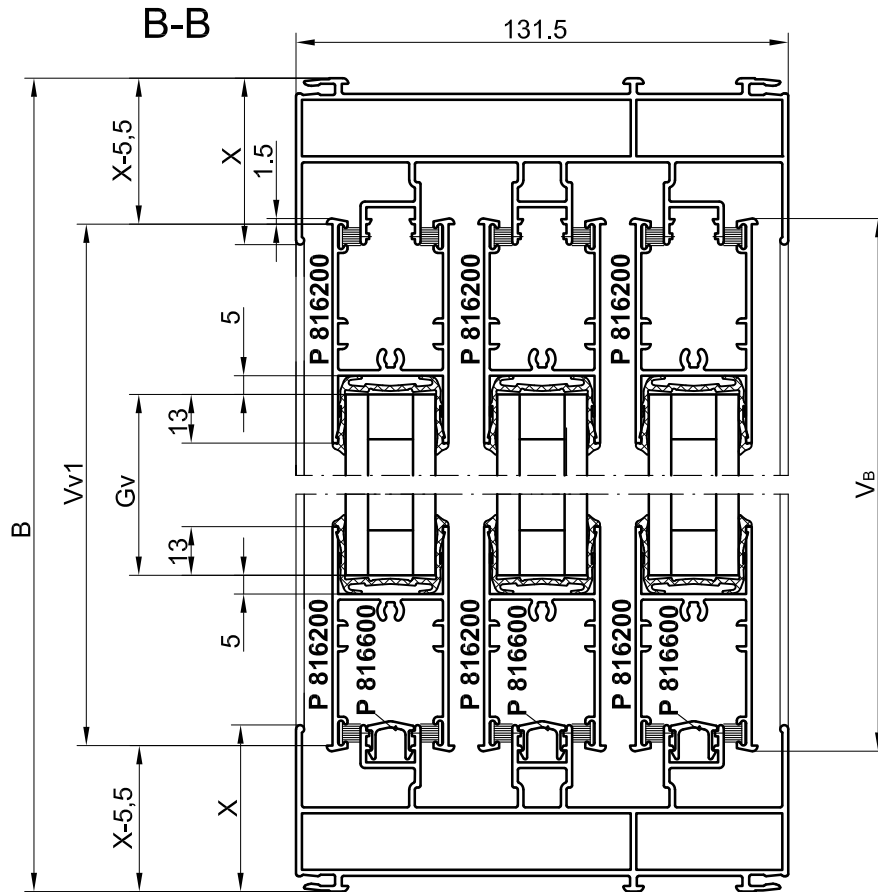

G_v, G_H = see glass dimensions

C-C

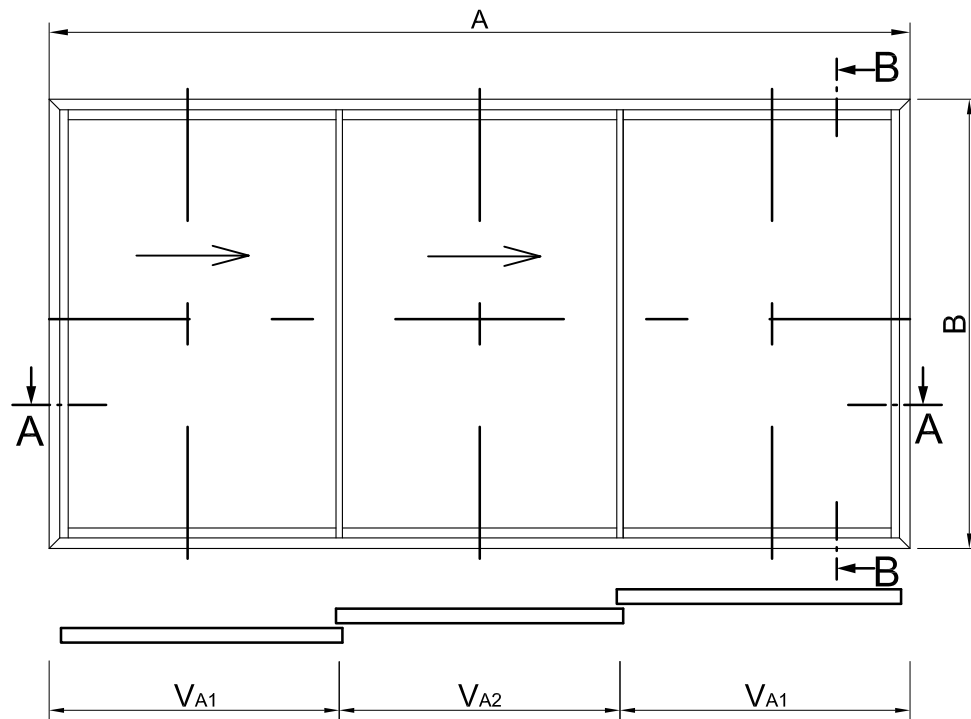

Description	Part no.	X
Frame 44.5	P 816109	44.5
Frame 56.5	P 816110	56.5

Description	Part no.	Y
vent profile vertical (labyrinth side)	P 816202	34
vent profile vertical (labyrinth side)	P 816204	59
vent profile vertical (labyrinth side)	P 816205	75
vent profile vertical (labyrinth side)	P 816206	85

Description	Part no.	Calculation	Number	Cut
frame horizontal	see profile table	$A = \text{horizontal element dimension}$	2x	
frame vertical	see profile table	$B = \text{vertical element dimension}$	2x	
vent horizontal		$V_{A1} = (A - 2x + 104.2) / 3$		
vent horizontal		$V_{A2} = (A - 2x + 104.2) / 3 - 19.4$		
vent vertical		$V_B = B - (2 * X) + 14$		
vent profile horizontal	P 816200	$V_{H1} = (A - 2x + 104.2) / 3 - 15.4$	4x	
vent profile horizontal	P 816200	$V_{H2} = (A - 2x + 104.2) / 3 - 22.4$	2x	
vent profile vertical (lock side)	P 816201	$V_{V1} = B - (2 * X) + 11$	2x	
vent profile vertical (labyrinth side)	see profile table	$V_{V2} = B - (2 * X) + 11$	4x	
running rail	P 816600	$R = A - (2 * X) + 3$	3x	

159002000

B-B

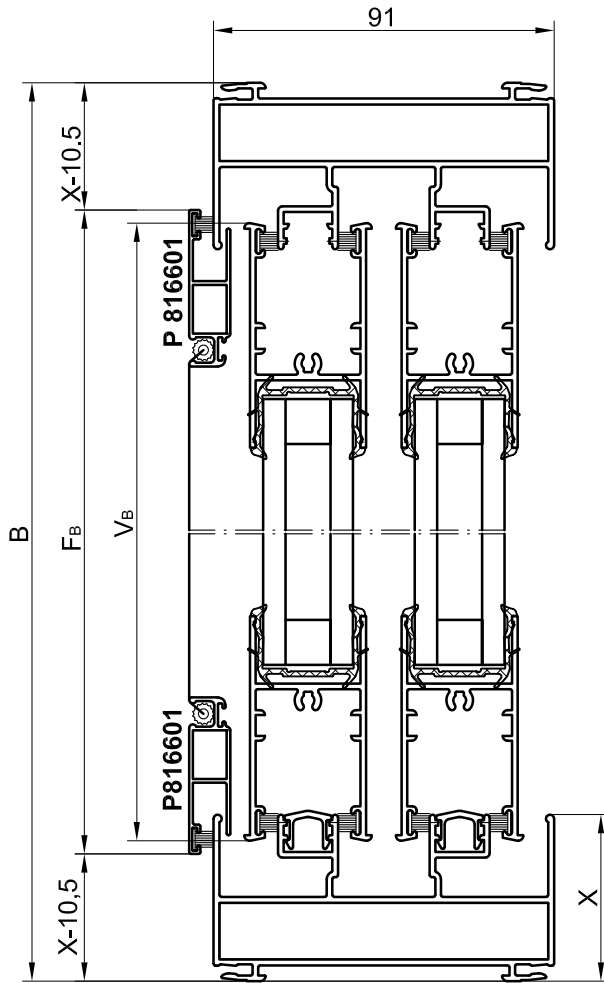

A-A

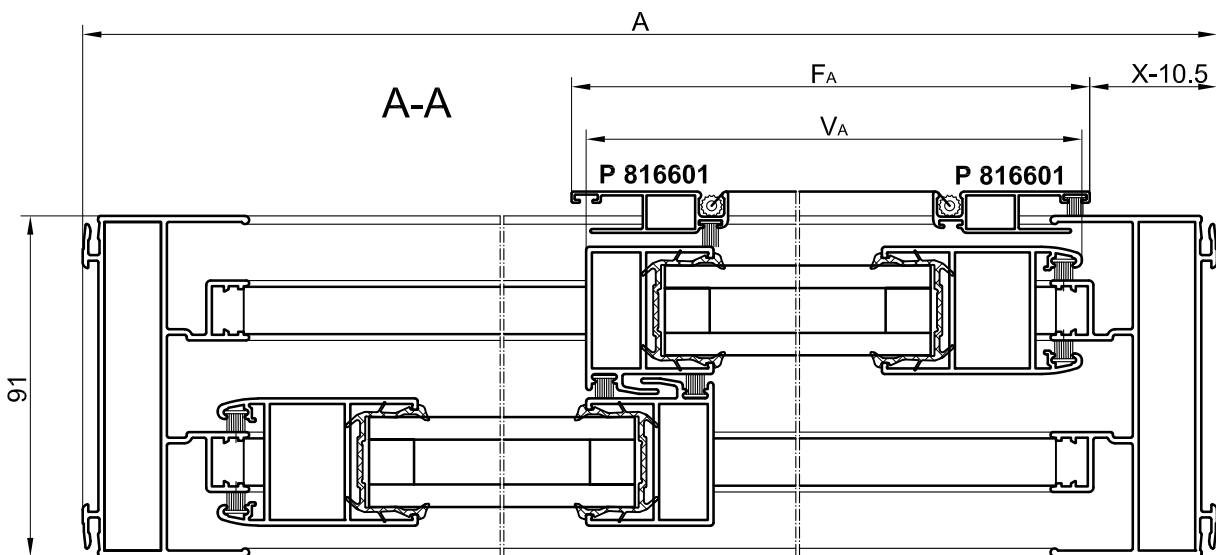

160000800

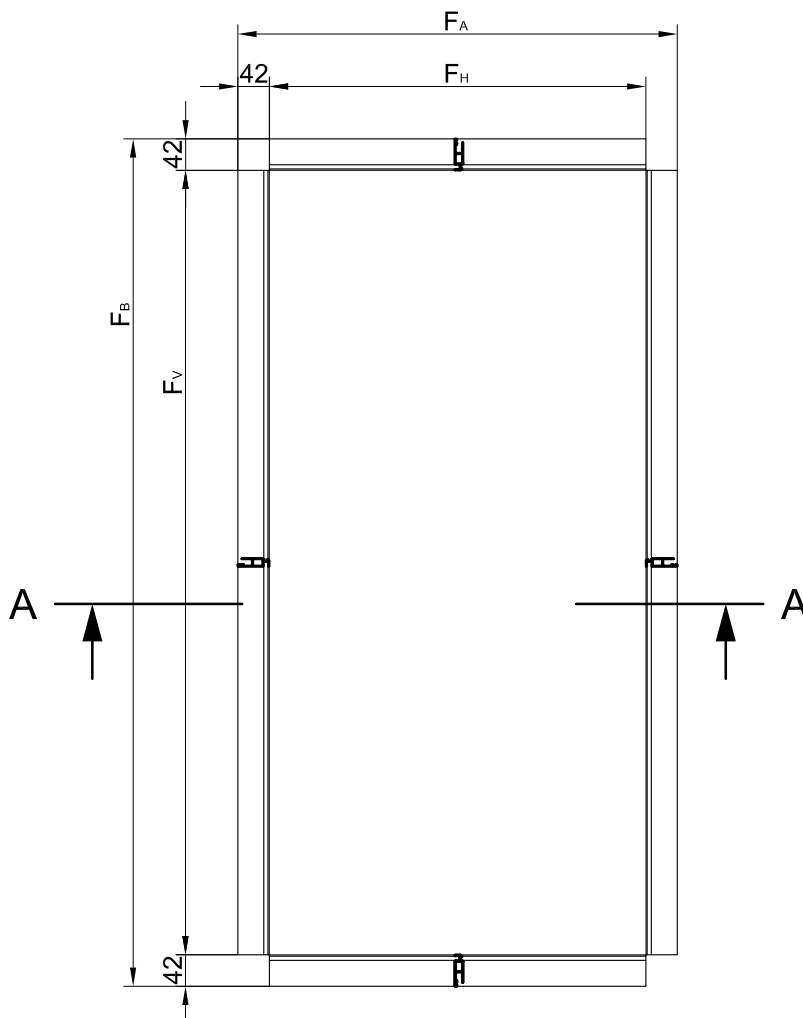

Description	Part no.	Calculation	Number	Cut
frame horizontal		$A =$ horizontal element dimension		
frame vertical		$B =$ vertical element dimension		
vent horizontal		$V_A =$ horizontal vent dimension		
vent vertical		$V_B =$ vertical vent dimension		
fly screen horizontal		$F_A = V_A + 6$		
fly screen vertical		$F_B = V_B + 7$		
fly screen profile horizontal	P 816201	$F_H = F_A - 84$	2x	
fly screen profile vertical	P 816201	$F_V = F_B - 84$	2x	

161000100

Holes for corner brackets

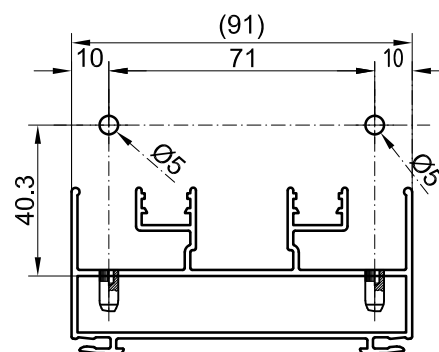
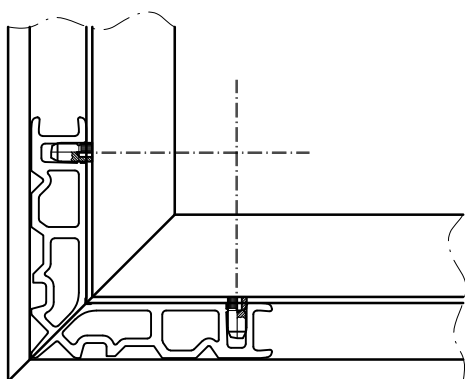
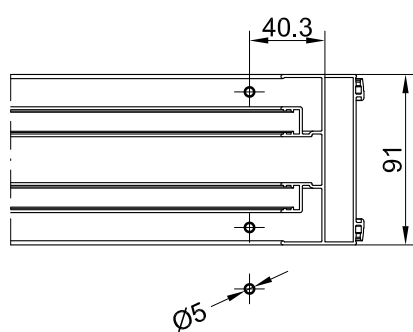

Drilling scheme for corner deat

Holes for corner brackets

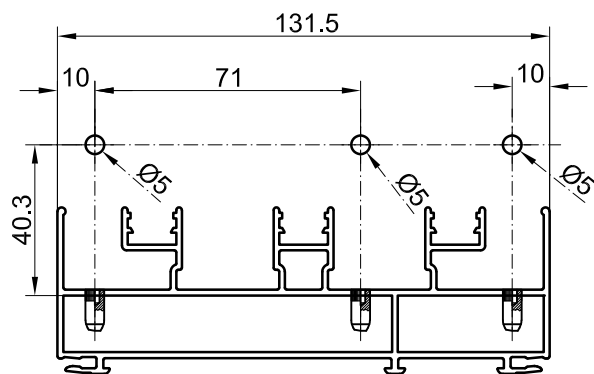
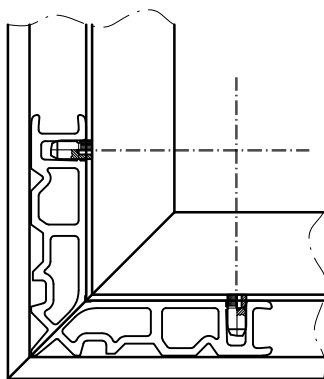
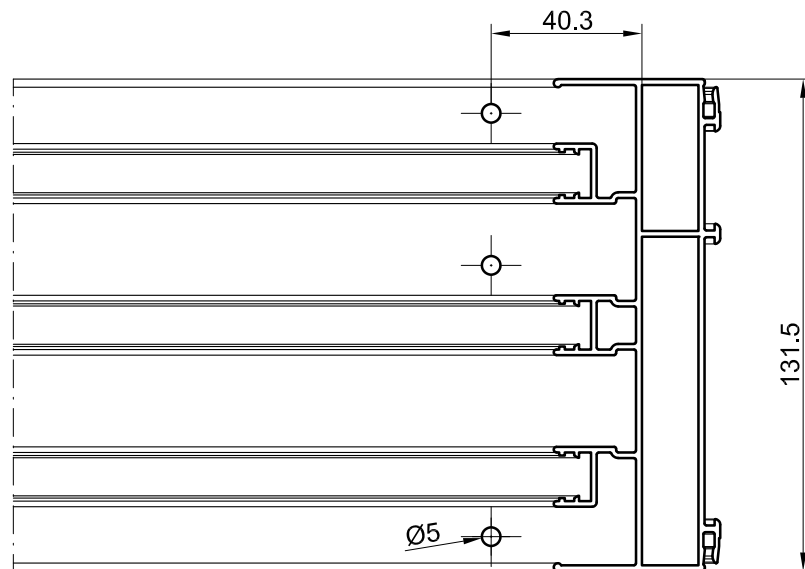

Drilling scheme for corner cleat

163002100

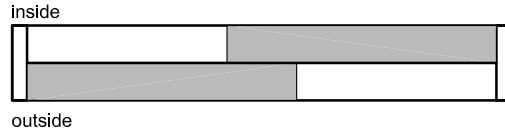
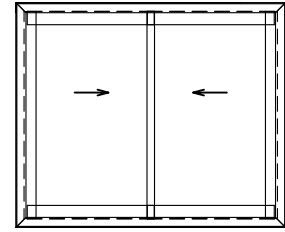

Processing frame

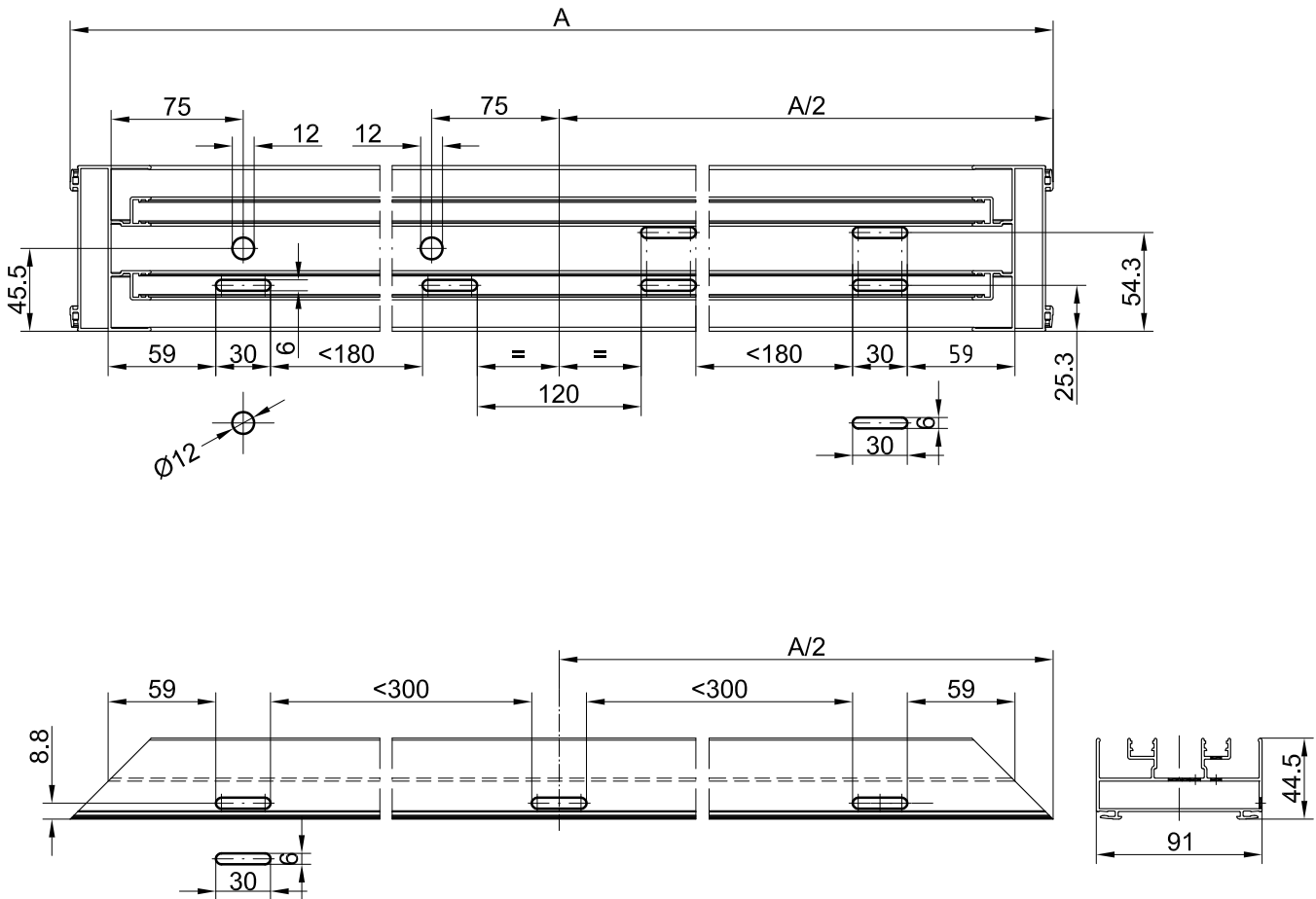

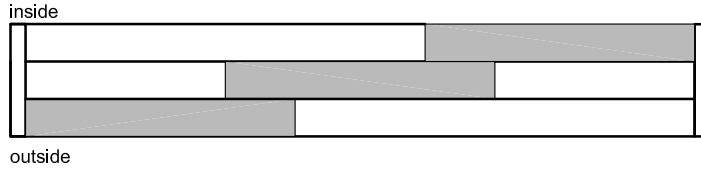
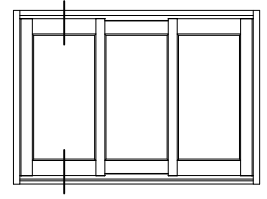

Processing frame

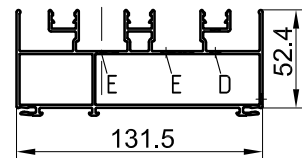
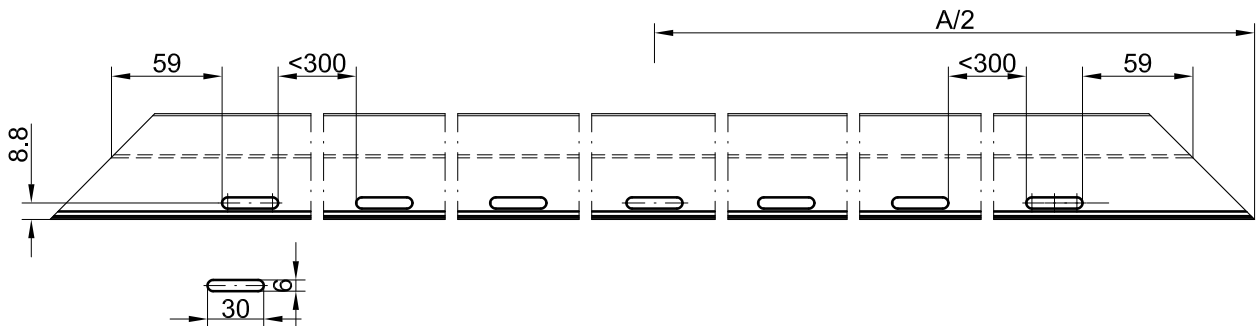
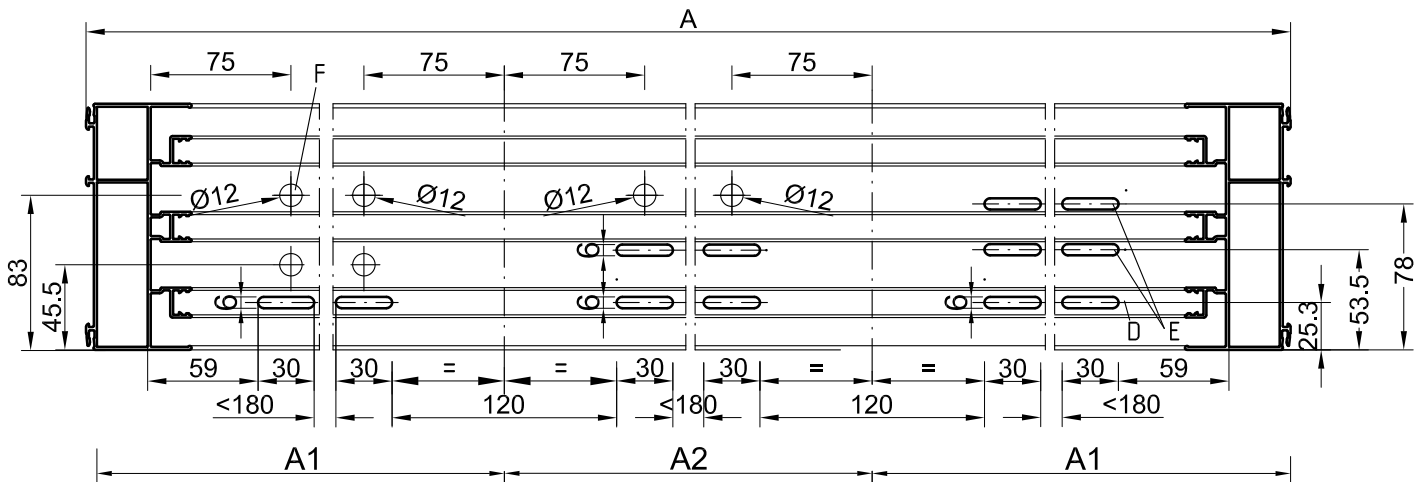

165002200

Processing frame

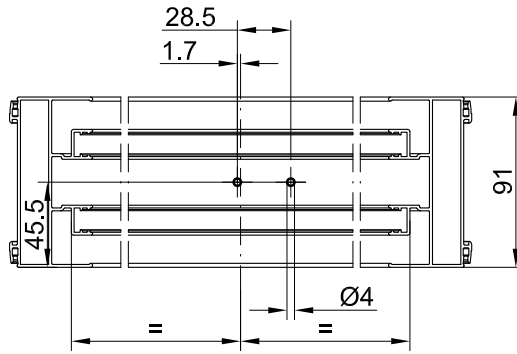

On the surface

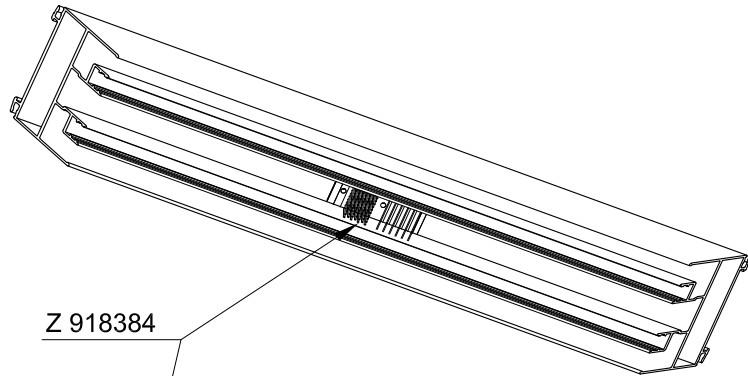

At the bottom

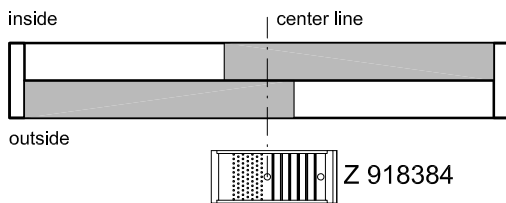
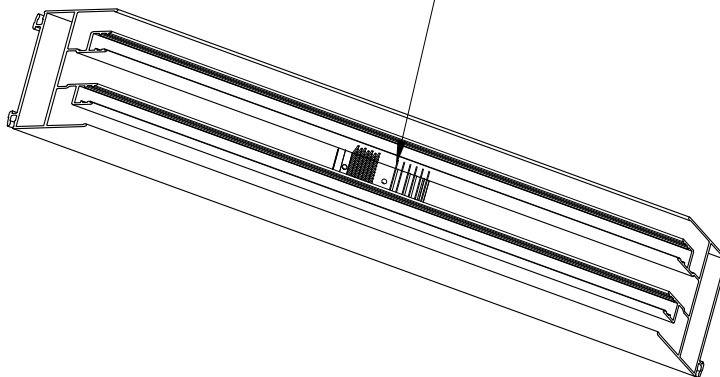

166001300

Processing for mullion

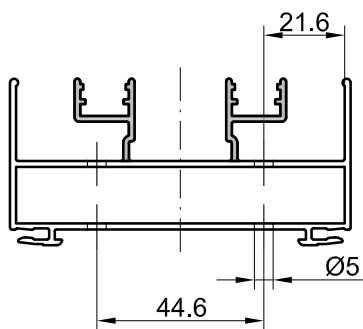
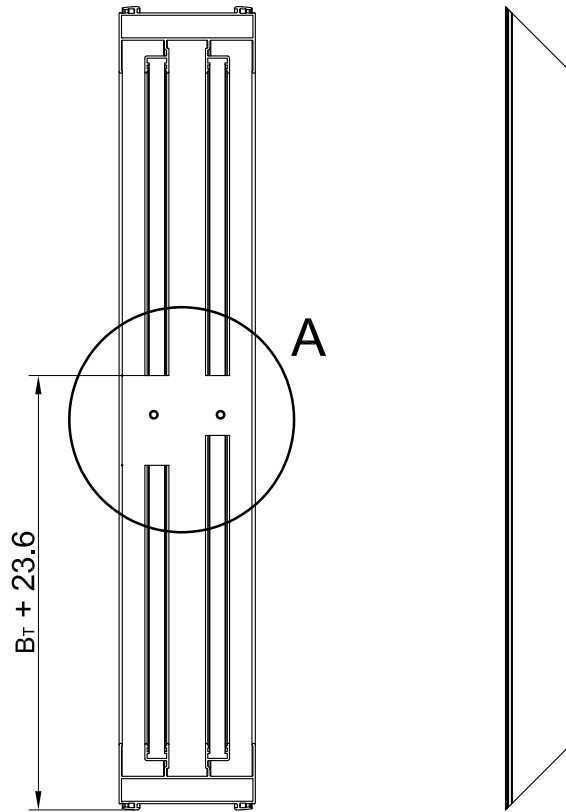

left, as drawn
right, mirror image

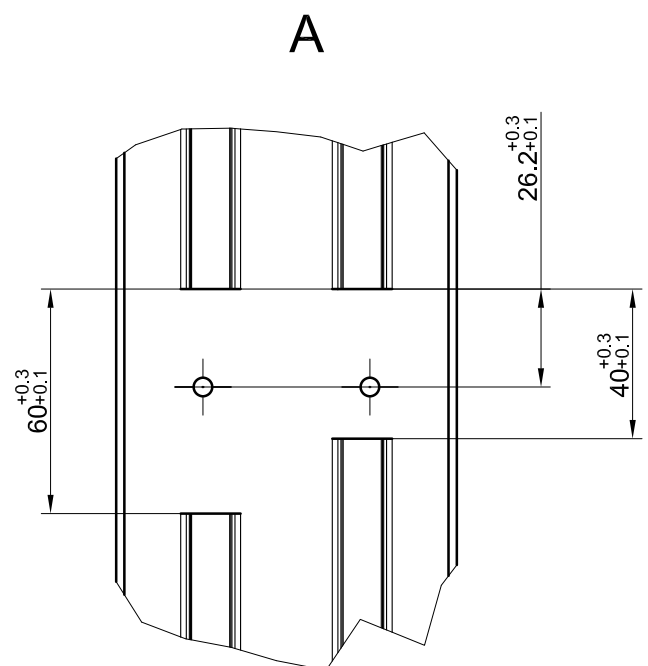

167001400

Processing for mullion

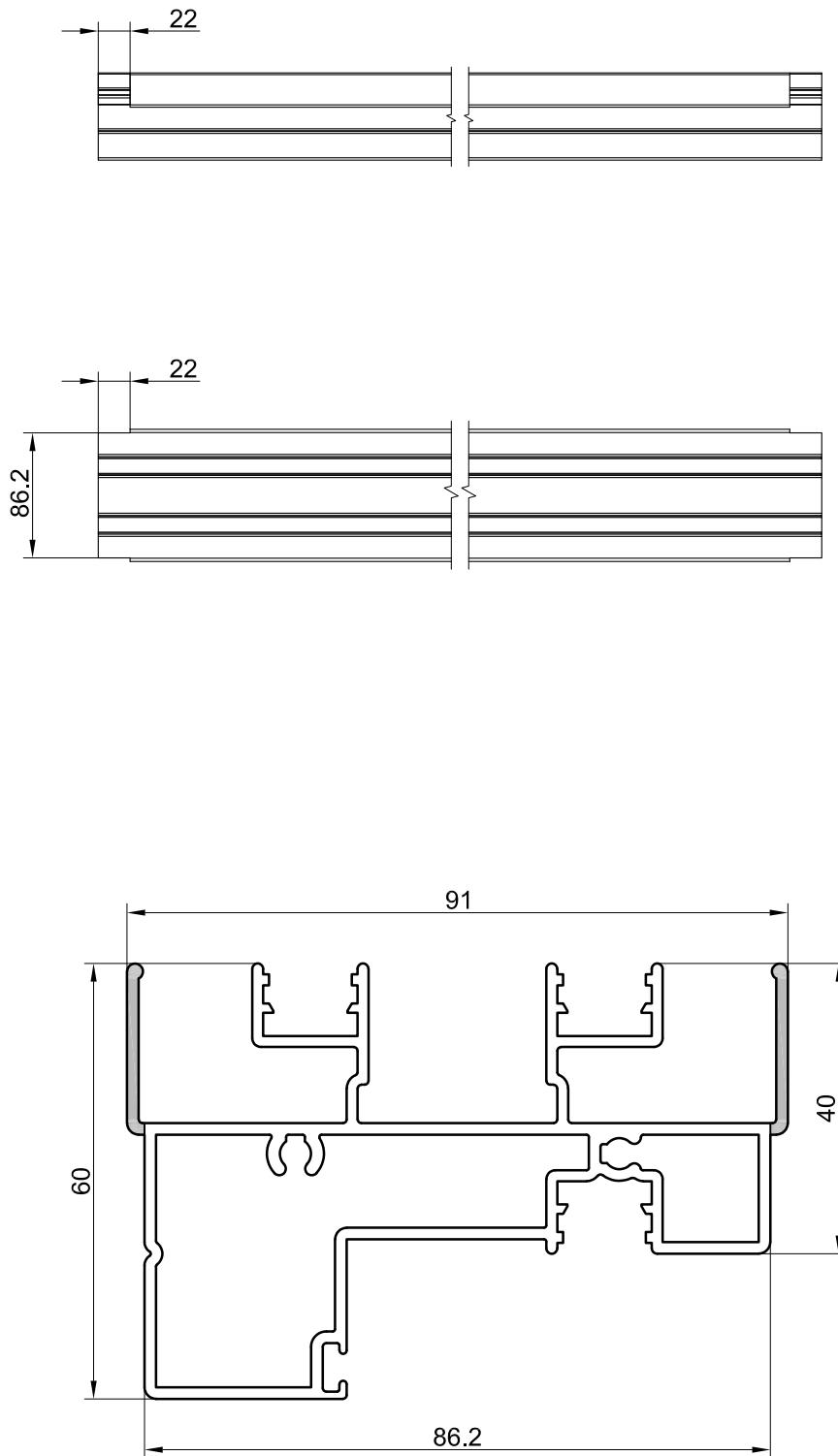

168001500

Processing for mullion

inside

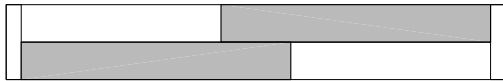

outside

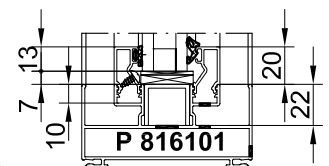
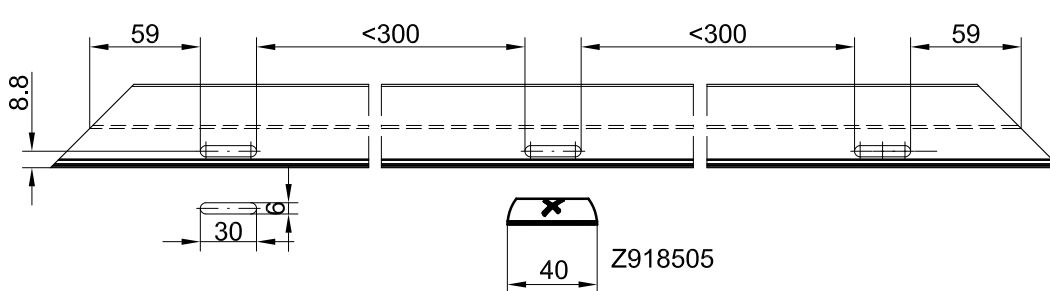
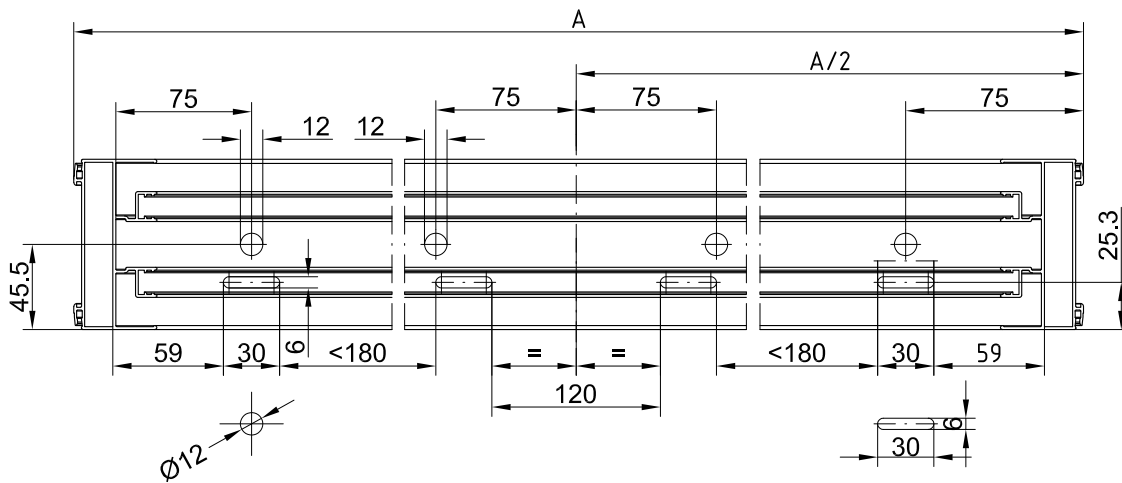
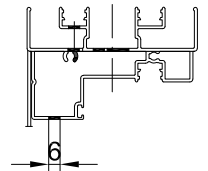
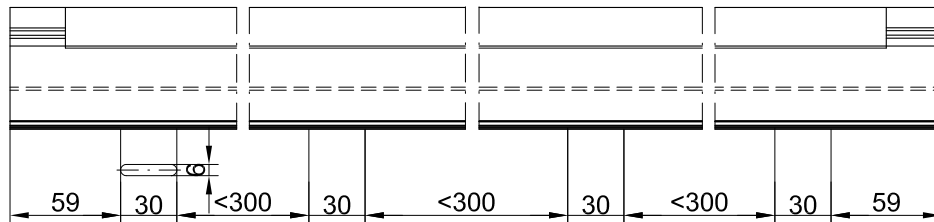
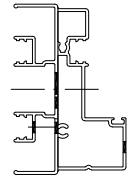
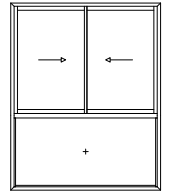
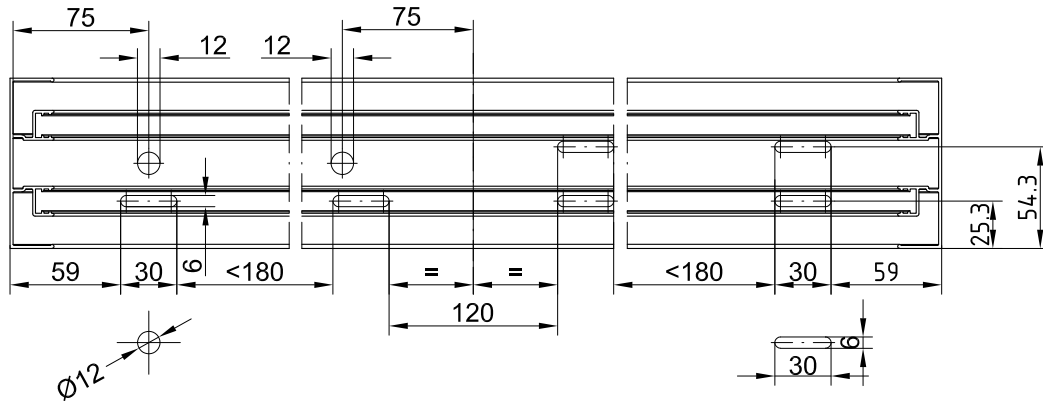

169001600

Cutting and notching in sash profile and secondary sash profile

P 816201

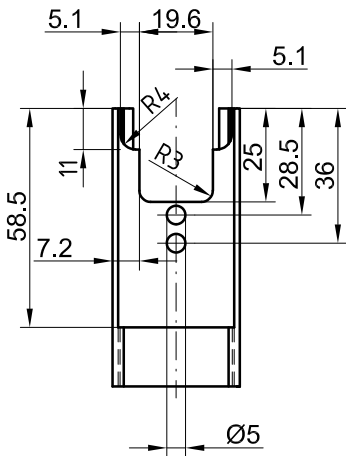
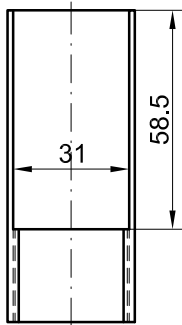
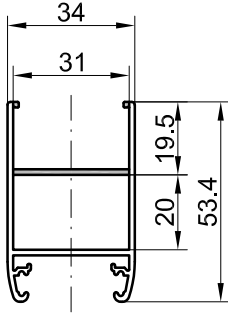

P 816202

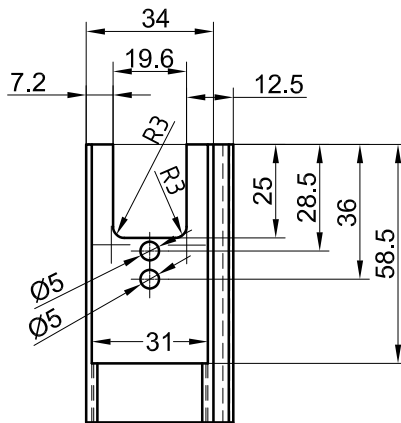
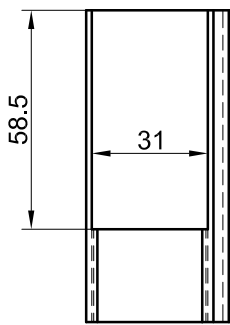
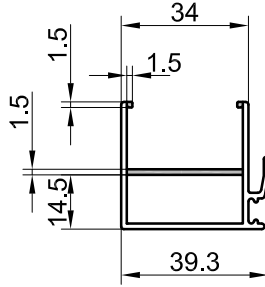

P 816204

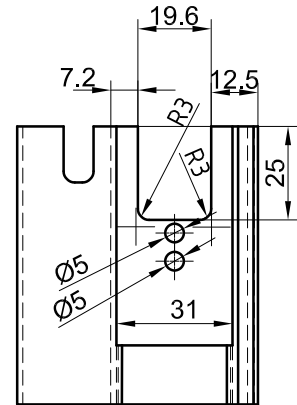
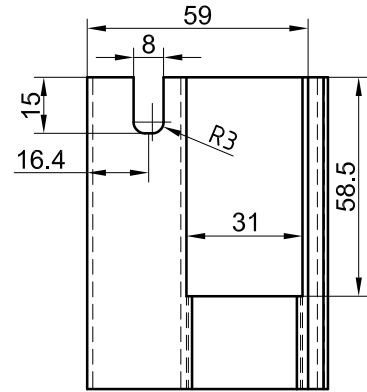
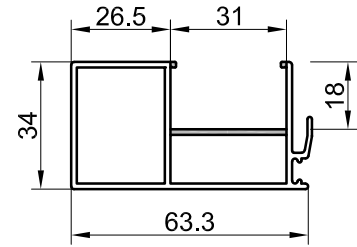

P 816200

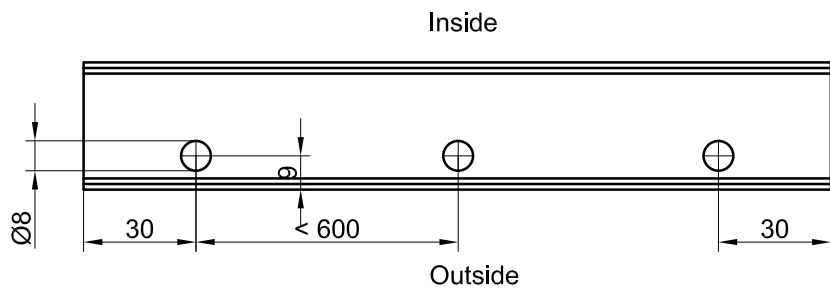
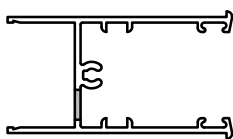

Cutting and notching in sash profile and secondary sash profile

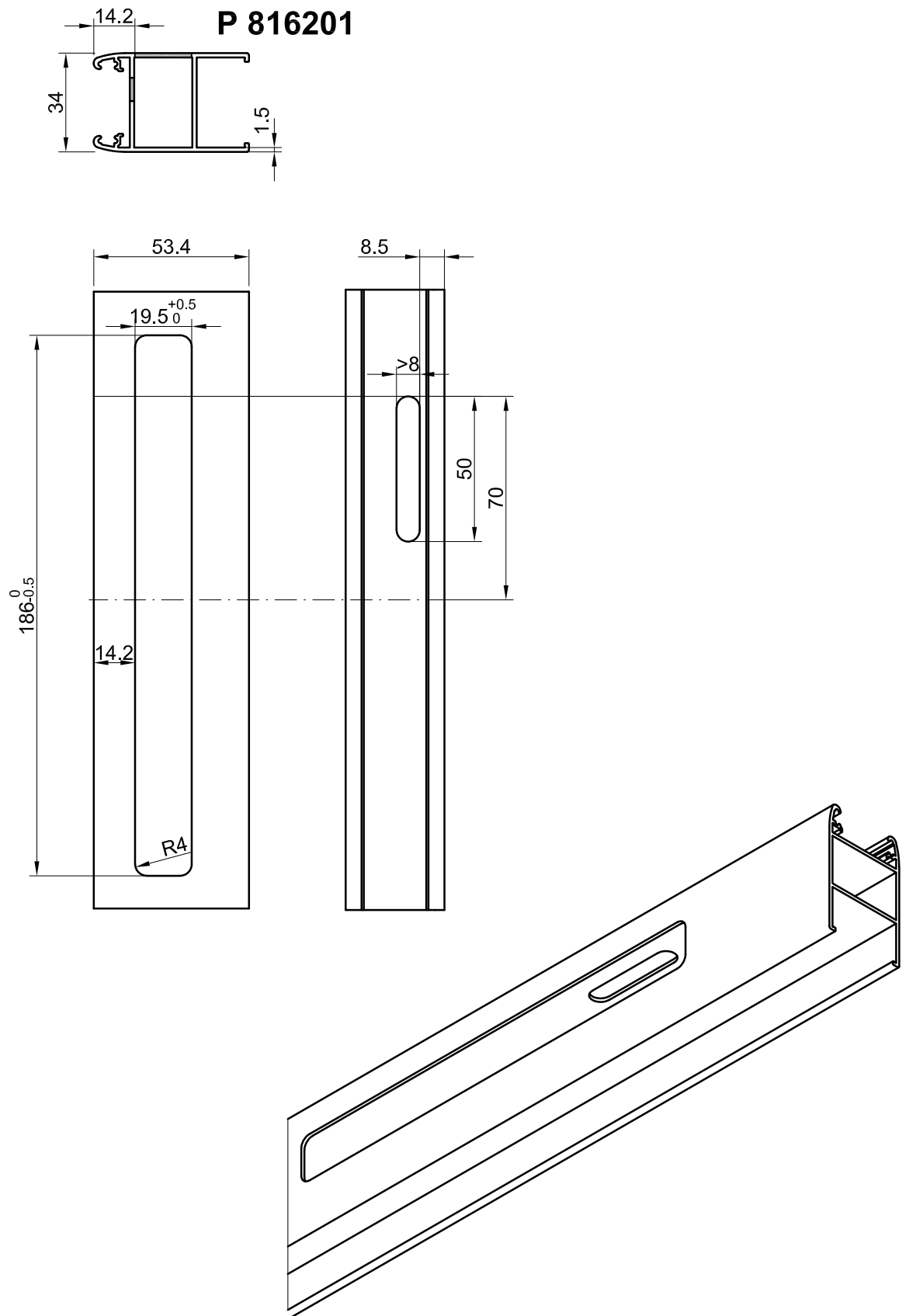

171001800

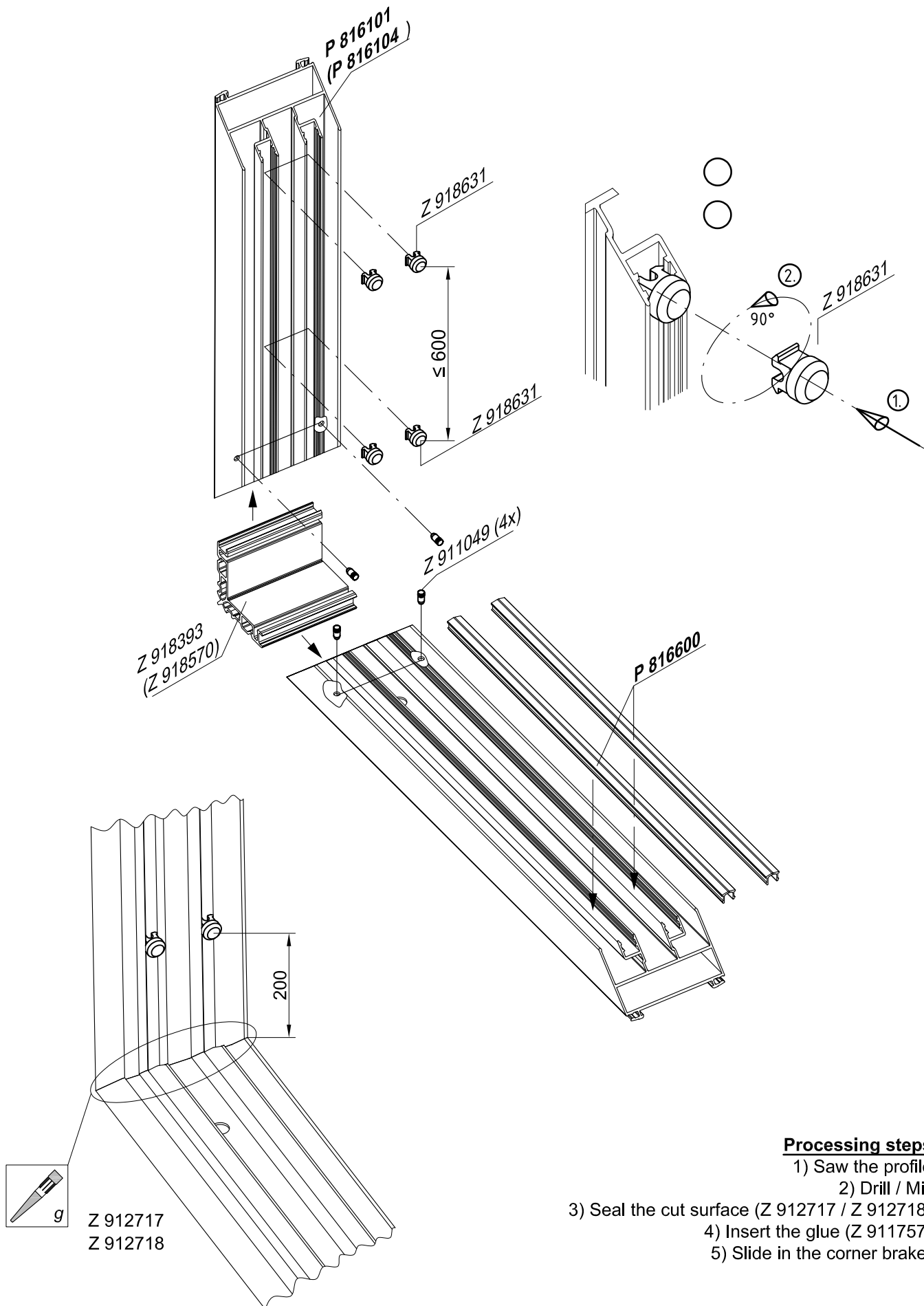

Processing steps

- 1) Saw the profile
- 2) Drill / Mill
- 3) Seal the cut surface (Z 912717 / Z 912718)
- 4) Insert the glue (Z 911757)
- 5) Slide in the corner braket

172001900

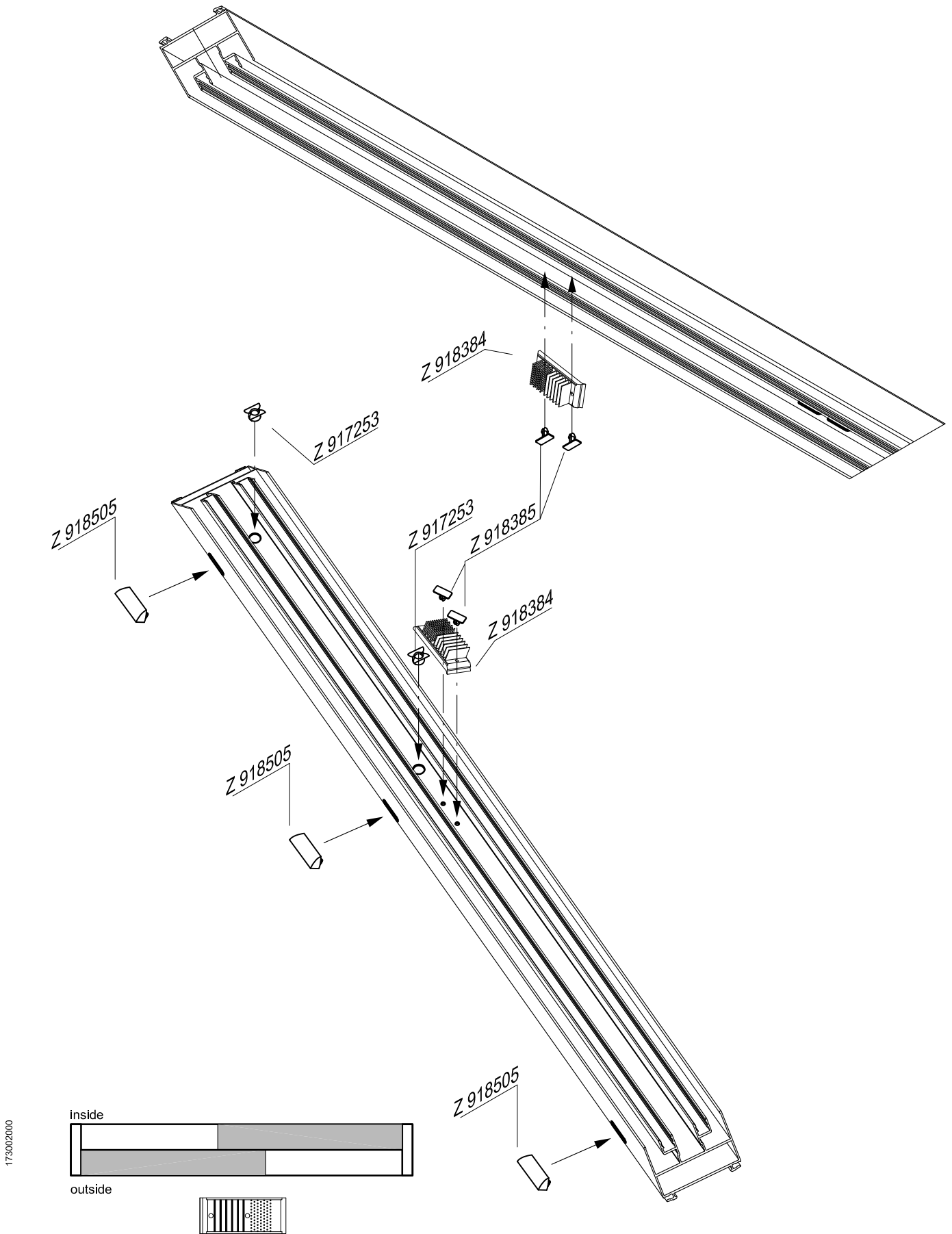

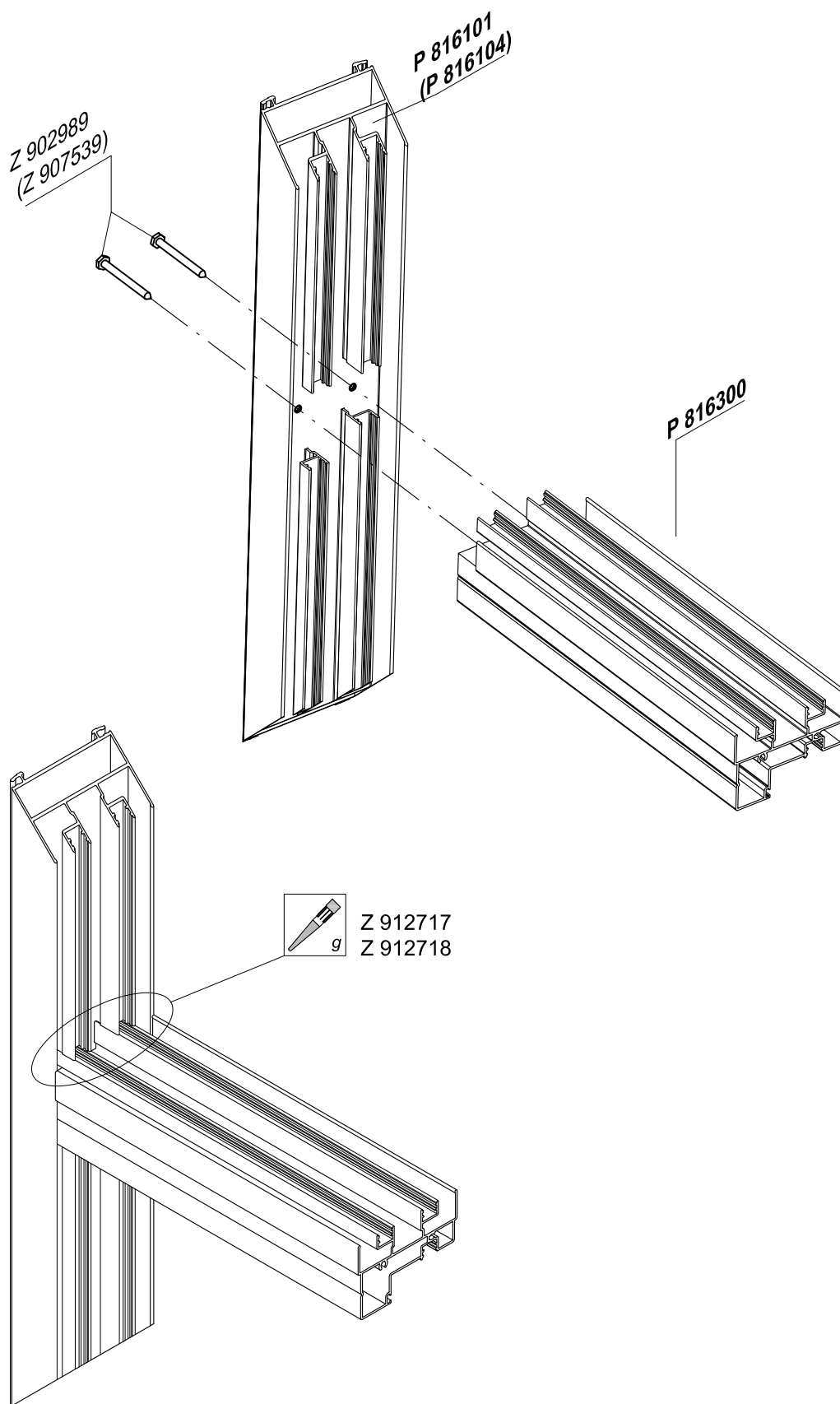

174002100

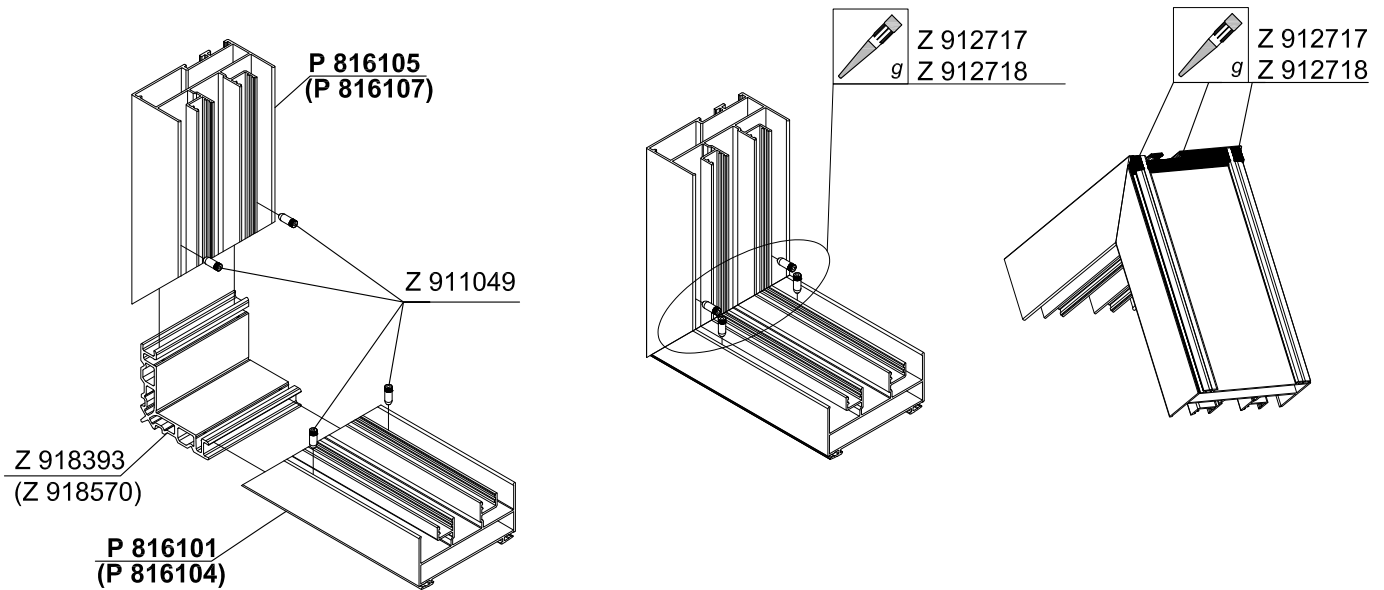

Processing steps

- 1) Saw the profile
- 2) Drill / Mill
- 3) Seal the cut surface (Z 912717 / Z 912718)
- 4) Insert the glue (Z911737)
- 5) Slide in the corner bracket

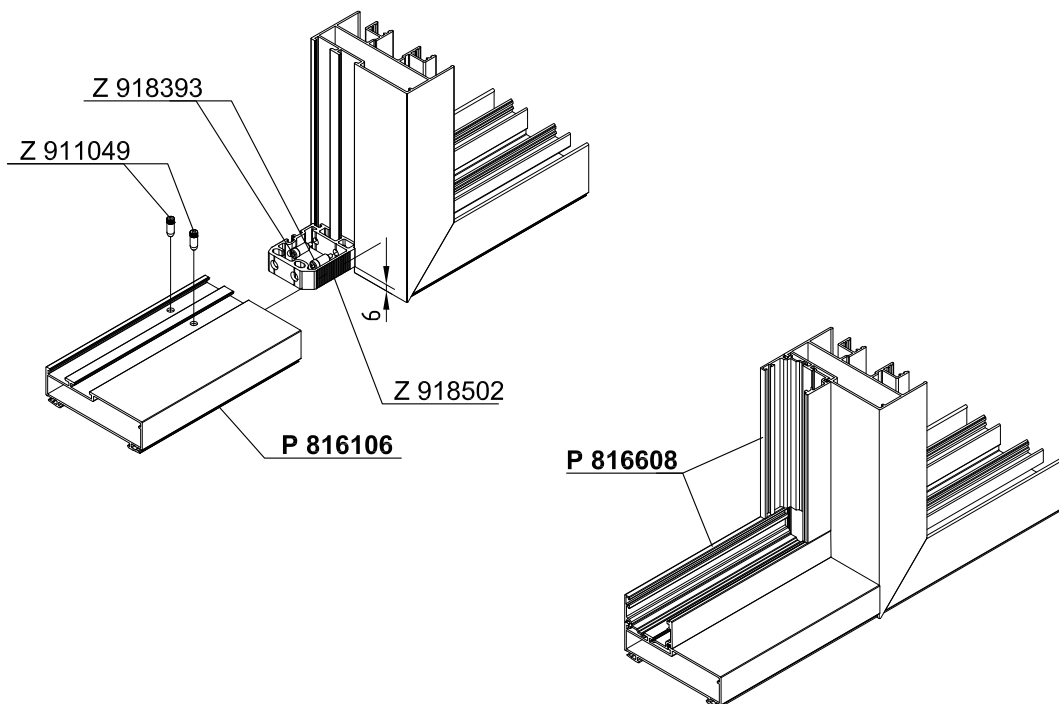

175002200

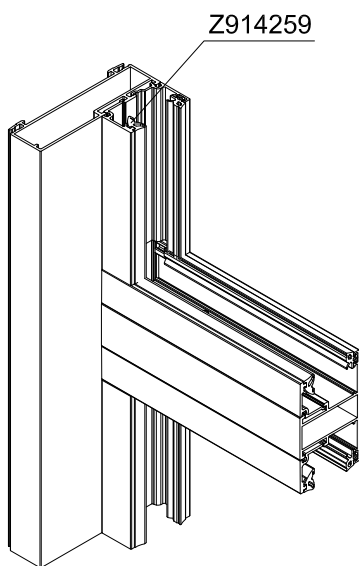
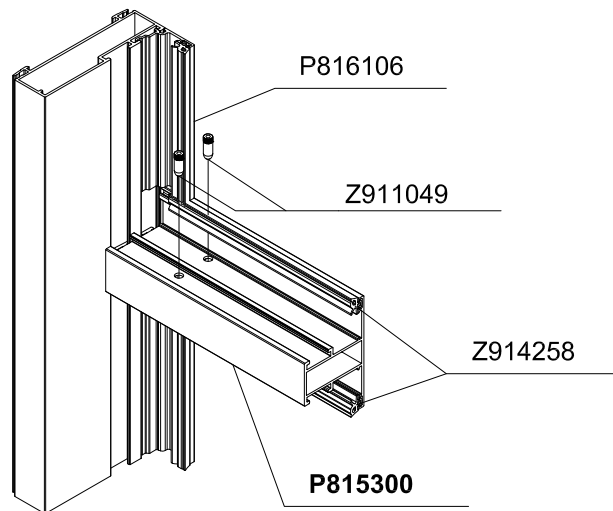
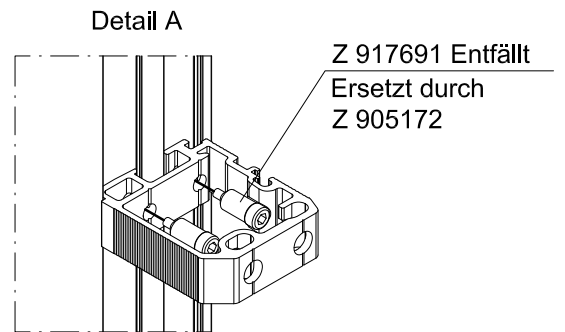
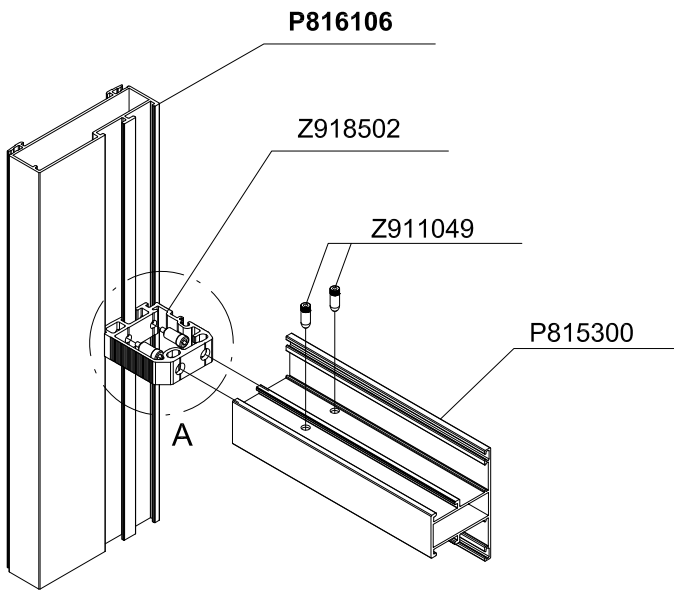

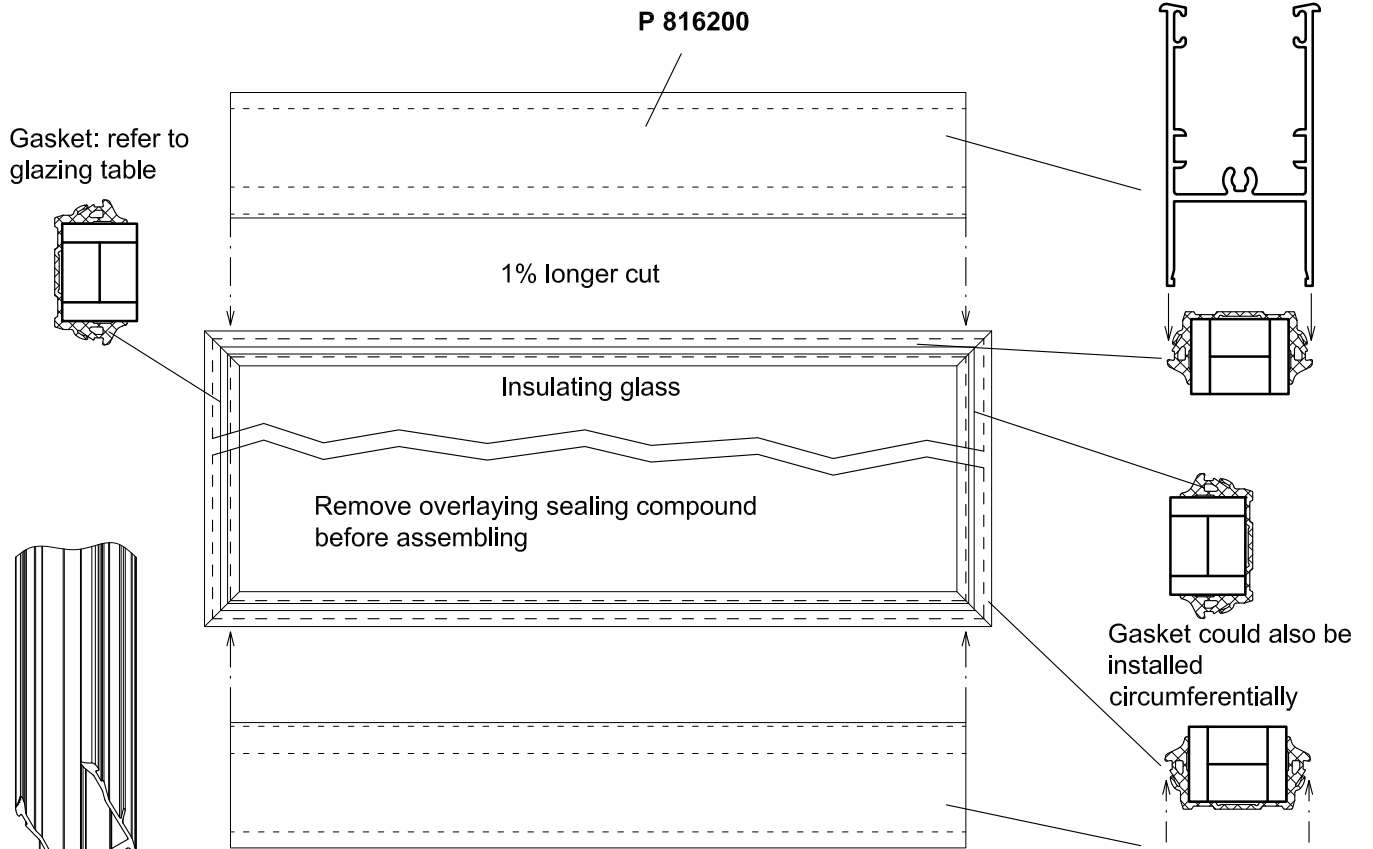

With sash heights over 2000mm, the gasket should be cut away in the handle area, to enable silicone mastic to be injected between sash and glass

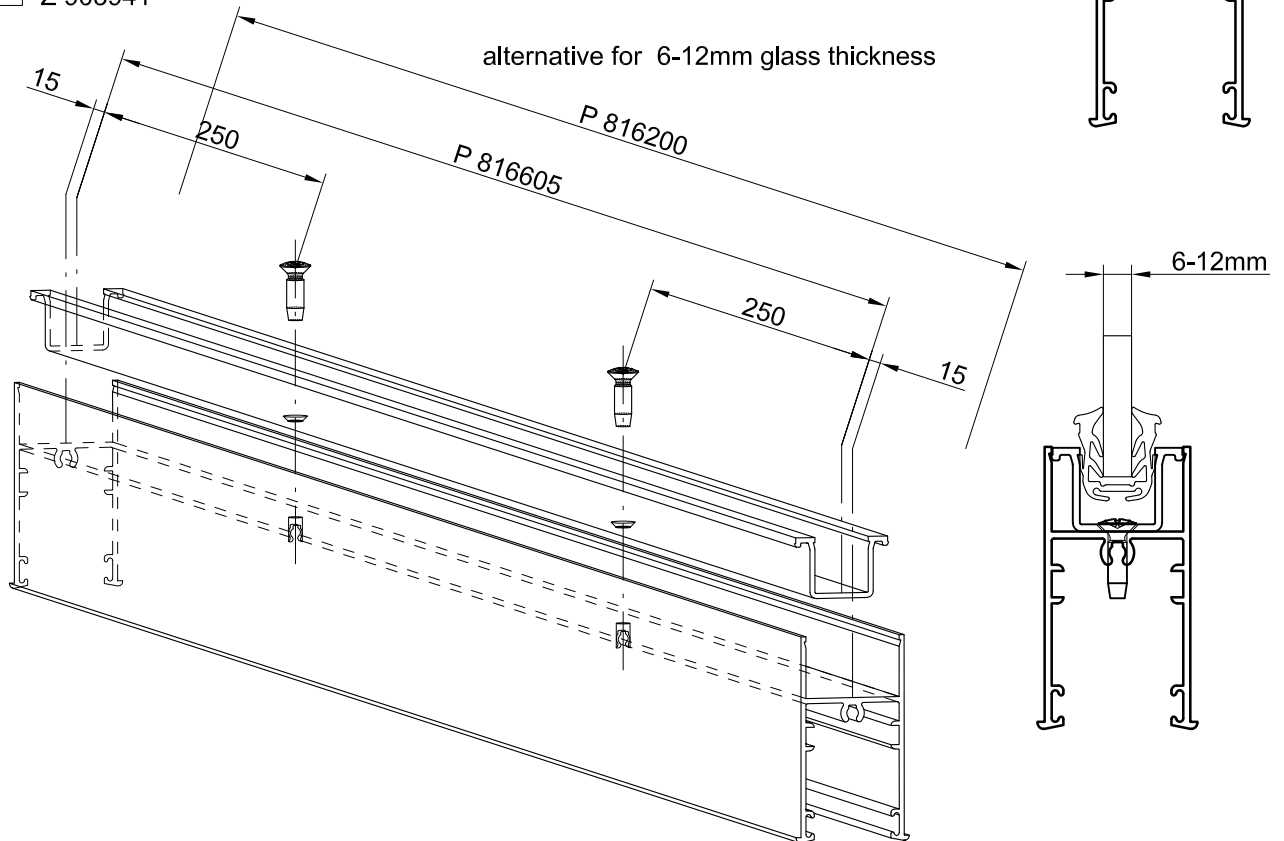
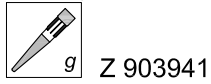

177002400

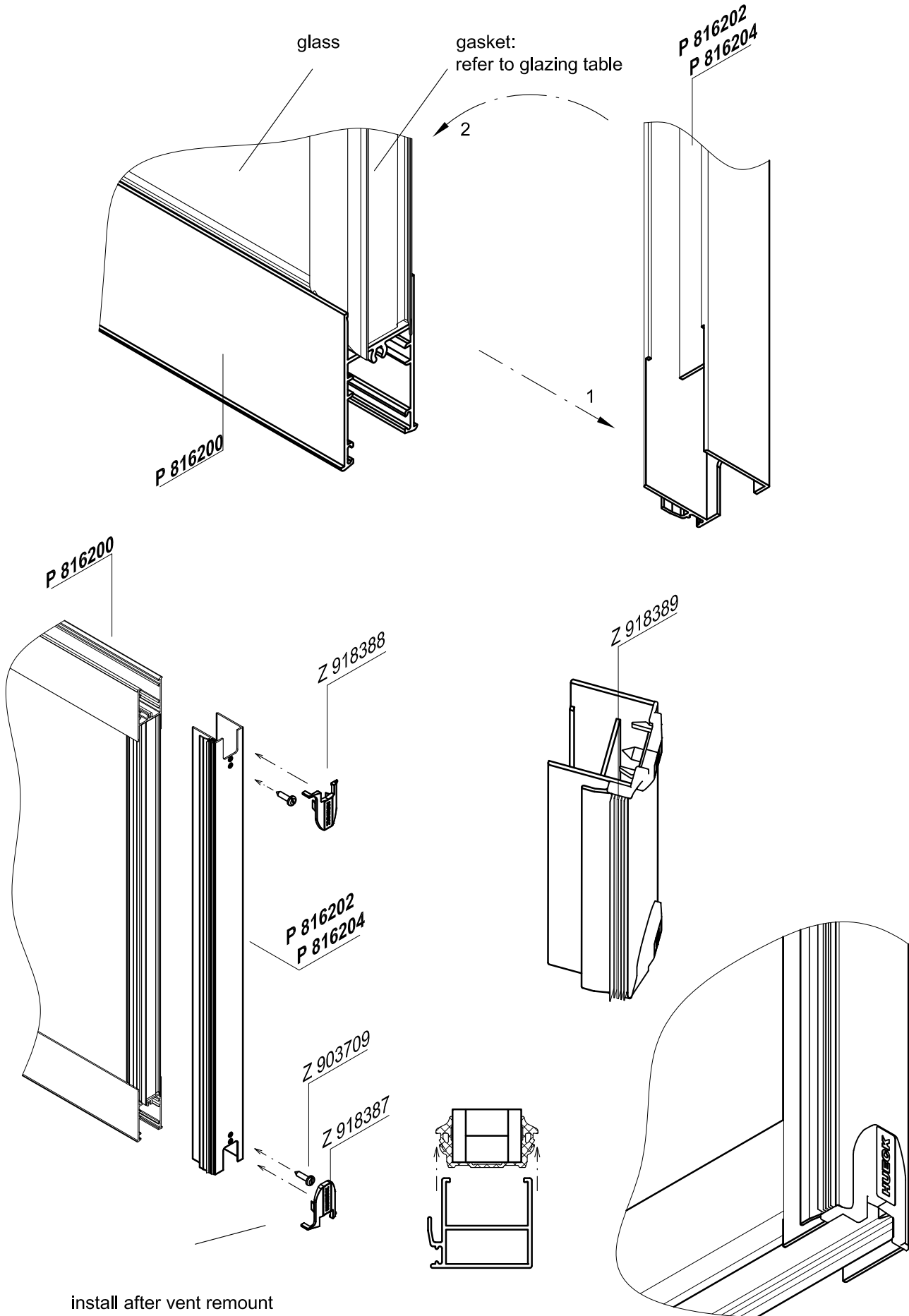

install after vent remount

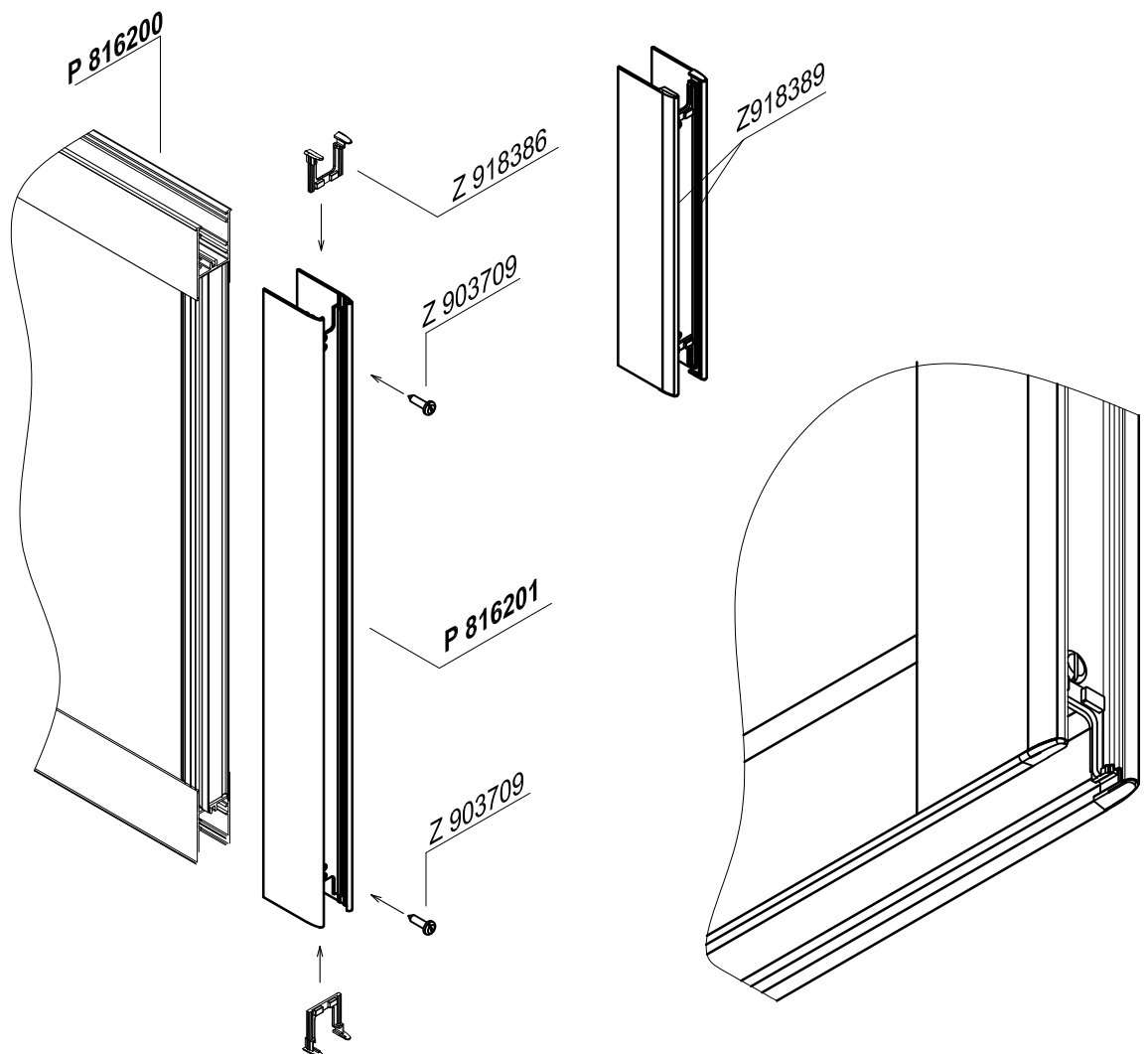
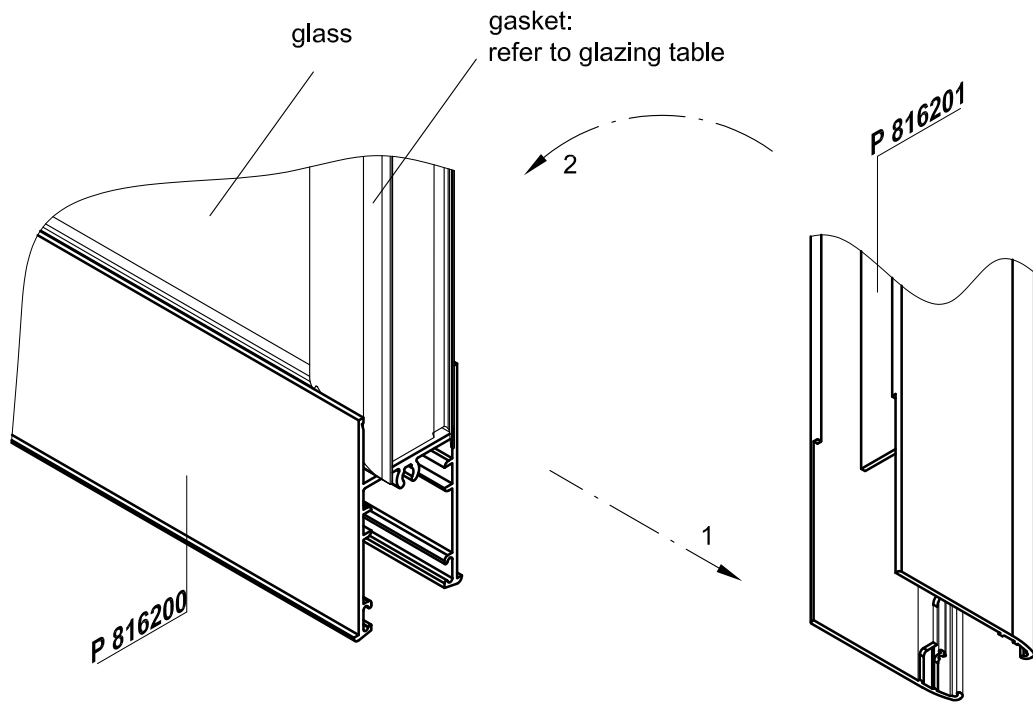

179002600



Assembly of the labyrinth profil

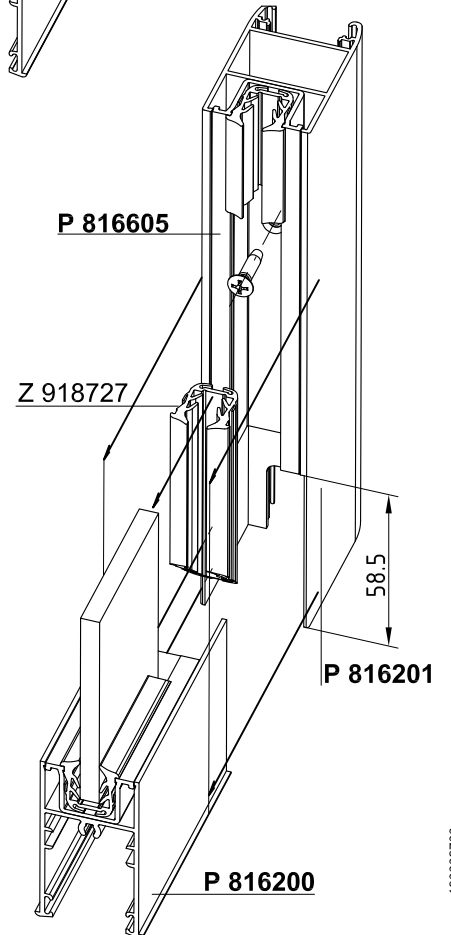
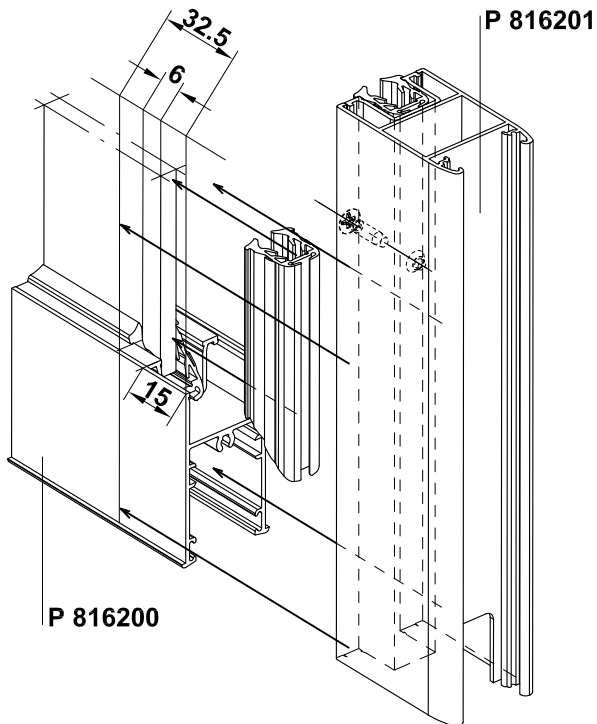
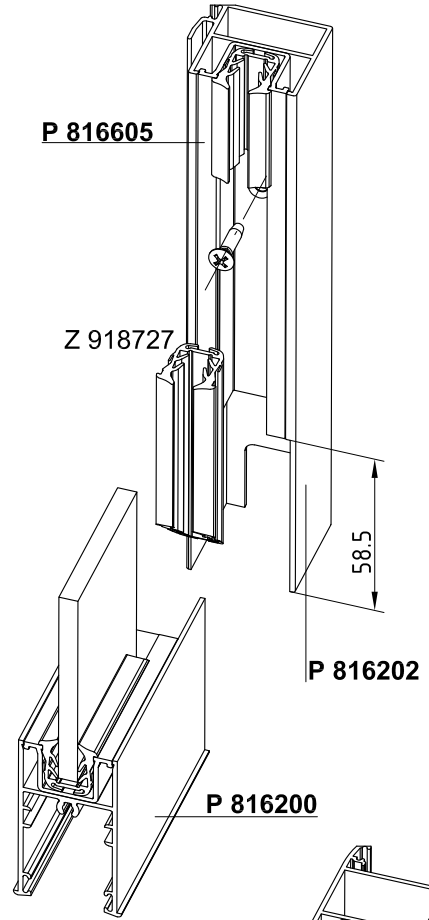
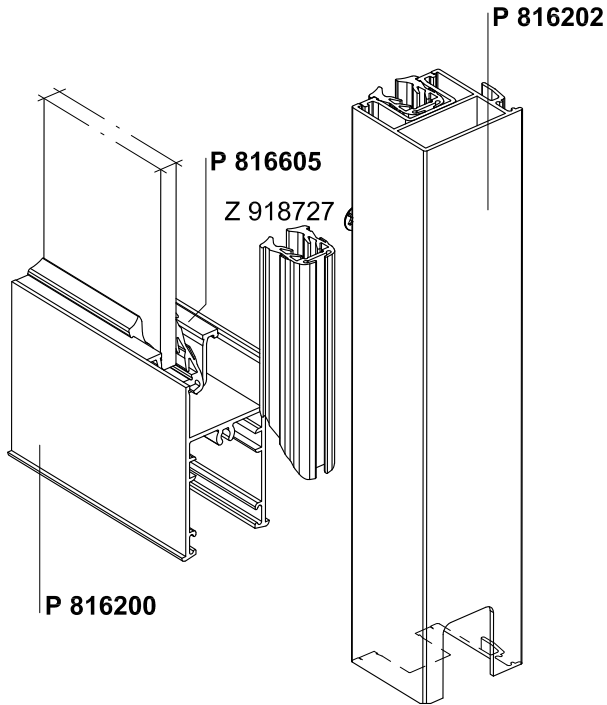

Preparation of the sash

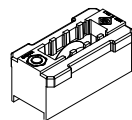
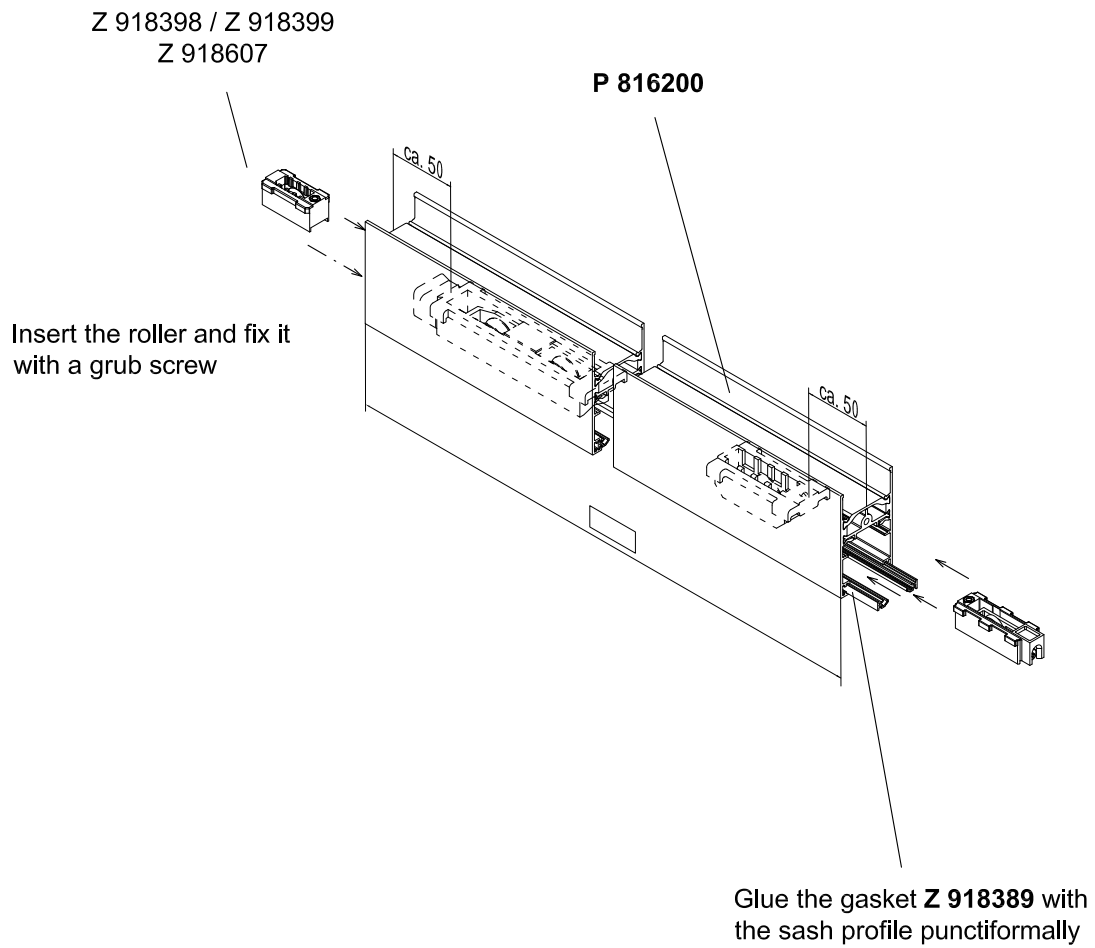

Z 918398

Single roller fixed (sliding)
max. 25 kg / roller

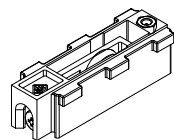

Z 918399

Single roller adjustable (sliding)
max. 20 kg / roller

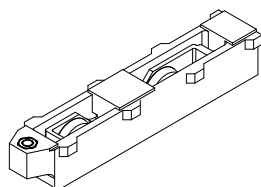

Z 918607

Double roller adjustable (sliding)
max. 50 kg / roller

181002800

Z 1:2
P 816602

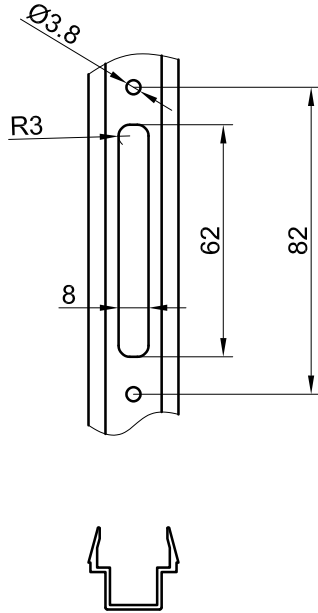

P 816602

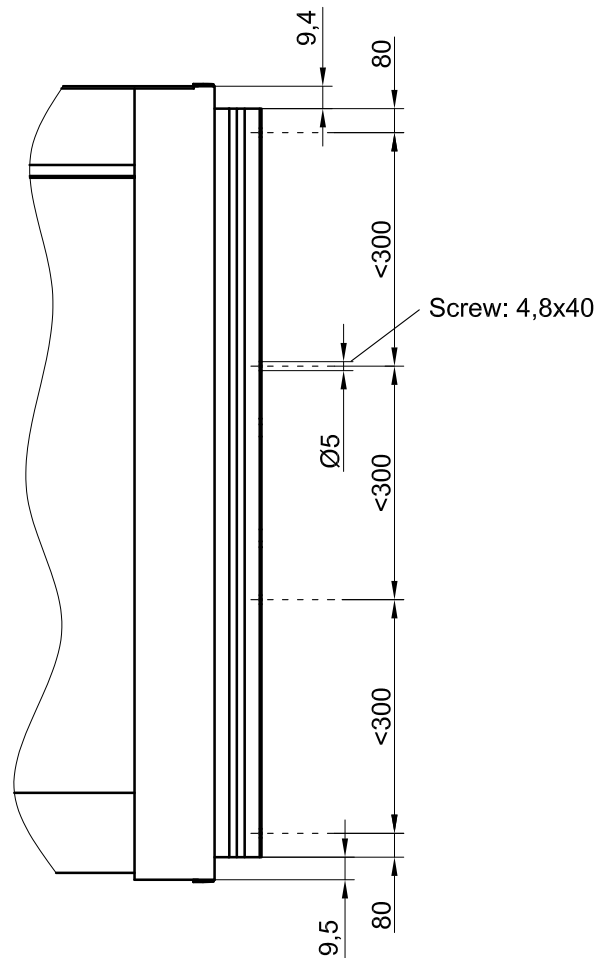
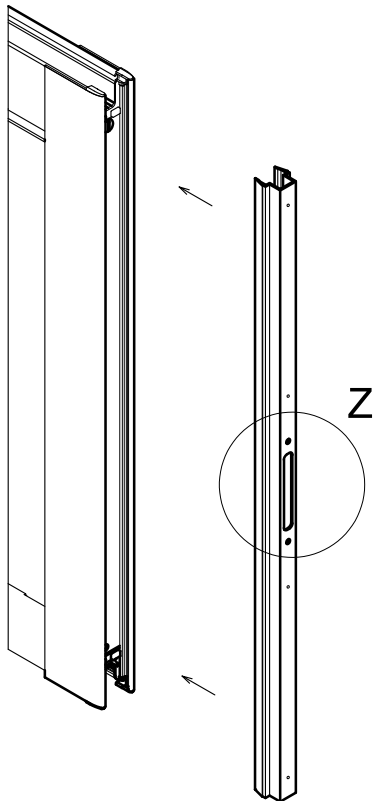
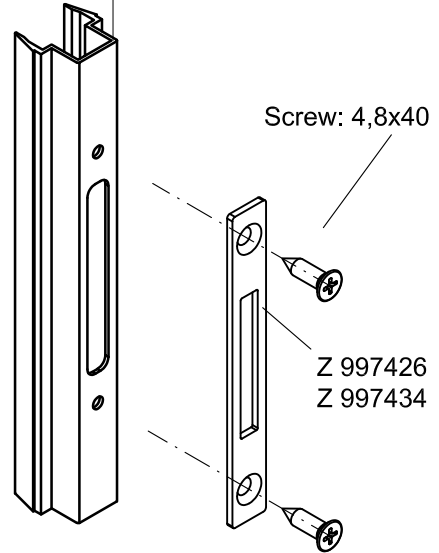

182002900

Apply the "INNER CLICK" as indicated, First insert the lower part (1) then push to fit upper part (2)

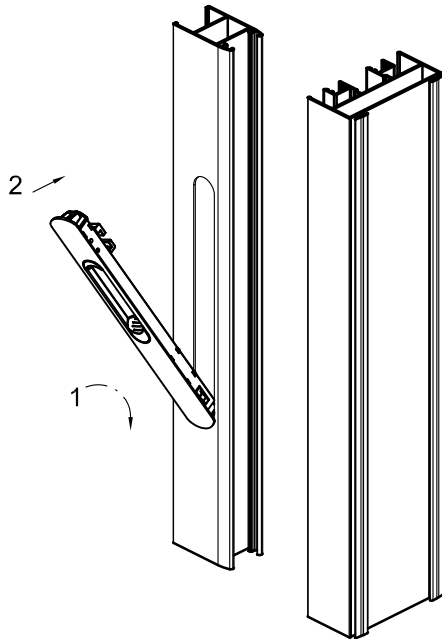

Insert the nib (3) as in figure , the nib head must be at the center of the wing tubularity. Block the nib by fastening the without head screw.

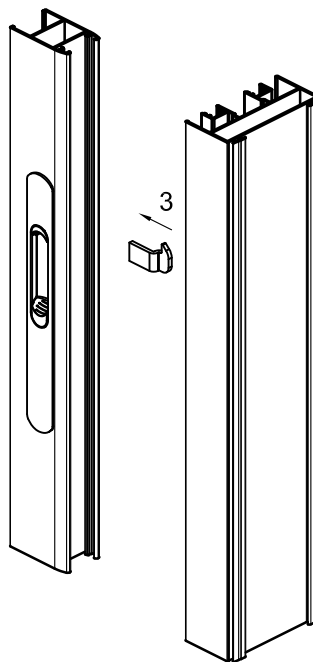

Slide in the backing before assembling full frame and fix the strike plate with it.

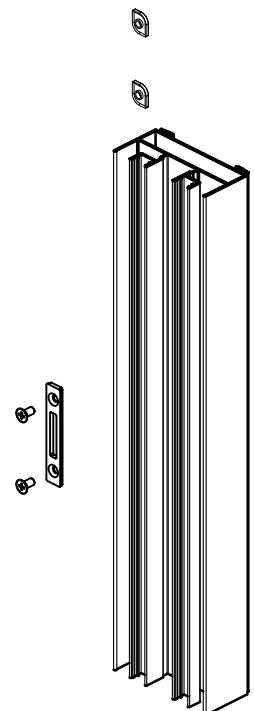

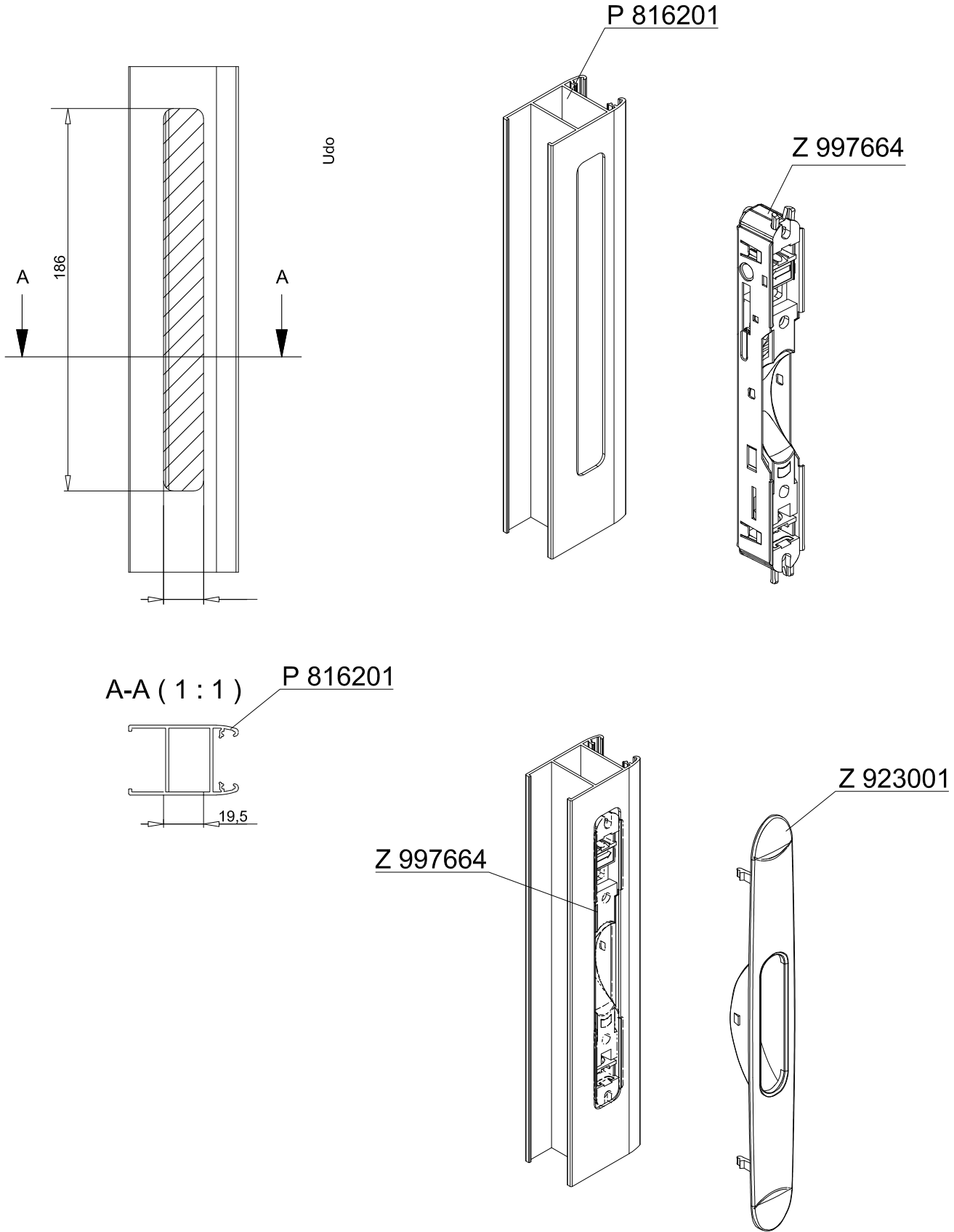

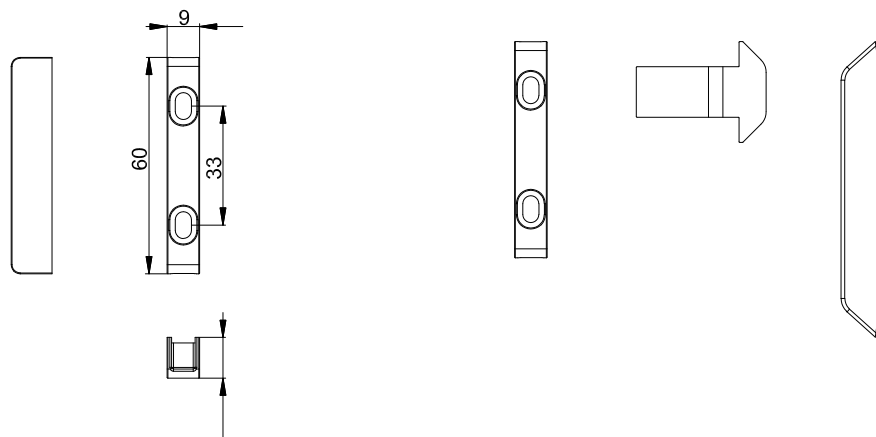
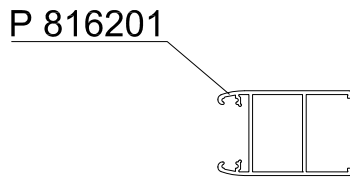
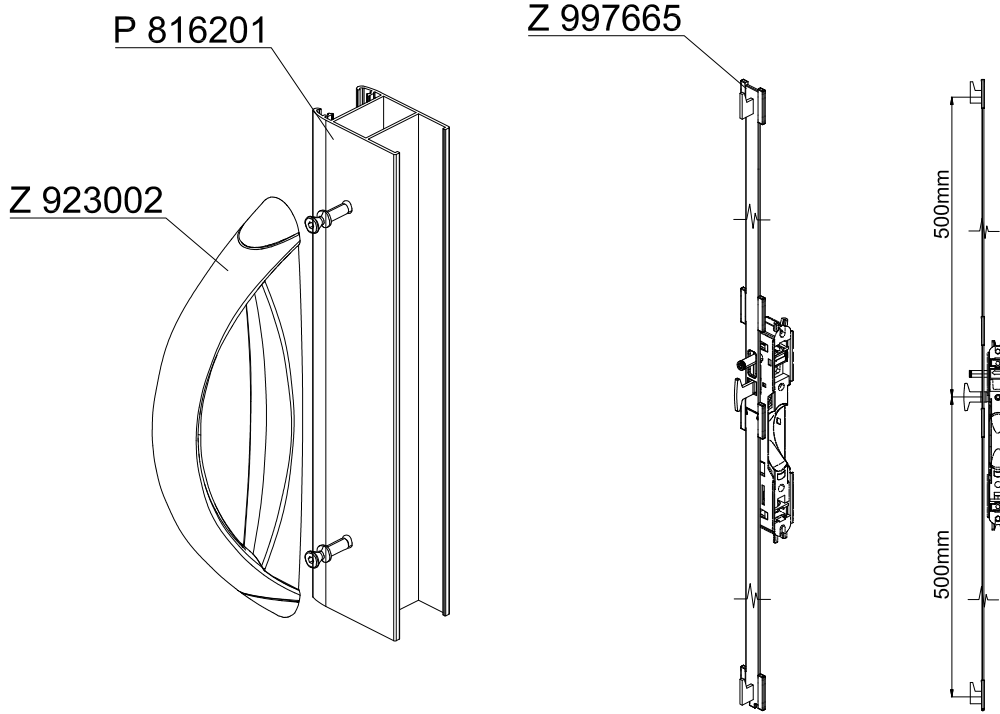

185002900

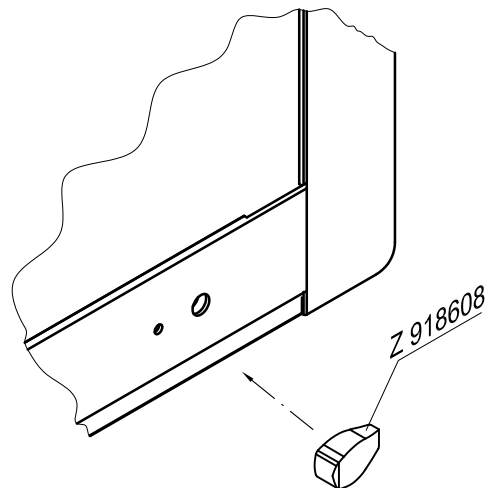
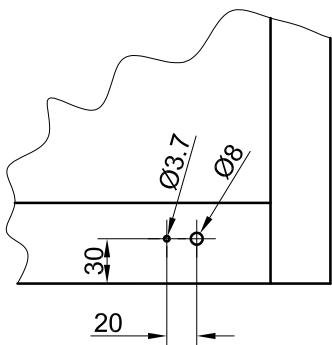
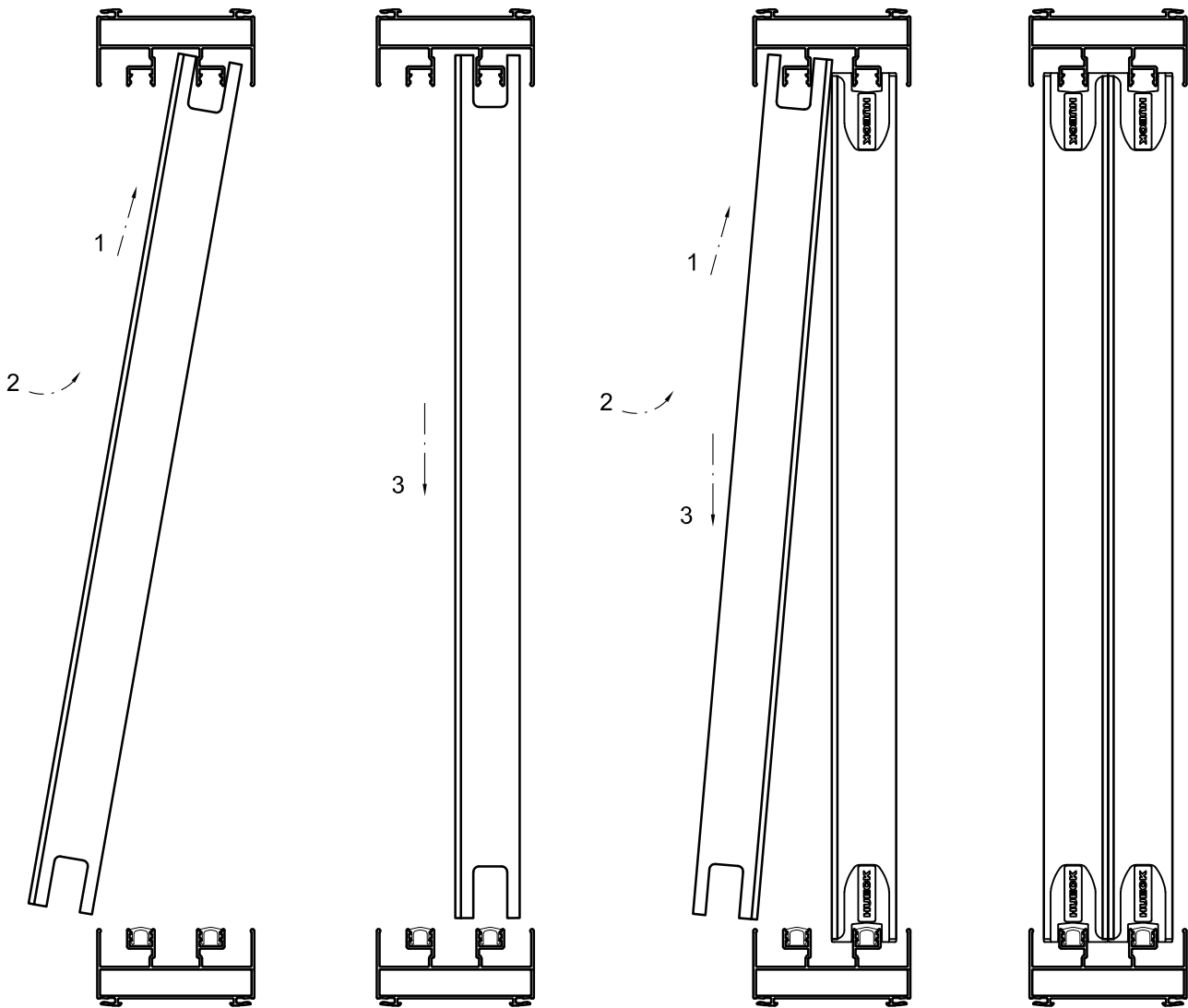

Fix the sash frame

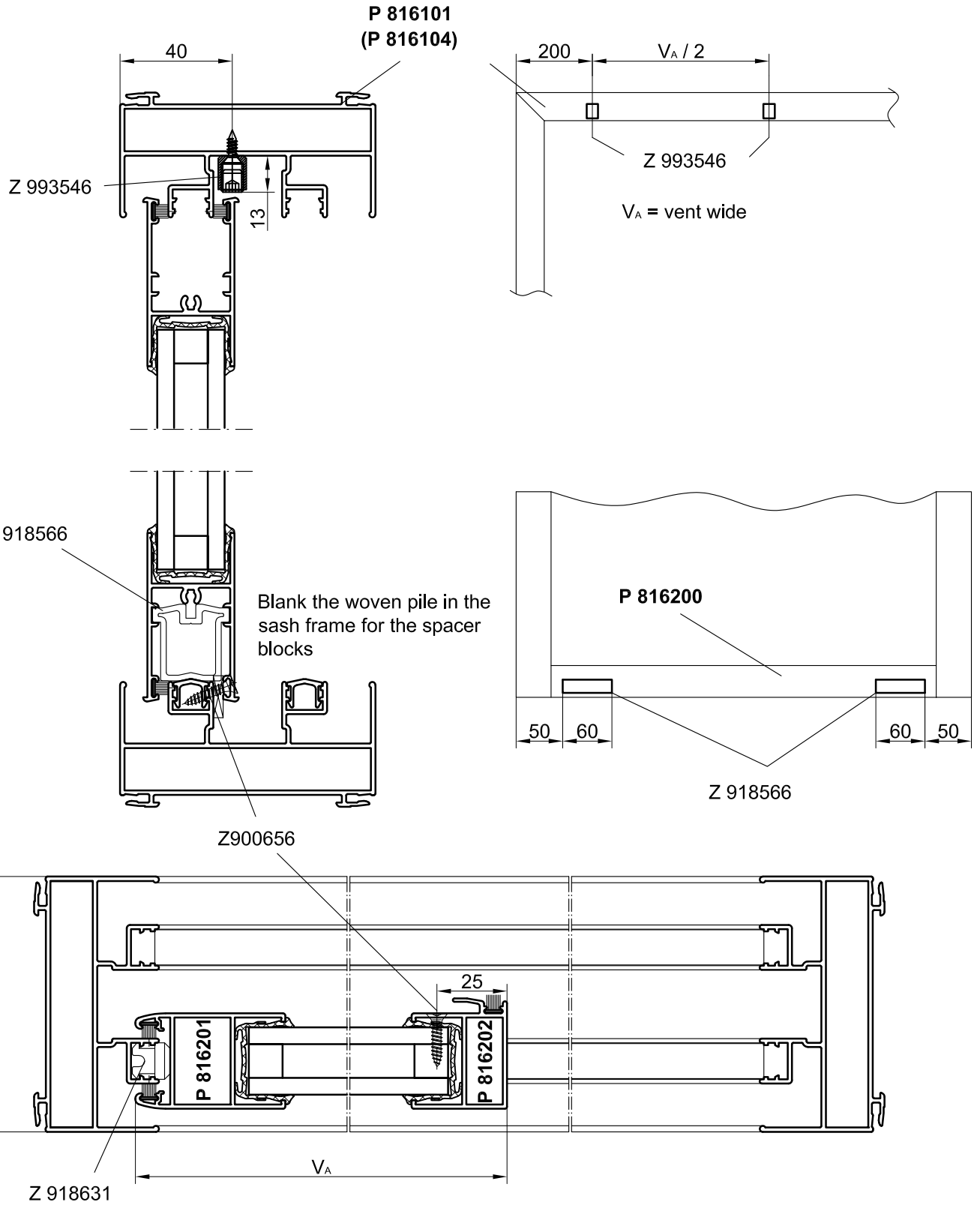

187003200

- 1) Cut the profile as cutting list
- 2) Place the pile (Z 918381) on the profile groove

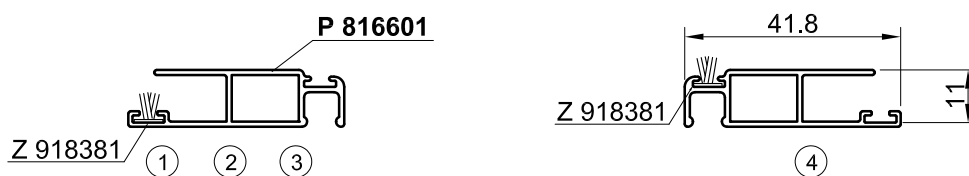
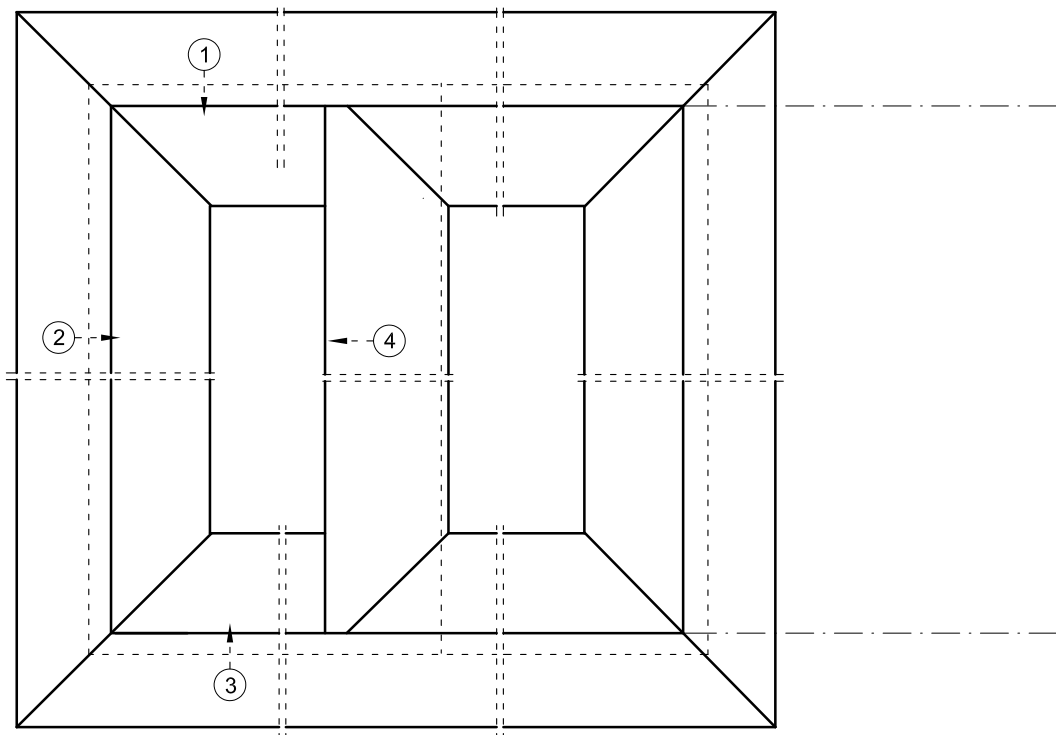

- 3) Please the Rollers following the position

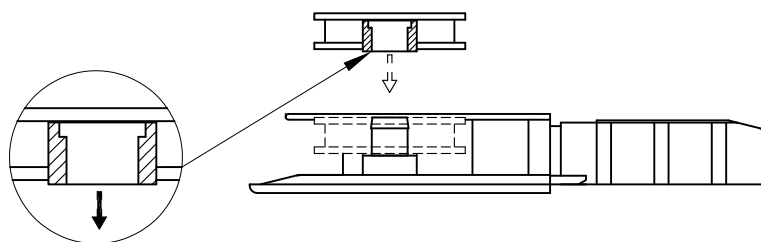

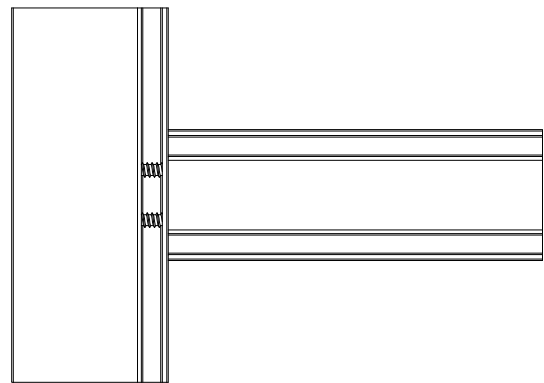
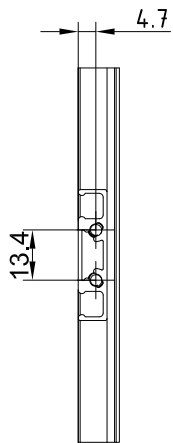
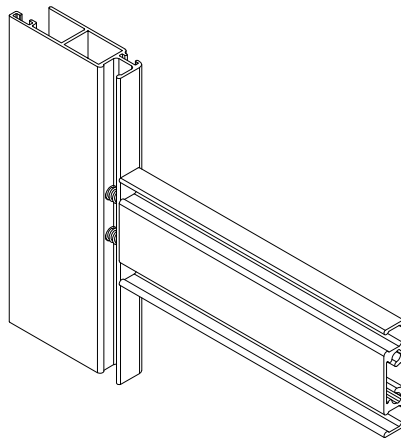
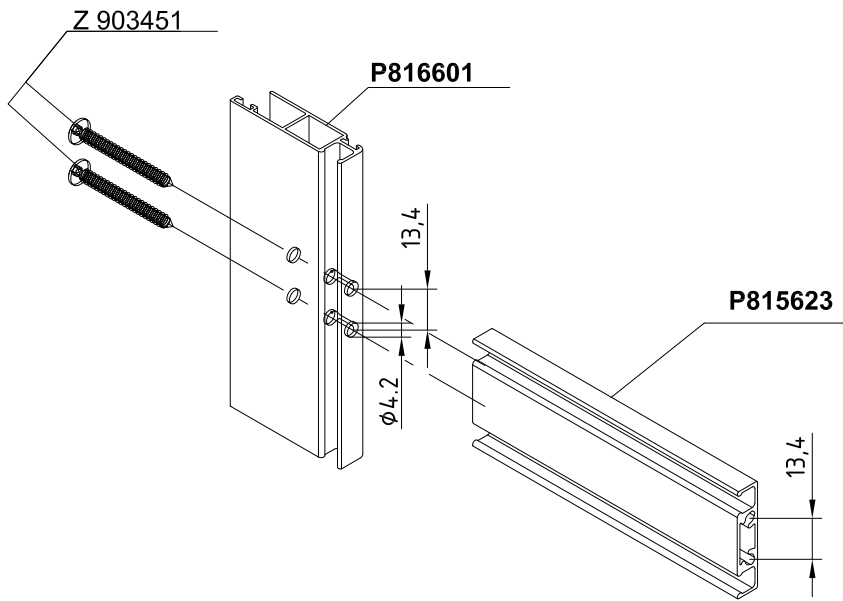

189003400

4) Insert the corner connector on the profile
(Place the connector with the rollers at the bottom).

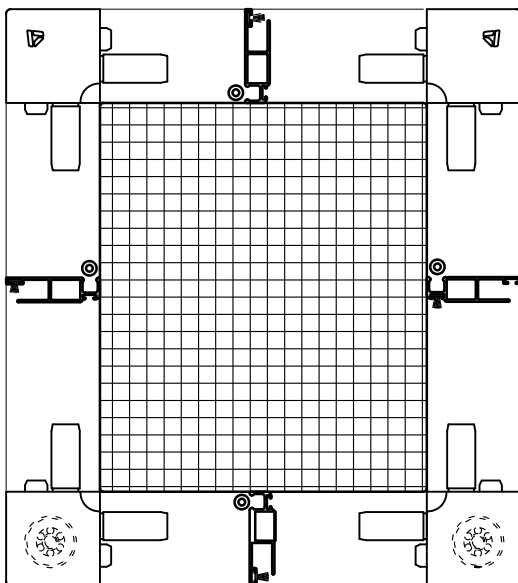

5) Place the mosquito net and fix it with the plastic tube. cut away the rest of the net.

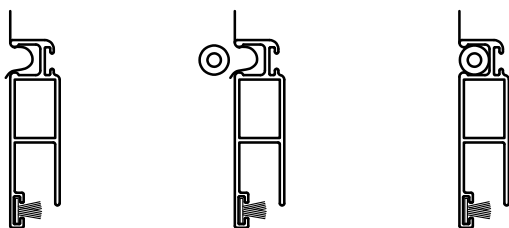

6) Install the fly screen in the element.

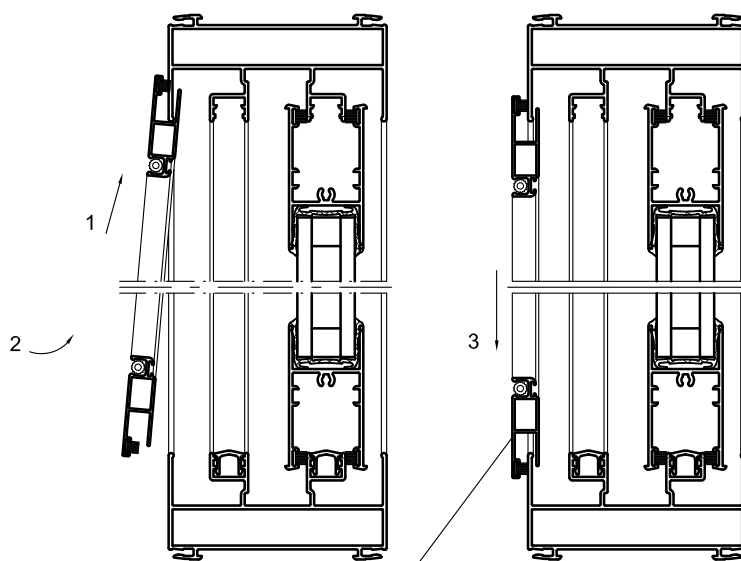

Ball roller and nylon track