

Trigon 50 NI



Trigon 60 NI



Trigon 50 SG NI



Trigon 60 SG NI

Curtain wall

Trigon - Facade systems

Contents - Trigon 50 / 60 (SG) NI

Page

Contents

2

Series Information

3 - 4

Trigon 50: Profile overview | Static profile value

11 - 16

Profiles | Connections

17 - 28

Trigon 60: Profile overview | Static profile value

31 - 36

Profiles | Connections

37 - 50

Glazing

61 - 72

Sections / Details

81 - 82

System-dependent accessories

101 - 110

Tools and auxiliary

141 - 142

Processing

151 - 176

Glas production SG

201 - 208

002000200

In addition to our catalogue Trigon 50 and 60 and Trigon 50-SG and 60-SG please mind the following advice:

Before the beginning of production, product training must take place through the company Eduard Hueck.

The same is applied for a training of the silicone supplier.

Primary the European approval ETA-09/0335 must be considered.

The contracted glass supplier must carry out the gluing job as per ETAG 002 or according to DIN-EN 13022.

The condition for this is that the workshop is supervised by itself or by third party.

For glasses with a coating on Pos.2 or Pos.3 an approval for a SG adhesion must be in hand for the coating. For coatings without corresponding approval, the glass edges in load bearing adhesive area must be uncoated or completely be freed mechanically of the coating. Please observe to this the following catalogue pages!

Product training for the glass supplier must take place through company Eduard Hueck. .

Please consider in terms of your order that the profiles are only in mill finish on stock and will be anodized for every order and that they are allowed to be used after positive adhesion tests. The anodized coating must not be older than 6 months.

Certainly this reference is valid also for our standard profiles of the insert elements such as Lambda 110 NI which are used for gluing. (While placing order, please refer without fail to the purpose of use)

The distance of glass supports Part No. Z 918577 is to be decided according to the requirement of static's.

It is obligatory that a proof of static's has to be performed for the load bearing adhesion and the max. glass dimensions.

Particular the shear expansion has to be calculated by your structural engineer for static's.

Eventually, the specific requirements of the country are specially to be observed.

Additional mechanical retainers are required on glazing according to TRAV.

Please observe to this the catalogue. It is required to mind the ETA-09/0335, ETAG 002, as well as DIN EN-13022 and DIN EN-1279.

In addition existing regional and international determinations can complement the specifications. (e.g. additional security cover plates for the outer pane as from an install height over 8m or similar) The producer is allowed to use only material and parts which are listed in the European Technical Approval or in our Trigon 50-SG and 60-SG catalogue.

Maintenance and cleaning

To maintain the attributes of the glass above the total specified period a professional cleaning adapted on the particular glazing is provided. During the annual general cleaning of the glass façade, a visual inspection should be carried out and, if applicable, defective sealing of the weather joint is to be repaired. In the course of these measures, the sealing at the glass edge bonding should be checked for damage. In this way, any mechanical and chemical damage to the silicone sealing and/or the load-bearing gluing can be recognized in due time so that consequential damage is prevented. Damage might be caused, for example, by exposure to:

- Acids, also acidic detergents such as sulphuric acid, nitric acid, acetic acid, etc.
- Other corrosive media affecting the substrate surface
- Mechanical detergents such as, for example, brushes or similar
- Bird damage
- Vandalism
- Imperfect planning such as, for example, dimensioning of the load-bearing gluing
- Imperfect execution such as, for example, lack of cleaning, primers and/or backfill

For cleaning the glass façade, only pH-neutral tensides (soaps) in a 1 % solution (maximum) are permitted in co-ordination with the glass industry and the manufacturer of the gluing system. In this way, normal dirt can be removed without causing damage to the silicone joint or the glass surface.

Applications of these detergents should not be used, neither should high-pressure cleaners, mechanical brushes or other abrasive tools or similar be employed. It is rather advisable to clean with the help of a soft cloth or sponge and plenty of liquid. Conventional tools such as chamois, rubber wiper or similar can be used for drying.

As a general rule, the maintenance and cleaning instructions issued by the glass and glue suppliers must be observed.

By usage self-cleaning glazing products of Dow Corning 757 or Sikasil WS-680 SC must be applied. Before this usage an agreement with the glass supplier and the silicone supplier regarding compatibility and interaction is required.

Smoothing agents shouldn't be abandoned. See also the information of the silicone suppliers.



003000300



Information on the series *	Design features standard glazing	<ul style="list-style-type: none"> • Design for vertical, curtain walls • Identical profile geometry for mullion and transom, mullion offcut can be used as transom • Straight cuts, no notching of transoms required • Ideal for floor and ceiling connection as mullion and transom are possible without offsetting • Optimised profile geometry with regard to weight and static parameters • Smoothed-off edges at the mullion and transom profile with a small radius of 0,8 mm and 2 mm • Various cover profiles
	Design features SG	<ul style="list-style-type: none"> • Structural glazing Design with 20 mm Silicon weather seal for vertical and inward inclined or polygonal curtain walls • European certification ETA 09/0335 • Maximum window size 2500 mm x 3500 mm • Easy installation of the glass units
	Modularsystem	<ul style="list-style-type: none"> • System components suitable for all the series: fittings, accessories, supplementary profiles, auxiliary accessories, tools
	Surfaces	<ul style="list-style-type: none"> • Anodisation in accordance with DIN 1761 • Plastic coating (wet paint, powder coating lacquer) in accordance with DIN 50939
	Connecting technology	<ul style="list-style-type: none"> • Mullion-transom connection approved by the building supervisory authority
	Elevation width	<ul style="list-style-type: none"> • Mullion-transom connection approved by the building supervisory authority
	Profile depth	<ul style="list-style-type: none"> • Transom and cover profiles with an elevation width of 50 mm in various profile geometries
	Insulating zone	<ul style="list-style-type: none"> • Spacer profiles made of glass fibre-reinforced polypropylene
	Glazing	<ul style="list-style-type: none"> • Glass thickness between 4 and 58 mm • External glazing with EPDM sealing profiles and screwed aluminium pressure plate profile • Internal sealing profiles optionally as vulcanised frames or as metre-length material • Continuous uniform gasket thickness on the room side
	Design features SG Gaskets	<ul style="list-style-type: none"> • Vulcanised shaped gasket pieces covering the entire joint area are used in the transom connection area • Optionally single-piece or two-piece EPDM gaskets as external gasket • Weather-independent, can be inserted on site without sealing material • EPDM spacer blocks to avoid crackling noise

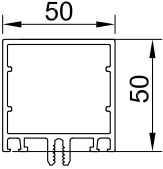
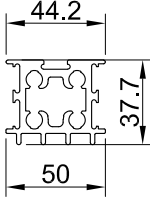
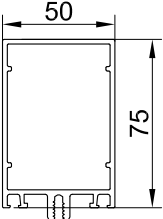
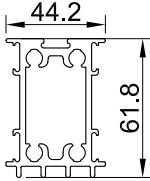
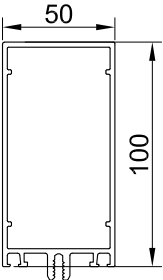
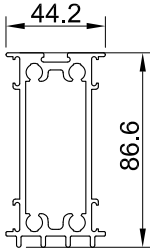
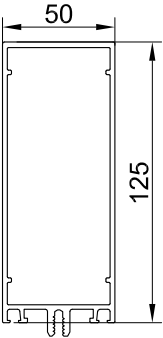
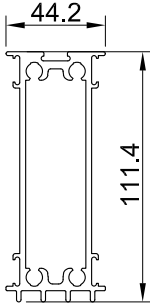
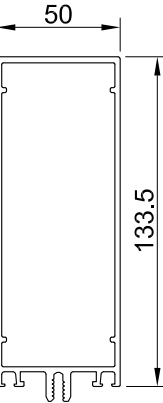
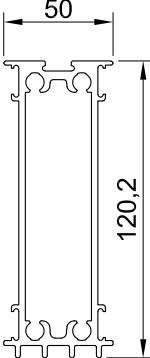

* All standards referred to herein, were valid at time of printing.
Valid test reports as well as technical information can be found in the download area of the site www.hueck.com

Profile overview and static profile values for Series Trigon 50



	Profile number	Horizontal axis		Vertical axis		External perimeter complete	Page -		Profile number	Horizontal axis		Vertical axis		External perimeter complete	Page -
		J_x (cm ⁴)	W_x (cm ³)	J_y (cm ⁴)	W_y (cm ³)					J_x (cm ⁴)	W_x (cm ³)	J_y (cm ⁴)	W_y (cm ³)		
	P 520248	19	7	17	7	332	17		P 599280	8	4	8	3	246	19
	P 520234	49	12	23	9	347	17		P 599357	33	10	11	5	304	19
	P 520235	102	18	29	12	397	17		P 599358	79	18	14	6	354	19
	P 520236	180	27	35	14	447	17		P 599359	150	26	17	8	404	19
	P 519353	211	29	37	15	464	17		P 599233	182	29	18	8	421	19

011000100

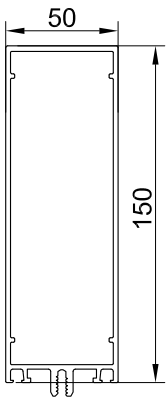
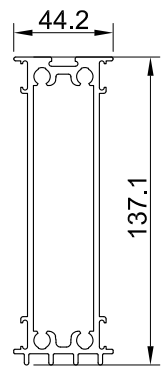
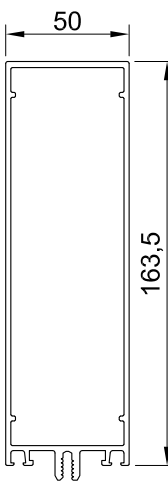
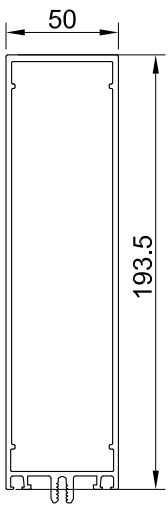
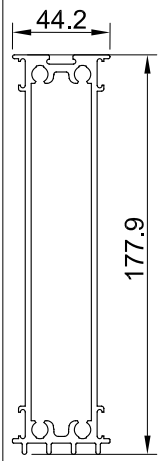
Profile overview and static profile values for Series Trigon 50

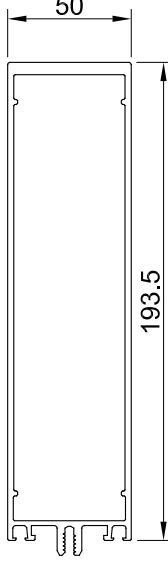
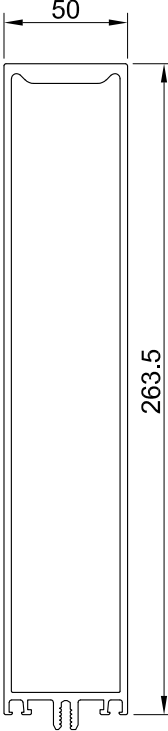
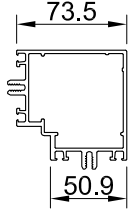

	Profile number	Horizontal axis		Vertical axis		External perimeter complete	Page -		Profile number	Horizontal axis		Vertical axis		External perimeter complete	Page -
		J_x (cm ⁴)	W_x (cm ³)	J_y (cm ⁴)	W_y (cm ³)					J_x (cm ⁴)	W_x (cm ³)	J_y (cm ⁴)	W_y (cm ³)		
	P 519358	282	35	41	17	497	17		P 599279	255	36	19	8	455	19
	P 519354	350	40	45	18	524	17								
	P 519356	590	59	59	24	584	17		P 599238	496	55	24	11	533	19

Profile overview and static profile values for Series Trigon 50



	Profile number	Horizontal axis		Vertical axis		External perimeter complete	Page -		Profile number	Horizontal axis		Vertical axis		External perimeter complete	Page -
		J_x (cm ⁴)	W_x (cm ³)	J_y (cm ⁴)	W_y (cm ³)					J_x (cm ⁴)	W_x (cm ³)	J_y (cm ⁴)	W_y (cm ³)		
	P 520229	670	63	61	24	584	17								
	P 519359	1787	124	94	37	724	17								
	P 520190	61	61	15	15	489	18								

013000300

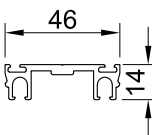
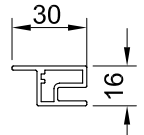
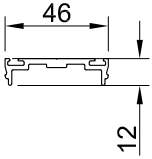
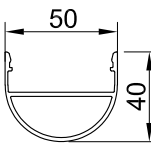
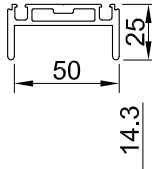
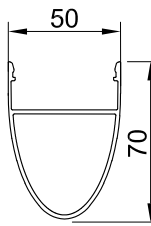
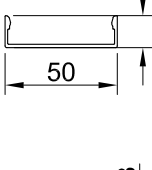
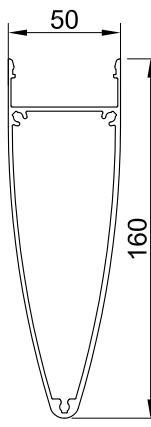
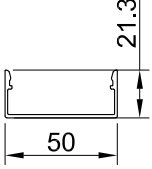
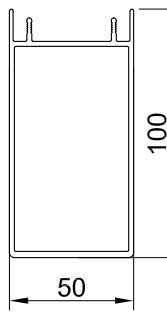
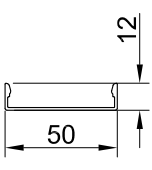
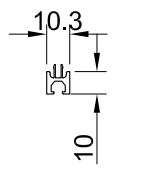
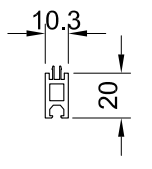
Profile overview and static profile values for Series Trigon 50

	Profile number	Horizontal axis		Vertical axis		External perimeter complete	Page		Profile number	Horizontal axis		Vertical axis		External perimeter complete	Page
		J_x (cm ⁴)	W_x (cm ³)	J_y (cm ⁴)	W_y (cm ³)					J_x (cm ⁴)	W_x (cm ³)	J_y (cm ⁴)	W_y (cm ³)		
	P 419430	-	-	-	-	206	20		P 520259	-	-	-	-	105	20
	P 419438	-	-	-	-	158	20		P 520237	-	-	-	-	199	21
	P 519433	-	-	-	-	213	20		P 520238	-	-	-	-	258	21
	P 419605	-	-	-	-	155	20		P 520239	-	-	-	-	429	21
	P 419606	-	-	-	-	187	20		P 551056	-	-	-	-	365	21
	P 419609	-	-	-	-	146	20								
	P 419900	-	-	-	-	82	20								
	P 519901	-	-	-	-	104	20								

Profile overview and static profile values for Series Trigon 50

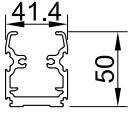
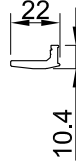
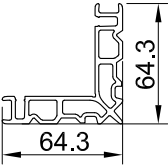
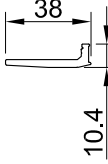
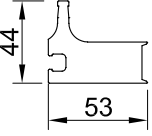
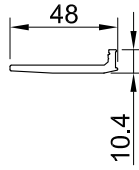
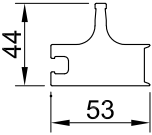
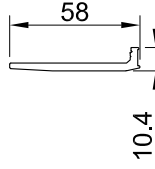
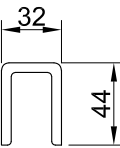
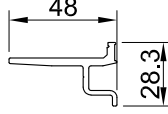
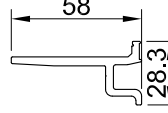
	Profile number	Horizontal axis		Vertical axis		External perimeter complete	Page -		Profile number	Horizontal axis		Vertical axis		External perimeter complete	Page -
		J_x (cm ⁴)	W_x (cm ³)	J_y (cm ⁴)	W_y (cm ³)					J_x (cm ⁴)	W_x (cm ³)	J_y (cm ⁴)	W_y (cm ³)		
	P 499613	-	-	-	-	378	22		P 499569	-	-	-	-	62	25
	P 599343	-	-	-	-	350	27		P 499561	-	-	-	-	94	25
	P 499758	-	-	-	-	105	26		P 499571	-	-	-	-	114	25
	P 499759	-	-	-	-	105	26		P 499586	-	-	-	-	134	25
	P 499760	-	-	-	-	56	26		P 499609	-	-	-	-	170	25
									P 499612	-	-	-	-	190	25

015000600

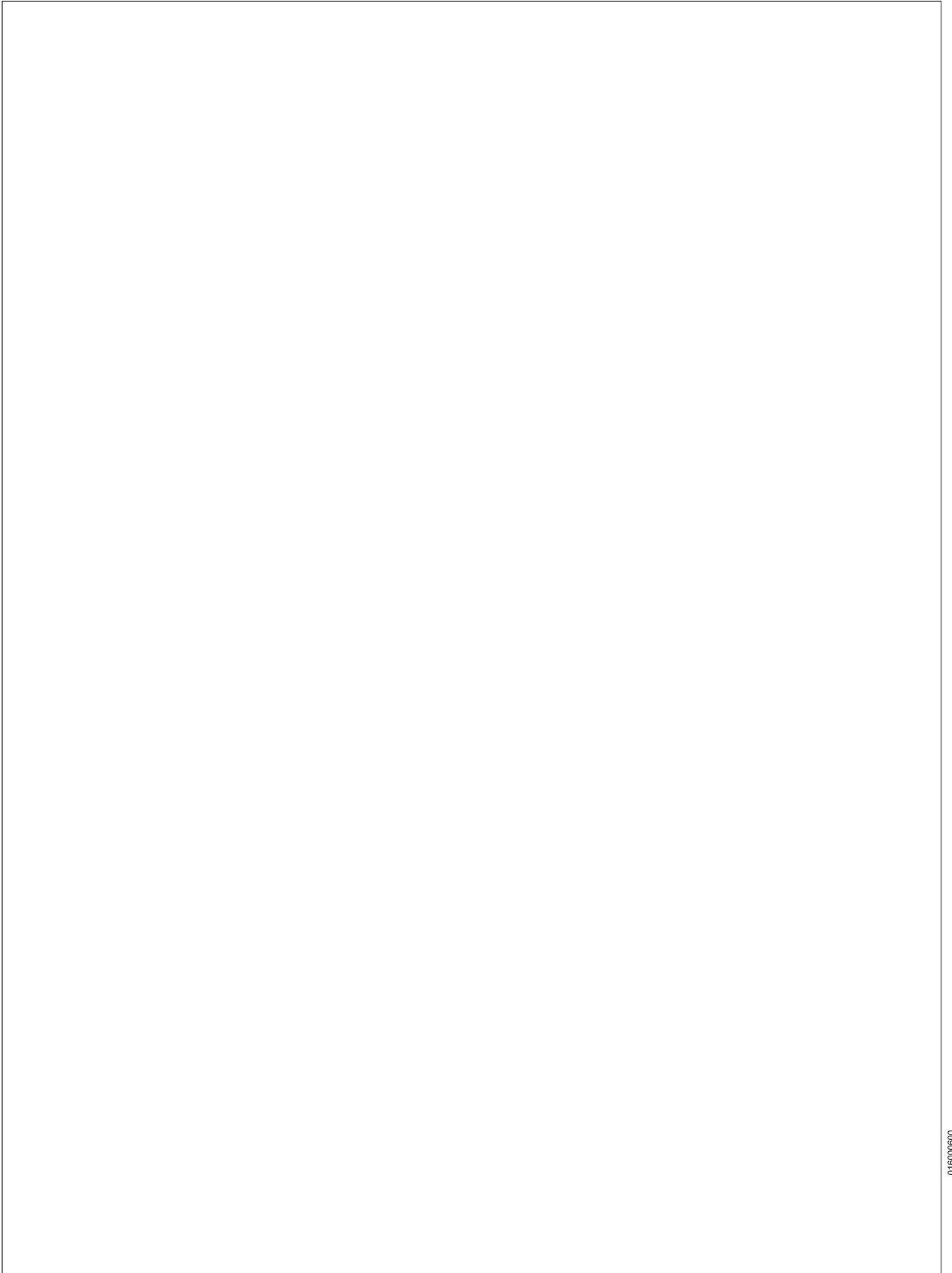

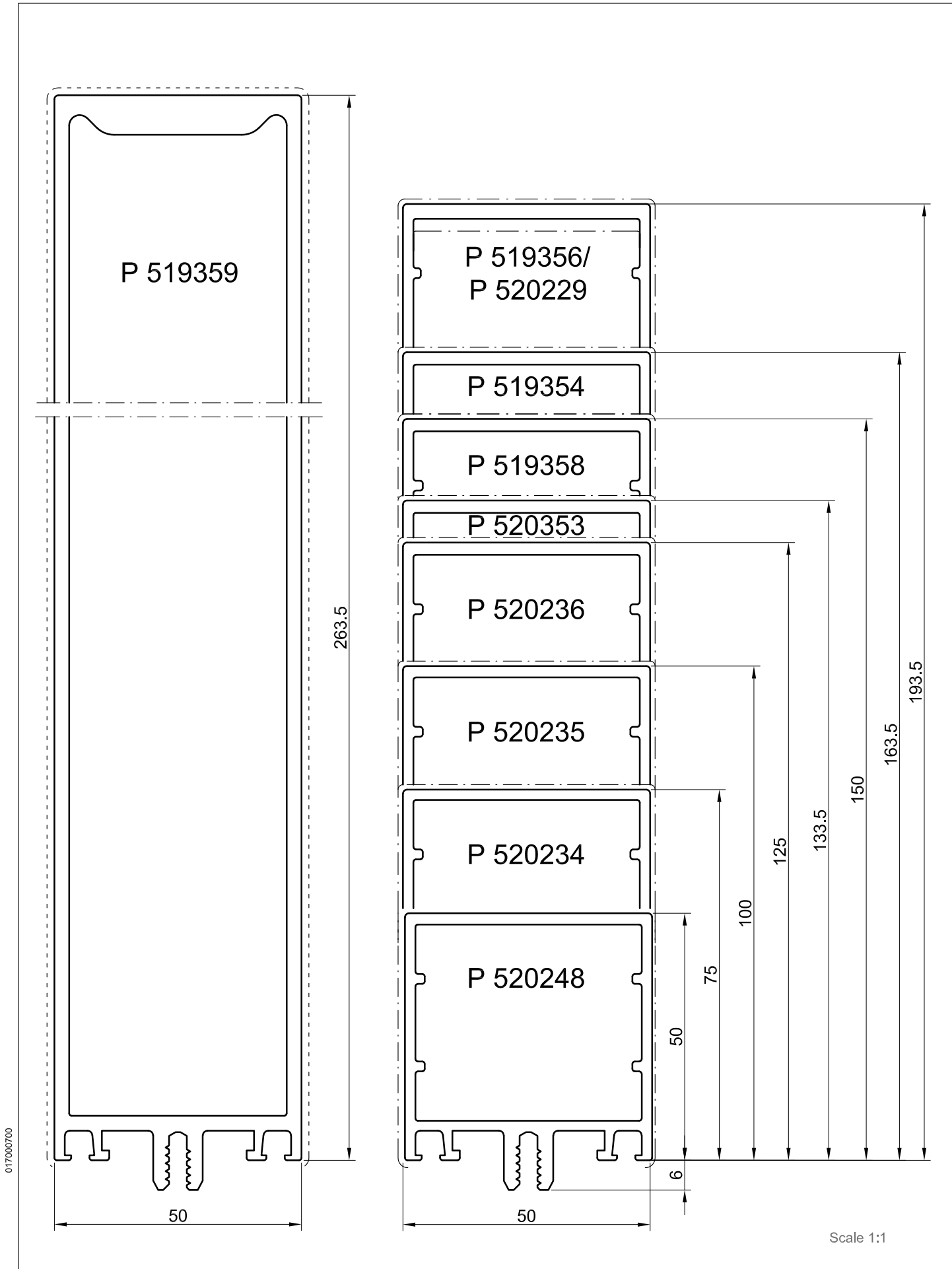

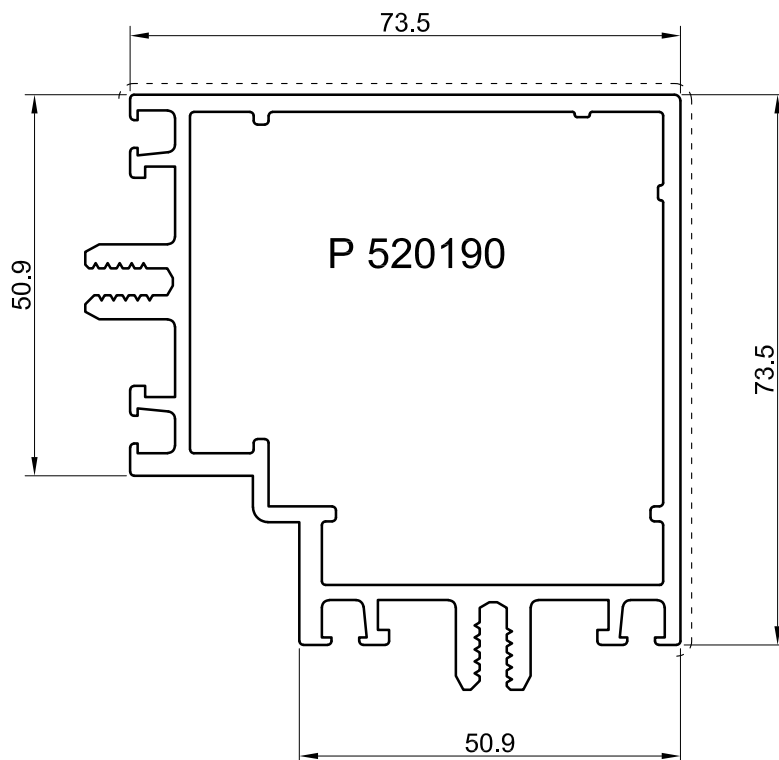

Scale 1:1

018000800

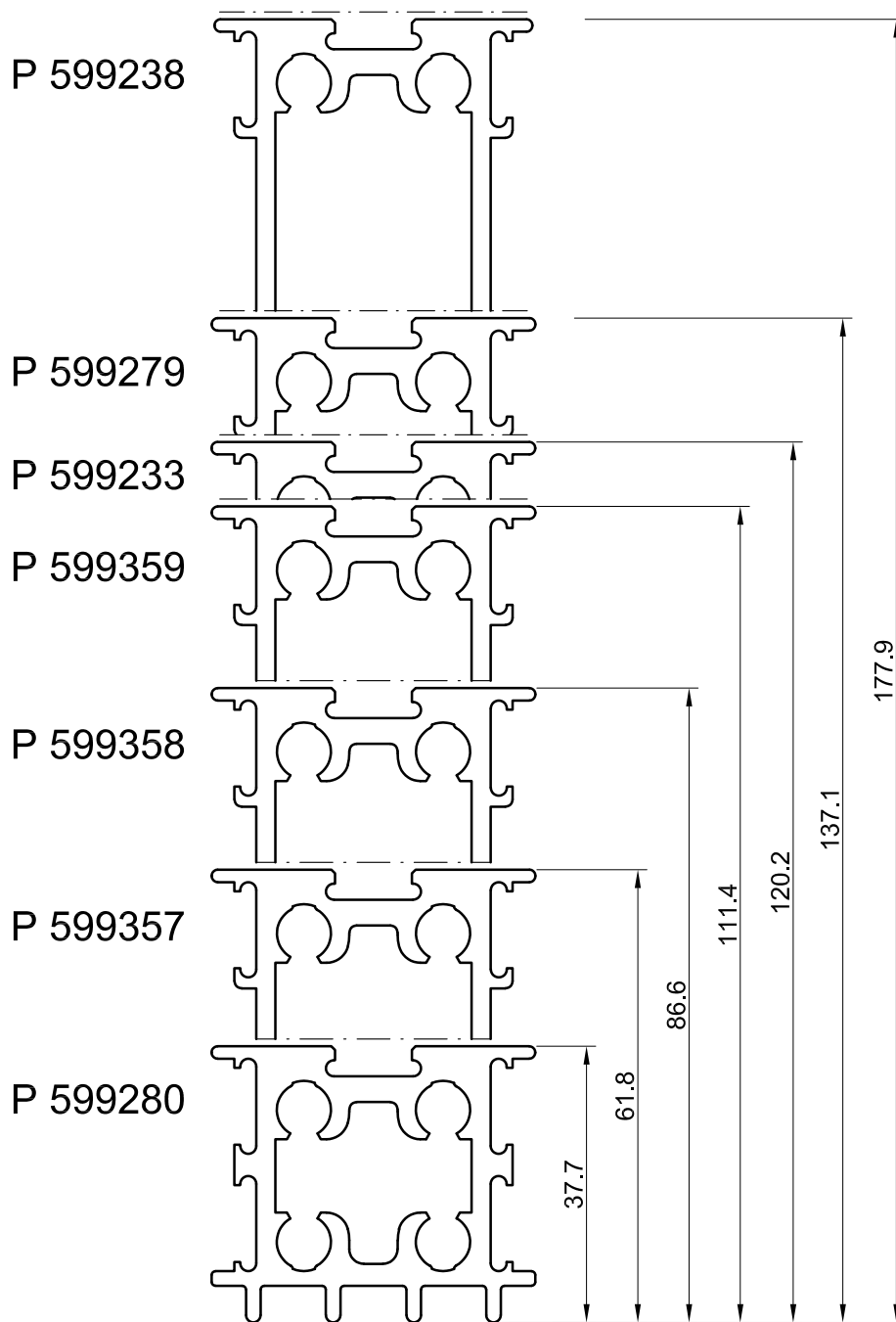

019000900

Scale 1:1

Pressure plate profiles for single gasket

Snap-in cover profiles for P 419438

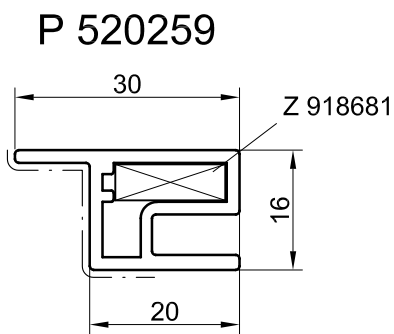
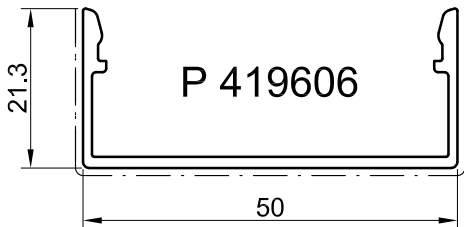
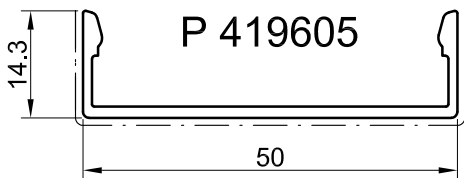
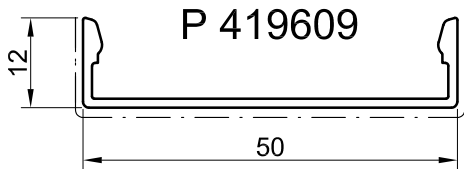

P 419430

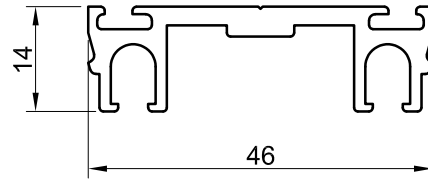

P 419438

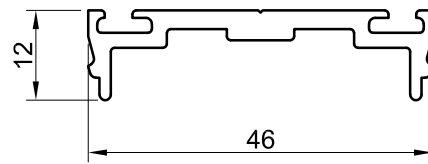

P 519433

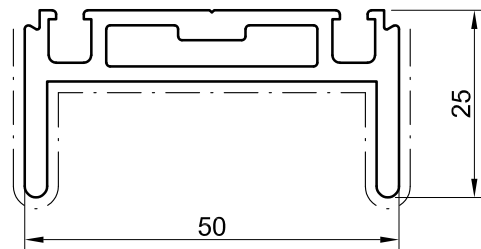

Supplementary profiles

P 419900

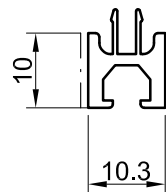

P 519901

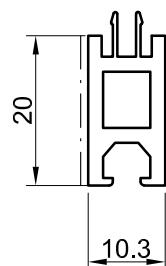

Scale 1:1

P 520238

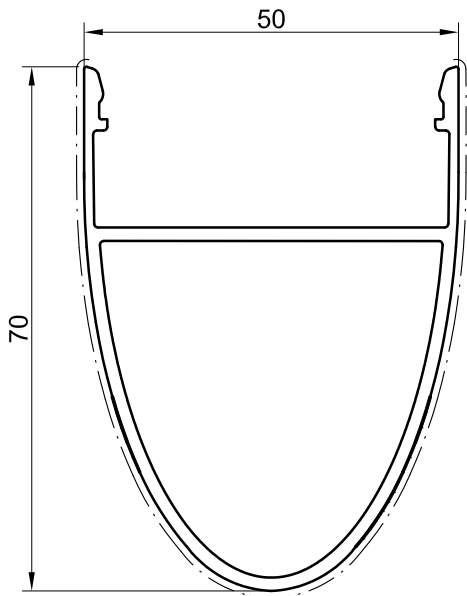

P 520237

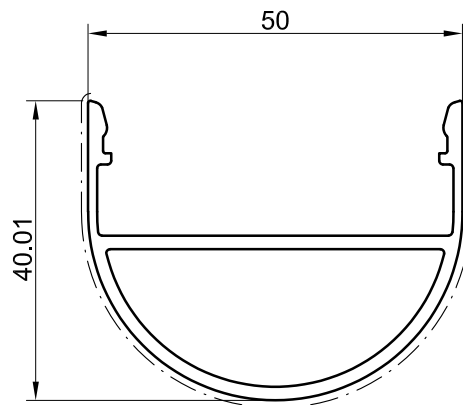

P 520239

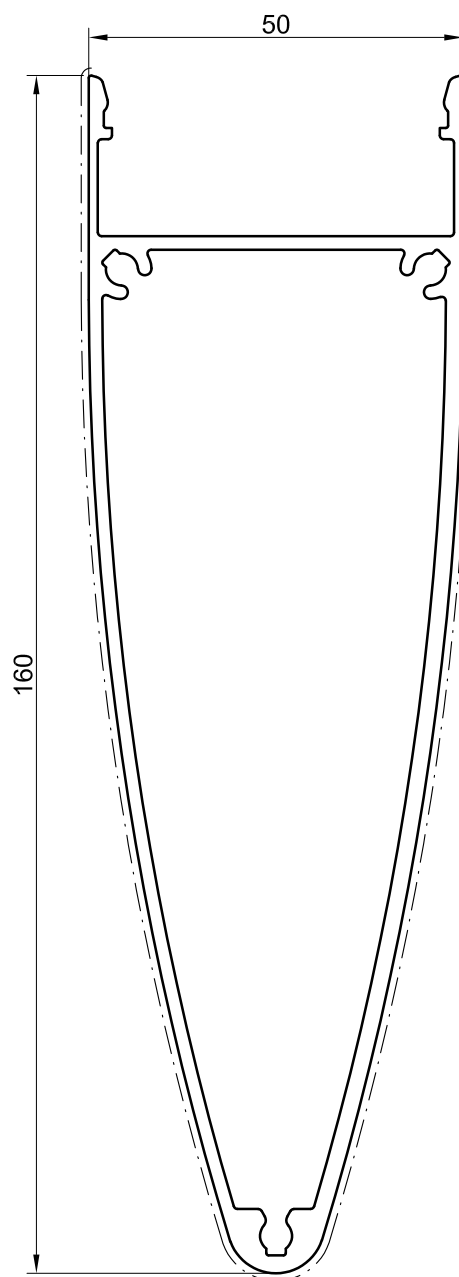

P 551056

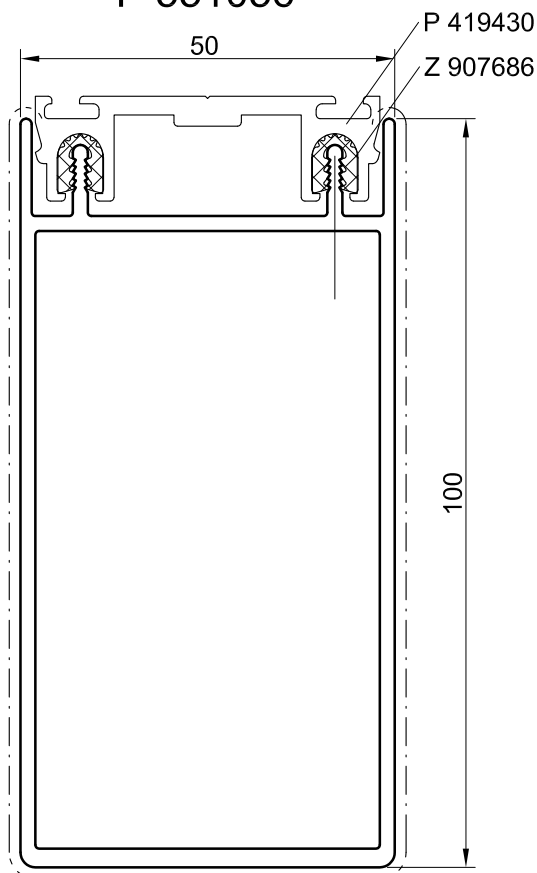

Scale 1:1

P 499613

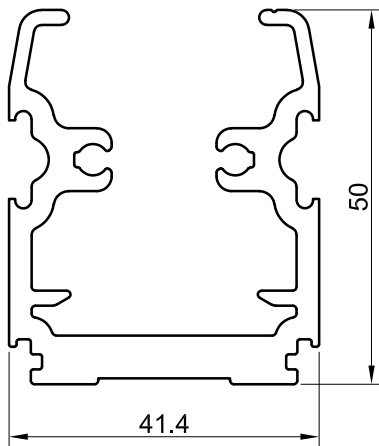

article no.:	profile no.:	length	pin
Z918574	P499613	38,6 mm	1 x 912865
Z918575	P499613	62,5 mm	2 x 912865

Z 918574

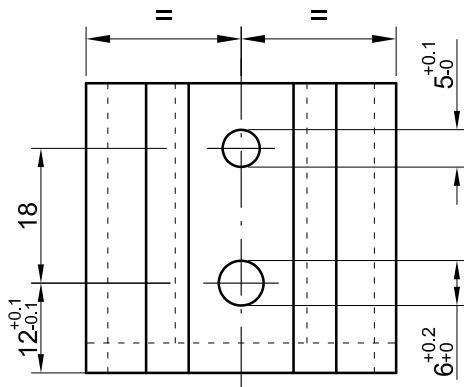

Z 912865

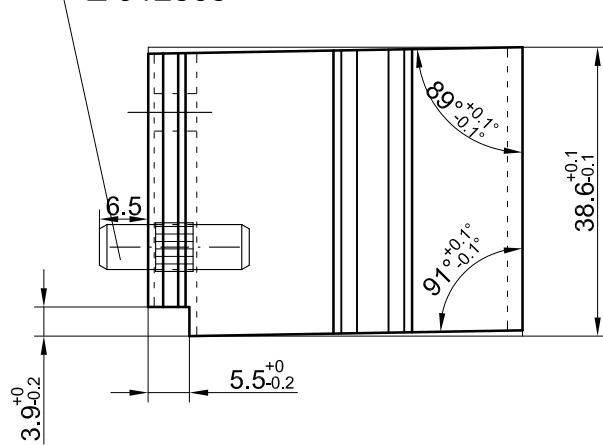

Z918575

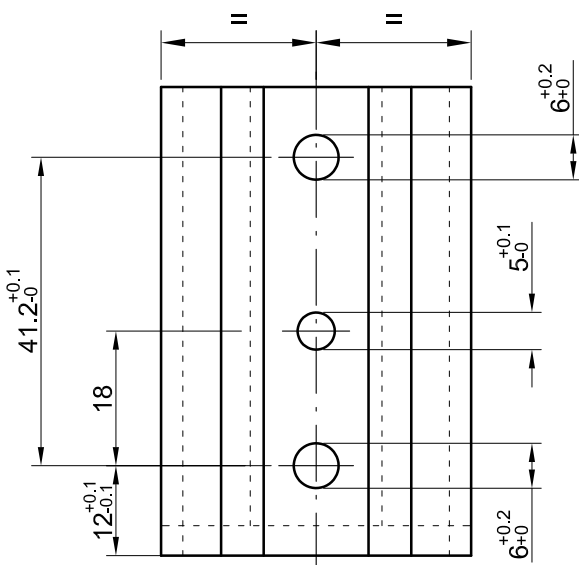

Z 912865

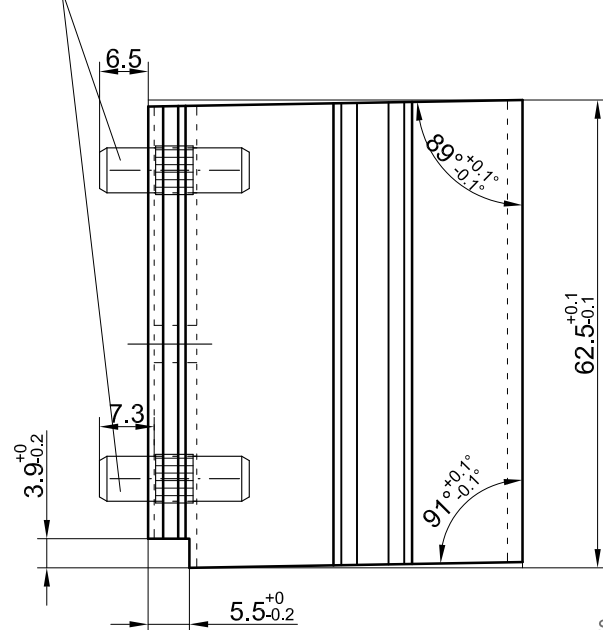

Scale 1:1

P 499613

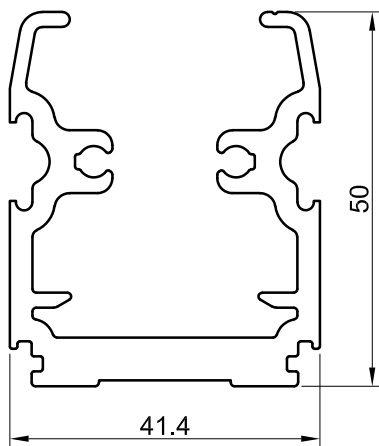

article no.:	profile no.:	length (X)	length (Y)	pin
Z918579	P499613	89,0 mm	68,0 mm	2 x 912865
Z918580	P499613	111,8 mm	68,0 mm	2 x 912865

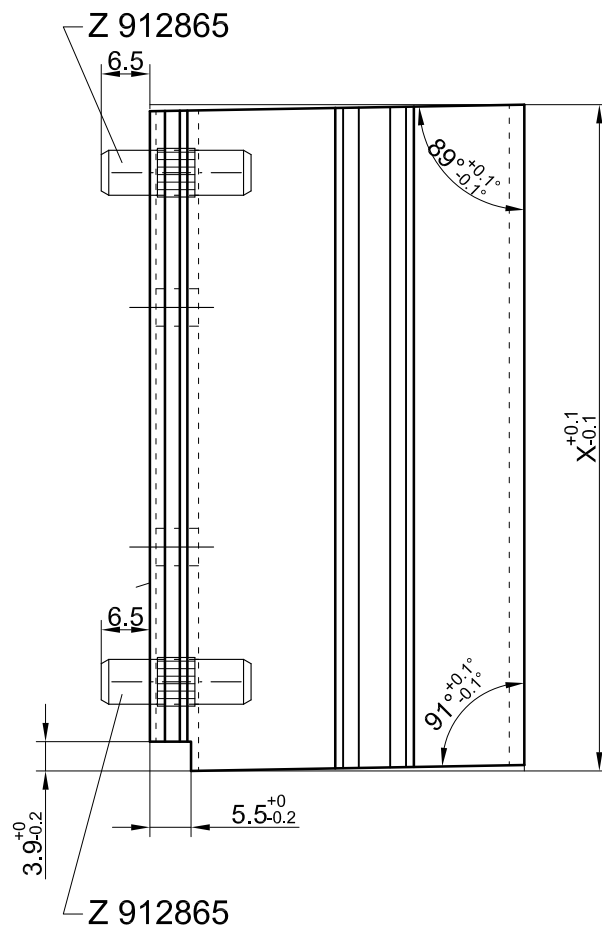
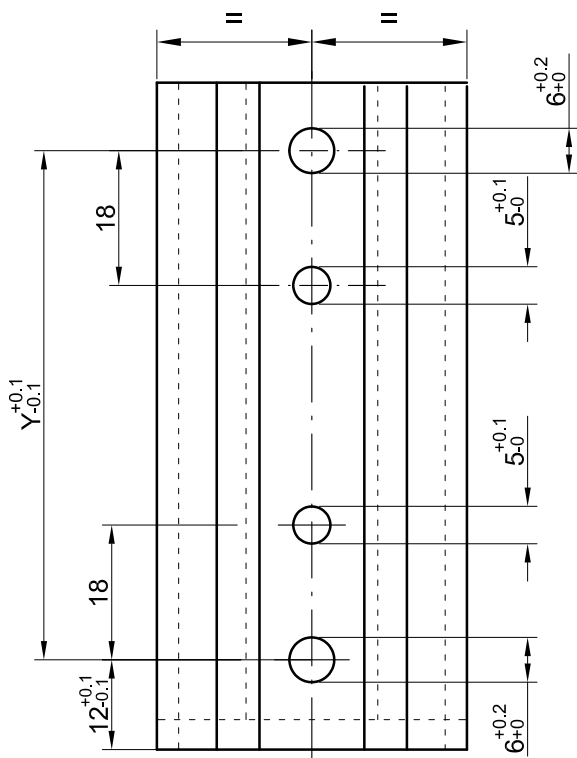

023001300

Scale 1:1

P 499613

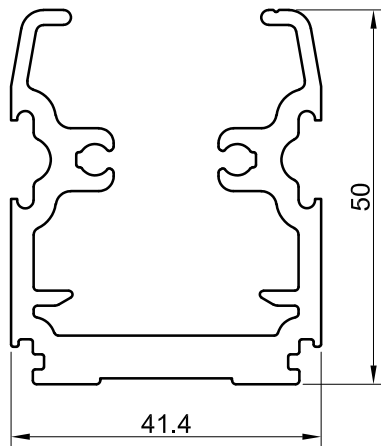

article no.:	profile no.:	length (X)	length (Y)	pin
Z918963	P499613	122,0 mm	101,0 mm	2 x 912865
Z918581	P499613	138,3 mm	101,0 mm	2 x 912865
Z918964	P499613	152,0 mm	101,0 mm	2 x 912865
Z918661	P499613	179,5 mm	130,8 mm	2 x 912865

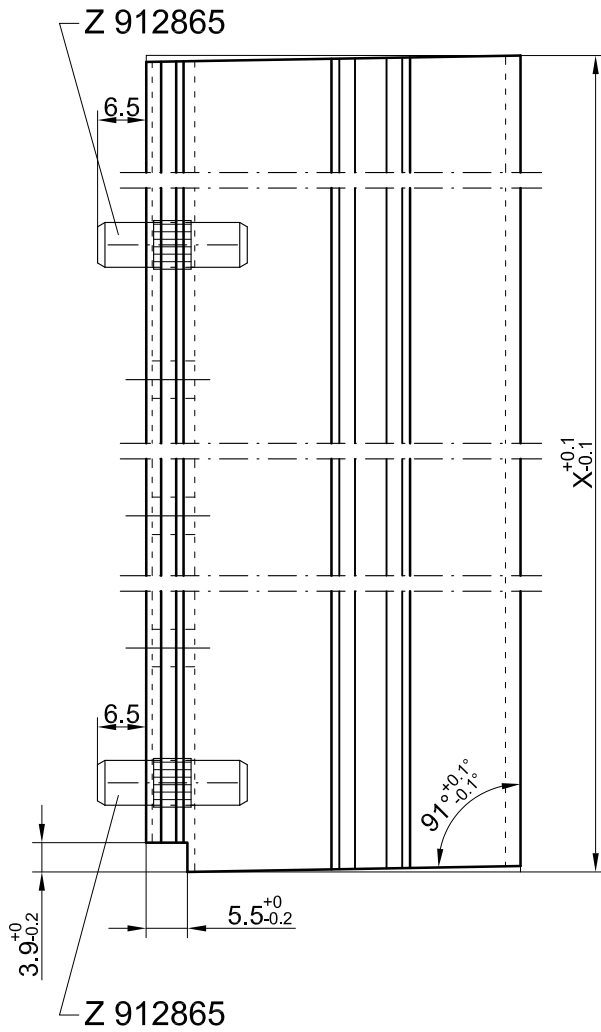
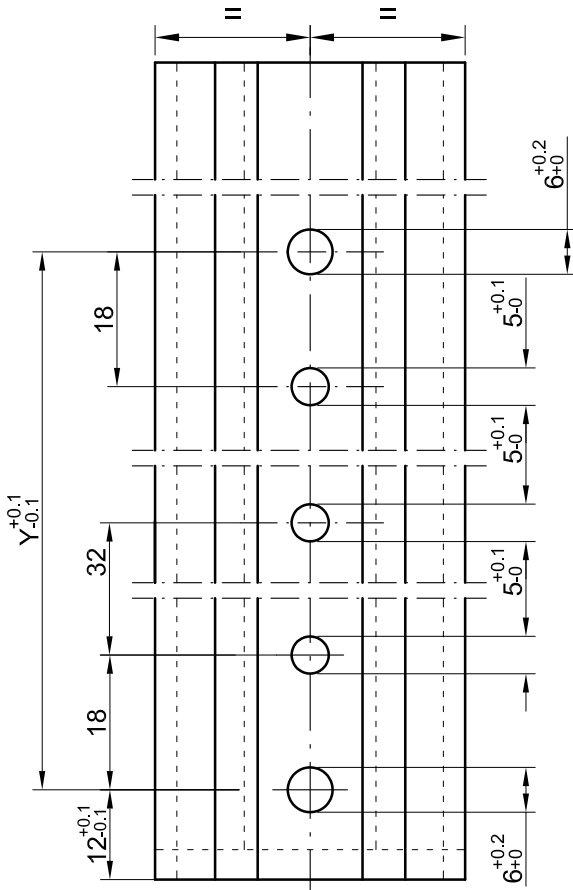

024001400

Scale 1:1

P 499569

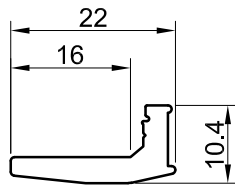

article no.:	profile no.:	length
Z911809	P499569	100 mm

P 499561

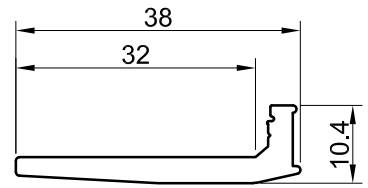

article no.:	profile no.:	length
Z911810	P499561	100 mm

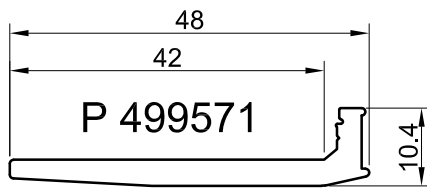

article no.:	profile no.:	length
Z911811	P499571	100 mm

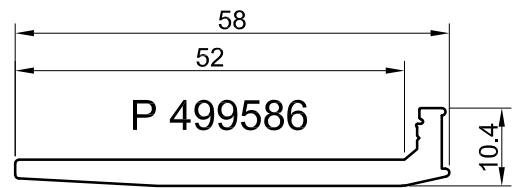

article no.:	profile no.:	length
Z911898	P499586	100 mm

article no.:	profile no.:	length (X)	length (Y)	pad
Z997468	P499586	8 mm	50,0 mm	Z918560
Z997462	P499586	6 mm	52,0 mm	Z918560

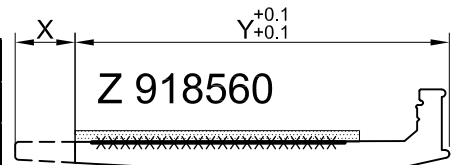

P 499586

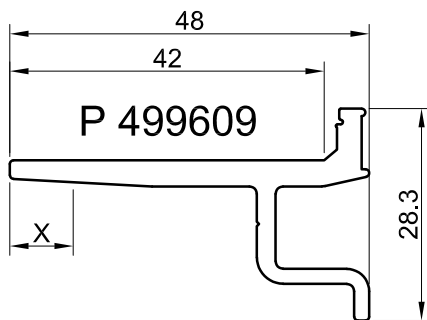

article no.:	profile no.:	length	length (x)
Z912727	P499609	100 mm	x=10
Z912728	P499609	100 mm	x=0

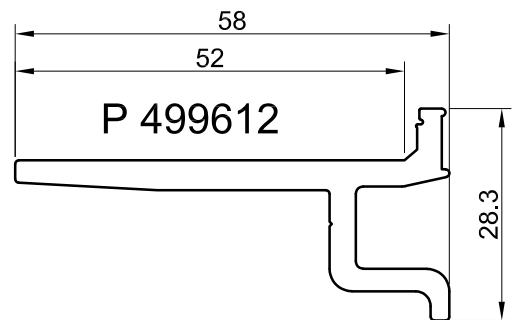

article no.:	profile no.:	length
Z912729	P499612	100 mm

025001500

Scale 1:1

P 499758

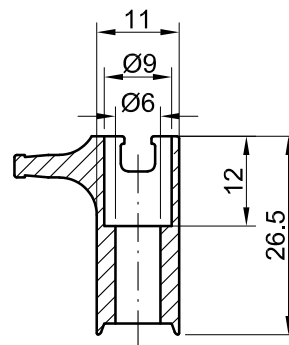
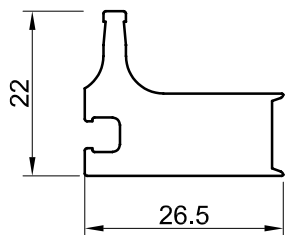

article no.:	profile no.:	length	gasket	screw
Z918577	P499758	35 mm	Z918588	2 x 911944

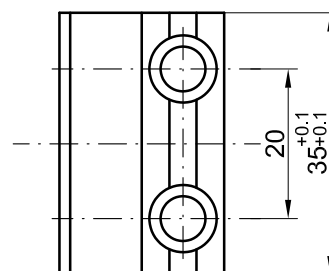

P 499759

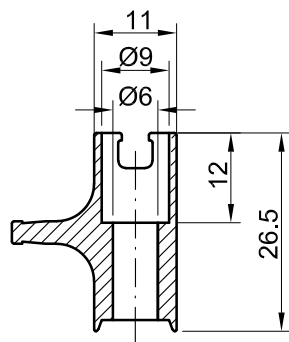
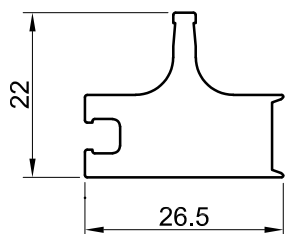

article no.:	profile no.:	length	gasket	screw
Z918576	P499759	35 mm	Z918588	2 x 911944

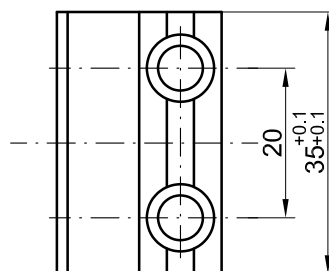

P 499760

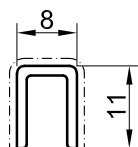

Scale 1:1

P 599343

article no.:	profile no.:	length
Z918681	P599343	4,8 mm

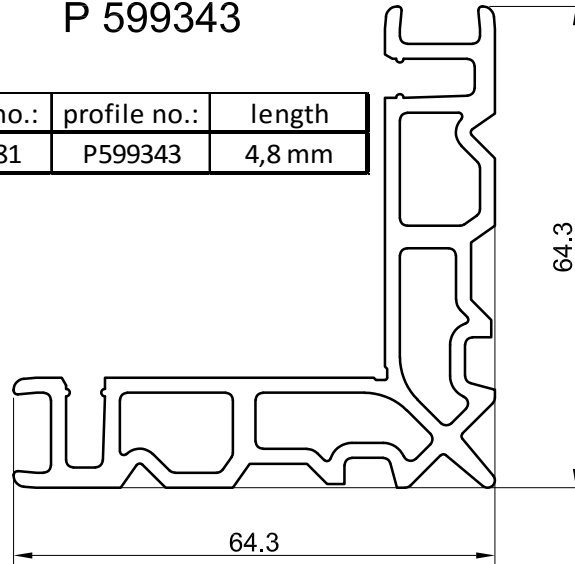

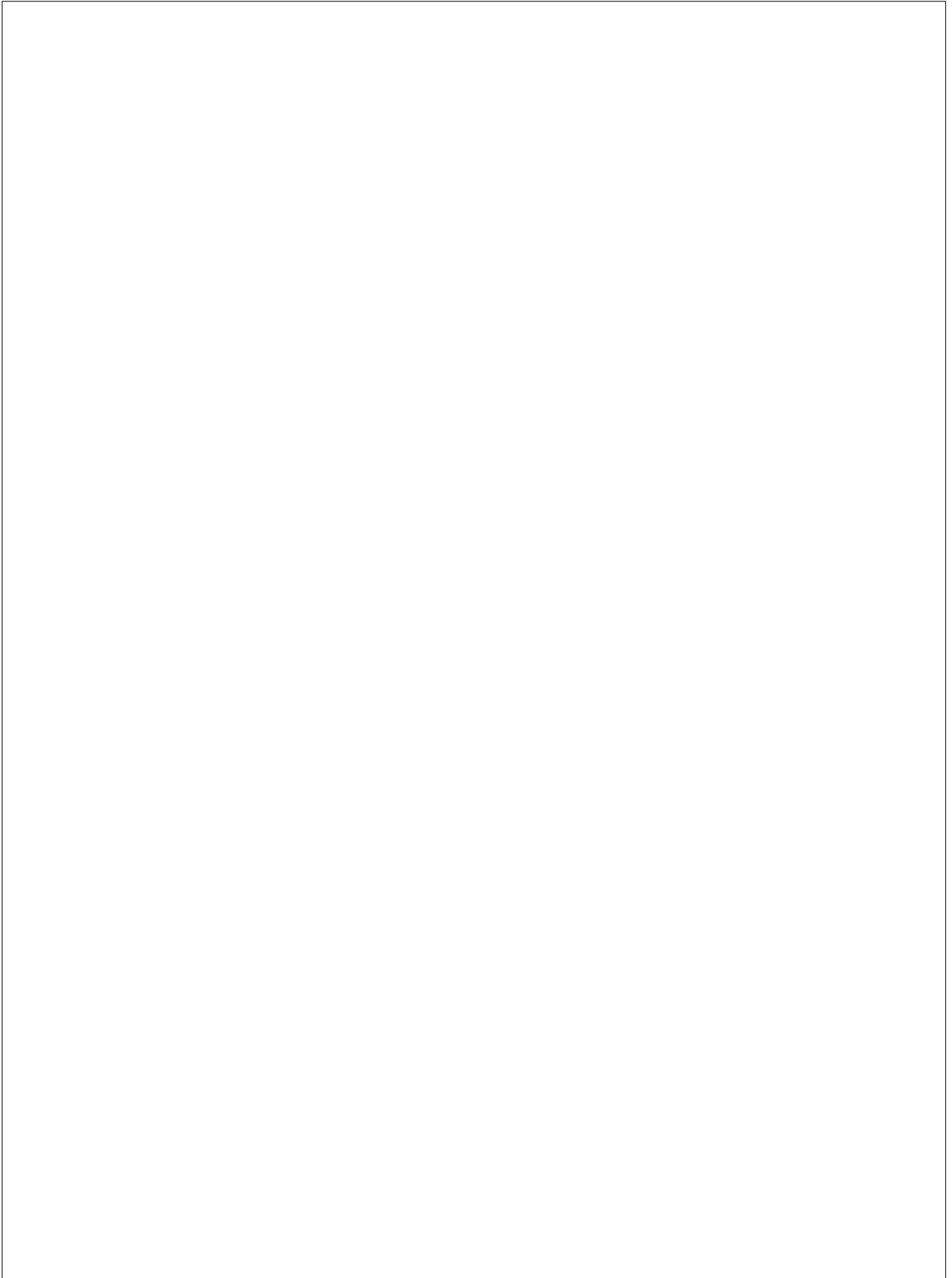

027001700

Scale 1:1



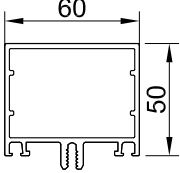
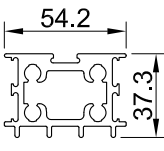
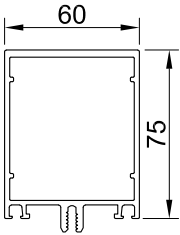
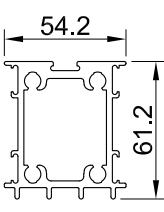
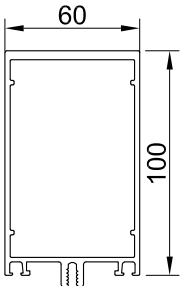
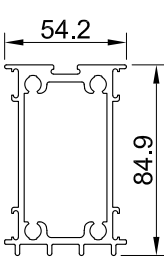
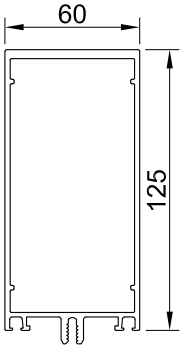
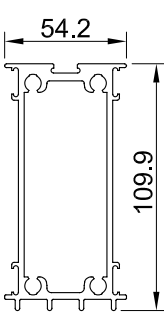
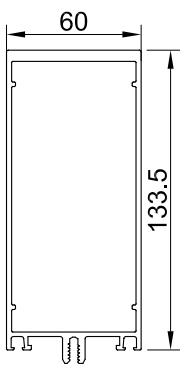
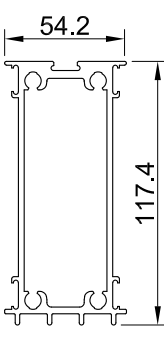

Profile overview and static profile values for Series Trigon 60



	Profile number	Horizontal axis		Vertical axis		External perimeter complete	Page -		Profile number	Horizontal axis		Vertical axis		External perimeter complete	Page -
		J_x (cm ⁴)	W_x (cm ³)	J_y (cm ⁴)	W_y (cm ³)					J_x (cm ⁴)	W_x (cm ³)	J_y (cm ⁴)	W_y (cm ³)		
	P 524164	21	7	27	9	317	37		P 599360	10	5	16	6	265	40
	P 524113	68	15	38	13	367	37		P 599261	38	11	21	8	323	40
	P 524114	136	24	49	16	417	37		P 599302	89	19	26	10	371	40
	P 524115	232	33	59	20	467	37		P 599303	171	29	31	12	421	40
	P 524122	291	63	38	21	484	37		P 599309	201	33	32	12	436	40

031000100

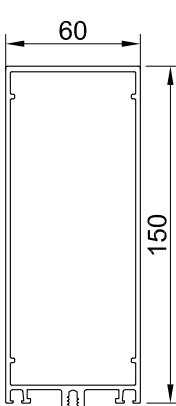
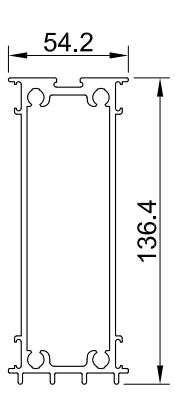
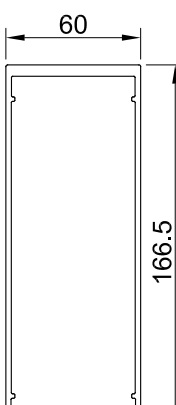
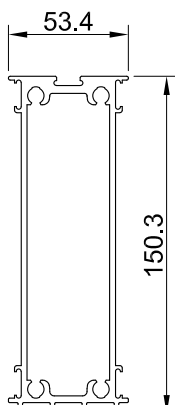
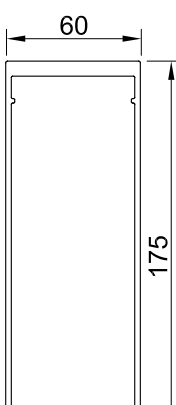
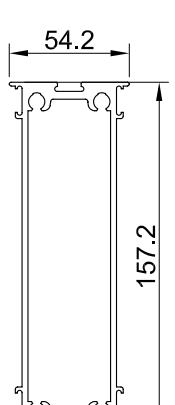
Profile overview and static profile values for Series Trigon 60

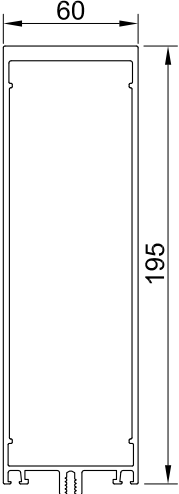
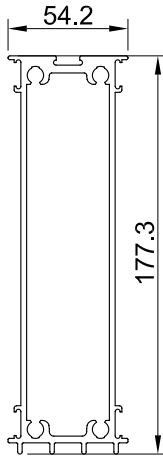
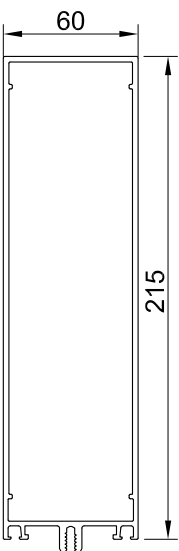
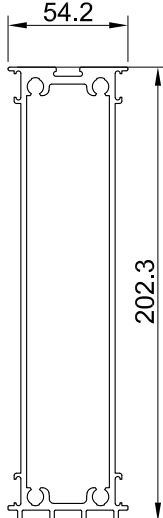

	Profile number	Horizontal axis		Vertical axis		External perimeter complete	Page		Profile number	Horizontal axis		Vertical axis		External perimeter complete	Page
		J_x (cm ⁴)	W_x (cm ³)	J_y (cm ⁴)	W_y (cm ³)					J_x (cm ⁴)	W_x (cm ³)	J_y (cm ⁴)	W_y (cm ³)		
	P 524165	306	38	62	21	517	37		P 599361	292	40	36	14	470	40
	P 524123	503	78	53	26	550	37		P 599310	372	39	47	14	498	41
	P 524117	619	60	86	29	567	37		P 599305	417	50	41	15	512	40

Profile overview and static profile values for Series Trigon 60



	Profile number	Horizontal axis		Vertical axis		External perimeter complete	Page	-		Profile number	Horizontal axis		Vertical axis		External perimeter complete	Page	-
		J_x (cm ⁴)	W_x (cm ³)	J_y (cm ⁴)	W_y (cm ³)						J_x (cm ⁴)	W_x (cm ³)	J_y (cm ⁴)	W_y (cm ³)			
	P 524118	815	72	72	33	607	37	-		P 599306	564	61	45	17	552	40	-
	P 524119	794	71	97	32	647	37	-		P 599317	787	74	50	19	602	40	-

033000300

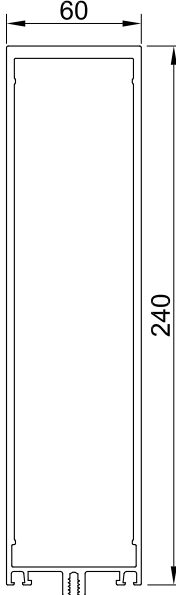
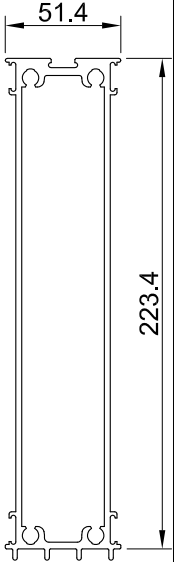
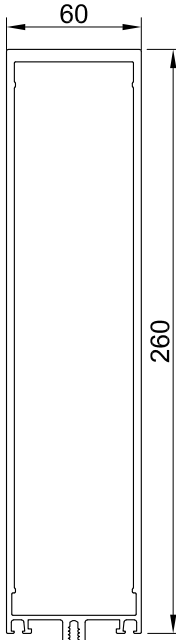
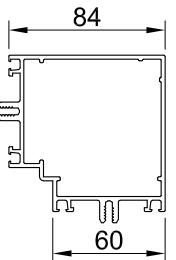
Profile overview and static profile values for Series Trigon 60

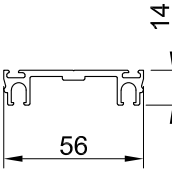
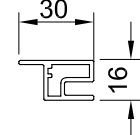
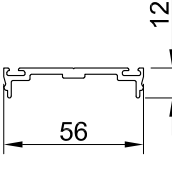
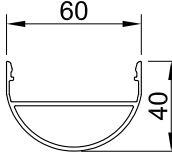
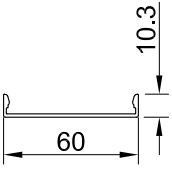
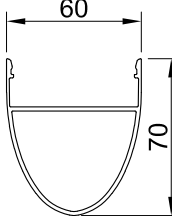
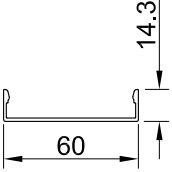
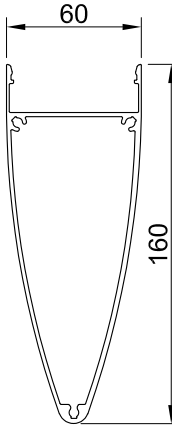
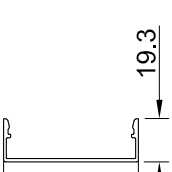
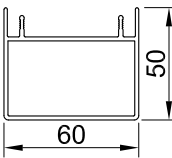
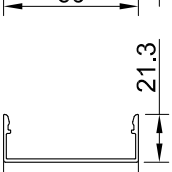
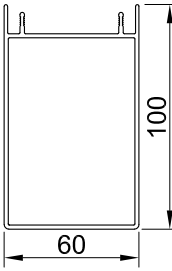
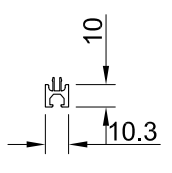
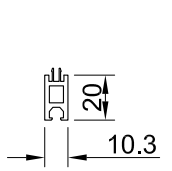

	Profile number	Horizontal axis		Vertical axis		External perimeter complete	Page		Profile number	Horizontal axis		Vertical axis		External perimeter complete	Page
		J_x (cm ⁴)	W_x (cm ³)	J_y (cm ⁴)	W_y (cm ³)					J_x (cm ⁴)	W_x (cm ³)	J_y (cm ⁴)	W_y (cm ³)		
	P 524125	1436	142	108	47	697	38		P 599312	1003	53	86	21	636	41
	P 524130	1767	153	124	51	737	38								
	P 523181	85	85	18	18	529	39								

Profile overview and static profile values for Series Trigon 60

 P 524117	Profile number	Horizontal axis		Vertical axis		External perimeter complete	Page -	 P 520259	Profile number	Horizontal axis		Vertical axis		External perimeter complete	Page -
		J_x (cm ⁴)	W_x (cm ³)	J_y (cm ⁴)	W_y (cm ³)					J_x (cm ⁴)	W_x (cm ³)	J_y (cm ⁴)	W_y (cm ³)		
	P 423430	-	-	-	-	226	44		P 520259	-	-	-	-	109	42
	P 423438	-	-	-	-	178	42		P 524166	-	-	-	-	214	43
	P 424104	-	-	-	-	159	42		P 524167	-	-	-	-	273	43
	P 423600	-	-	-	-	175	42		P 524168	-	-	-	-	441	43
	P 424171	-	-	-	-	199	42		P 560612	-	-	-	-	285	44
	P 423601	-	-	-	-	207	42		P 560613	-	-	-	-	381	44
	P 419900	-	-	-	-	82	42								
	P 519901	-	-	-	-	104	42								

0350006500

Profile overview and static profile values for Series Trigon 60

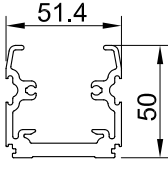
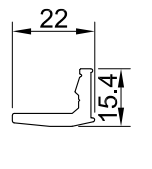
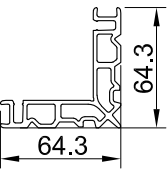
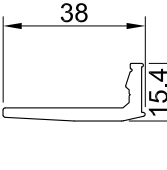
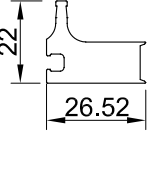
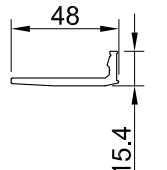
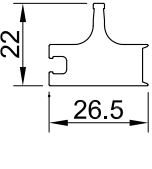
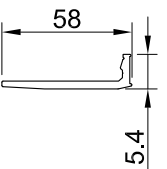
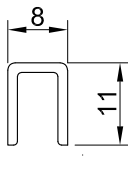
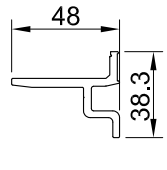
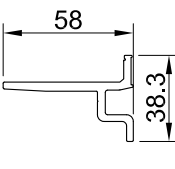
	Profile number	Horizontal axis		Vertical axis		External perimeter complete	Page		Profile number	Horizontal axis		Vertical axis		External perimeter complete	Page
		J_x (cm ⁴)	W_x (cm ³)	J_y (cm ⁴)	W_y (cm ³)					J_x (cm ⁴)	W_x (cm ³)	J_y (cm ⁴)	W_y (cm ³)		
	P 499620	-	-	-	-	408	45		P 499570	-	-	-	-	73	48
	P 599343	-	-	-	-	350	50		P 499562	-	-	-	-	105	48
	P 499758	-	-	-	-	105	49		P 499572	-	-	-	-	125	48
	P 499759	-	-	-	-	105	49		P 499587	-	-	-	-	145	48
	P 499760	-	-	-	-	56	49		P 499740	-	-	-	-	190	48
									P 499614	-	-	-	-	210	48

03600600

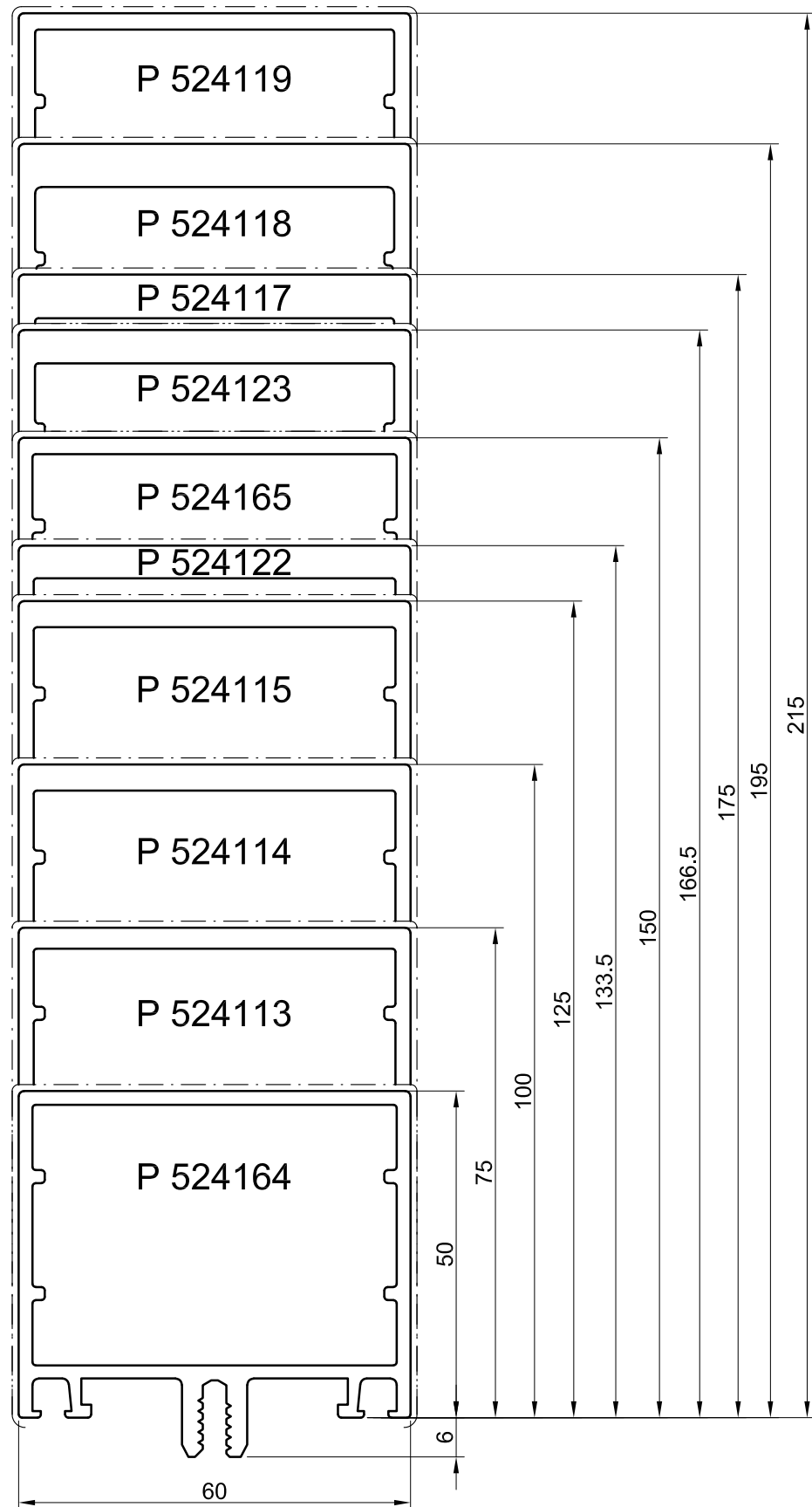

037000600

Scale 1:1

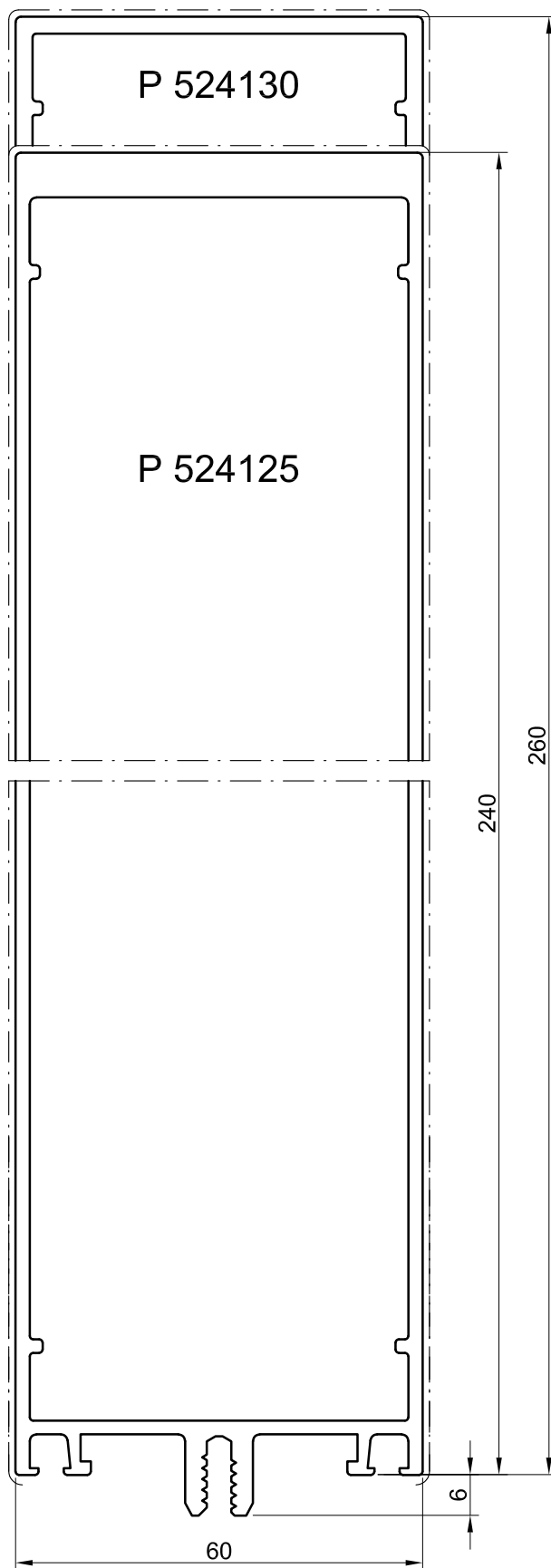

Scale 1:1

038000900

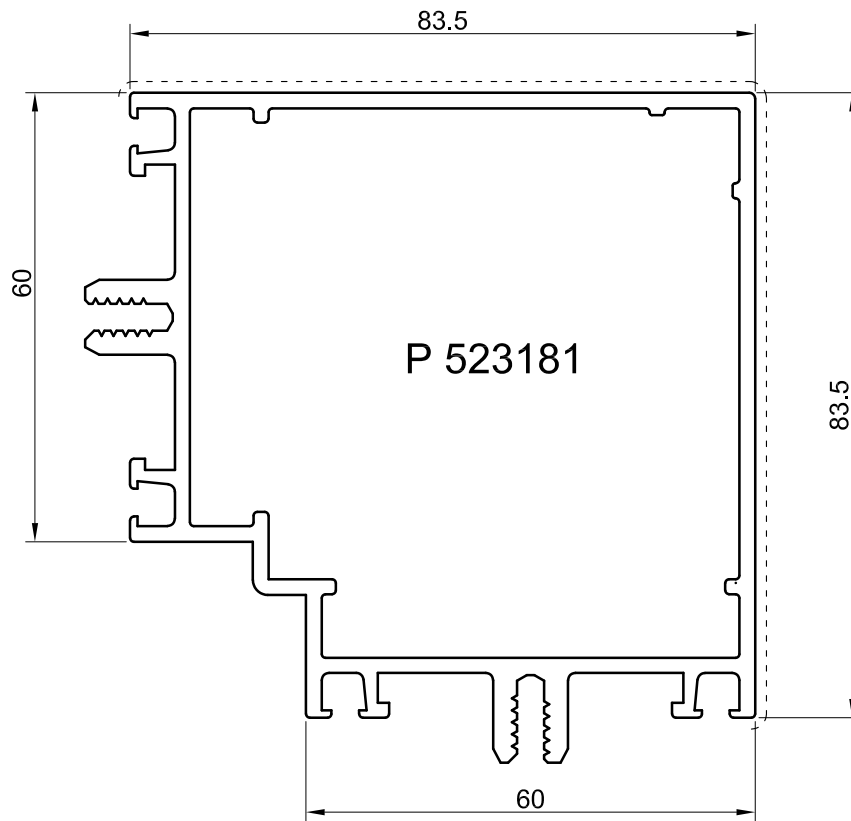

039001000

Scale 1:1

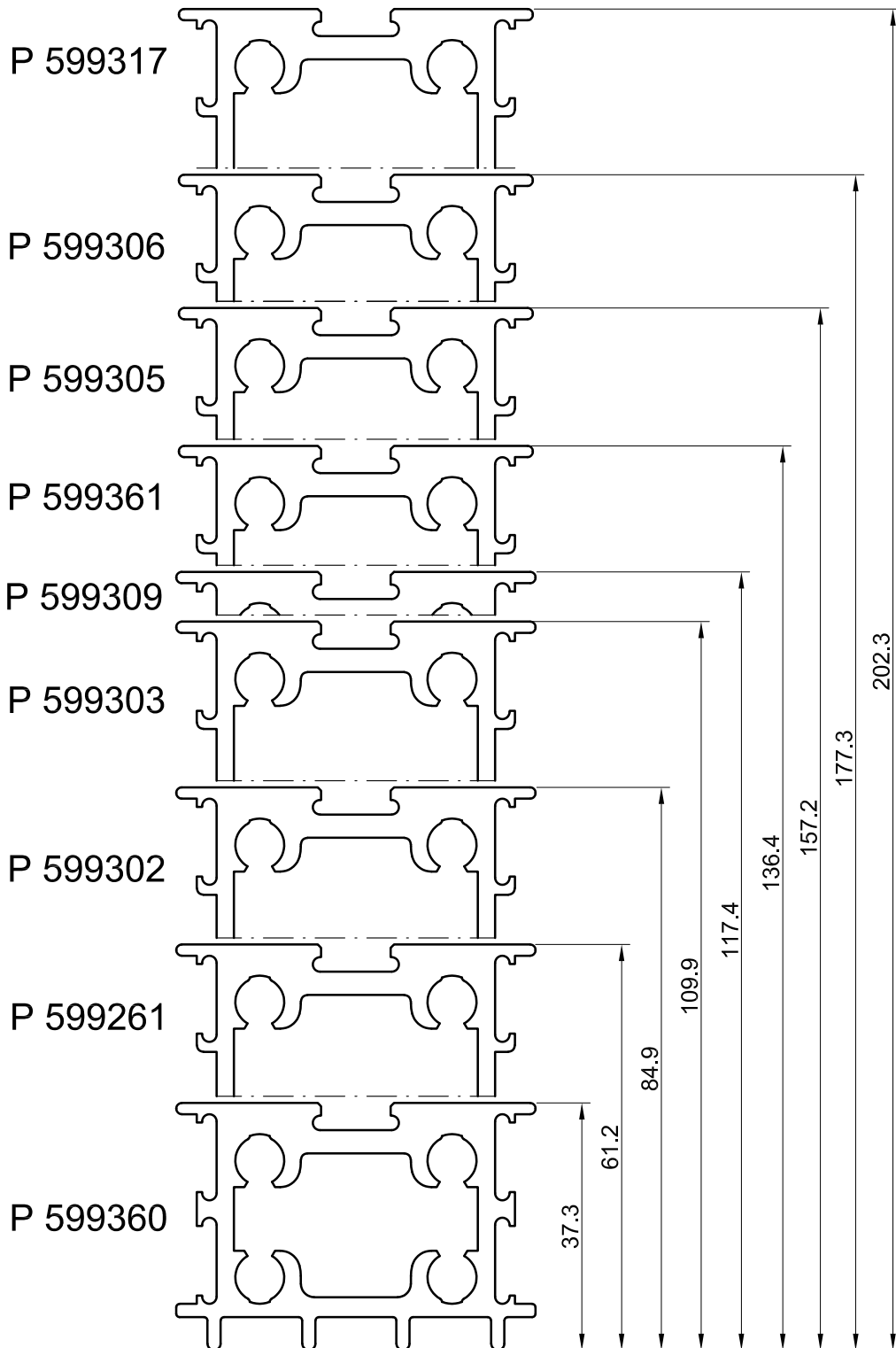

Scale 1:1

040001100

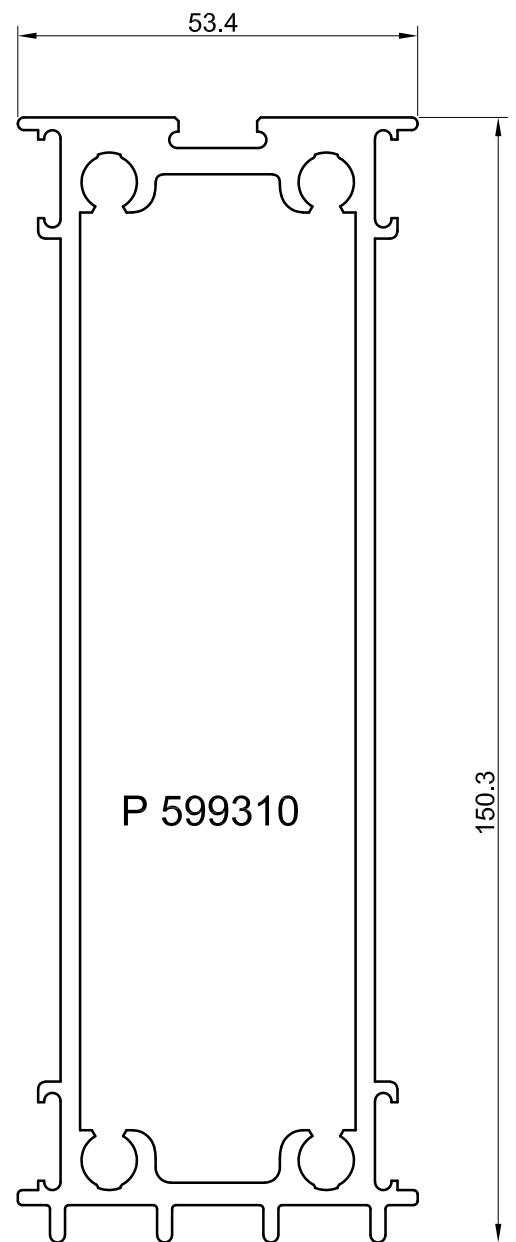
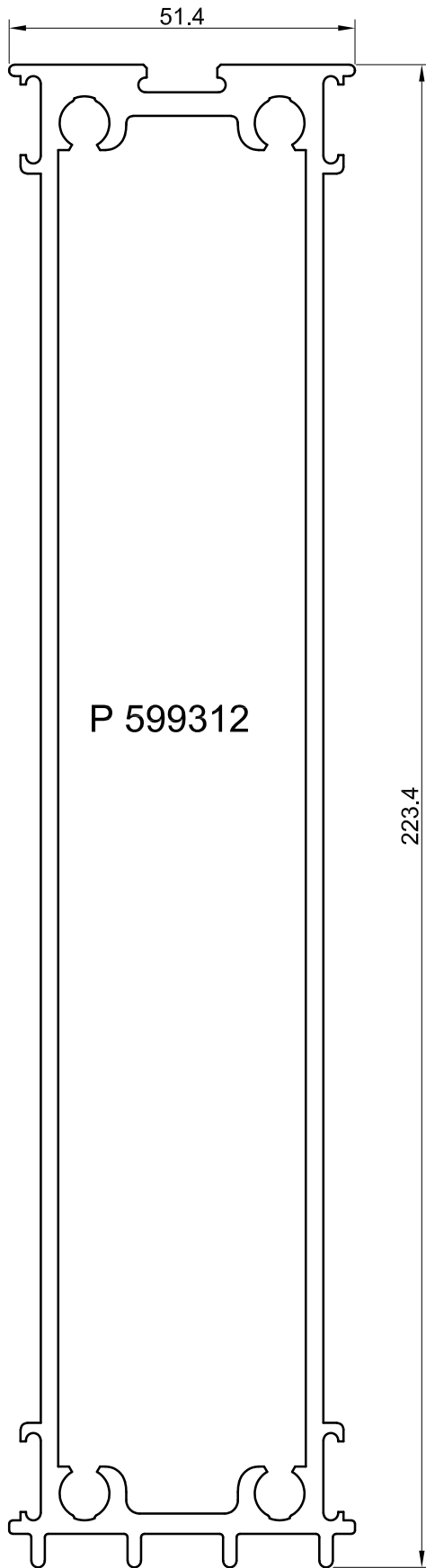

041001200

Scale 1:1

Snap-in cover profiles for P 423438

Pressure plate profiles for single gasket

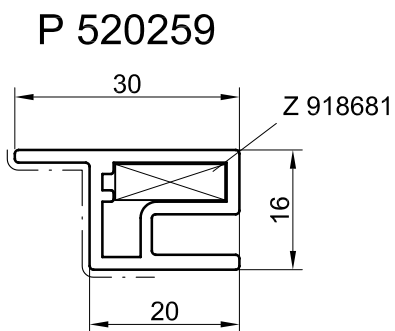
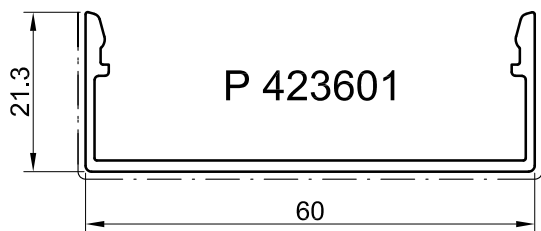
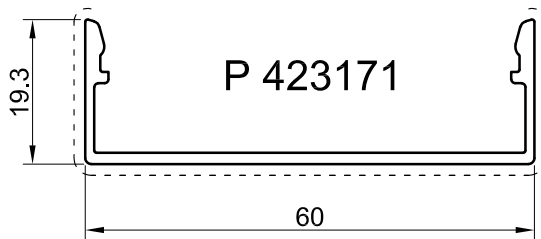
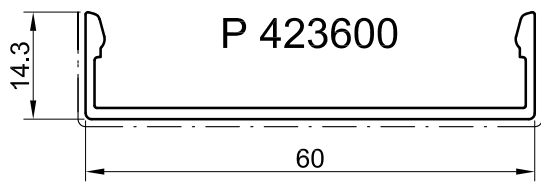
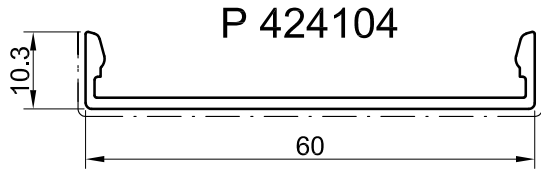

P 423430

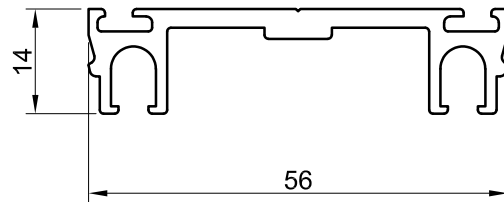

P 423438

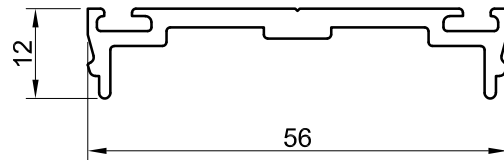

Supplementary profiles

P 419900

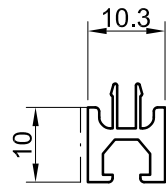

P 519901

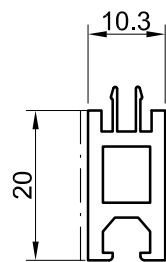

Scale 1:1

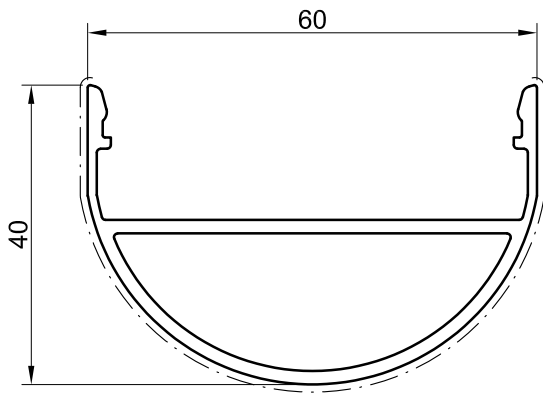

P 524166

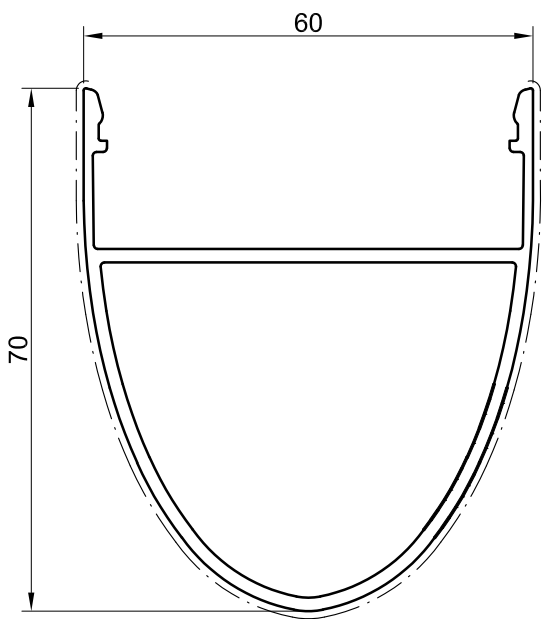

P 524167

P 524168

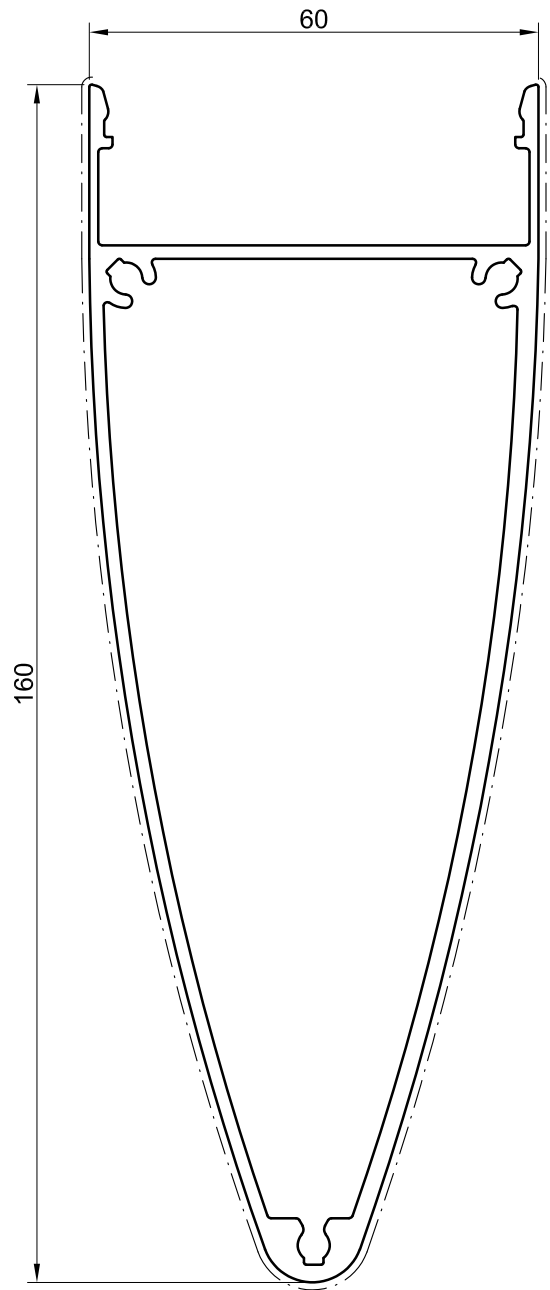

043001400

Scale 1:1

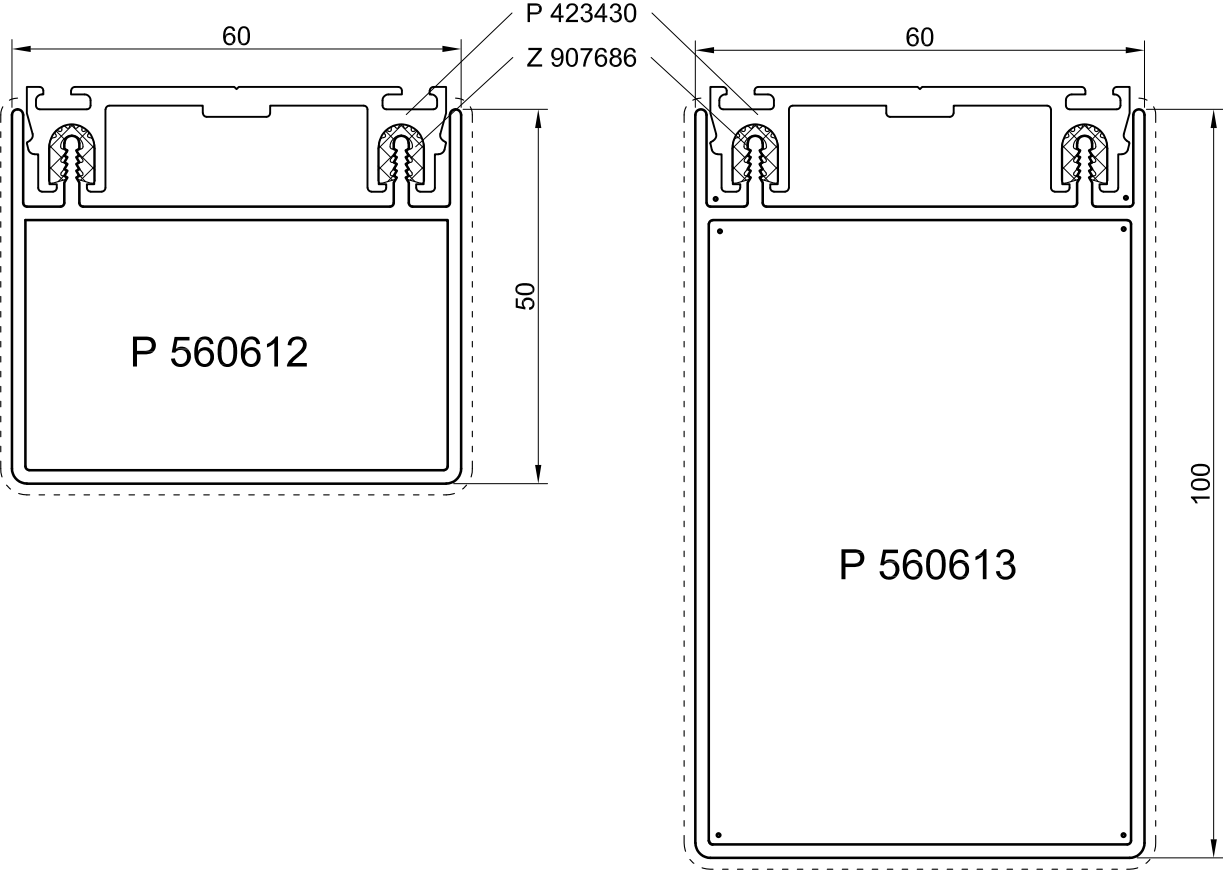

Scale 1:1

P 499620

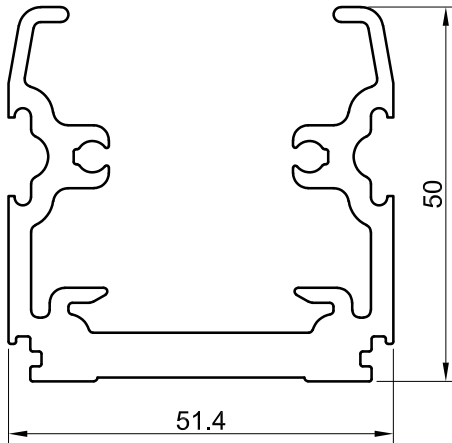

article no.:	profile no.:	length	pin
Z918582	P499620	38,6 mm	1 x 912865
Z918583	P499620	62,2 mm	2 x 912865

Z 918582

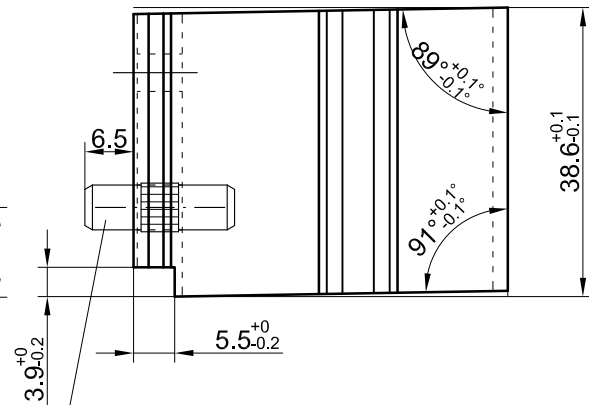
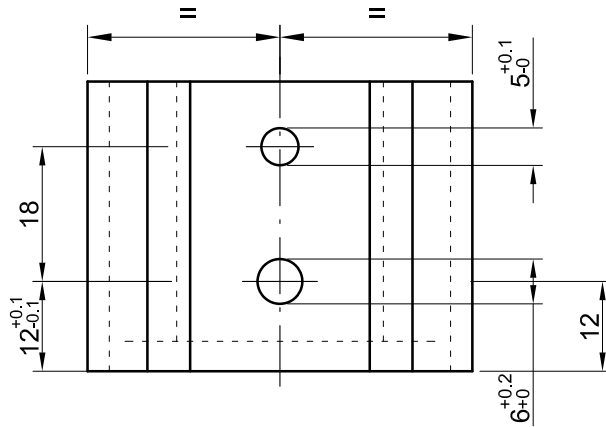

Z918583

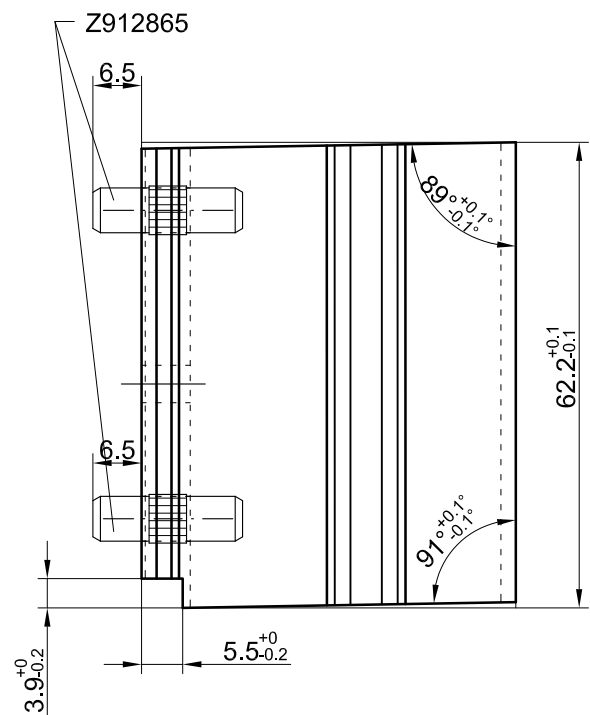
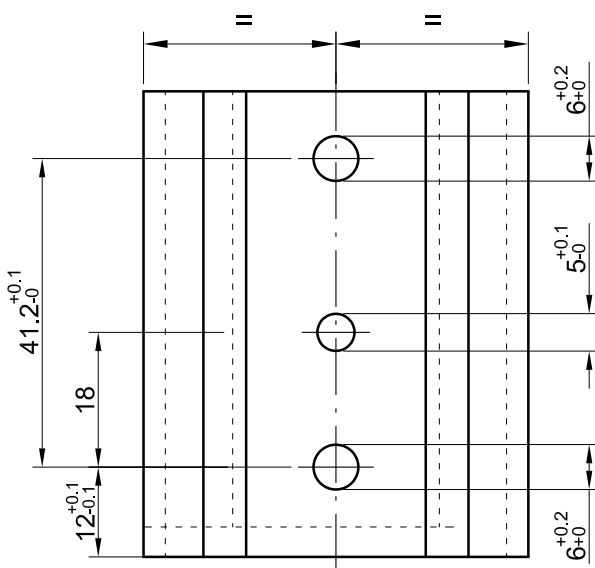

045001600

Scale 1:1

P 499620

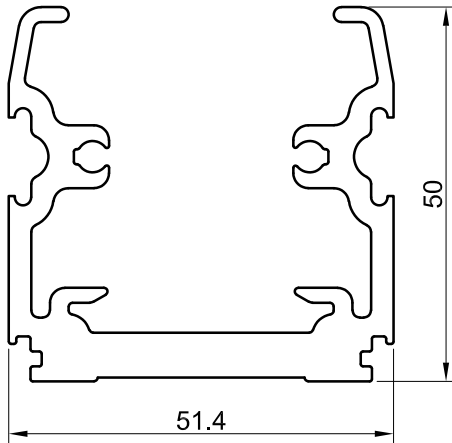

article no.:	profile no.:	length (X)	length (Y)	pin
Z918584	P499620	86,3 mm	68,0 mm	2 x 912865
Z918585	P499620	111,8 mm	68,0 mm	2 x 912865
Z918965	P499620	119,0 mm	68,0 mm	2 x 912865

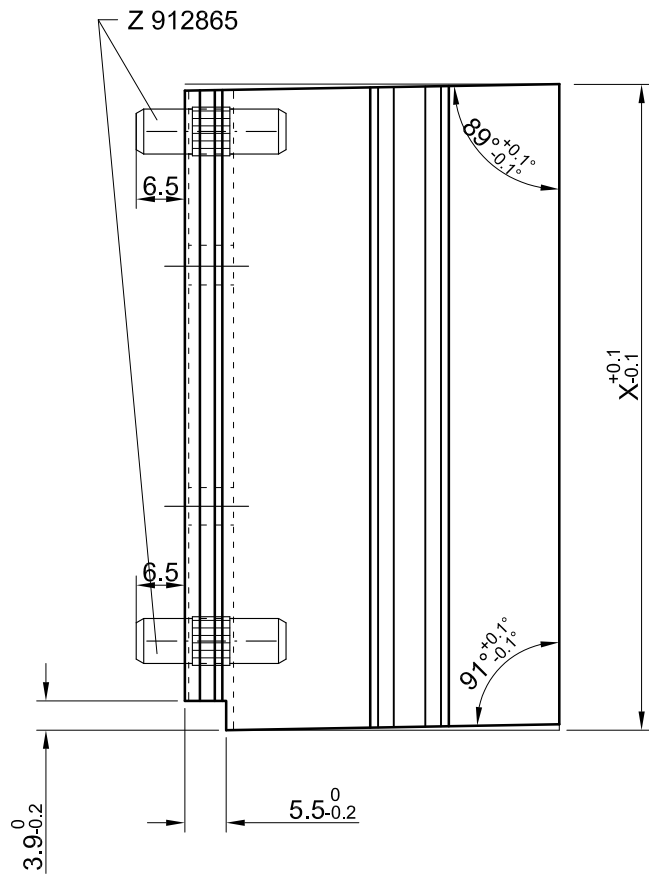
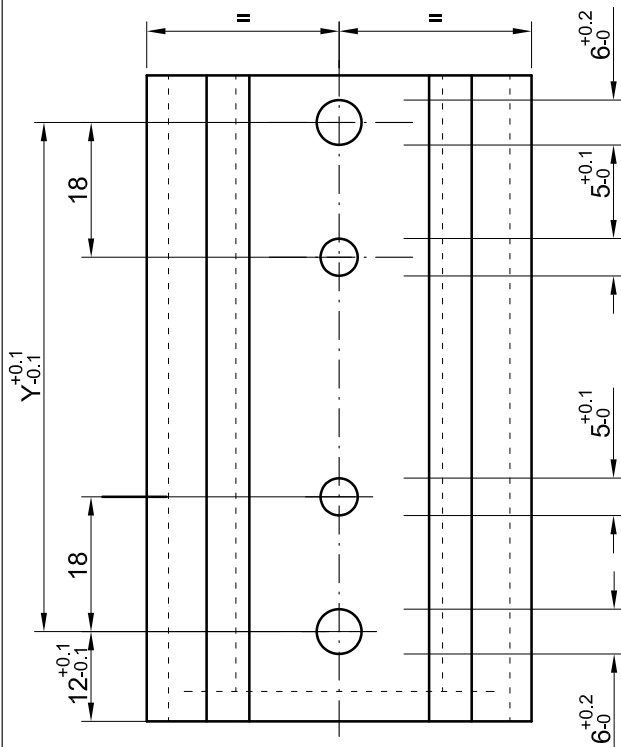

Scale 1:1

P 499620

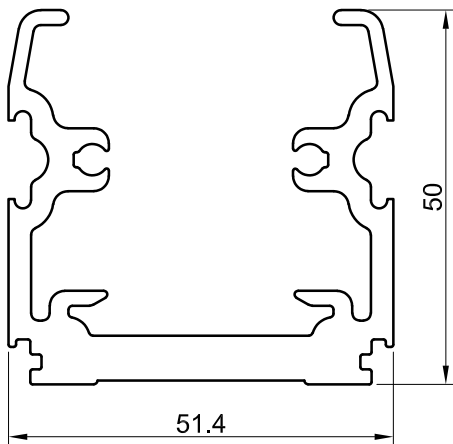

article no.:	profile no.:	length (X)	length (Y)	pin
Z918586	P499620	138,3 mm	101,0 mm	2 x 912865
Z918966	P499620	152,0 mm	101,0 mm	2 x 912865
Z918678	P499620	159,0 mm	130,8 mm	2 x 912865
Z918679	P499620	179,3 mm	130,8 mm	2 x 912865
Z918680	P499620	203,3 mm	130,8 mm	2 x 912865

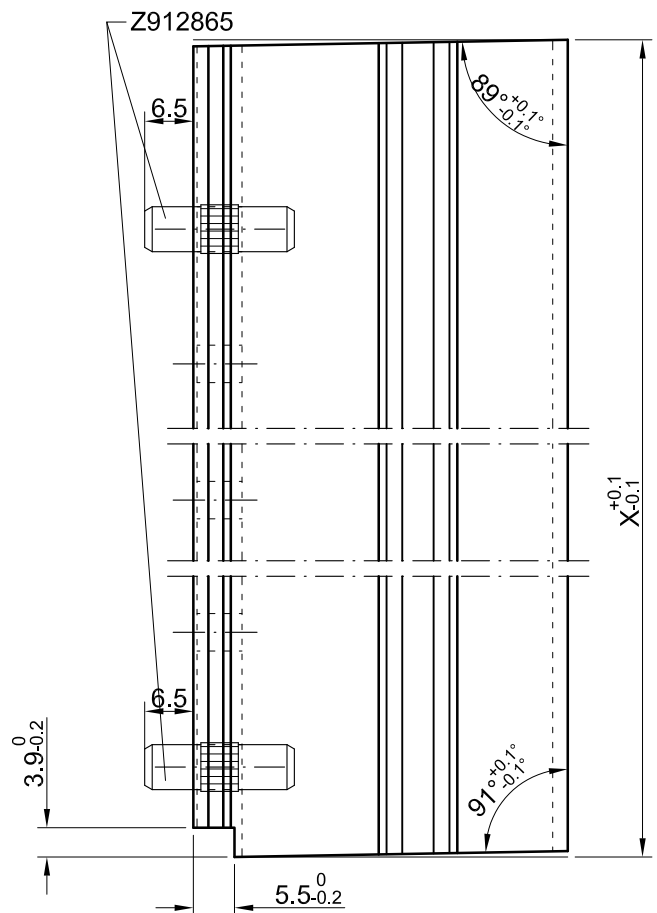
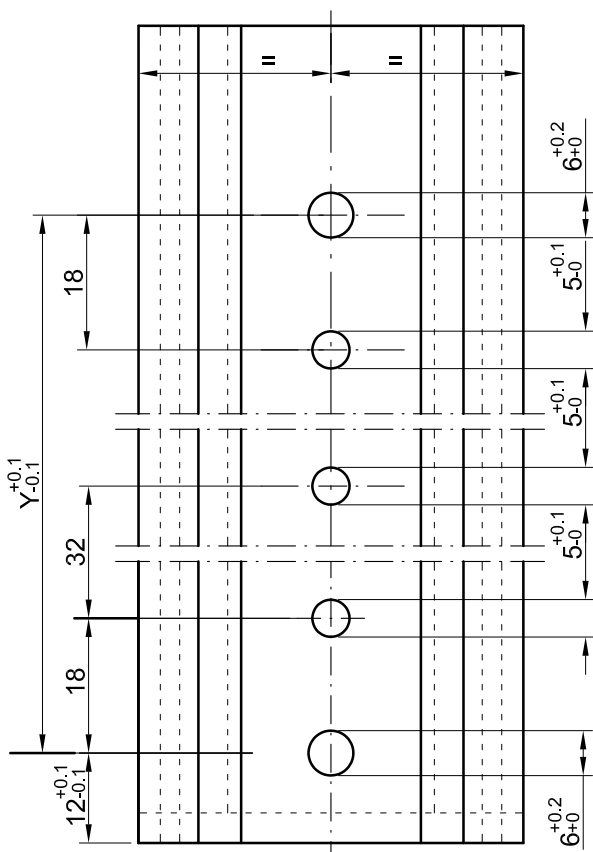

047001800

Scale 1:1

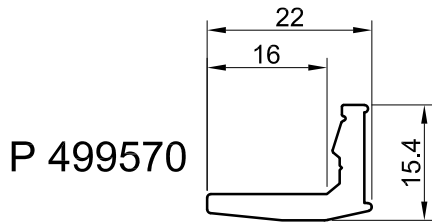

P 499570

article no.:	profile no.:	length
Z911909	P499570	100 mm

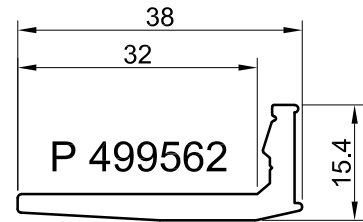

P 499562

article no.:	profile no.:	length
Z911910	P499562	100 mm

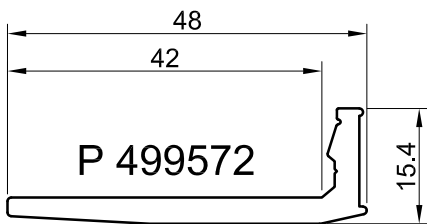

P 499572

article no.:	profile no.:	length
Z911911	P499572	100 mm

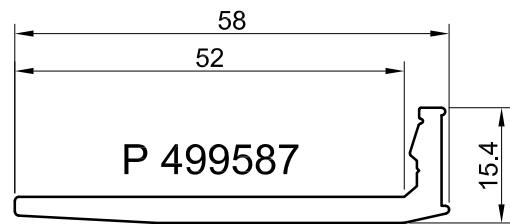

P 499587

article no.:	profile no.:	length
Z911985	P499587	100 mm

article no.:	profile no.:	length (X)	length (Y)	pad
Z997461	P499587	8 mm	50,0 mm	Z918560
Z997463	P499587	6 mm	52,0 mm	Z918560

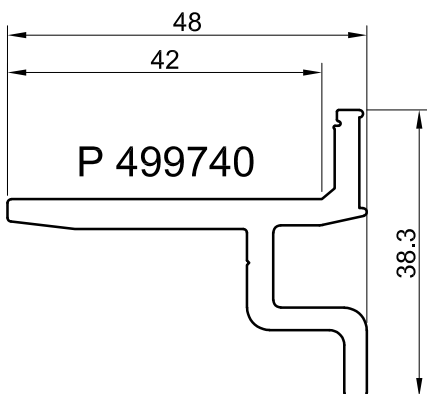
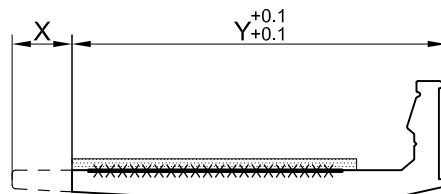

P 499740

article no.:	profile no.:	length
Z917053	P499740	100 mm

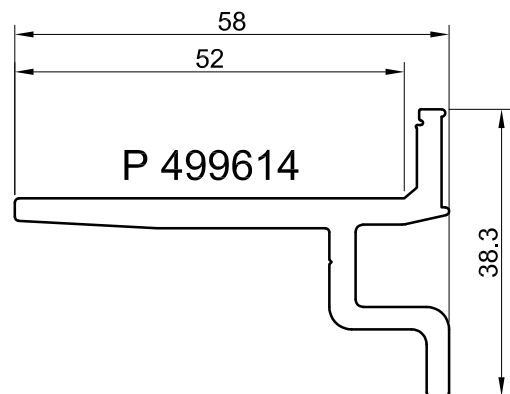

P 499614

article no.:	profile no.:	length
Z917054	P499614	100 mm

Scale 1:1

P 499758

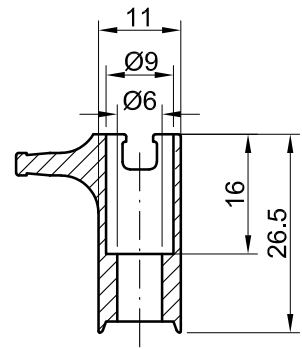
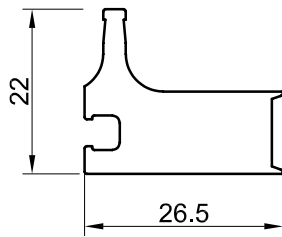

article no.:	profile no.:	length	gasket	screw
Z918577	P499758	35 mm	Z918588	2 x 911944

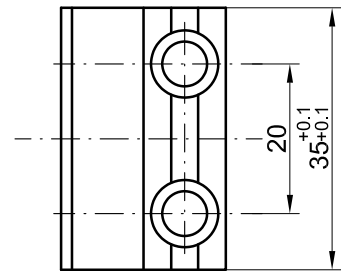

P 499759

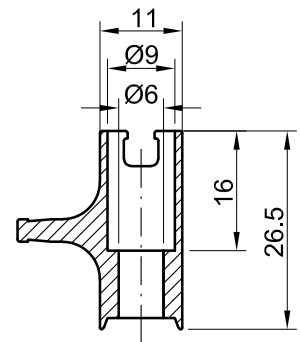
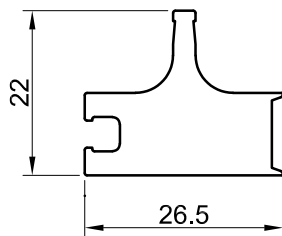

article no.:	profile no.:	length	gasket	screw
Z918576	P499759	35 mm	Z918588	2 x 911944

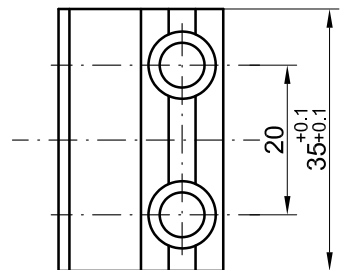

P 499760

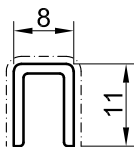

049002000

Scale 1:1

P 599343

article no.:	profile no.:	length
Z918681	P599343	4,8 mm

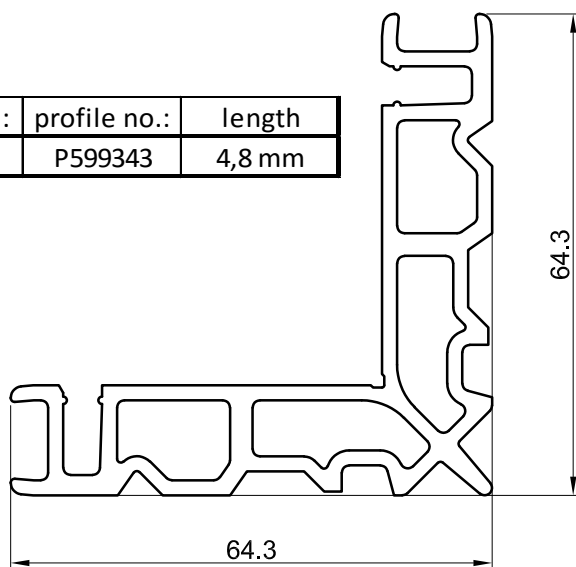

Scale 1:1

Spacer profile - polypropylene

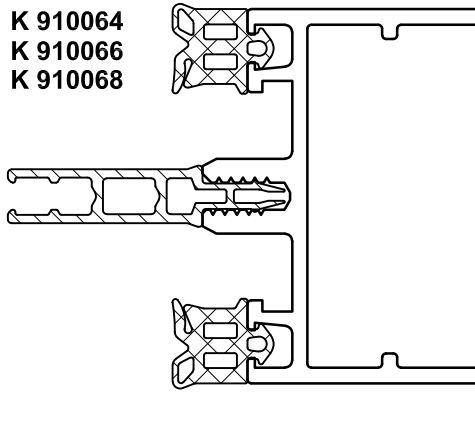
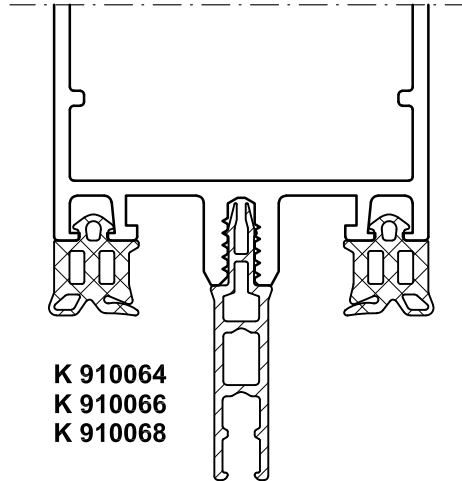

061000100

Attention!





The present document contains comments on glazing tables for the series **Trigon 50** and **Trigon 60**. As both series can be glazing identically to a large extent, any deviations are indicated as follows:

Trigon 50 = article number without brackets

Trigon 60 = article number in brackets ()

Profile numbers, article numbers for accessories and measurements without marking apply to both series.

Glazing table for Series Trigon 50 / Trigon 60

Pressure plate gaskets inside	Gap dimension 4 mm	Gap dimension 6 mm	Gap dimension 8 mm	Gap dimension 10 mm	Gap dimension 12 mm
	Z 912611 	Z 912612 	Z 912613 	Z 912614 	Z 912615 

Mullion rebate width 1)

Thickness of filling has to be checked before glazing. Gasket to be chosen correspondingly.

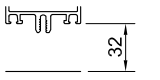
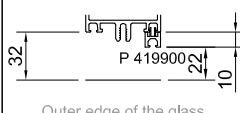
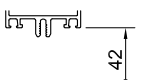
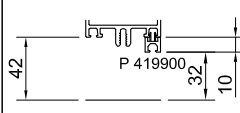
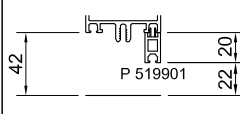
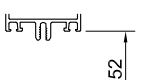
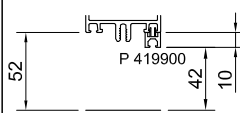
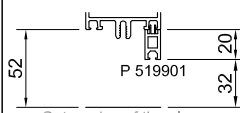
 Outer edge of the glass	12	10	8	6	4
 Outer edge of the glass	28	26	24	22	20
 Outer edge of the glass	18	16	14	12	10
 Outer edge of the glass	38	36	34	32	30
 Outer edge of the glass	28	26	24	22	20
 Outer edge of the glass	18	16	14	12	10
 Outer edge of the glass	48	46	44	42	40
 Outer edge of the glass	38	36	34	32	30
 Outer edge of the glass	28	26	24	22	20

1) The transom's rebate width is -1 mm and is compared by means of the internal glazing gasket

Glazing table for Series Trigon 50 / Trigon 60

Pressure plate profiles outside

for single gaskets

P 419438

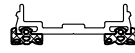

Z 912616

Screws, glass support, Insulating

Mullion rebate width 1)

Thickness of filling has to be checked before glazing. Gasket to be chosen correspondingly.

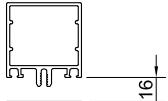

Outer edge of the glass

Z 911934

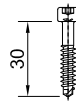

**Z 911809
(Z 911909)**



Spacer profile
K 910064

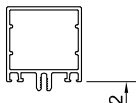

Outer edge of the glass

Z 911936

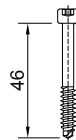

**Z 911810
(Z 911910)**

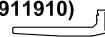

Spacer profile
K 910066

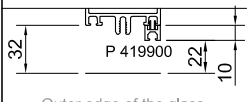
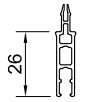

Outer edge of the glass

Z 912727

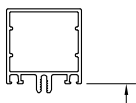
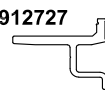

Outer edge of the glass

Z 911938

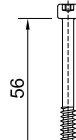

**Z 911811
(Z 911911)**

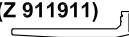

Spacer profile
K 910068

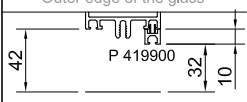
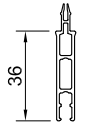

Outer edge of the glass

**Z 912728
(Z 917053)**

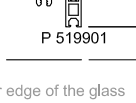
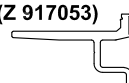

Outer edge of the glass

Z 911897

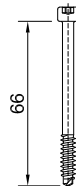

**Z 911898
(Z 911985)**

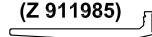

Spacer profile
K 910068

+
K 910064

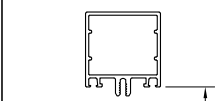
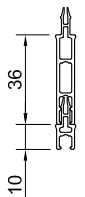

Outer edge of the glass



Outer edge of the glass

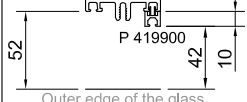

Outer edge of the glass

063000300



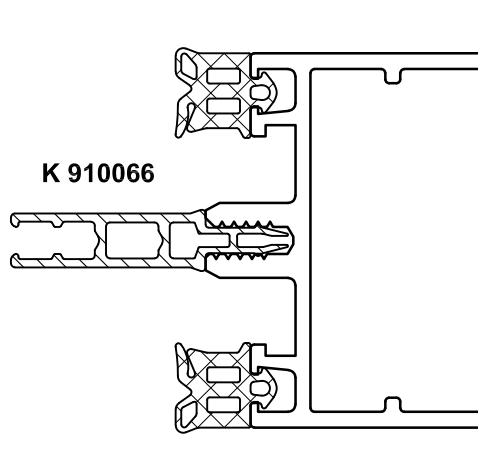
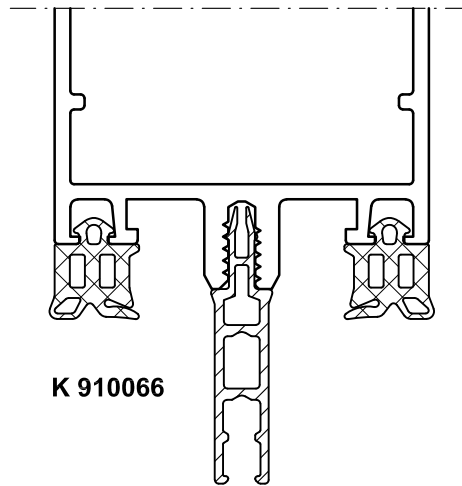

1) The transom's rebate width is -1 mm and is compensated by means of the internal glazing gasket

Spacer profile - polypropylene

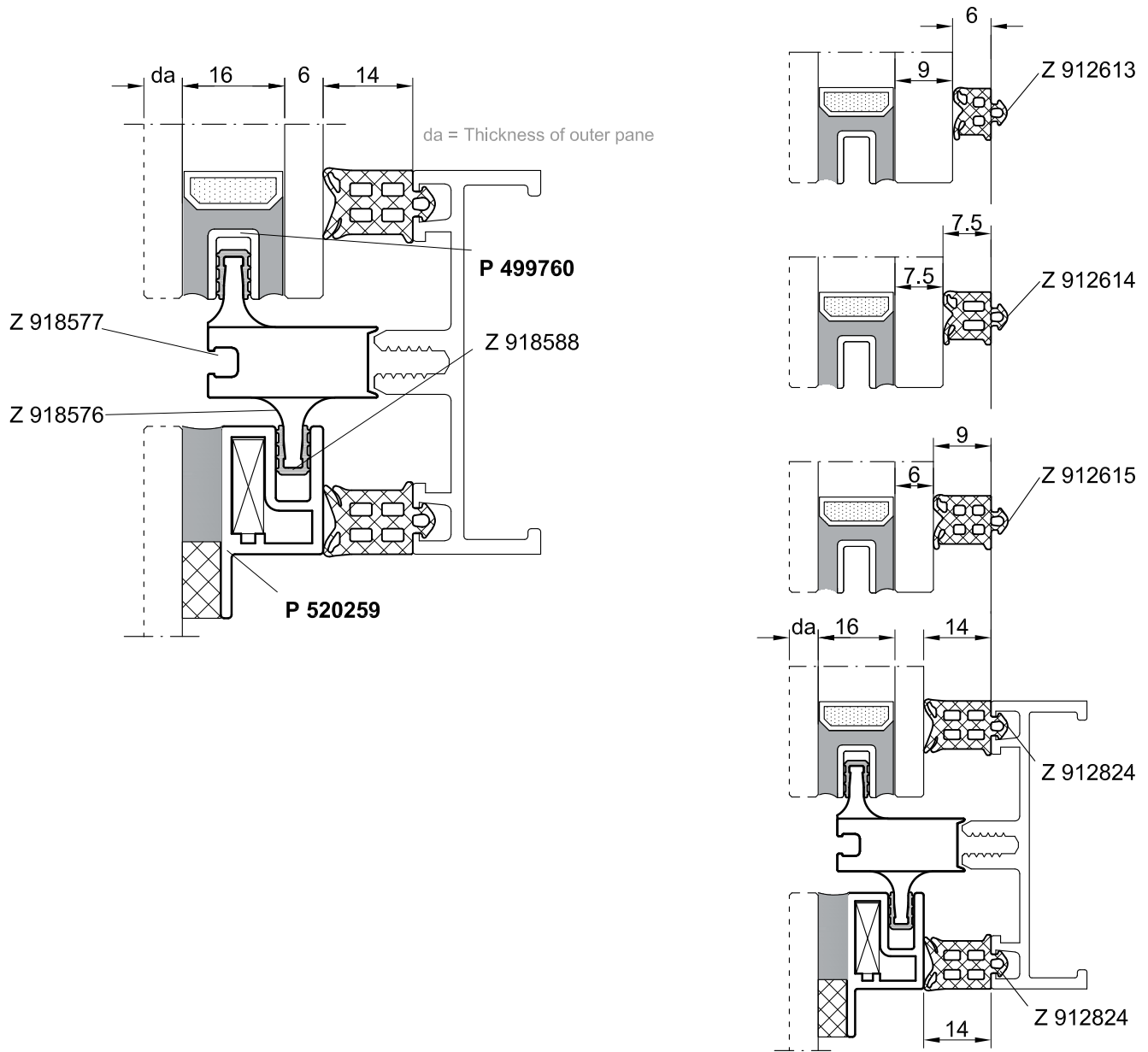

0650006500



Internal glazing gasket				
Glass thickness internal pane	6 mm	8 mm	10 mm	12 mm
Glazing gasket	Z 912824 14 mm 	Z 912615 12 mm 	Z 912614 10 mm 	Z 912613 8 mm 

The outer pane must be supported at least half its thickness by glazing supports.

Trigon 50 Trigon 60

	outer glass thickness	Glass support reduced (x)	Glass support	Glass support
single glass	6	3	Z 997468	Z 997461
	8	2		
	10	1		
	12	0		
All dimensions in mm				

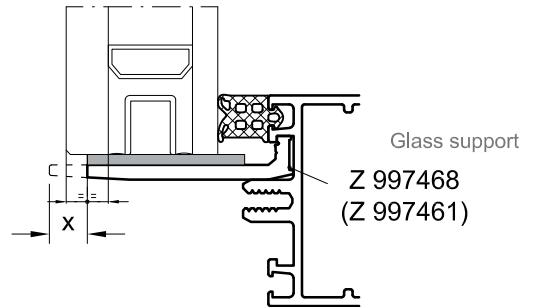

Trigon 50 Trigon 60

	outer glass thickness	Glass support reduced (x)	Glass support	Glass support
laminated glass	8.8	3	Z 997462	Z 997463
	10.8	1.5		
	12.8	0		
All dimensions in mm				

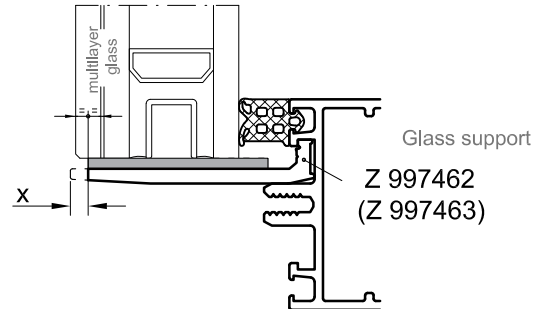

Trigon 50 Trigon 60

	outer glass thickness	Glass support reduced (x)	Glass support	Glass support
single glass	6	3	Z 997468	Z 997461
	8	2		
	10	1		
	12	0		
All dimensions in mm				

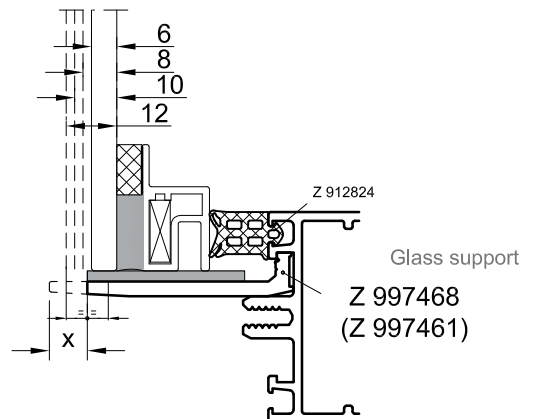

Layout according to EN 13022

During cutting the glass support, no aggressive agent are acceptabl. All residues have to be removed.
Please mind silicone-compatibility.

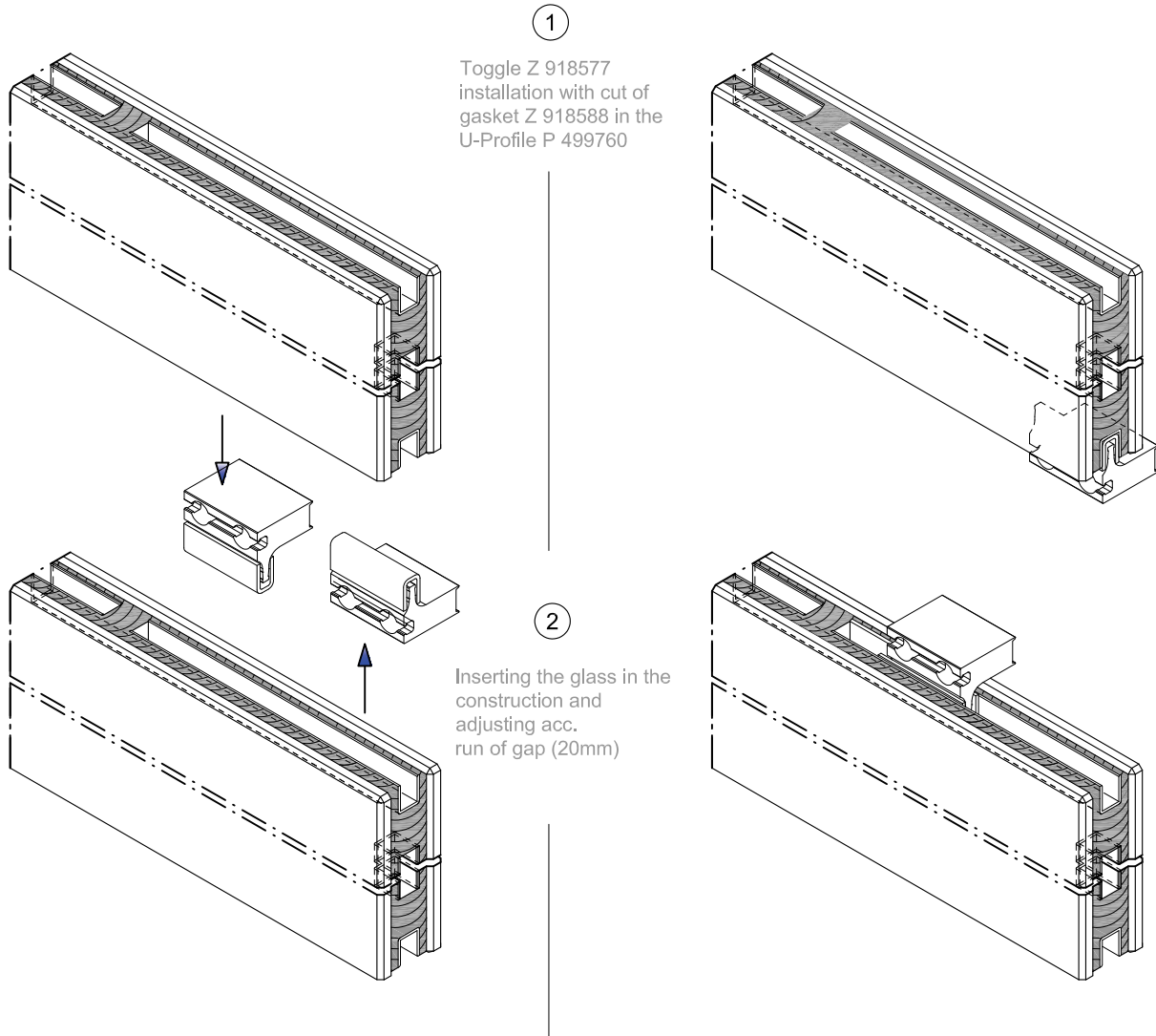

Variations of possible U-Profile arrangements

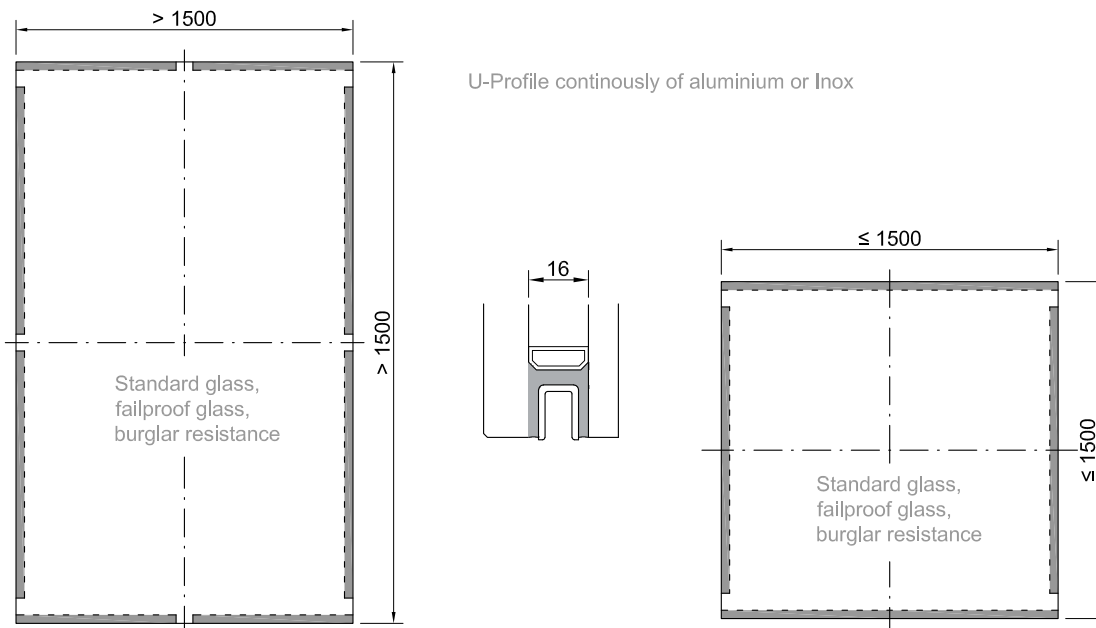

068000800

Standard

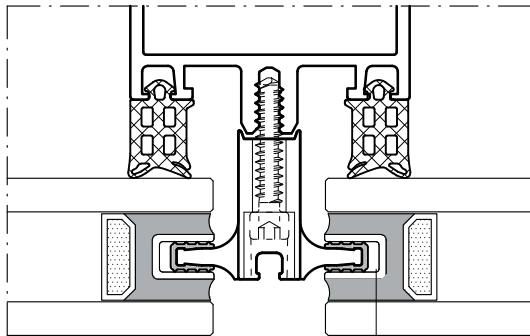

P 499760

Glazing with continous U - profile

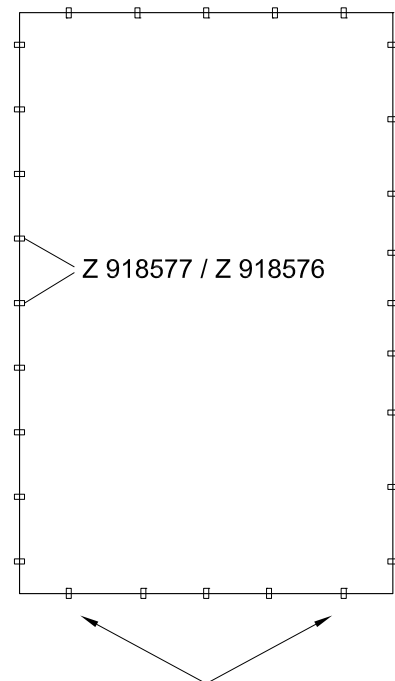
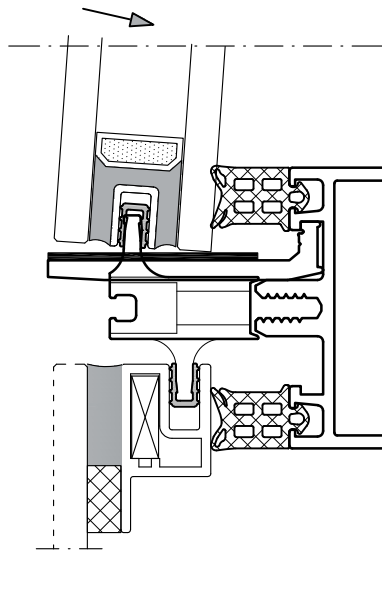
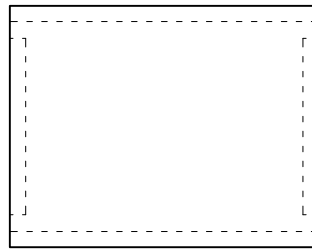

Toggle mounting starting in the bottom glass corners

Pay attention to exactly positioning of the glass in its final position

Glass support with silicon block.

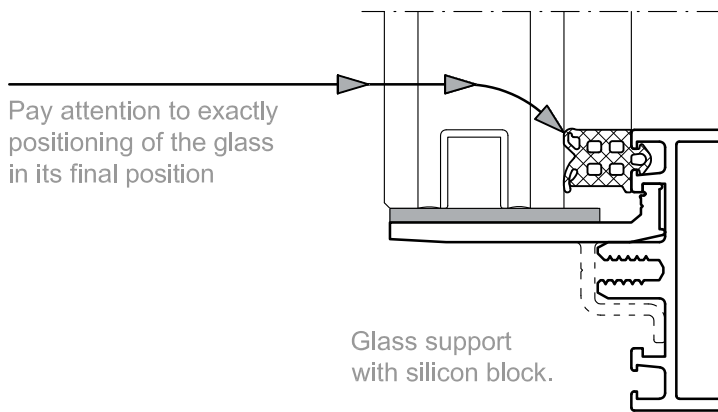

0690009600

Standard subconstruction Trigon 50 / 60

Silikon silicone

Dow Corning
DC791 / DC757
Sikasil
WS-605 S / 680 SC

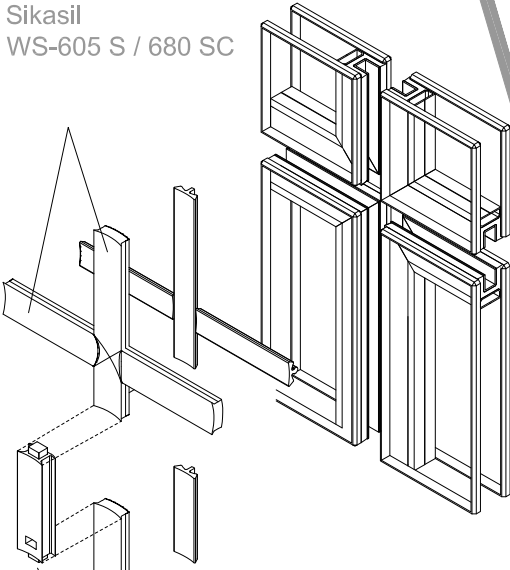

Z 918652

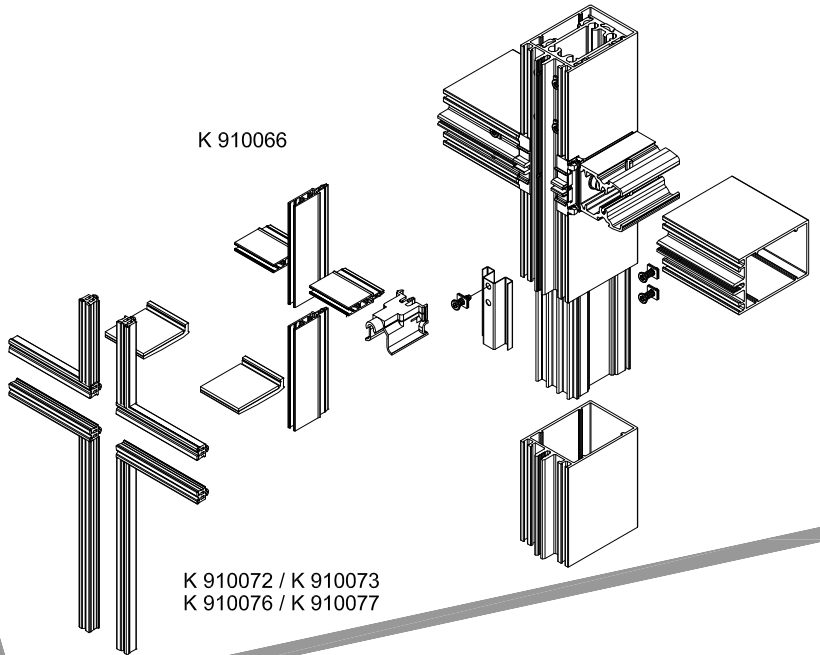

K 910066

K 910072 / K 910073
K 910076 / K 910077

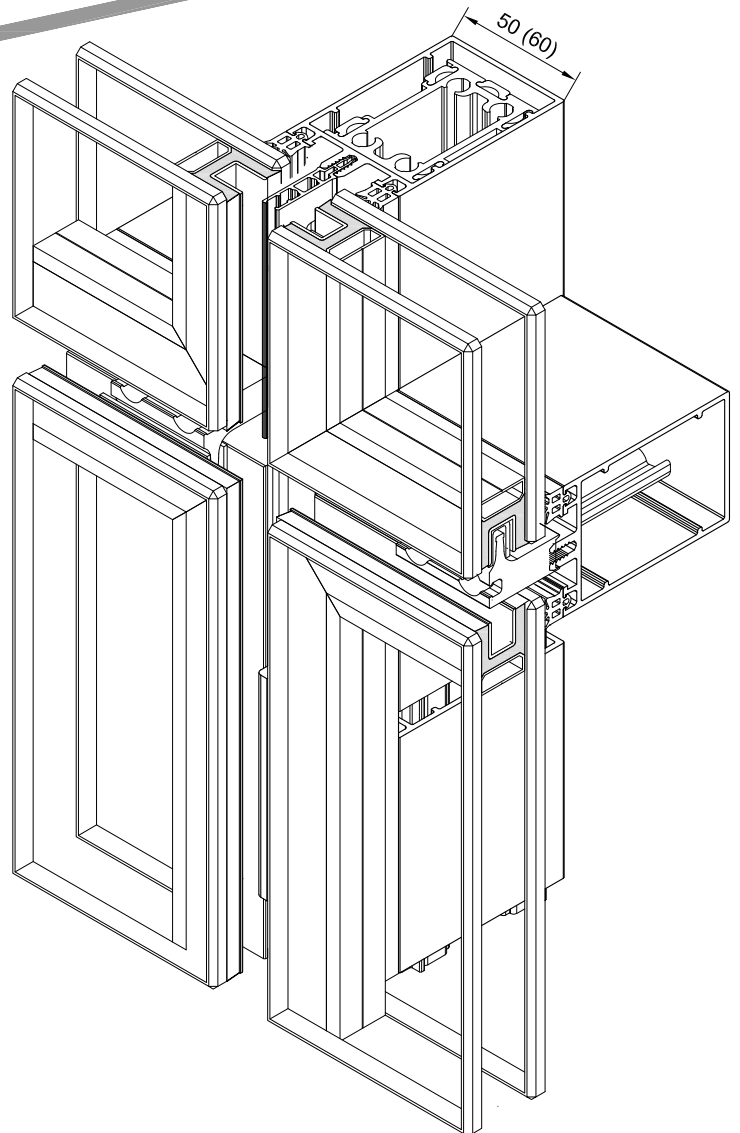

071001100

Profile combination as well as system processing - see catalogue Trigon

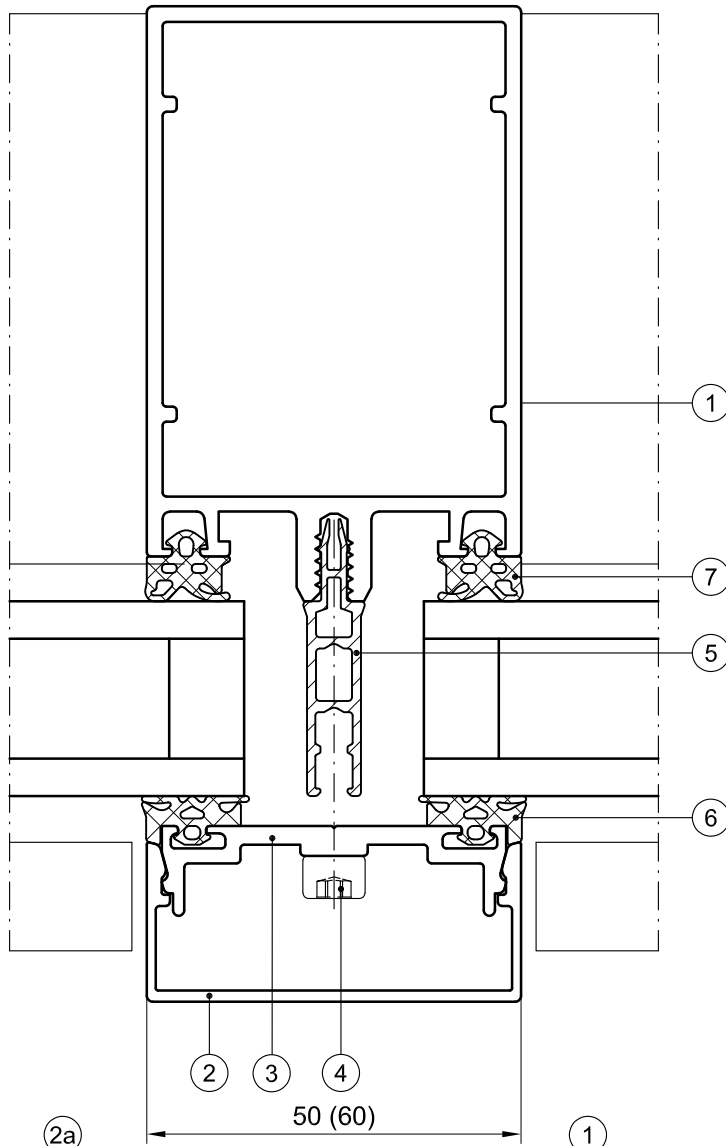
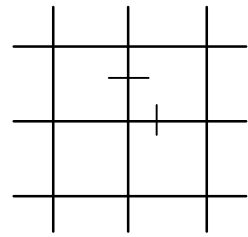

- ① Mullion profile / Transom profile
- ② Snap in cover profile
- ②a Snap in cover profile
- ③ Pressure plate profile
- ④ Façade fixing screw, cf. glazing tables
- ⑤ Spacer profile, cf. glazing tables
- ⑥ Pressure plate glazing gasket
- ⑦ Internal glazing gasket, cf. glazing tables

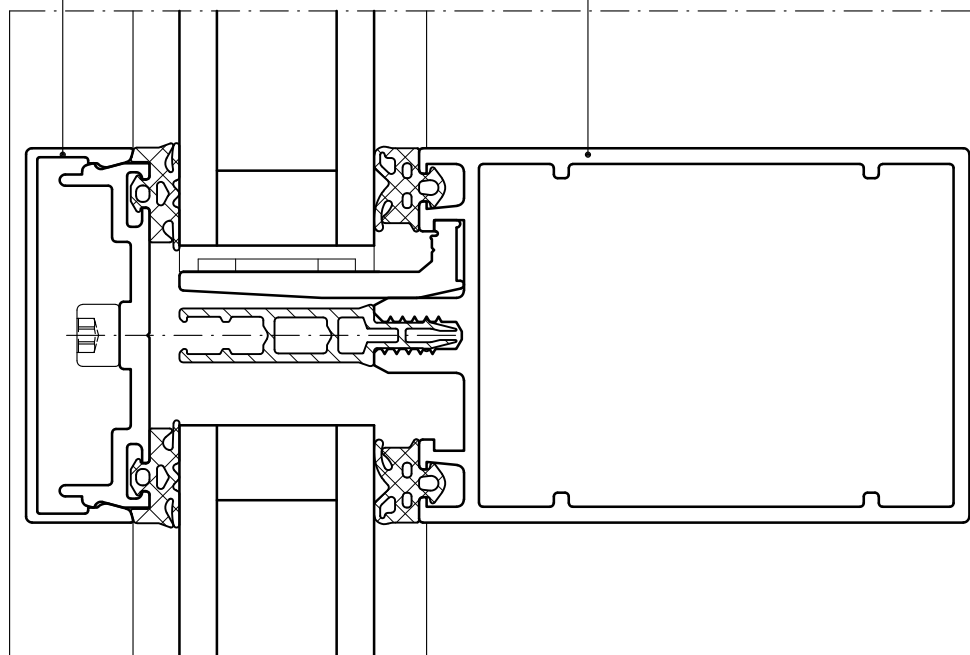

081000100

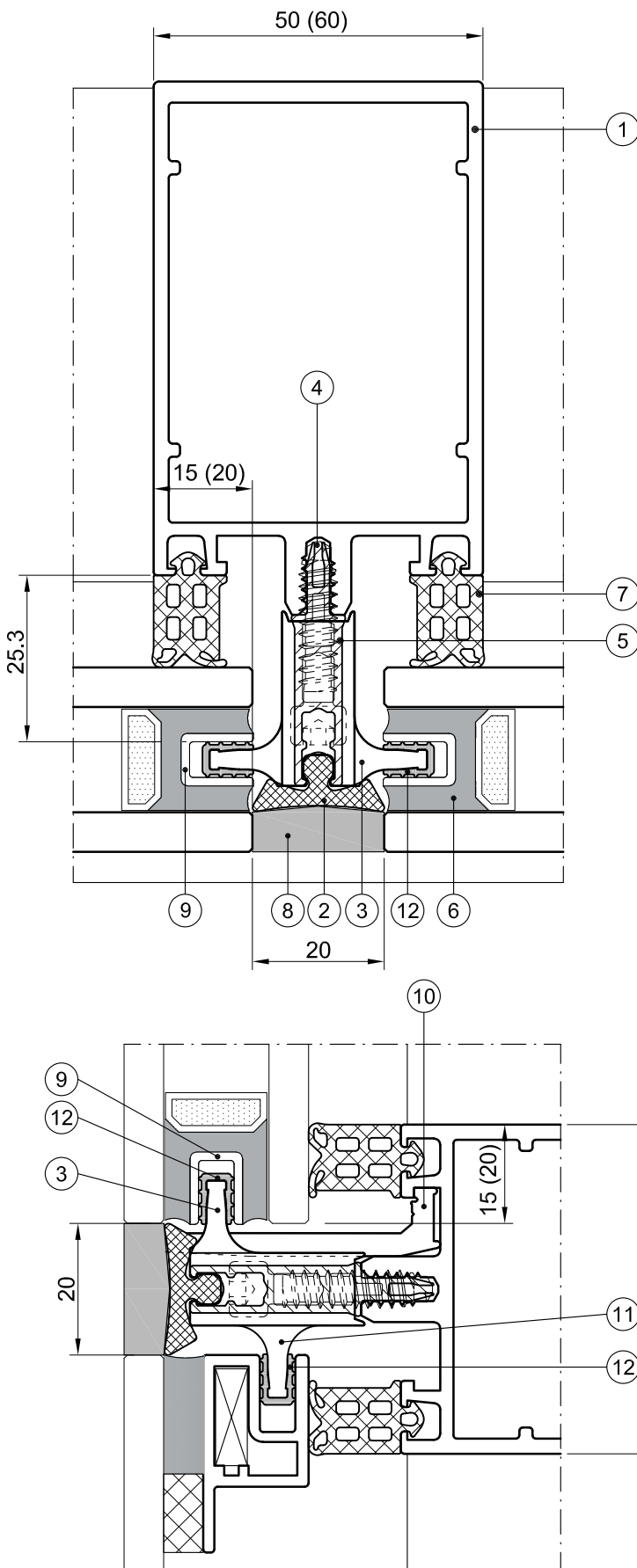
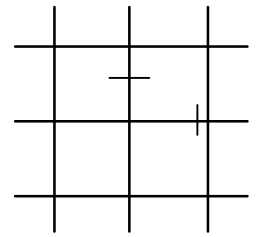

- ① Mullion profile / Transom profile
- ② Sealing gasket Z 914399
- ③ Single toggle Z 918577
- ④ Façade fixing screw
- ⑤ Spacer profile, cf. façade glazing tables
- ⑥ Sealant
- ⑦ Internal glazing gasket, cf. façade glazing tables
- ⑧ Sealant
- ⑨ Alu U-profile P 499760
- ⑩ Glass support
- ⑪ Single toggle Z 918576
- ⑫ Toggle gasket Z 918588

Scale 1:1

Façade series Trigon

Glazing gaskets - internal -



Z 912611 22

Glazing gasket
made of EPDM, black,
Surface: siliconized
for gap dimensions of 4 mm,
can be used in accordance with the
glazing table
Z 912611 22 0002 coiled to the left
Z 912611 22 0003 coiled to the right

Z 912816 22

Gasket frame
made of profile Z 912611
for gap dimensions of 4 mm,
(Surface siliconized)
Please indicate frame dimension "a"
when placing your order! - see figure -
(Please note the delivery time)

50	60	
50 SG	60 SG	



Z 912612 22

Glazing gasket
made of EPDM, black,
Surface: siliconized
for gap dimensions of 6 mm,
can be used in accordance with the
glazing table
Z 912612 22 0002 coiled to the left
Z 912612 22 0003 coiled to the right

Z 912812 22

Gasket frame
made of profile Z 912612
for gap dimensions of 6 mm,
(Surface siliconized)
Please indicate frame dimension "a"
when placing your order! - see figure -
(Please note the delivery time)

50	60	
50 SG	60 SG	



Z 912613 22

Glazing gasket
made of EPDM, black,
Surface: siliconized
for gap dimensions of 8 mm,
can be used in accordance with the
glazing table
Z 912613 22 0002 coiled to the left
Z 912613 22 0003 coiled to the right

Z 912813 22

Gasket frame
made of profile Z 912613
for gap dimensions of 8 mm,
(Surface siliconized)
Please indicate frame dimension "a"
when placing your order! - see figure -
(Please note the delivery time)

50	60	
50 SG	60 SG	



Z 912614 22

Glazing gasket
made of EPDM, black,
Surface: siliconized
for gap dimensions of 10 mm,
can be used in accordance with the
glazing table
Z 912614 22 0002 coiled to the left
Z 912614 22 0003 coiled to the right

Z 912814 22

Gasket frame
made of profile Z 912614
for gap dimensions of 10 mm,
(Surface siliconized)
Please indicate frame dimension "a"
when placing your order! - see figure -
(Please note the delivery time)

50	60	
50 SG	60 SG	



Z 912615 22

Glazing gasket
made of EPDM, black,
Surface: siliconized
for gap dimensions of 12 mm,
can be used in accordance with the glazing table
Z 912615 22 0002 coiled to the left
Z 912615 22 0003 coiled to the right

Z 912815 22

Gasket frame
made of profile Z 912615
for gap dimensions of 12 mm,
(Surface siliconized)
Please indicate frame dimension "a"
when placing your order! - see figure -
(Please note the delivery time)

50	60	
50 SG	60 SG	



Z 912824 22

Glazing gasket
made of EPDM, black,
Surface: siliconized
for gap dimensions of 14 mm,
can be used in accordance with the
glazing table

Figure order dimension "a"

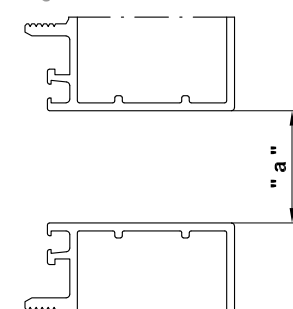

50	60	
50 SG	60 SG	

Installation: refer to Processing Information

101000100

Z 912616 22



External pressure plate gasket,
made of EPDM, black,
Surface: siliconized
can be used for pressure plate profiles
with single gaskets
Z 912616 22 0002 coiled to the left
Z 912616 22 0003 coiled to the right

50	60	

Z 906789 25



Rubber clip piece, metre length material,
made of EPDM, black,
suitable for the assembly of cover
profiles

50	60	

Z 907686 25



Rubber clip piece,
manufactured from Z 906789,
length 50 mm
maximum distance between the clip
pieces 250mm

50	60	

Z 912630 22

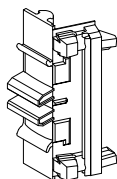

Transom housing gasket,
for sealing transom joints
made of EPDM, black,
Surface: siliconized

50		
50 SG		

Z 914086 22

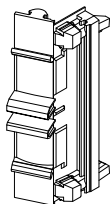

Transom housing gasket,
for sealing transom joints
made of EPDM, black,
Surface: siliconized

	60	
	60 SG	

Installation: refer to Processing Information

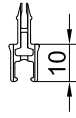

K 910064

Spacer profile,
colour: black,
length: 6500 mm
can be used in accordance with the
glazing table

50	60	

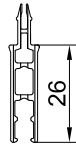

K 910066

Spacer profile,
colour: black,
length: 6500 mm
can be used in accordance with the
glazing table

50	60	
50 SG	60 SG	

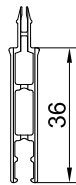

K 910068

Spacer profile,
colour: black,
length: 6500 mm
can be used in accordance with the
glazing table

50	60	



Z 900282

Sliding PVC guide profile,
for connection pieces

50	60	
50 SG	60 SG	

Façade series Trigon

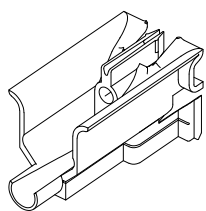

Shaped piece for field-by-field ventilation	
Article number	Rebate width
Z 912627	32 mm
Z 912628	42 mm
Z 912629	52 mm

50		

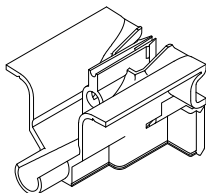

Shaped piece for field-by-field ventilation	
Article number	Rebate width
Z 914178	32 mm
Z 914179	42 mm
Z 914180	52 mm

	60	

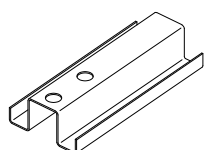

Z 912634

Drainage profile,
for straight - joint, Al
length 60 mm

50		

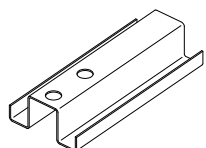

Z 912943

Drainage profile,
for straight - joint, Al
length 60 mm

	60	

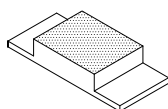

Z 912625

Sealing pad,
46 x 20 x 8 mm
EPDM - cellular rubber,
self - adhesive on one side

50		

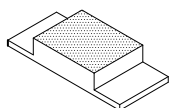

Z 912917

Sealing pad,
56 x 20 x 8 mm
EPDM - cellular rubber,
self - adhesive on one side

	60	

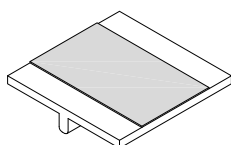

Z 912624

Sealing piece,
50 x 46 x 5 mm
EPDM - cellular rubber,
with stainless steel plate A2

50		

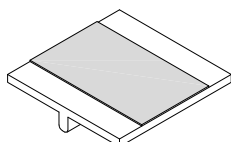

Z 912916

Sealing piece,
60 x 46 x 5 mm
EPDM - cellular rubber,
with stainless steel plate A2

	60	

104000300

Installation; refer to Processing Information

Façade series Trigon

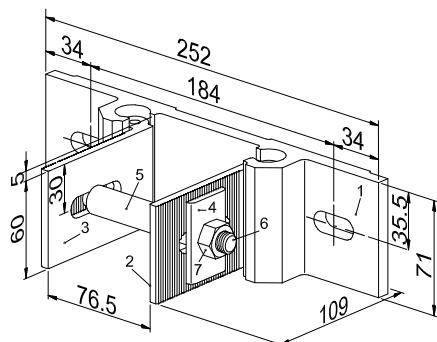

Short bracket Z 912745		
Pos.	Quantity	Denomination
1	1	Wall panel
2	1	Leg plate
3	1	Leg plate
4	2	Fixing plate
5	1	Sleeve $\varnothing 17.2 \times 2.3 - A2$
6	1	Hexagon screw DIN 931 M12 x 110 - A2 (self-locked)
7	1	Hexagon nut DIN 934 M12 x A2

50	60	
50 SG	60 SG	

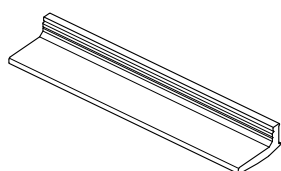

Glass support, length 100 mm	
Article number	Rebate width
Z 911809	16 mm
Z 911810	32 mm
Z 911811	42 mm
Z 911898	52 mm

50		

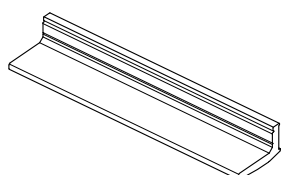

Glass support, length 100 mm	
Article number	Rebate width
Z 911909	16 mm
Z 911910	32 mm
Z 911911	42 mm
Z 911985	52 mm

	60	

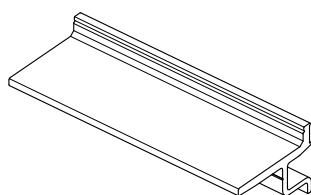

Glass support reinforced, length 100 mm	
Article number	Rebate width
Z 912727	32 mm
Z 912728	42 mm
Z 912729	52 mm

50		

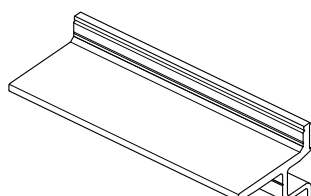

Glass support reinforced, length 100 mm	
Article number	Rebate width
Z 917053	42 mm
Z 917054	52 mm

	60	

105000400

Installation: refer to Processing Information

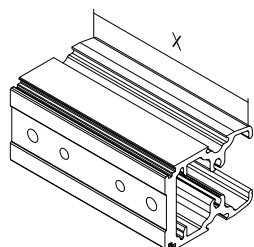

T-brackets		
Article number	suitable for transom profile	Dimension X
Z 918574	P 520248	39 mm
Z 918575	P 520234	62 mm
Z 918579	P 520235	89 mm
Z 918580	P 520236	112 mm
Z 918963	P 520353	122 mm
Z 918581	P 519358	138 mm
Z 918964	P 519354	152 mm
Z 918661	P 519356	180 mm
Z 918661	P 520229	180 mm

Façade series Trigon

50		
50 SG		

T-brackets		
Article number	suitable for transom profile	Dimension X
Z 918582	P 524164	39 mm
Z 918583	P 524113	62 mm
Z 918584	P 524114	86 mm
Z 918585	P 524115	112 mm
Z 918965	P 524122	119 mm
Z 918586	P 524165	138 mm
Z 918966	P 524123	152 mm
Z 918678	P 524117	159 mm
Z 918679	P 524118	179 mm
Z 918680	P 524119	203 mm

	60	
	60 SG	

Z 912865



Connector pin

50	60	
50 SG	60 SG	

Z 912604



Connector screw,
thread DIN EN ISO 1478 - St4.8 x 16-F,
Including EPDM washer with Torx drive
T20, Fixing the transom to the T-bracket

50		
50 SG		

Z 914198



Connector screw,
thread DIN EN ISO 1478 - St4.8 x 16-F,
Including EPDM washer with Torx drive
T20, Fixing the transom to the T-bracket

	60	
	60 SG	

Z 917133



Connector screw,
thread DIN EN ISO 1478 - St4.8 x 13-F
with Torx drive T20, fixing the T-bracket
to the mullion
without lock washer

50	60	
50 SG	60 SG	

Installation: refer to Processing Information

106000500

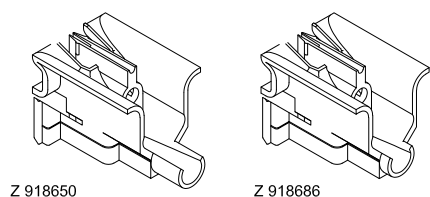

Z 918650

Z 918686

Shaped piece for field-by-field ventilation	
Article number	For outside glass
Z 918650	6 - 12 mm
Z 918686	6 mm

Façade series Trigon SG

50 SG		

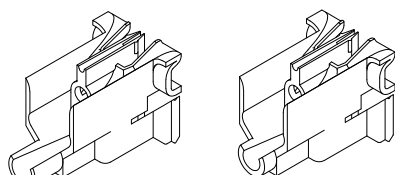

Z 918651

Z 918685

Shaped piece for field-by-field ventilation	
Article number	For outside glass
Z 918651	6 - 12 mm
Z 918685	6 mm

	60 SG	

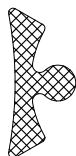

Z 914399

Sealing gasket,
made of PE, for gap dimension 20 mm
(Tolerance range + / - 1 mm)

50 SG	60 SG	



Z 918652

Shaped piece,
made of silicone,

50 SG	60 SG	

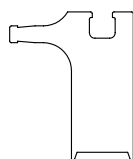

Z 918577

Single toggle,
made of aluminium,
Length: 35 mm

50 SG	60 SG	

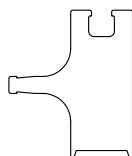

Z 918576

Single toggle,
made of aluminium,
Length: 35 mm

50 SG	60 SG	



Z 918588

Gasket for single Toggle,
made of silicone

50 SG	60 SG	

107000700

Installation: refer to Processing Information



Z 911944

Facade screw 25 mm,
for toggle fixing

50 SG	60 SG	



Z 911935

Facade screw 37,5 mm,
for toggle fixing

50 SG	60 SG	

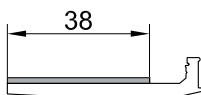

Z 997468

Glass support with silicone,
made of aluminium,
Length: 100 mm

50 SG		

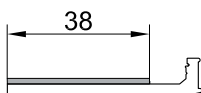

Z 997462

Glass support with silicone,
made of aluminium,
Length: 100 mm

50 SG		

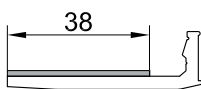

Z 997461

Glass support with silicone,
made of aluminium,
Length: 100 mm

	60 SG	

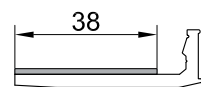

Z 997463

Glass support with silicone,
made of aluminium,
Length: 100 mm

	60 SG	

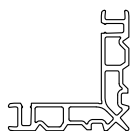

Z 918681

Corner bracket 4,8 mm
(from P 599343)

50 SG	60 SG	



Z 918560

Silicone pad for glass support 46 mm

50 SG	60 SG	

108000800

Installation: refer to Processing Information

Overview - Screws

Façade series Trigon

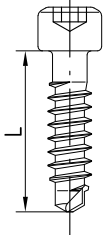
Art. No.	Dimension L	Type	Illustration
Z 911944	25 mm	Façade screw Torx T25	
Z 911934	30 mm		
Z 911935	37.5 mm		
Z 911936	46 mm		
Z 911938	56 mm		
Z 911897	66 mm		



Z 900235

Lens head - tapping screw 3,9 x 16 mm,
for fixing pressure plate
DIN 7981



Z 912668

Torx-screw 4,8 x 14 mm,
for fixing of t-bracket
DIN EN ISO 1478



Z 900656

Tapping screw 3,9 x 19 mm,
for fixing supplementary profile
DIN 7982



Z 907845

Tapping screw 3,9 x 32 mm,
for fixing supplementary profile
DIN 7982



Z 912717

Sealing material, grey, EPDM suitable,
processing temperature 5 - 40 °
Celsius PU = 310 ml in foil cartridge



Z 912718

Sealing material, black, EPDM suitable,
processing temperature 5 - 40 ° Celsius
PU = 310 ml in foil cartridge



Z 903941

EPDM - glue, black for sealing mitre joints on glazing
gaskets processing temperature 12°-40°C, durability
6 months PU = 200 g tube

PU = packing unit

109000900

Punching rack and punching tools

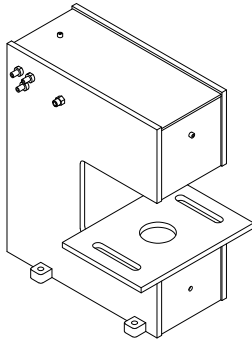

Z 992963

**Punching rack for punching tools
140 mm feed 25 mm**

HUECK "hydropneumatic punching machine", power transmission by means of pressure transformer, punching process triggered by foot valve, punching machine with foot valve, device for fast tool changing, 6 - 7 bar operating pressure required

Façade series Trigon

50	60	
50 SG	60 SG	

Punching tools for punching rack Z 992963

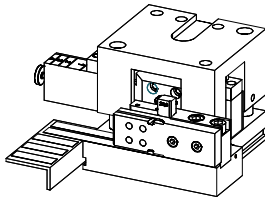

Z 994381

Punching tool for drill hole for fixing transom standard -, spring pin - and polygonal connection

50		
50 SG		

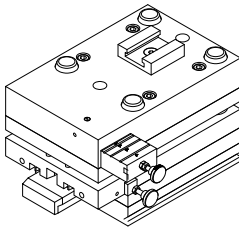

Z 996401

Punching tool for drill hole for fixing transom standard -, spring pin - and polygonal connection

	60	
	60 SG	

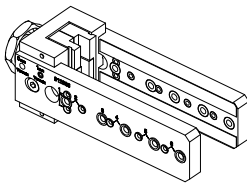

Z 912666

Drilling jig for T - brackets

50		
50 SG		

Z 912946

Drilling jig for T - brackets

	60	
	60 SG	

Z 912690

notching shears for removal the gasket fin of the internal glazing gaskets

50	60	
50 SG	60 SG	

141000100

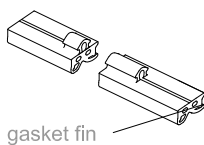

1 Preface

The present comments on processing and installation are to be used as instructions. Due to the diversity of the installation situations which may occur on site, only standard solutions are described.

The general indications concerning the processing of HUECK series as well as the characteristic data of material, regulations and standards for façades have to be observed.

1.1 General information on processing profile systems

Building profile ranges are to be manufactured and installed according to the regulations set forth in the technical terms of delivery.

They are intended for processing by specialised metal window manufacturers familiar with the general technical regulations, in particular in the field of metal, door, window and façade construction, who can be presumed to have knowledge of all the relevant DIN & British standards, regulations and guidelines.

The following instructions and recommendations correspond to the current state of the industry and are provided to the best of our knowledge.

If required, please contact design engineers.

The façade designs Trigon 50 and 60 are statically designed for accepting the horizontal wind force and vertical pane loads. However, they are not designed for accepting roof loads or any other forces acting on the façade from the building structure.

Make sure that the vapour pressure equalisation holes remain permanently functioning.

It is recommended that structural engineers be consulted, regarding proof of stability and determination of suitability, in particular in case of sloping façades and dome constructions.

1.2 Construction principle

Series Trigon is a façade construction designed as a warm curtain wall for vertical and angular areas. The façade may be constructed in different variants of construction and installation.

In case of this façade, the same profiles are used both as mullions and transoms.

1.3 Connection

The mullion-transom connection is carried out with variable offset from 0 mm to 1 mm.

- simple straight length of mullions and transoms - no notching
- a punching tool is used to punch the transoms cut into length on both sides
- the t-bracket holes are drilled into the mullions by means of a drilling jig
- insert transom housing gasket into the t-bracket
- position and screw the t-brackets
- slide in the transom and fix it with screws

Attention!

The present document contains comments on processing for the series

Trigon 50 / 50 SG and Trigon 60 / 60 SG.

As both series can be processed identically to a large extent, any deviations are indicated as follows:

Trigon 50 / 50 SG = article number without brackets

Trigon 60 / 60 SG = article number in brackets ()

Profile numbers, article numbers for accessories and measurements without marking apply to both series.

2.1 Mullion-transom installation

As a principle, mullions and transoms are fixed to the building structure in case of a mullion-transom installation.

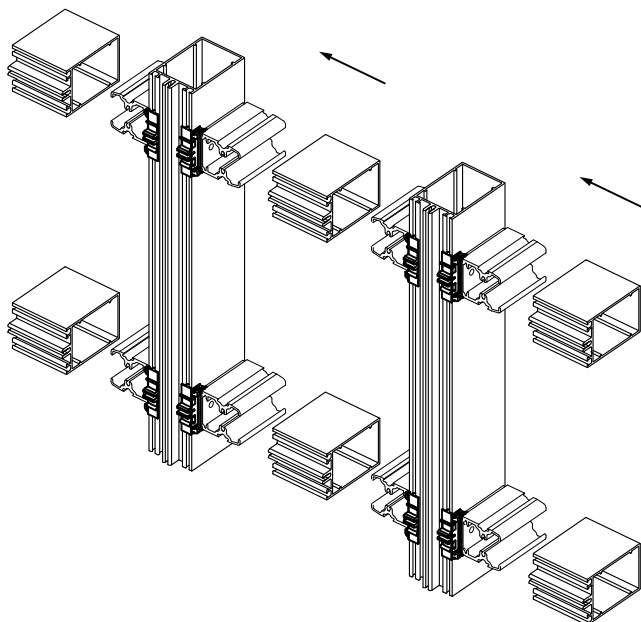

2.2 Unit-transom installation

Pre-fabricated units are fixed to the building structure and connected by means of transoms.

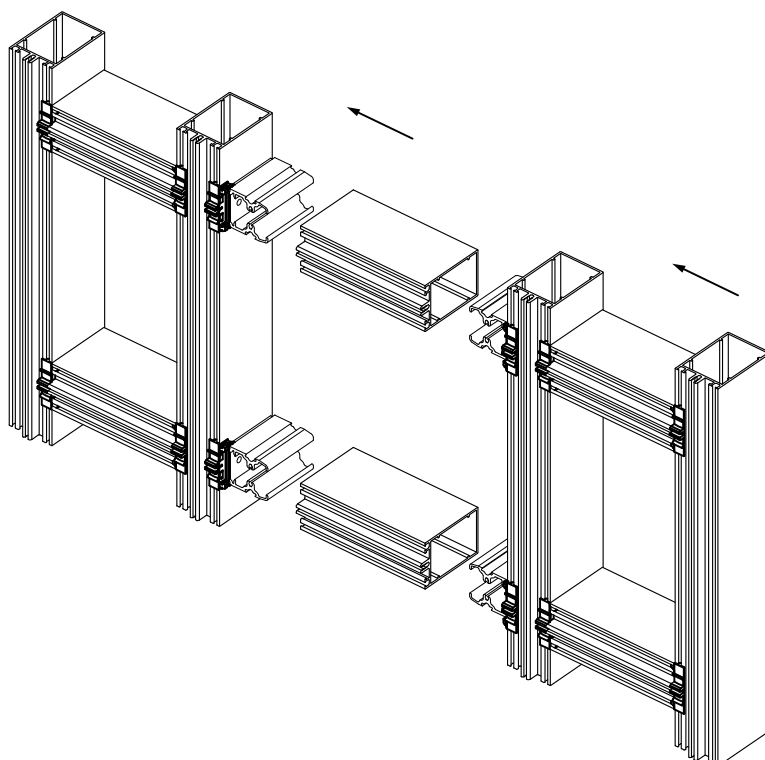

152000200

3.1 Spacer profile with single pressure plate glazing gasket

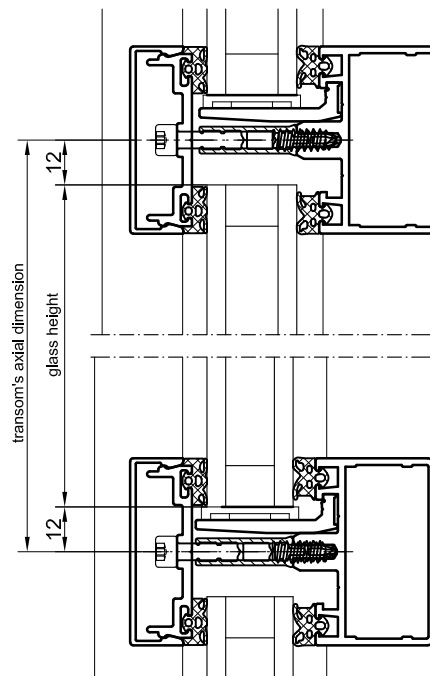
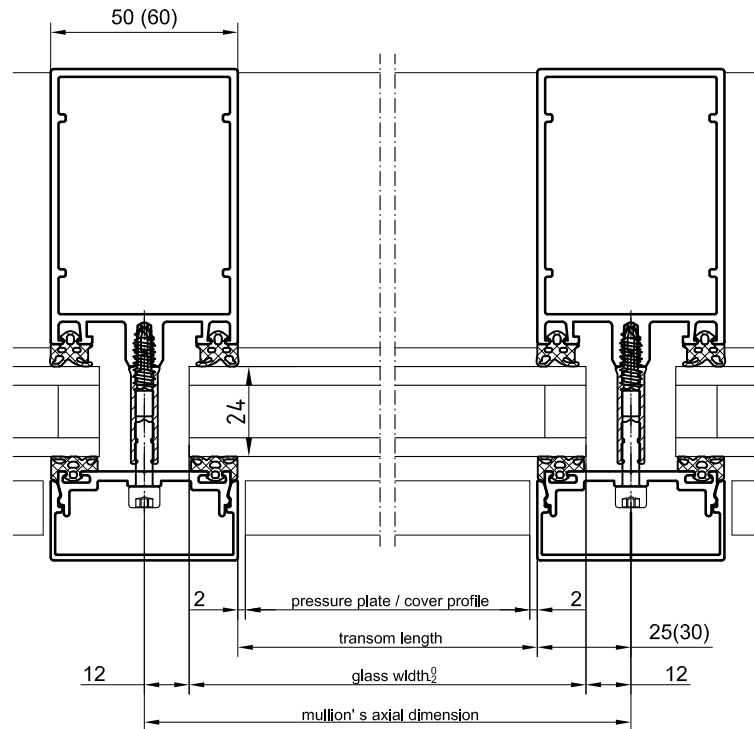

153000300 Cutting length: transom length = mullion's axial dimension - 50 mm (60 mm)
 transom pressure plate and cover profiles = mullion's axial dimension - 54 mm (64 mm)
 mullion pressure plate and cover profiles = mullion length
 glass dimension (mullion and transom) = mullion's axial dimension - 24 mm

4.1 Mullion drillings for standard fixing of transom / connector

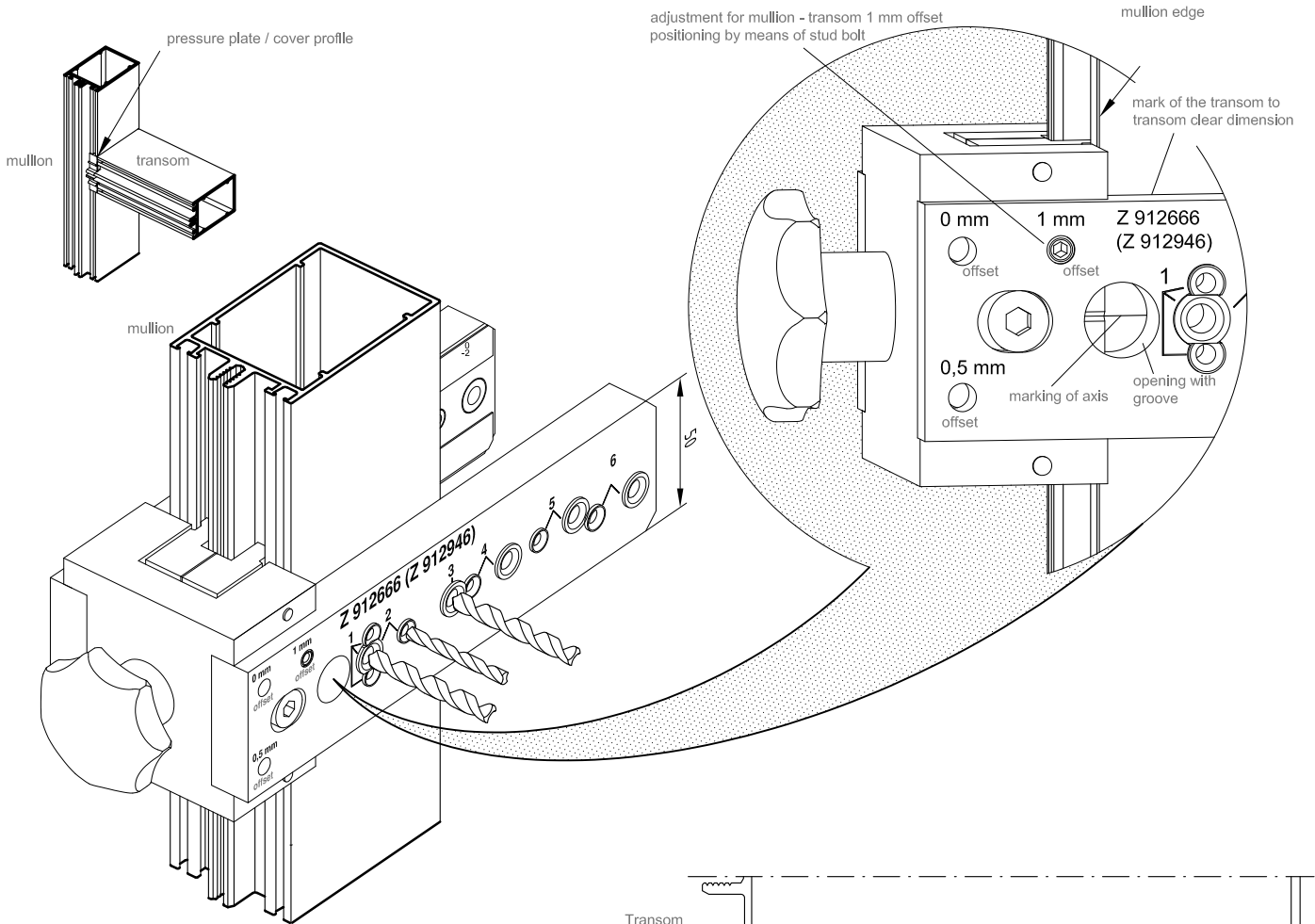

Standard adjustment for mullion - transom 1 mm offset

Table: Connector drill holes with 1 mm offset between mullion and transom

Trigon 50		Trigon 60		drilling scheme
transom profile	T-bracket	transom profile	T-bracket	
P 520248	Z 918574	P524164	Z918582	2
P 520234	Z 918575	P524113	Z918583	2 + 3
P 520235	Z 918579	P524114	Z918584	2 + 4
P 520236	Z 918580	P524115	Z918585	2 + 4
-	-	P524122	Z918965	2 + 4
P 520353	Z 918963	P524165	Z918586	2 + 5
P 519358	Z 918581	P 524123	Z918966	2 + 5
P 519354	Z 918964	P 524117	Z 918678	2 + 5
P 519356	Z 918661	P 524118	Z 918679	2 + 5
P 520229	Z 918661	P 524119	Z 918680	2 + 5

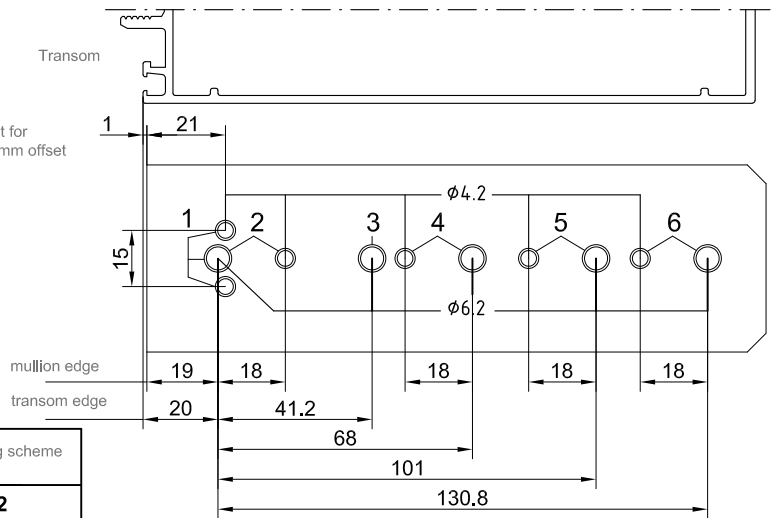

4.2 Drillings for fixing of connector without offset

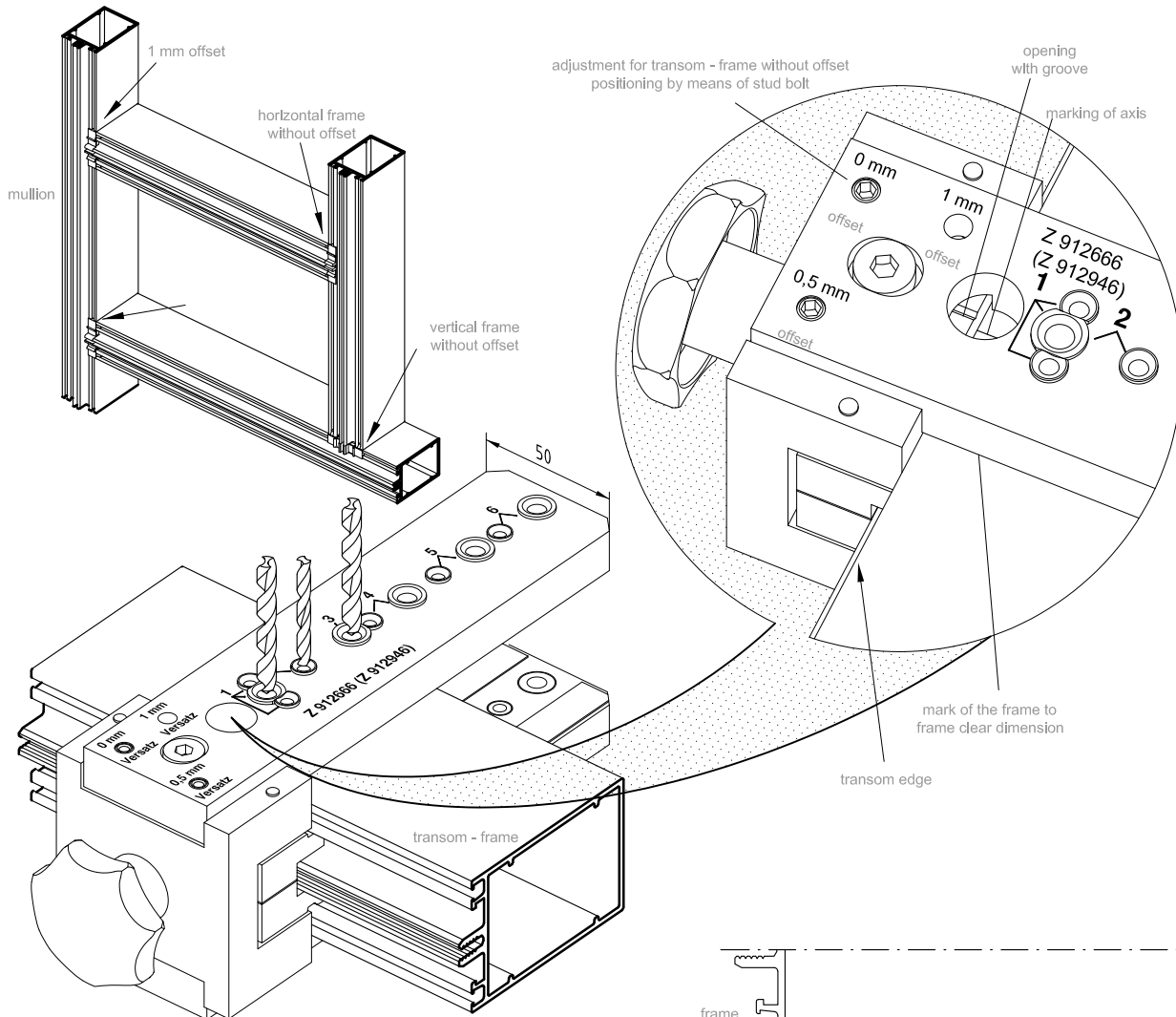
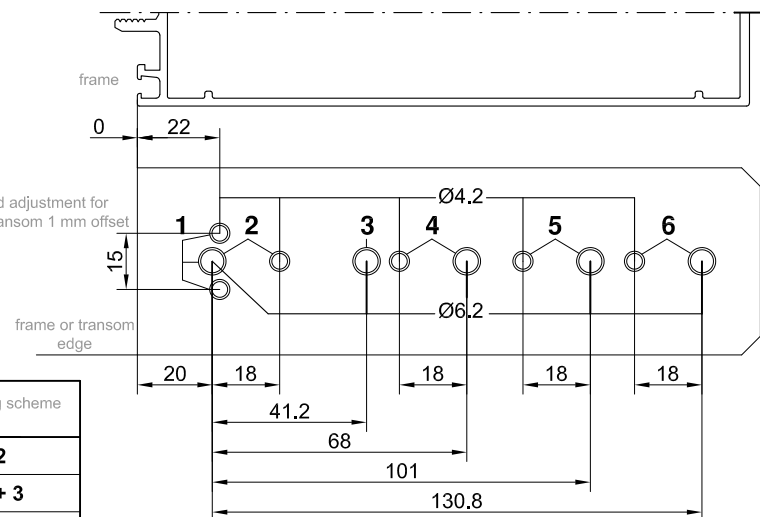

Table: Connector drill holes with 0 mm offset between mullion and transom

Trigon 50		Trigon 60		drilling scheme
transom profile	T -bracket	transom profile	T -bracket	
P 520248	Z 918574	P524164	Z918582	2
P 520234	Z 918575	P524113	Z918583	2 + 3
P 520235	Z 918579	P524114	Z918584	2 + 4
P 520236	Z 918580	P524115	Z918585	2 + 4
-	-	P524122	Z918965	2 + 4
P 520353	Z 918963	P524165	Z918586	2 + 5
P 519358	Z 918581	P 524123	Z918966	2 + 5
P 519354	Z 918964	P 524117	Z 918678	2 + 5
P 519356	Z 918661	P 524118	Z 918679	2 + 5
P 520229	Z 918661	P 524119	Z 918680	2 + 5



156006500

Trigon 50	
transom profile	punching tool
P 520248	Z 994381
P 520234	
P 520235	
P 520236	
P 520353	
P 519358	
P 519354	
P 519356	
P 520229	

4.3 Standard- , Trigon 50 with punching tool Z 994381

For the standard punching scheme, the fixing holes $\varnothing 5.5$ and the notch for the transom housing gasket are punched in one go by means of punching tool Z 994381.

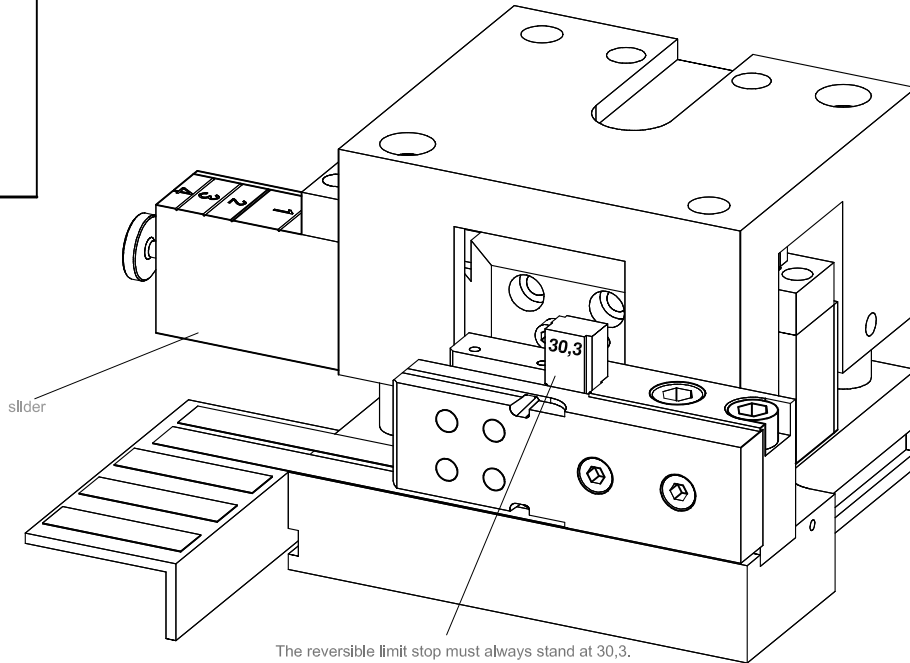

Slider calibration:

3

Milling scheme for standard connection

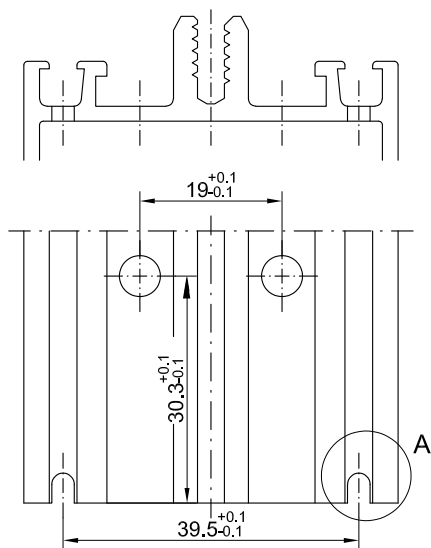

Detail A, 2:1

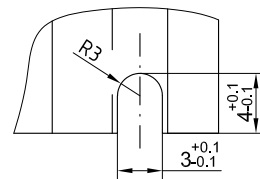

156000600

Trigon 60	
transom profile	punching tool
P 524164	Z 994401
P 524113	
P 524114	
P 524115	
P 524122	
P 524165	
P 524123	
P 524117	
P 524118	
P 524119	

4.4 Standard-, Trigon 60 with punching tool Z 996401

For the standard punching scheme, the fixing holes $\varnothing 5.5$ and the notch for the transom housing gasket are punched in one go by means of punching tool Z 996401.

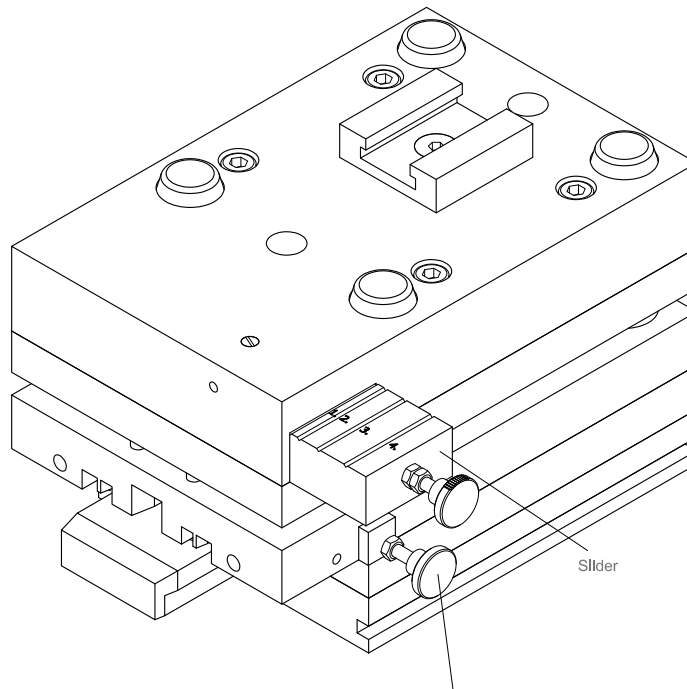

The reversible limit stop must always stand at 30,3.
Limit stop 29,8 is only relevant for the admission of stretch.

Slider calibration:

①

Drilling scheme for standard and polygonal connection

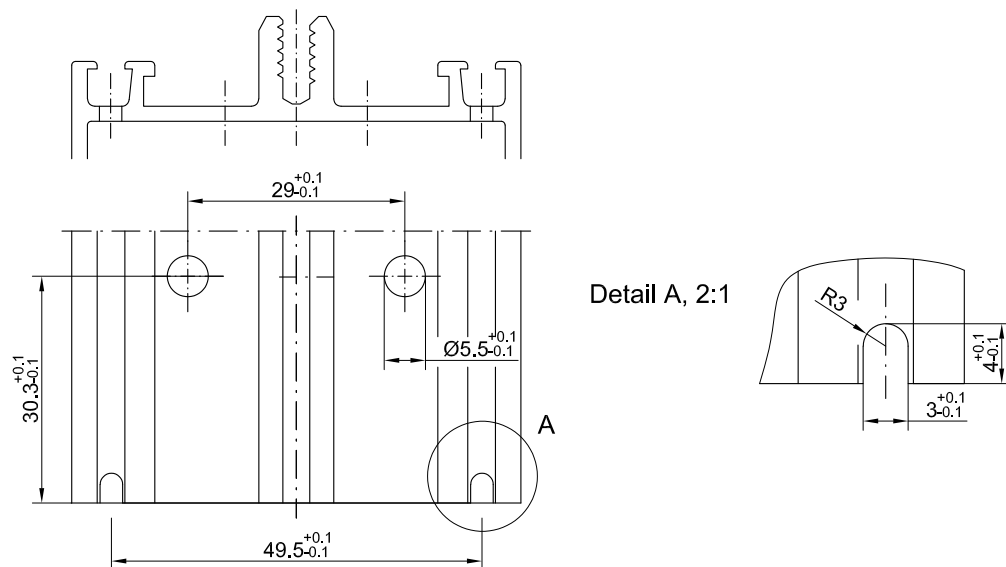

157000700

4.5 Transom length to accommodate 1 mm expansion

Cutting measure:

Transom length = mullion's axial dimension - 51 mm (-61 mm)

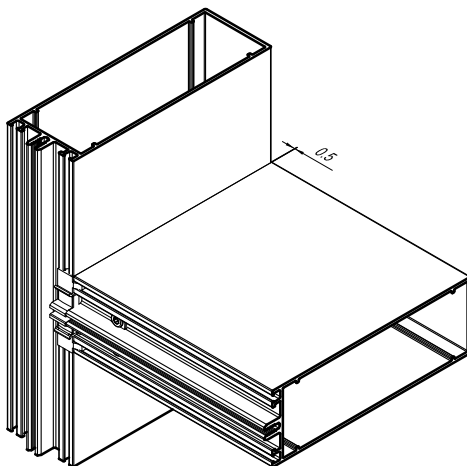

The following cut is necessary to enable the expansion:

Slider calibration press cut :

Z 994381 (3) (Z 996401 (1))

Milling scheme for standard connection

The reversible limit stop must stand at 29.8.

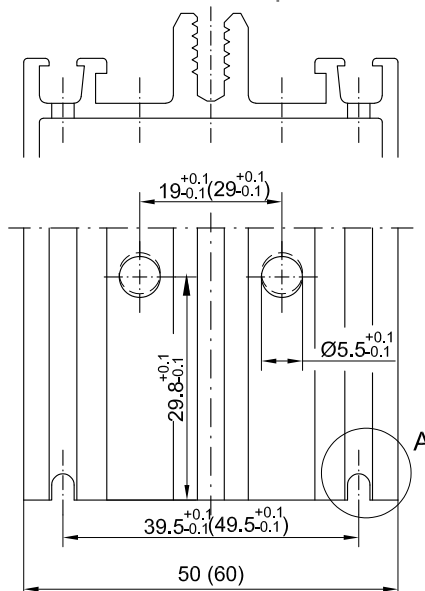

Detail A, 2:1

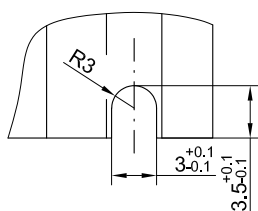

158000800

4.6 Assembly

The connection is made with appropriate T-joints and transom housing gaskets.
 Order of assembly: push transom housing gasket into the connector.
 then fix it to the mullion with the connector.

4.6.1 Connector assembly for transom profiles

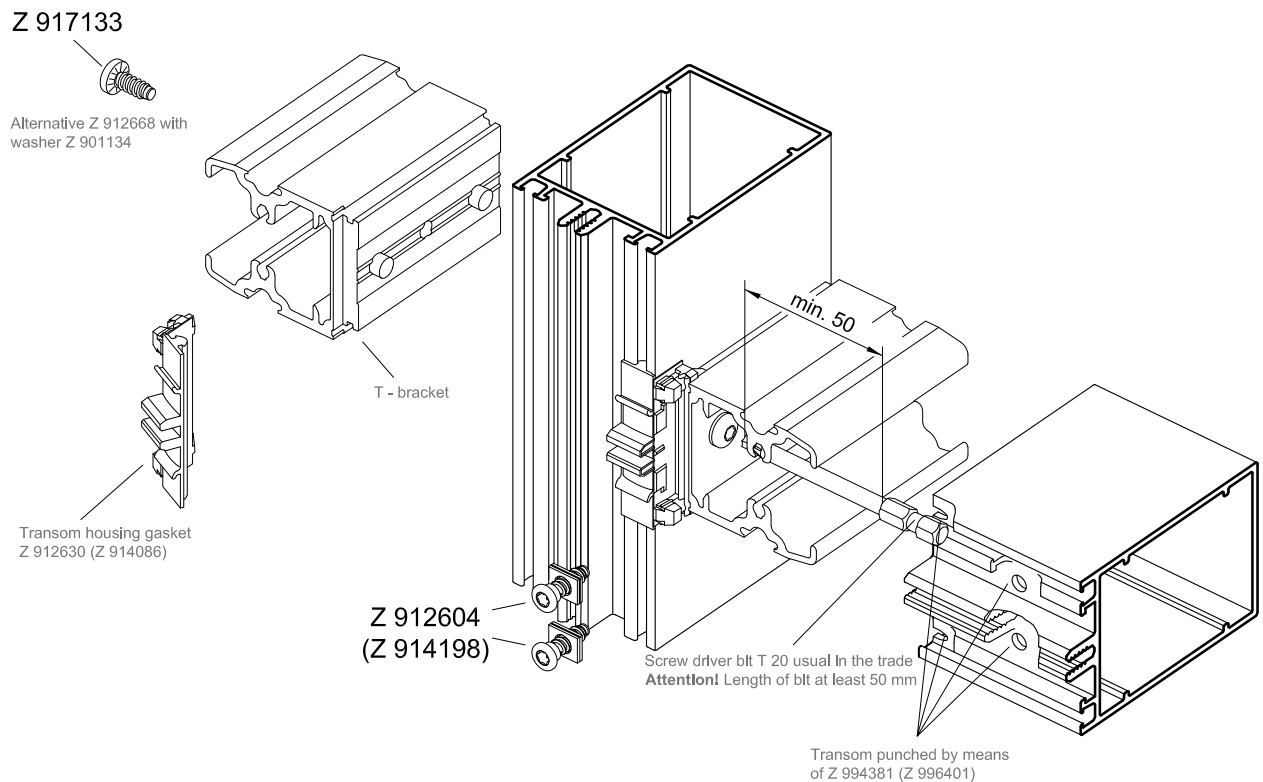

T-bracket - table Trigon 50			
transom profile	T-bracket	drilling jig	punching tool
P 520248	Z 918574	Z 912666	Z 994381
P 520234	Z 918575		
P 520235	Z 918579		
P 520236	Z 918580		
P 520353	Z 918963		
P 519358	Z 918581		
P 519354	Z 918964		
P 519356	Z 918661		
P 520229	Z 918661		

T-bracket - table Trigon 60			
transom profile	T-bracket	drilling jig	punching tool
P 524164	Z 918582	Z 912946	Z 994401
P 524113	Z 918583		
P 524114	Z 918584		
P 524115	Z 918585		
P 524122	Z 918965		
P 524165	Z 918586		
P 524123	Z 918966		
P 524117	Z 918678		
P 524118	Z 918679		
P 524119	Z 918680		

159000900

Supplementary profiles are to be cut into length according to the actual size. The sill of the supplementary profiles has to be notched in accordance with the detail below so that they fit over the transom housing gasket.

Attention!

Make sure the glass supports are hung before fixing the supplementary profiles!

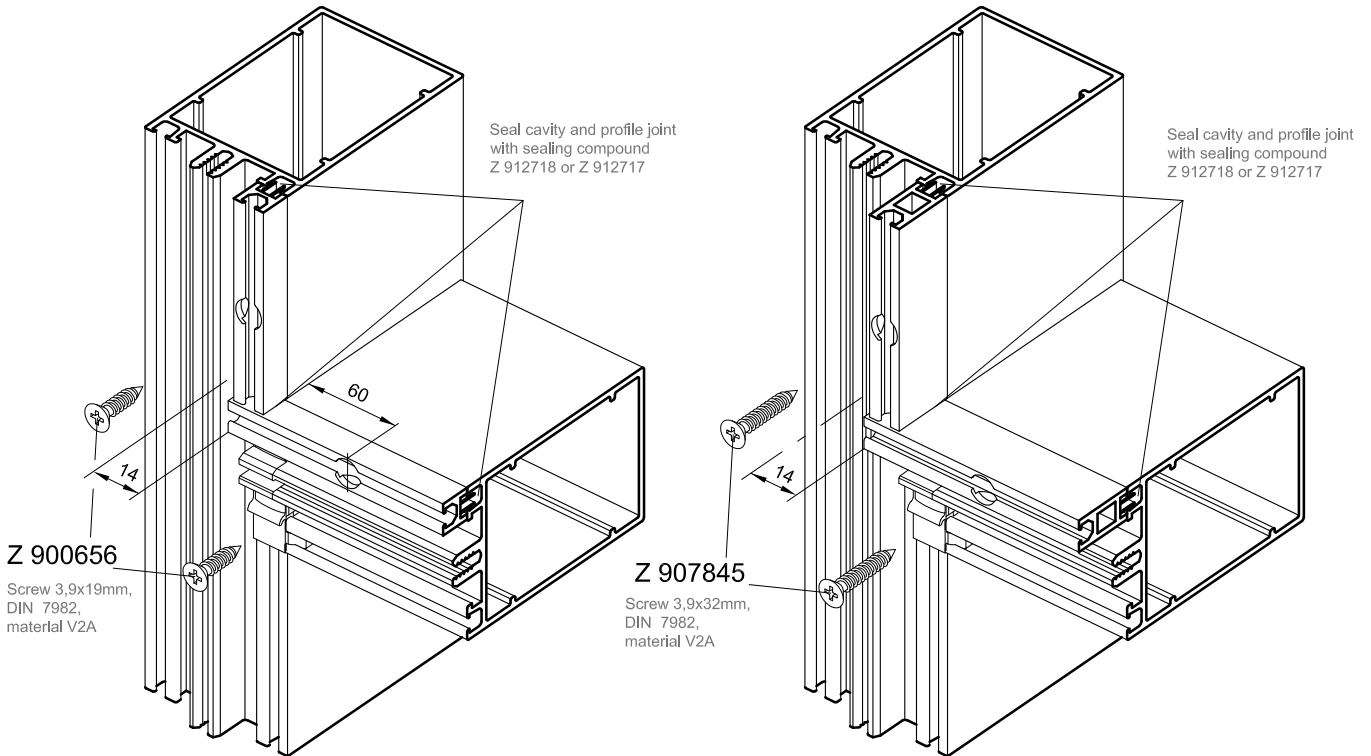

Cutting measure: supplementary profile in mullion = transom's axial dimension - 50 mm (60 mm)
 supplementary profile in transom = mullion's axial dimension - 28 mm (38 mm)

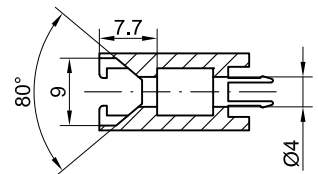

Supplementary profile
 P 419900 mill off snap-in feet

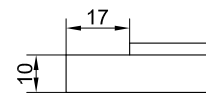

Supplementary profile
 P 519901 mill off snap-in feet

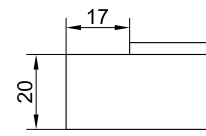

160001000

In order to guarantee that the sealing is weatherproof, the gasket installation has to be performed as indicated. The mullion gaskets are treated with sealing compound as shown.

Attention!

All joint and cutting edges have to be dry and free from grease and dust.

6.1 Glazing gaskets for use with spacer profiles

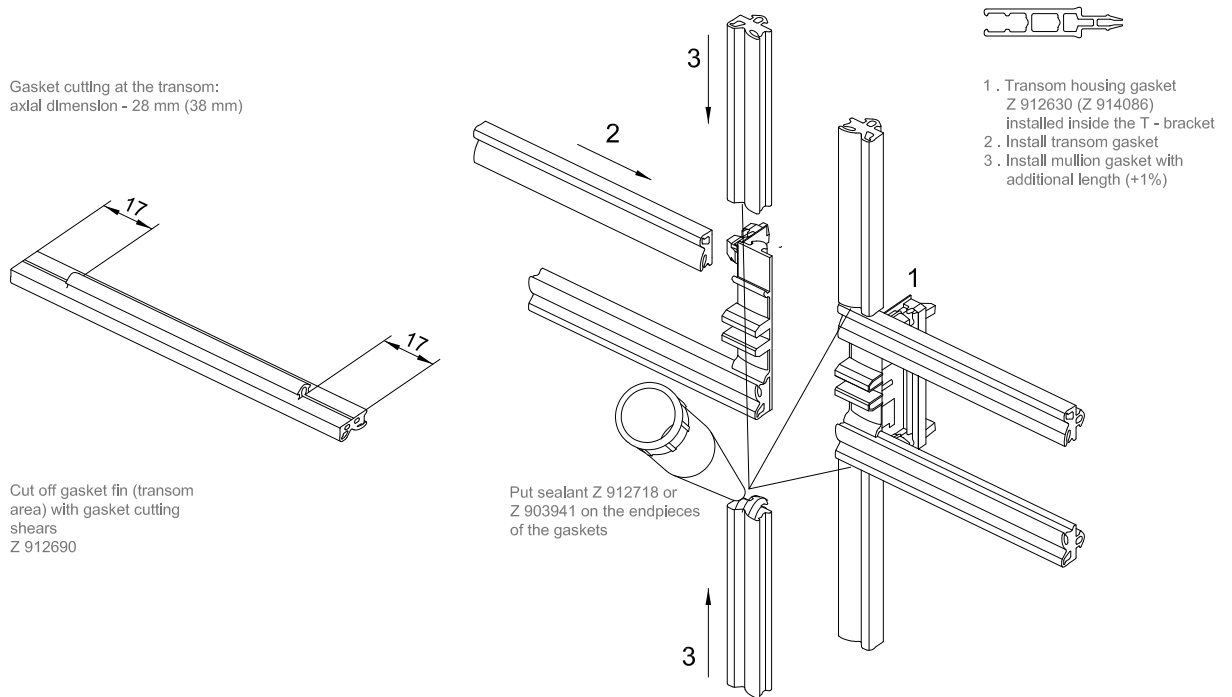

161001100

7.1 Pressure plate profile with single pressure plate glazing gasket (mullion)

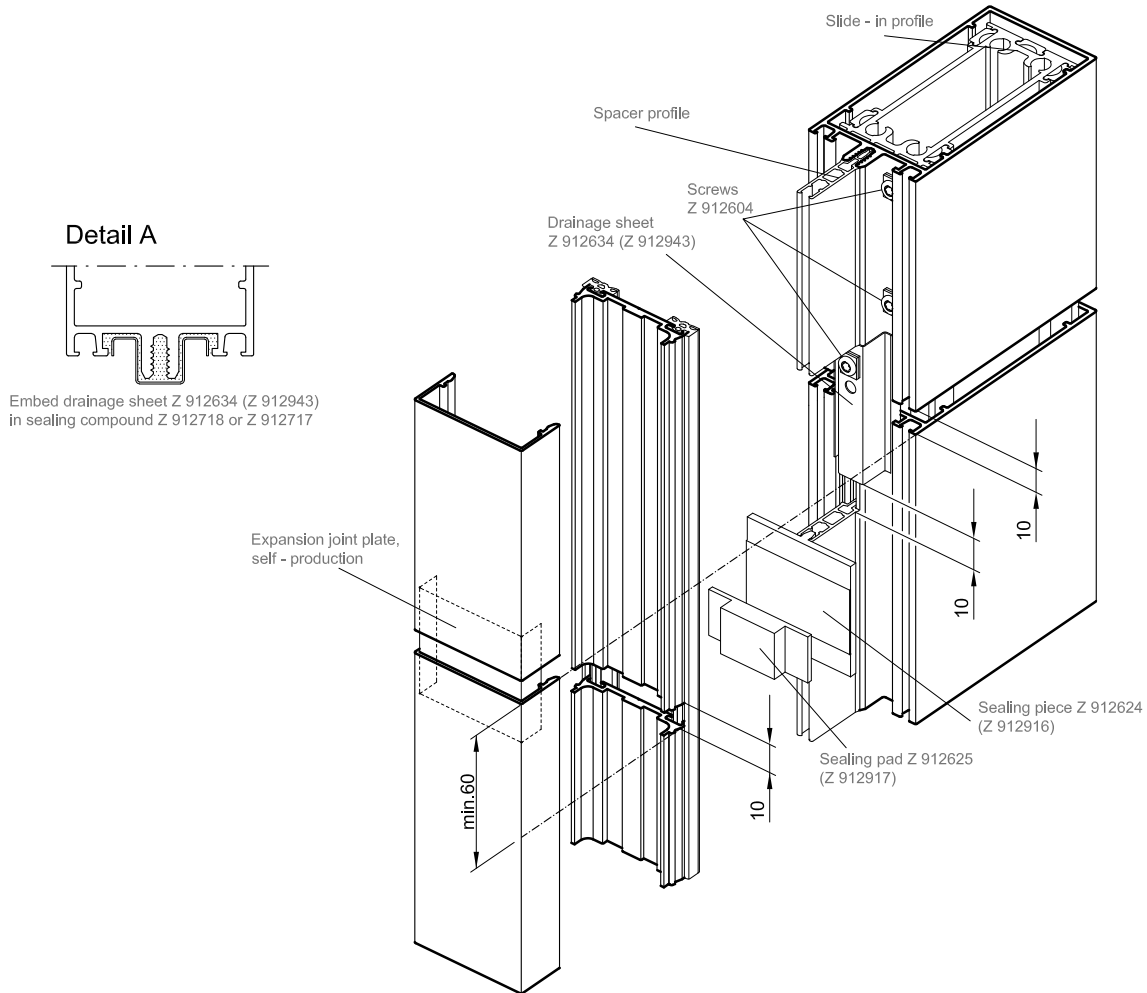

Expansion joint plate

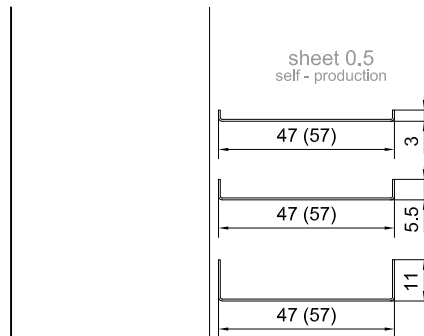

8.1 Processing the spacer profiles

The transom spacer profiles are cut according to the cutting length, and notched at each end as shown below.

If reinforced glass supports are used, the spacer profiles are fitted between.

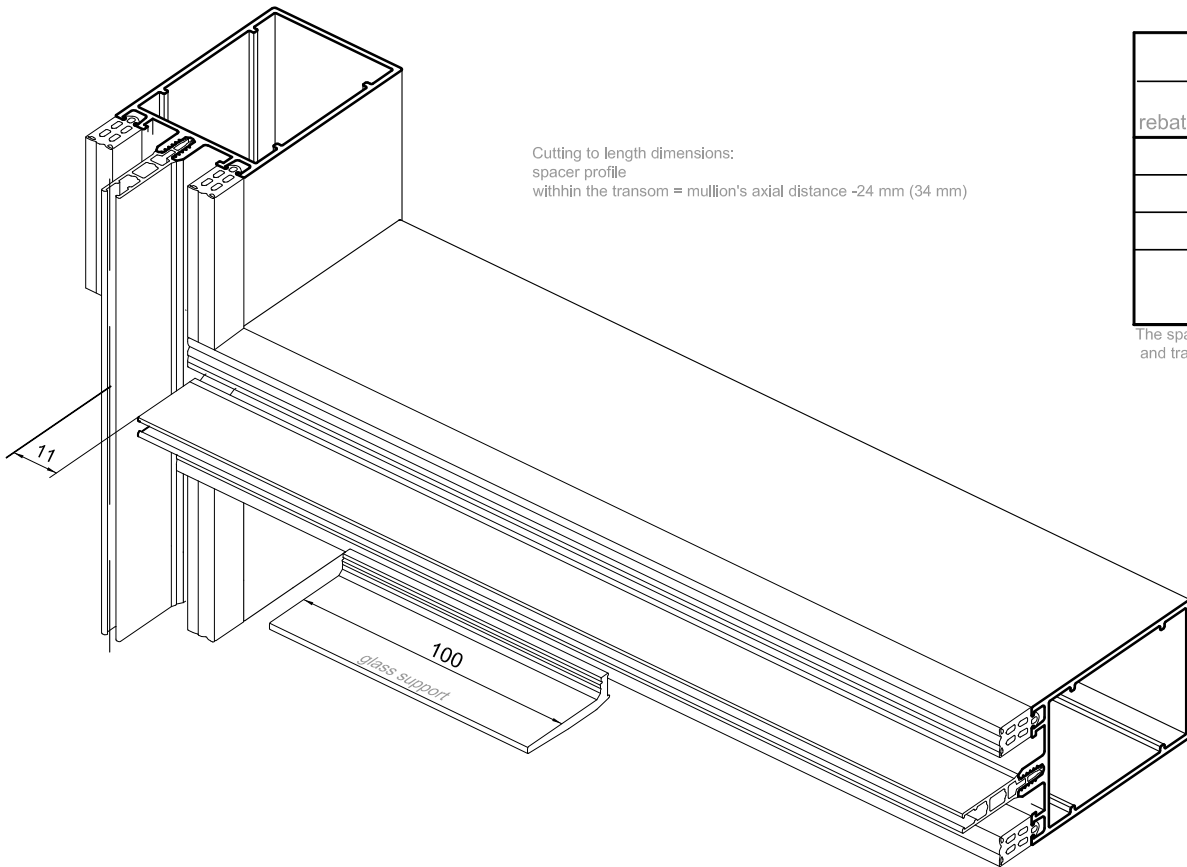

Cutting to length dimensions:
spacer profile
within the transom = mullion's axial distance -24 mm (34 mm)

Spacer profile

Trigon 50 / 60	
rebate width	spacer profile
16	Z 910064
32	Z 910066
42	Z 910068
52	Z 910064
	Z 910068

The spacer profile is identical for mullion and transom

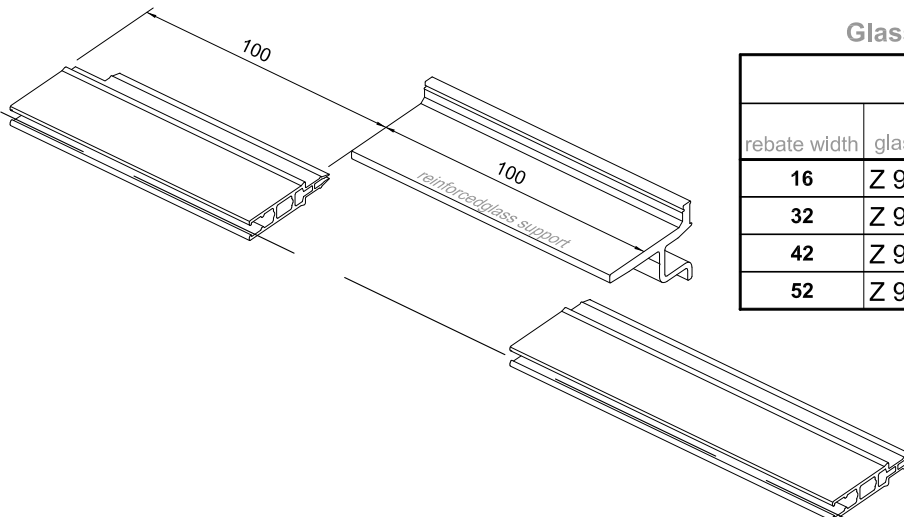

Glass support

rebate width	Trigon 50		Trigon 60	
	glass support	reinforced glass support	glass support	reinforced glass support
16	Z 911809	-	Z 911909	-
32	Z 911810	Z 912727	Z 911910	-
42	Z 911811	Z 912728	Z 911911	Z 917053
52	Z 911898	Z 912729	Z 911985	Z 917054

163001300
Reinforced glass supports are used for transmitting glass weight.
Spacer profiles are cut in between.

Attention!
Choose setting blocks in such a way as to ensure there is sufficient space between the glass or insert element and the glass retainer of the field above in order to avoid damaging the insert element.

Notch spacer profiles with gasket cutting shears Z 912690

At connection:

Mullion-transom

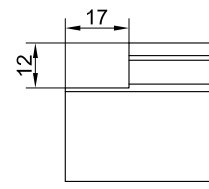

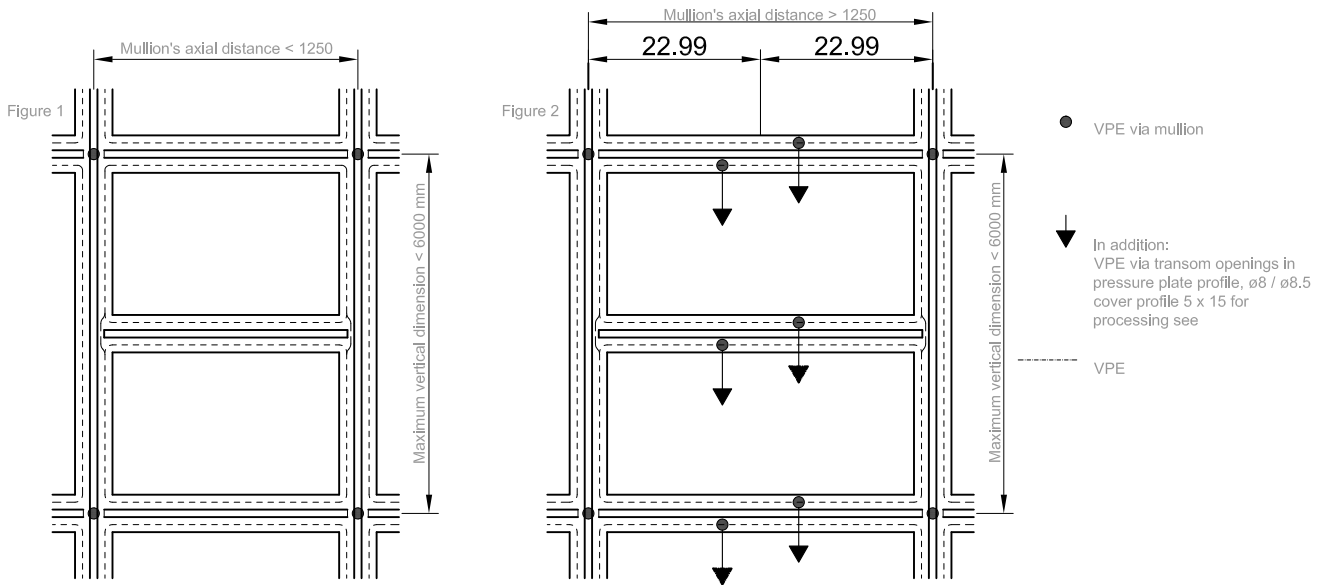

9.1 Supplementary vapour pressure equalization via transom cover cap and pressure plate profiles as well as spacer and insulating profiles

The dimensions shown in figure 2 are to be carried out if axial distance between mullions exceeds 1250 mm. Insulating profiles as well as pressure plate and cover profiles are to be processed as shown. The holes are offset by 50 mm and the drainage slot 5 x 15 is positioned centrally below them.

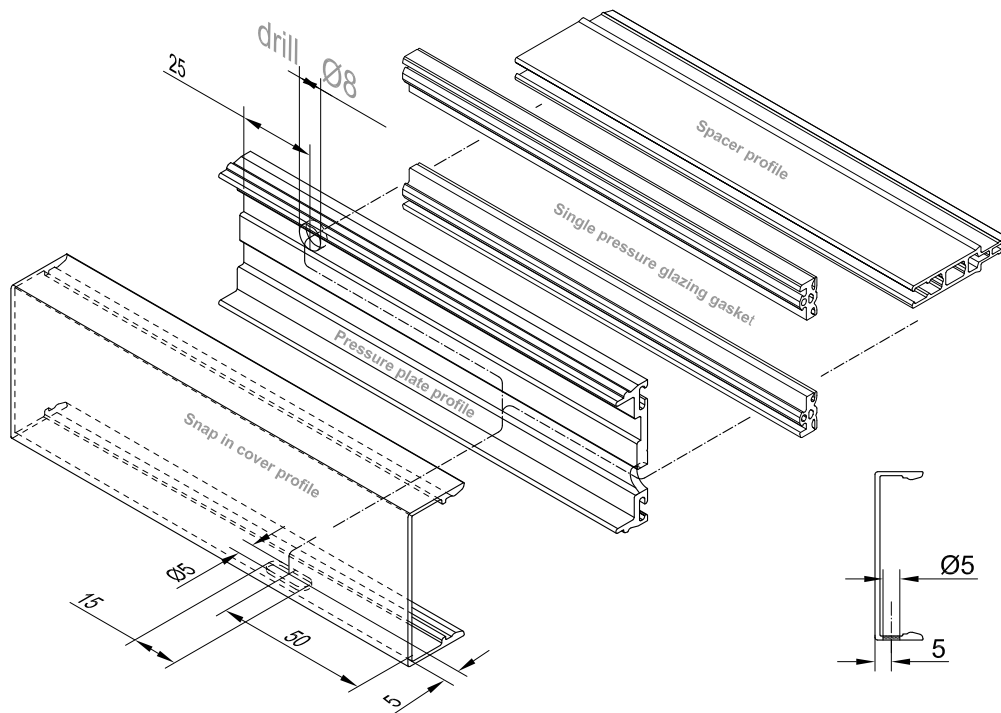

9.2 Vapour pressure equalization in case of pressure plate glazing gasket and spacer profiles

For axial dimensions of more than 1250 mm, holes are drilled into the pressure plate glazing gasket and the pressure plate profile in the transom area (as described in 9.1). In case of VPE via mullions, no holes in the pressure plate profile are required.

1) Suggestion for VPE using a shaped piece at the façade's head and sill. The shaped piece at the area sill to be optional.

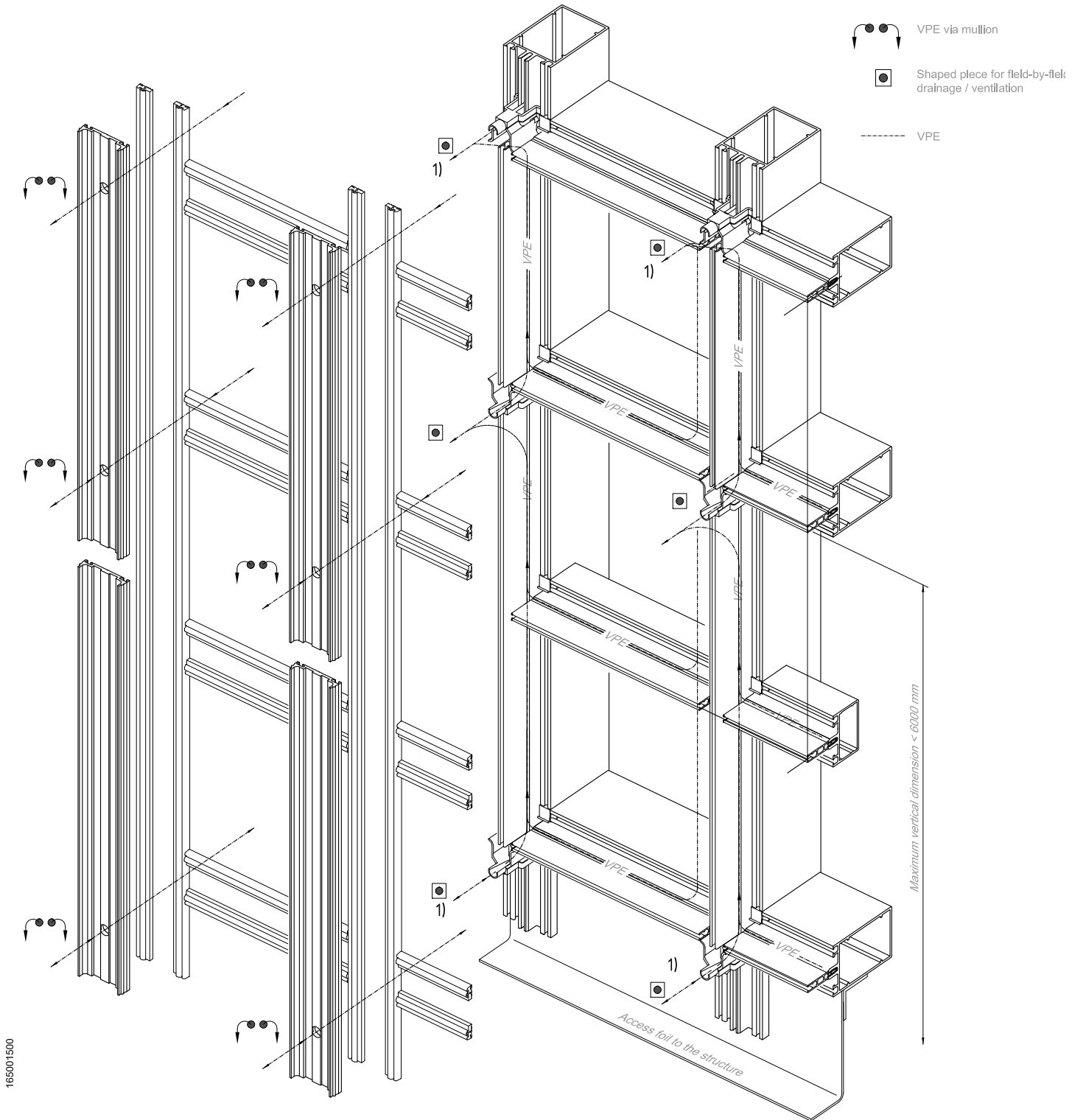

10.1 Individual pressure plate glazing gasket including sealing piece and sealing pad

If required, a construction including a drainage gap ($< 10 \text{ mm}$) as shown, is possible without changes to the installation. In any case, the sealing pad is positioned between the transom's pressure plate glazing gaskets. The mullion pressure plate glazing gaskets are continuous. The transom pressure plate glazing gaskets are installed with oversize along the pressure plate profile at the butt joint.

Attention!

In the roof area to insert is in principle butyl tape!

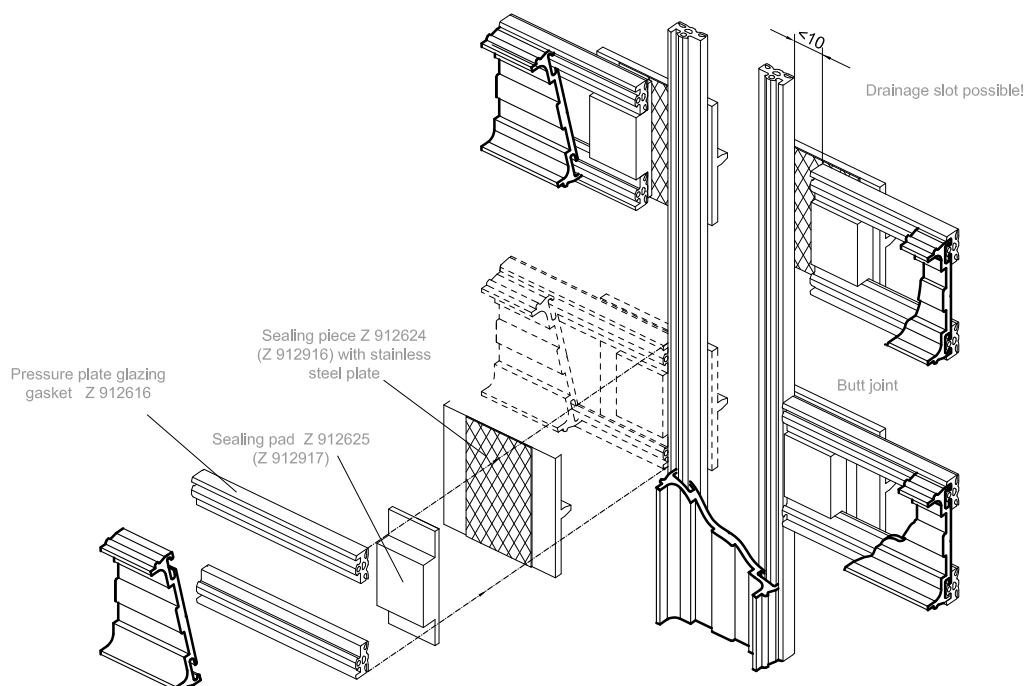

The pressure plate profile is to be fixed at no more than 255 mm centres, and no more than 45 - 62.5 mm from each end. At a corner and in the polygonal area fixing positions should be determined by calculation according to static requirements.

11.1 Pressure plate profile with snap-in cover profiles

In order to achieve a uniform distribution of the pressure on the sealing piece and to avoid damage to the sealing piece, the pressure plate profile is screwed directly adjacent to the sealing piece. The screws for the pressure plate profile are to be tightened to 4.5 Nm (torque). If necessary, the drainage shoe for field-by-field ventilation is used. This requires a $\varnothing 10$ mm hole through the pressure plate profile.

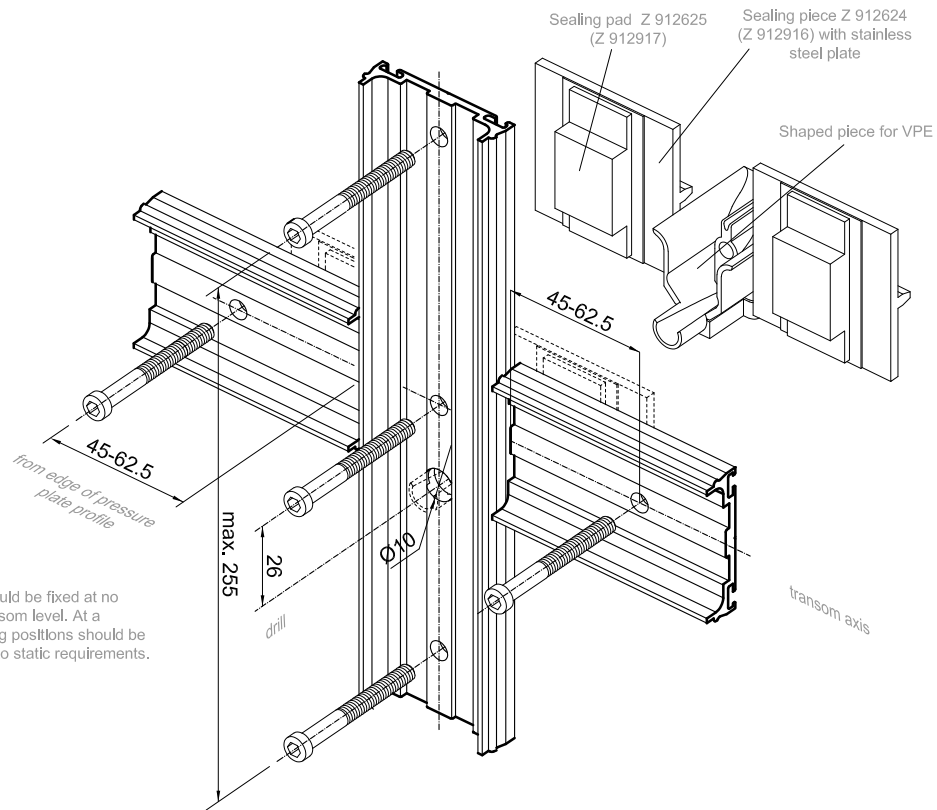

Ideally the mullion pressure plate should be fixed at no more than 80 mm away from the transom level. At a corner and in the polygonal area fixing positions should be determined by calculation according to static requirements.

11.2 Longitudinal joint pressure plate profile

Pressure plate profile with single pressure plate glazing gasket

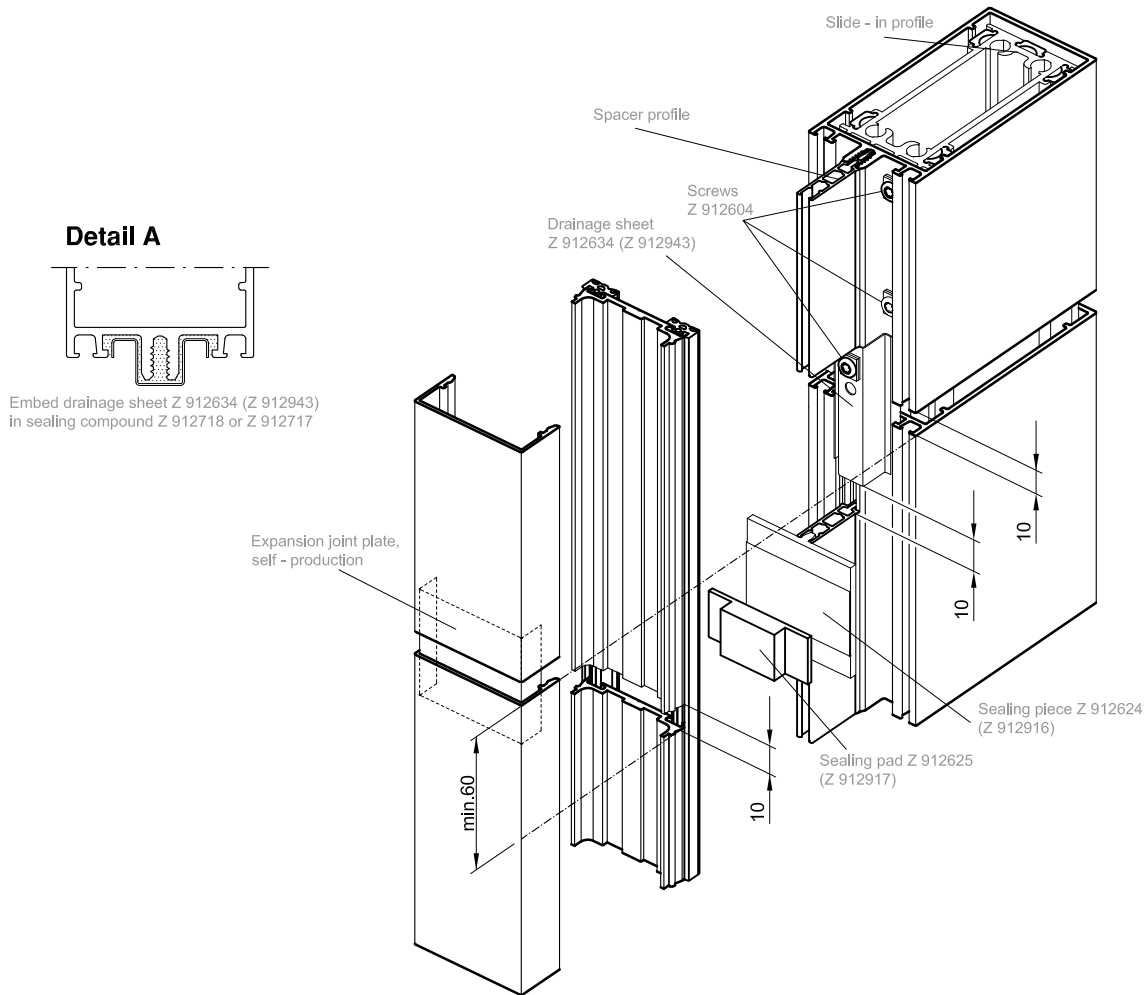

Expansion joint plate

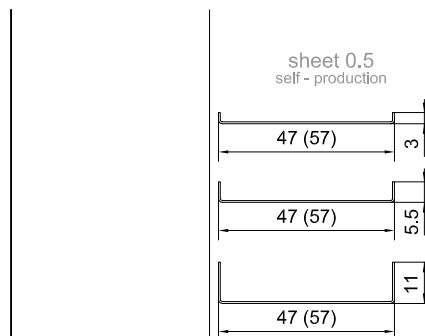

Fix the vertical cover cap profiles for each storey and / or each cut length in the upper transom area (concealed) on both sides by means of a self-tapping screw Z 900235 St 3.9 x 16 mm.

Attention!
Drill holes in the pressure plate profile and the snap-on cover cap profile at same time. Standard practice is that the mullion caps are deeper than the transom caps.

12.1 Safety fixing for snap-in cover profiles

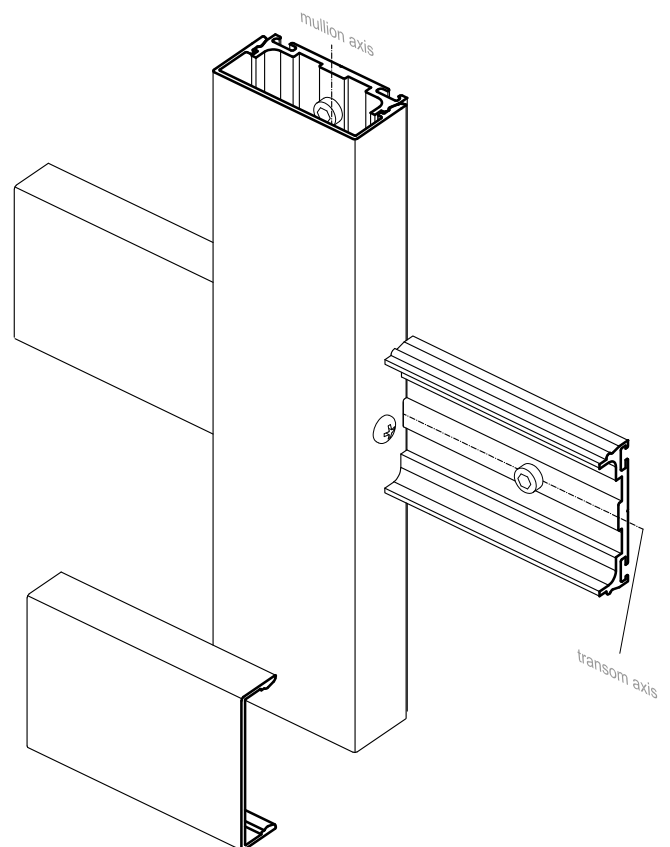
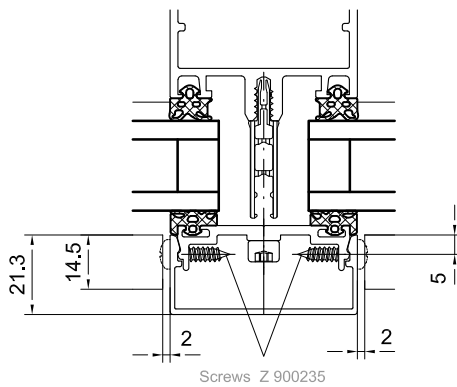

14.1 Processing spacer- and insulating profile

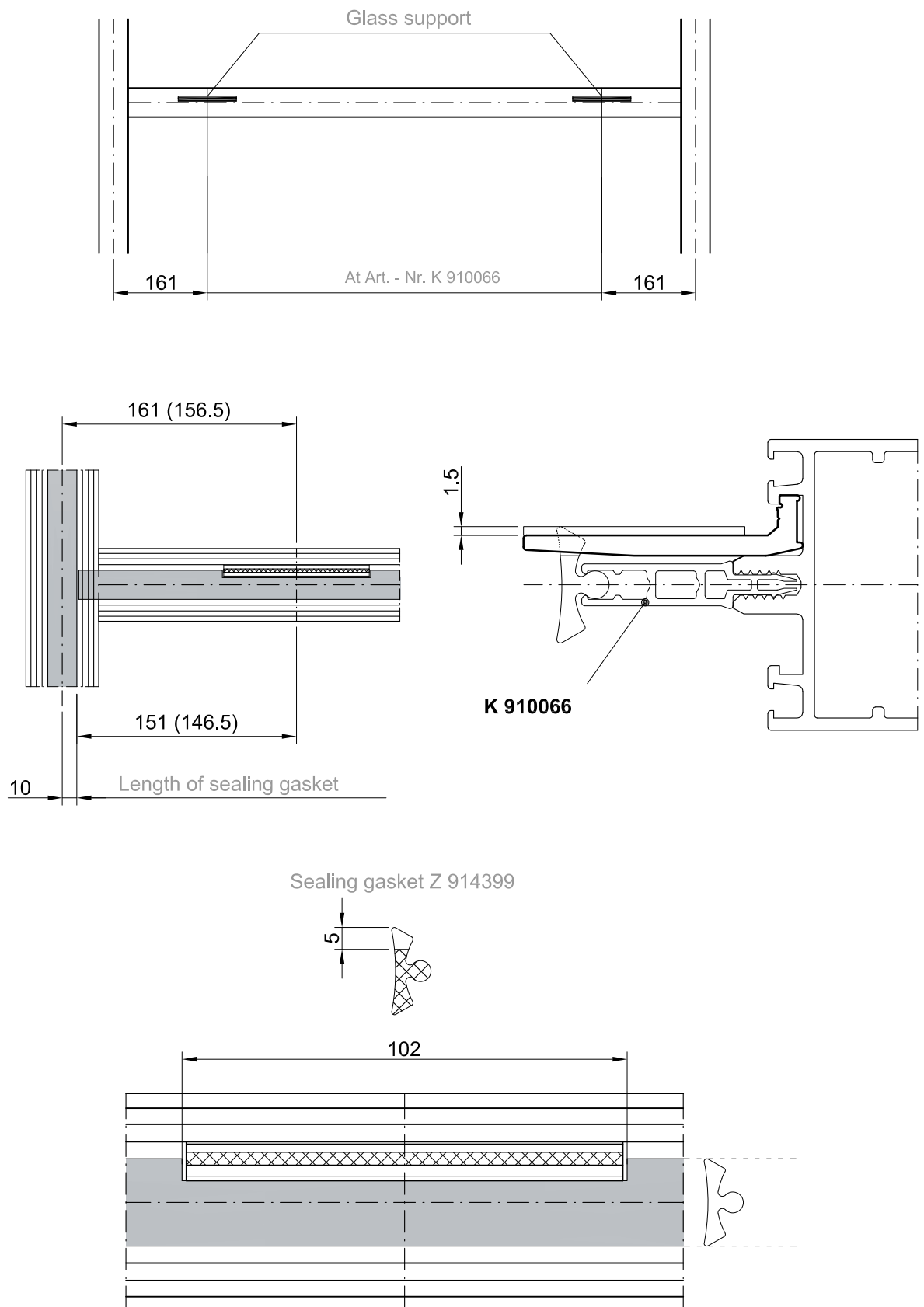

171002100

14.2 Adjustment of glass

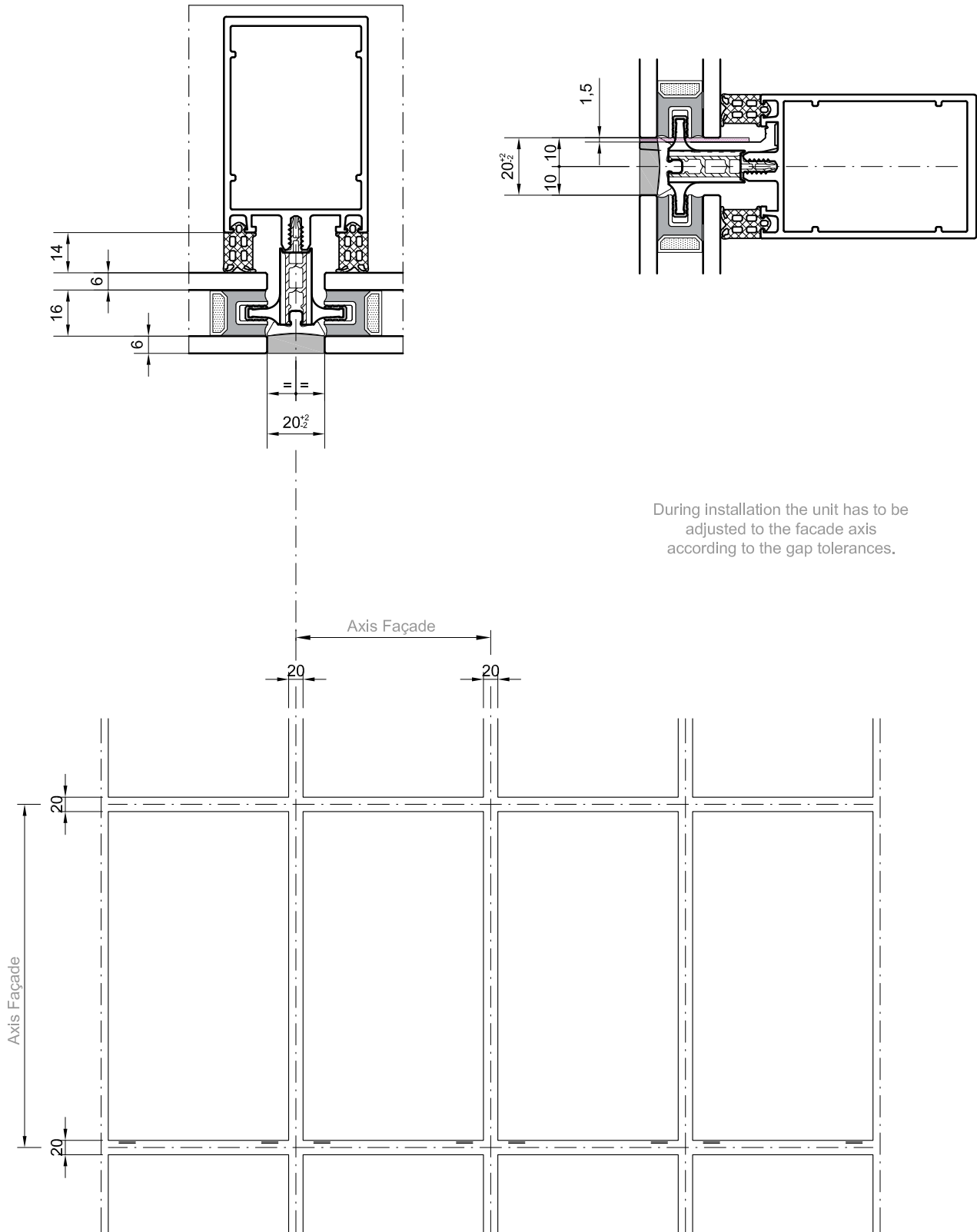

During installation the unit has to be adjusted to the façade axis according to the gap tolerances.

15.1 Vapour pressure equalisation

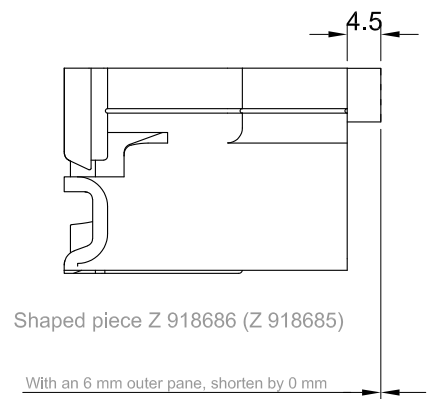
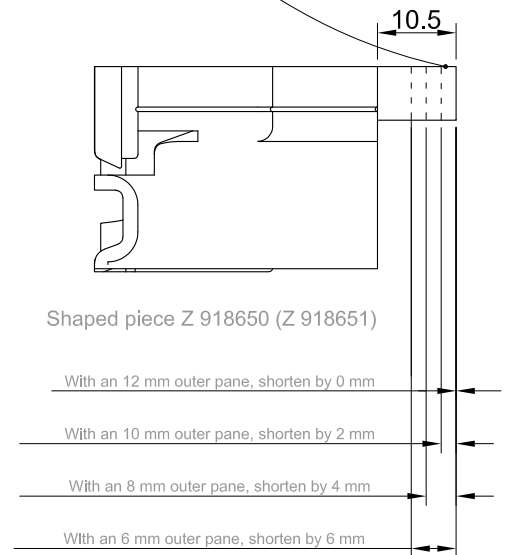
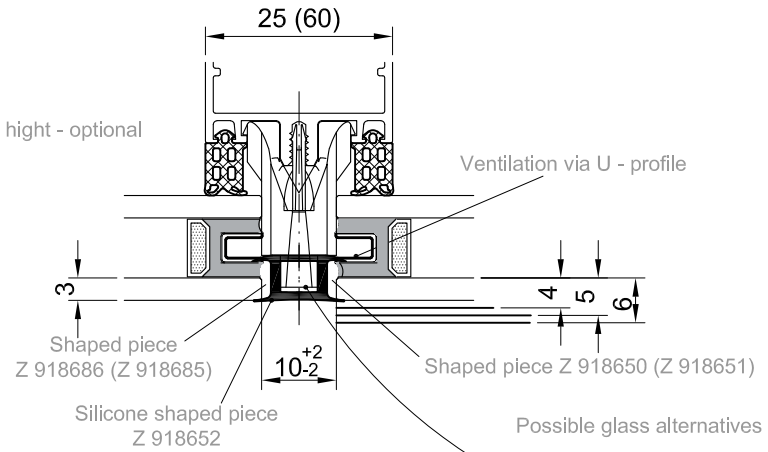
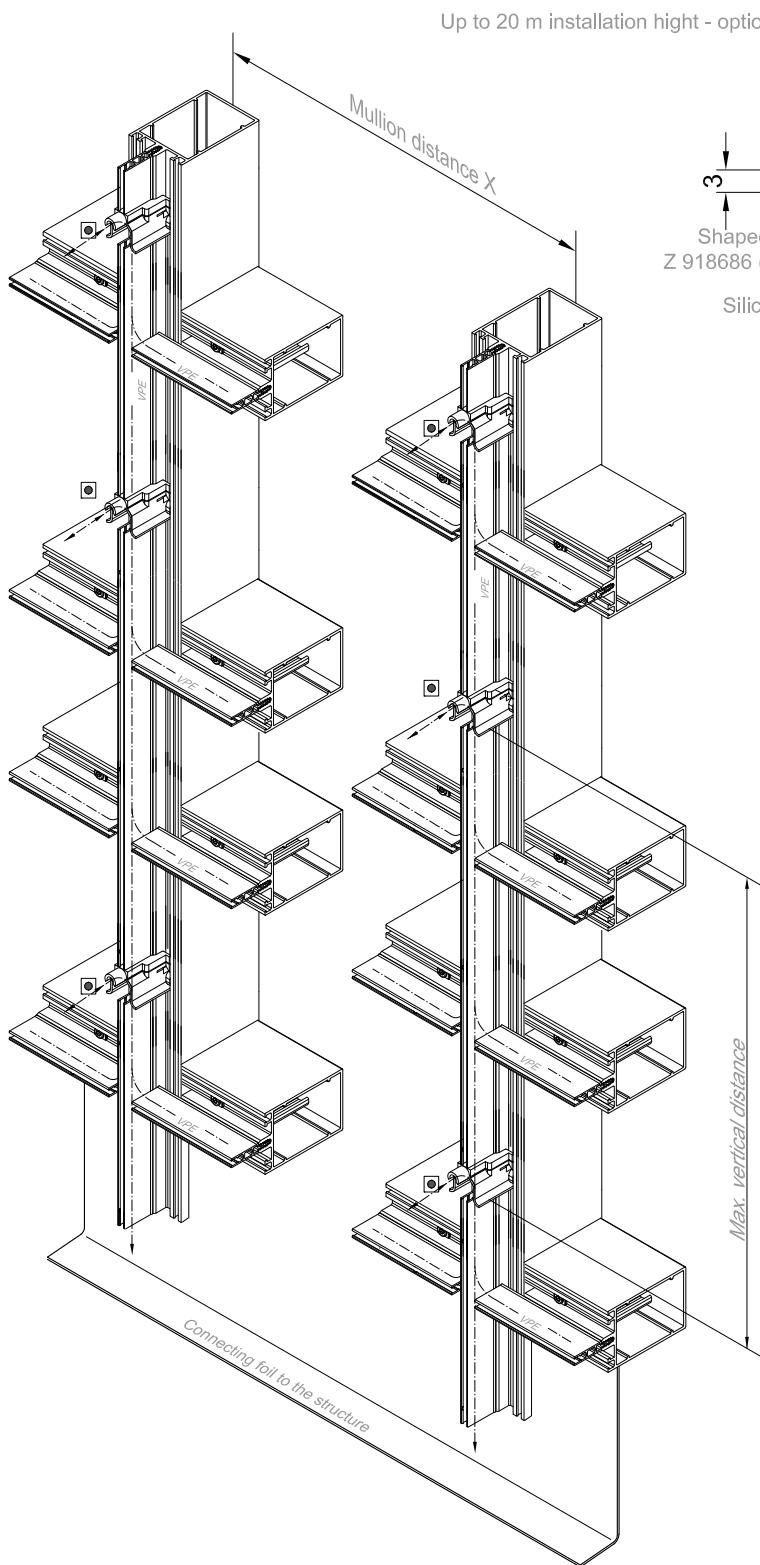

Vertical distance between zone ventilation blocks:
 c / c mullion $X < 1250 \text{ mm} = Y < 6000 \text{ mm}$
 c / c mullion $X > 1250 \text{ mm} = Y < 3000 \text{ mm}$

See also processing Trigon 50 / 60

173002300

● Shaped ventilation piece

----- Pressure equalisation

15.2 Ventilated glazing rebate

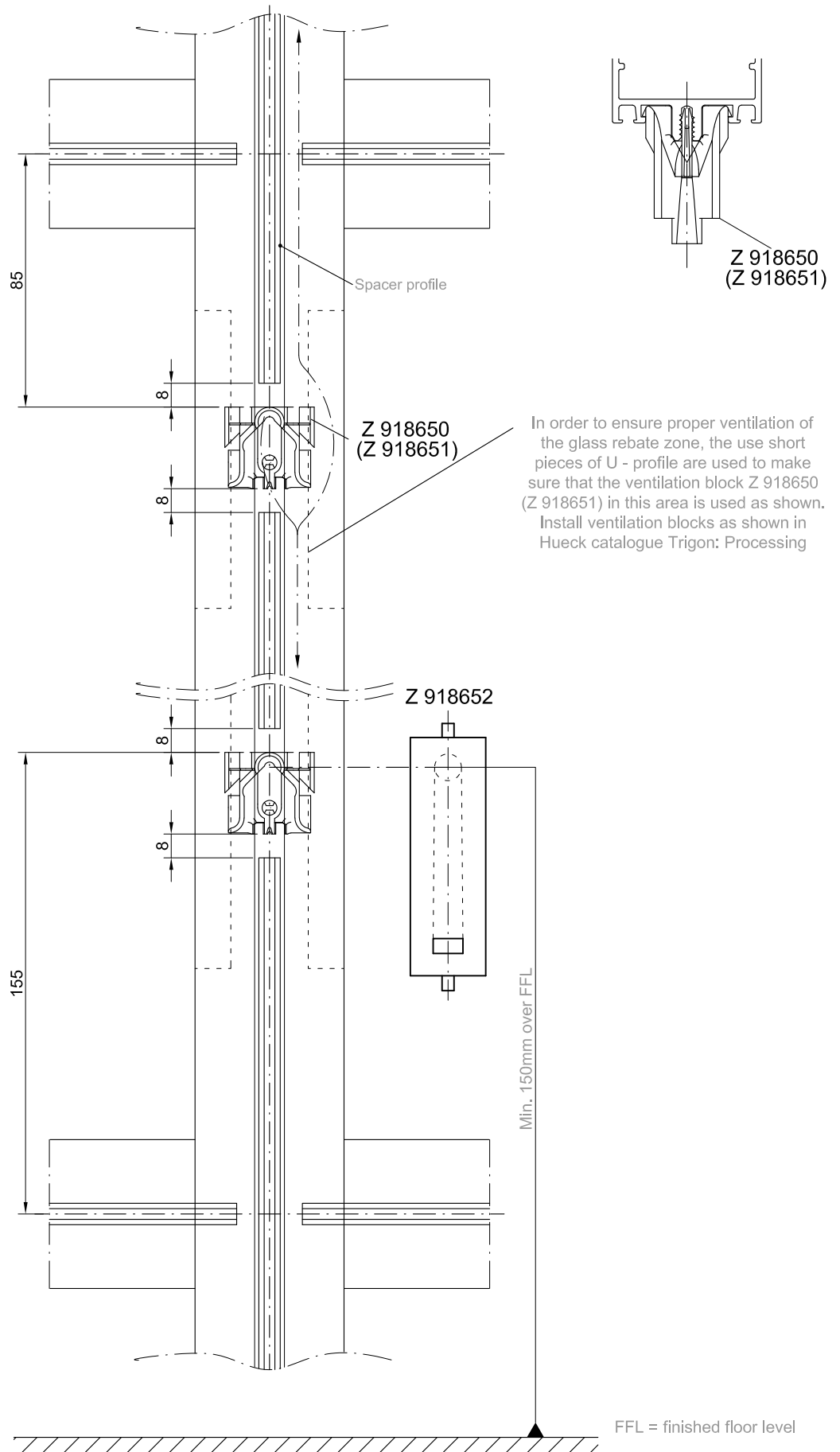

174002400

Transport and storage

Glass units may only be transported and stored in an upstanding position.

To avoid damages use distance pads of corc or of other materials which have to be placed between the glass units.

The glass units are not to be rested on corners or edges and must not be dragged or pushed over the floor. They always have to be placed on two wood- or plastic blocks. These blocks should never be in the area of the mechanical protection.

(See sketch below)

By using tension belts the glass edge has to be protected properly.

Glass units have to be stored in dry, good ventilated places or temporarily on site with coverage against UV radiation.

The bottom edge has to be protected from splash water and lasting moisture. Furthermore the surfaces have to be saved from alkaline substances as cement, lime etc.

Work like sandblasting, welding, grinding etc. may not be executed next to glass units without accurate protection of the glass.

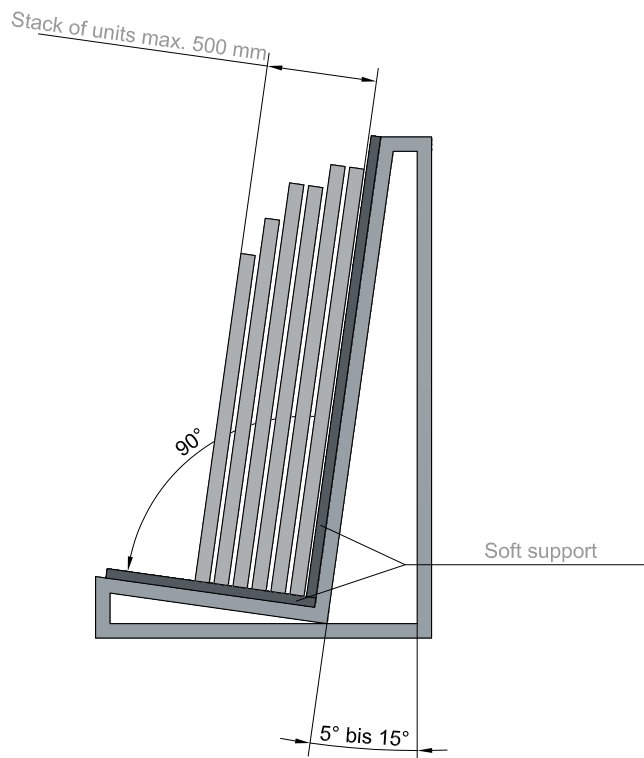

175002500

Glass packers

Packers and bridges have to be fixed permanently and secured against sliding or shifting.

See also DIN 18361 and EN 13022.

The bottom settingblocks have to be perpendicular to the glass edge.

Wrong

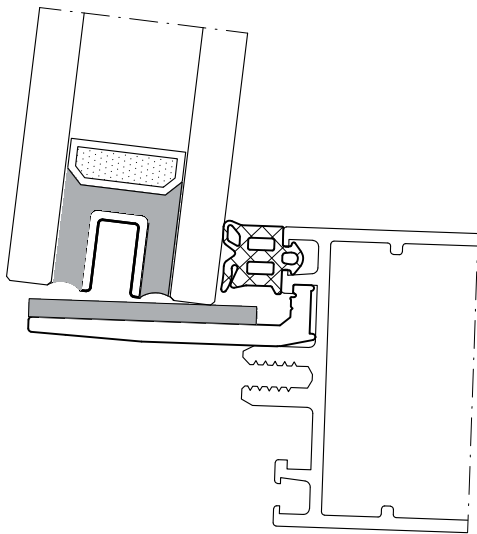

Correct

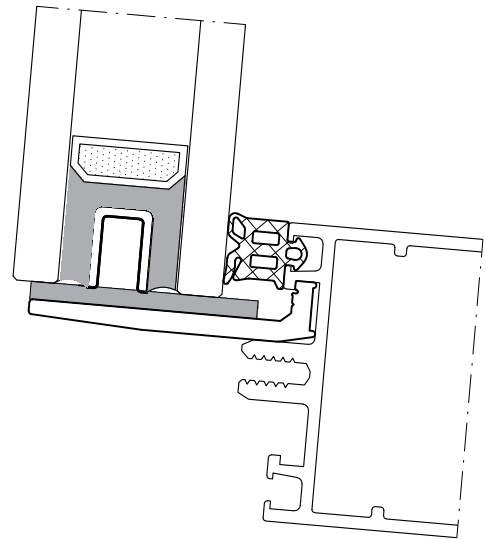

The surface treatment (Pos. 2+3) is to be in acc. with ETAG 002, and the bonding specifications of the bonding system supplier.

Please see also, the General References of our Catalogue Trigon 50 / 60-SG.

Glass assembly (toughened safety glass, laminated glass or float glass) must be coordinated before production with the regional requirements

Length of U-channel profile P 499760

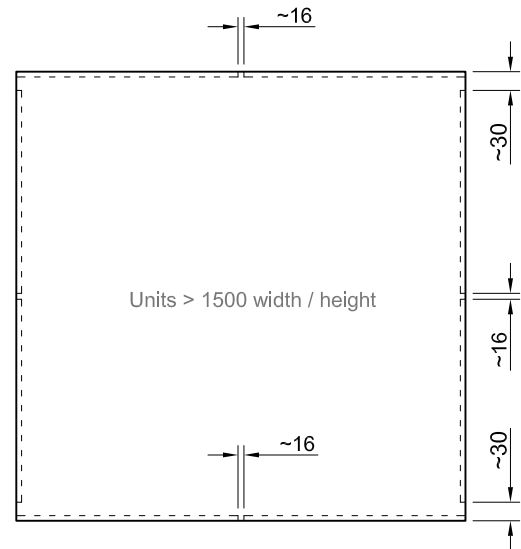
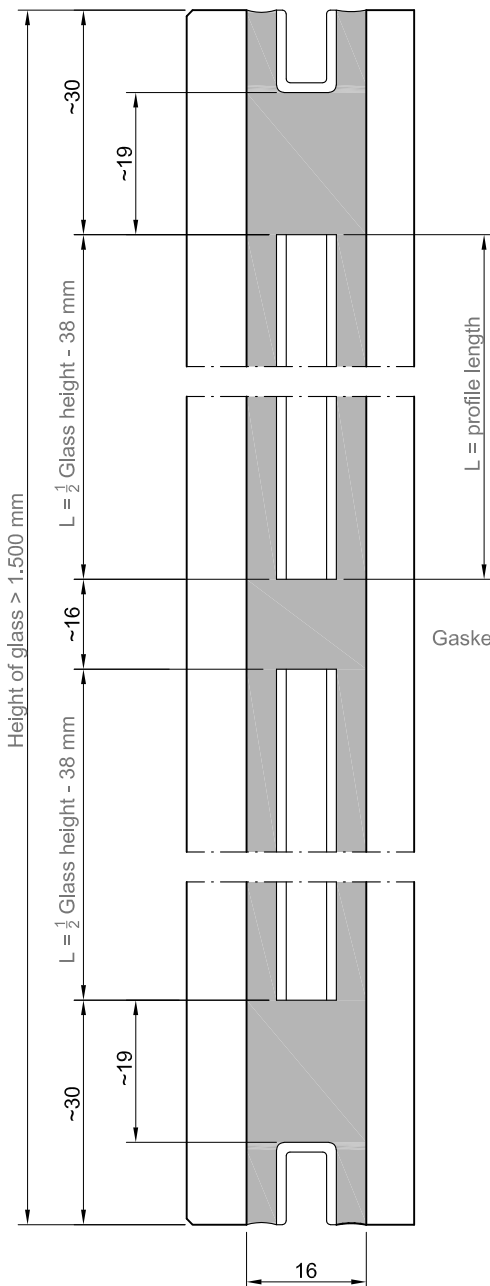
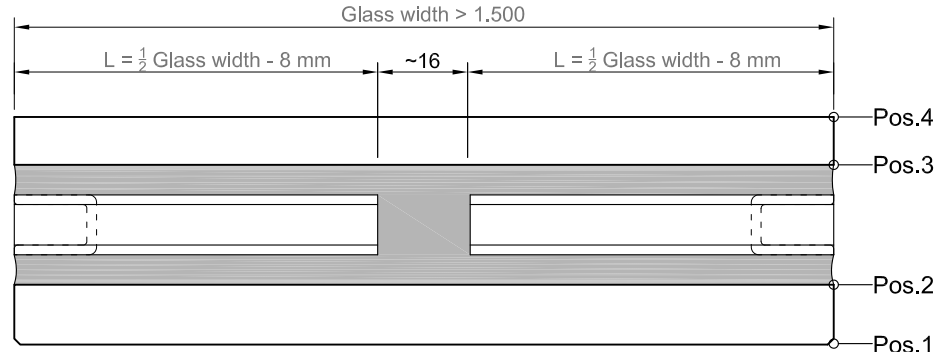

Gasket in according with glazing table

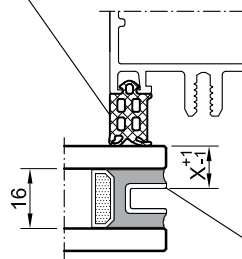

	Inner glass thickness	Measure (x)
Single glass	6	11.3
	8	13.3
	10	15.3
	12	17.3

P 499760
Surface treatment to be E6 / C0 in accordance with ETAG 002, resp. INOX in 2B.

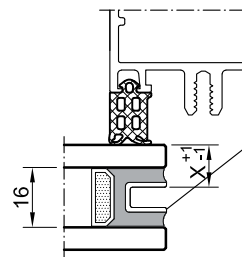

Bevelled external edge

	Inner glass thickness	Measure (x)
Laminated glass	6.8	12.1
	8.8	14.1
	10.8	16.1
	12.8	18.1

201000100

The surface treatment (Pos. 2+3) is to be in acc. with ETAG 002, and the bonding specifications of the bonding system supplier. Please see also, the General References of our Catalogue Trigon 50 / 60-SG. Glass assembly (toughened safety glass, laminated glass or float glass) must be coordinated before production with the regional requirements

Length of U-channel profile P 499760

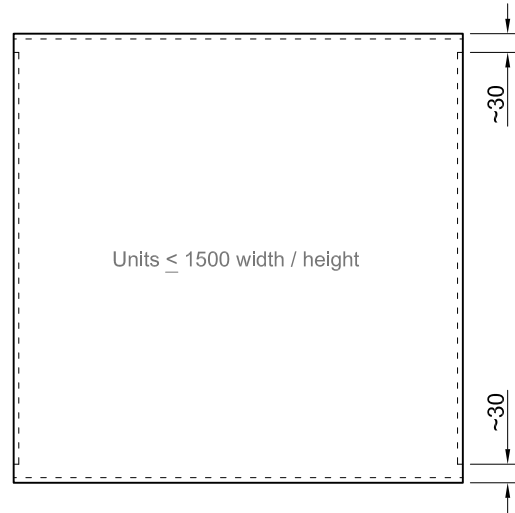
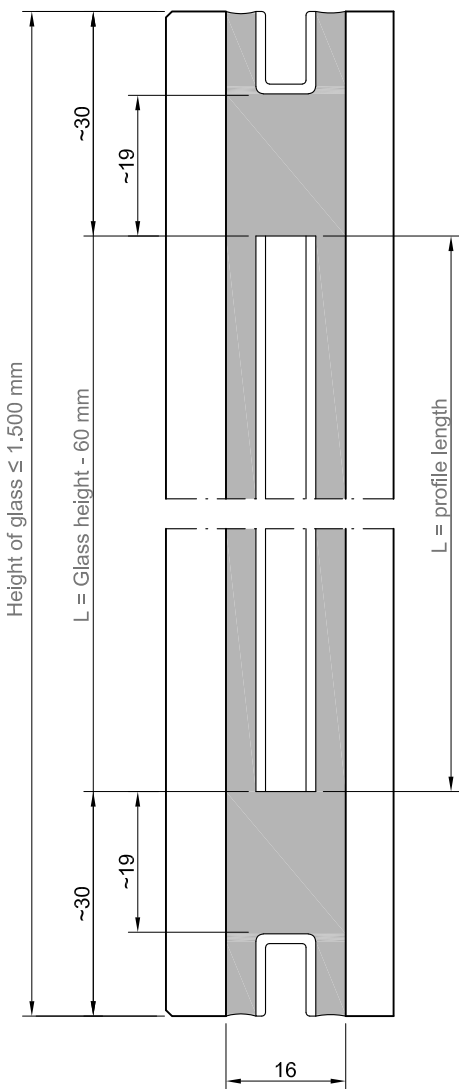
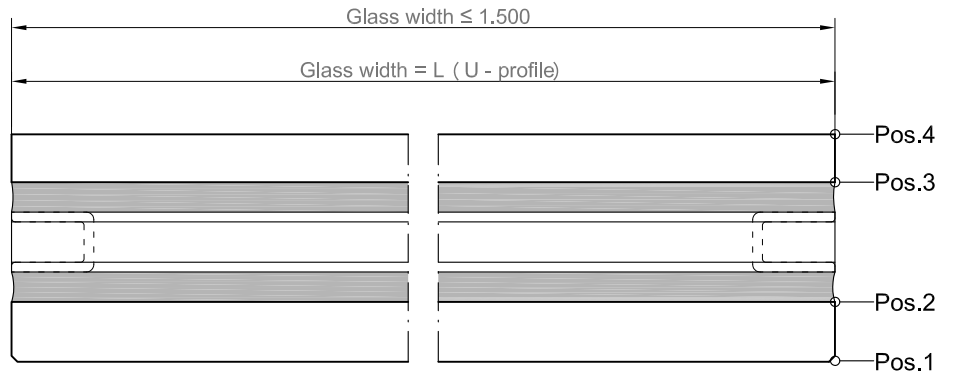

Gasket in accordance with glazing table

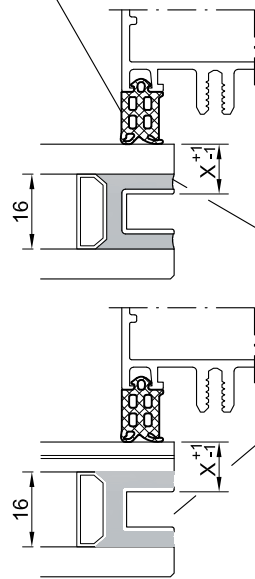

	Inner glass thickness	Measure (x)
Single glass	6	11.3
	8	13.3
	10	15.3
	12	17.3

P 499760
Surface treatment to be E6 / C0 in accordance with ETAG 002, resp. INOX in 2B.

	Inner glass thickness	Measure (x)
Laminated glass	6.8	12.1
	8.8	14.1
	10.8	16.1
	12.8	18.1

Bevelled external edge

The surface treatment (Pos. 2+3) is to be in acc. with ETAG 002, and the bonding specifications of the bonding system supplier.
Please see also, the General References of our Catalogue Trigon 50 / 60-SG.
Glass assembly (toughened safety glass, laminated glass or float glass) must be coordinated before production with the regional requirements

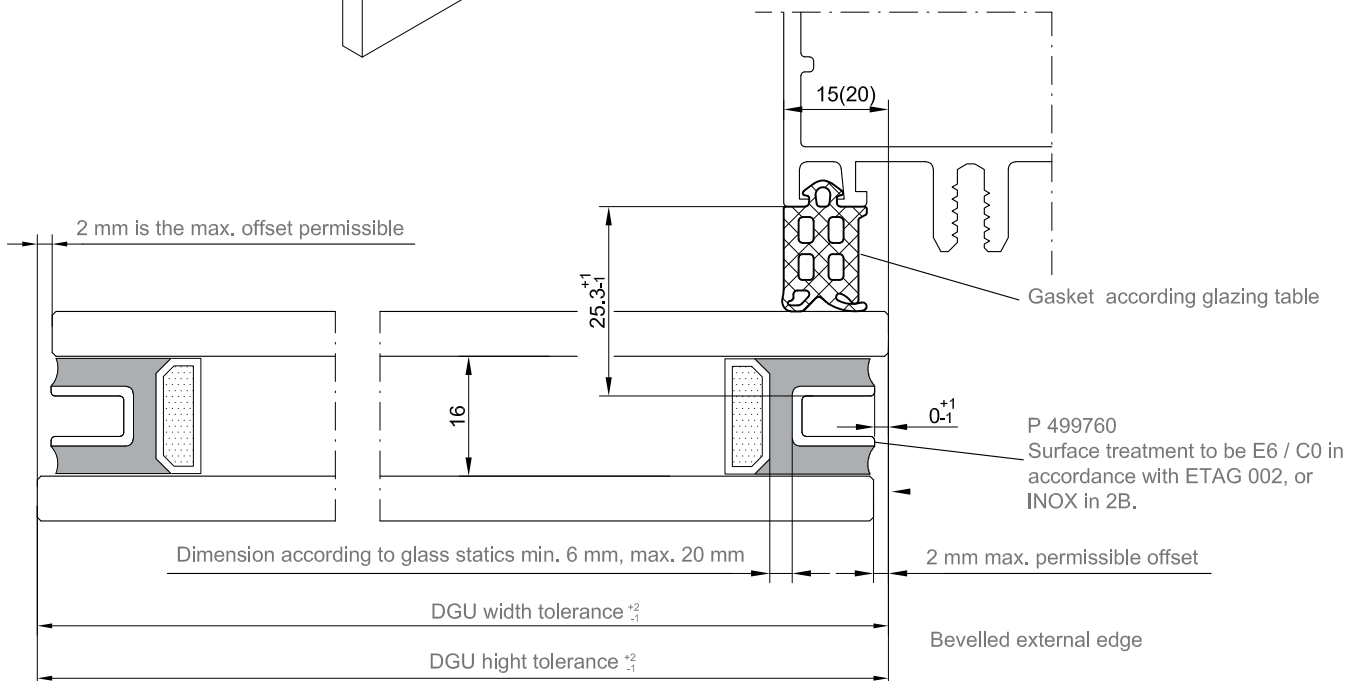
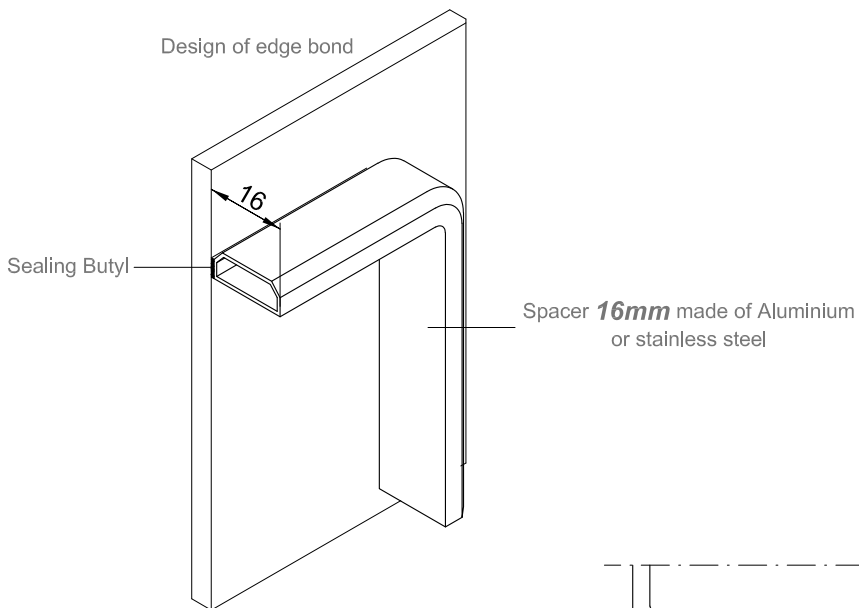
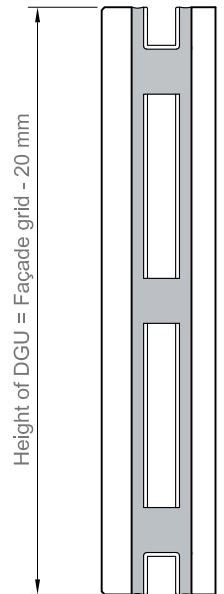
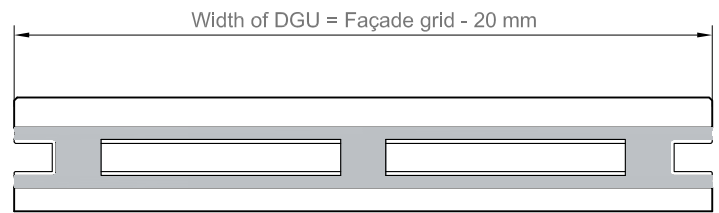

203000300

1 Tests regarding load-bearing bonding

Apart from testing the glue (a), adhesive tests of type A samples (b) and object-related tests of type B samples (c) are carried out. The substrate (glass pane and profile section) for the samples to be produced for points a, b and c below must be identical to the materials used in the producing system. The glass surface and the surface of the stainless steel profile are cleaned and pre-treated just like the glass panes and frame profile in current production, i.e. in line with the stipulations issued by the glue manufacturer.

(a) Glue tests carried out each working day

On production days, the following tests must be carried out three times a day in accordance with the stipulations issued by the glue manufacturer:

- homogeneity (no streaks)
- pot life
- Shore A hardness

(b) Adhesive tests carried out each working day, type A samples

On each production day, three samples on glass and three samples on stainless steel are produced, namely at the start of production, during production and at the end of production. Each of the samples is to be identified with date and time.

The following materials and tools are required for producing the samples:

The minimum size for mirror glass is approx. 35 mm x 250 mm, for coated toughened safety glass samples in the dimensions that can be produced are to be used. The profile sections must be from the same lot as the profiles for the respective object. The samples must be ordered from the metal worker with each delivery.

- Glue from continuous production
- Adhesive masking tape, approx. 25 mm wide
- Spatula with rectangular opening of 25 mm x 6 mm for creating a defined glue bead or flat spatulas and two spacers for confining the glue
- Sharp knife or one-sided razor blade.

Two short strips of masking tape are applied at a distance of approx. 200 mm, then an approx. 250 mm long glue bead with the dimension 25 mm x 6 mm is applied. This glue bead covers the first masking tape, is approx. 200 mm on the prepared substrate and covers another 25 mm of the second masking tape. Sample type A thus created is stored under the same surrounding conditions that exist during production of the elements that are used. After a curing time of at least 24 hours, the following test is carried out. One end of the glue bead is removed from the substrate, folded back and peeled off for one or two centimetres at an angle that is as flat as possible (see ill. 1). Then any part of the glue bead that might remain on the substrate is cut with the knife at the end of the tear-off joint up to the glue/substrate line and peeling off continues as described above. The process is finished only when the glue bead has been removed completely. Rupture must always occur within the glue (cohesion fracture). If the glue bead is torn off completely, the test may be continued at the other end of the bead. Assessment is based on the fracture pattern, with differentiation between adhesive fracture (in the junction between glue and substrate) and cohesive fracture (in the glue volume, also see ill. 1). Only cohesive fractures in the glue are permitted. The results are entered in the in-house production control protocol. All test specimens produced for each working day are to be stored until the next external supervision.



Glass / Aluminium-Profil

Picture 1 Adhesion test on samples of type A
 (left side: example for cohesion fracture, positive assessment;
 right side: example for adhesion fracture, negative assessment)

By using only the U-profile P 499760, a separated length of a profile has to be ordered and taken from the same anodized batch for testing.

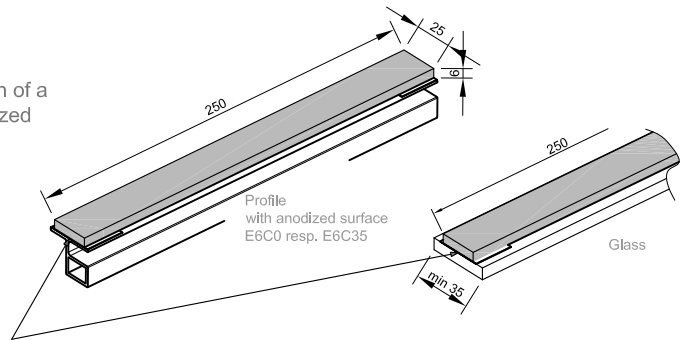

Spatula with a rectangular cutout 25 x 6 mm to produce a defined bead of adhesive and two masking tapes to limiting use of the adhesive.

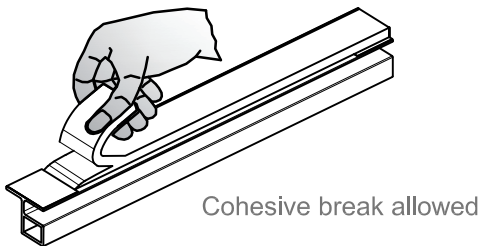

Three samples fixed on glass and three samples fixed on aluminium have to be produced before daily production starts, during, and end of production. The samples must be marked with date and time of production and must be archived.

Please also respect of section 8.3.2.5 from ETAG 002

205006500

Object-related tests of type B samples

The gluing body produces the respective number of type B samples with the defined glass and stainless steel surfaces (see III. 2).

The gluing body may carry out the tensile tests on samples B itself in the framework of its in-house production control.

Three samples each must be produced when a new glue container has been opened and at least twice a week. Type B samples are to be submitted to a tensile test at right angles to the glue joint. The smallest fracture stress value must be at least 0.8 N/mm². The share of the cohesive fracture must be at least 90% of the fracture surface.

III. 2 shows the type B test specimen.

Surface pre-treatment (detergent, primer) is in line with the specifications in the object-related notification by the glue manufacturer. When testing coated toughened safety glass, it is permitted to exceed the indicated sample size. The glue width for type B samples is 12 mm. The glue thickness for type B samples is 6 mm.

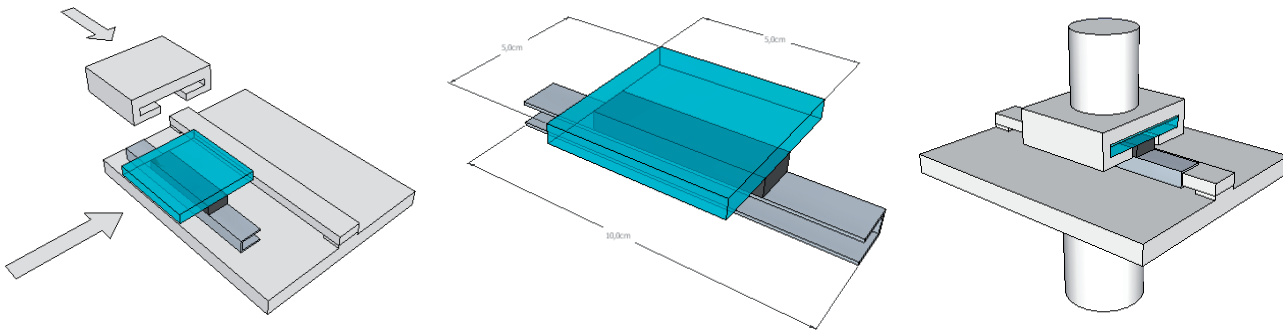

III. 2 Tensile test for type B samples

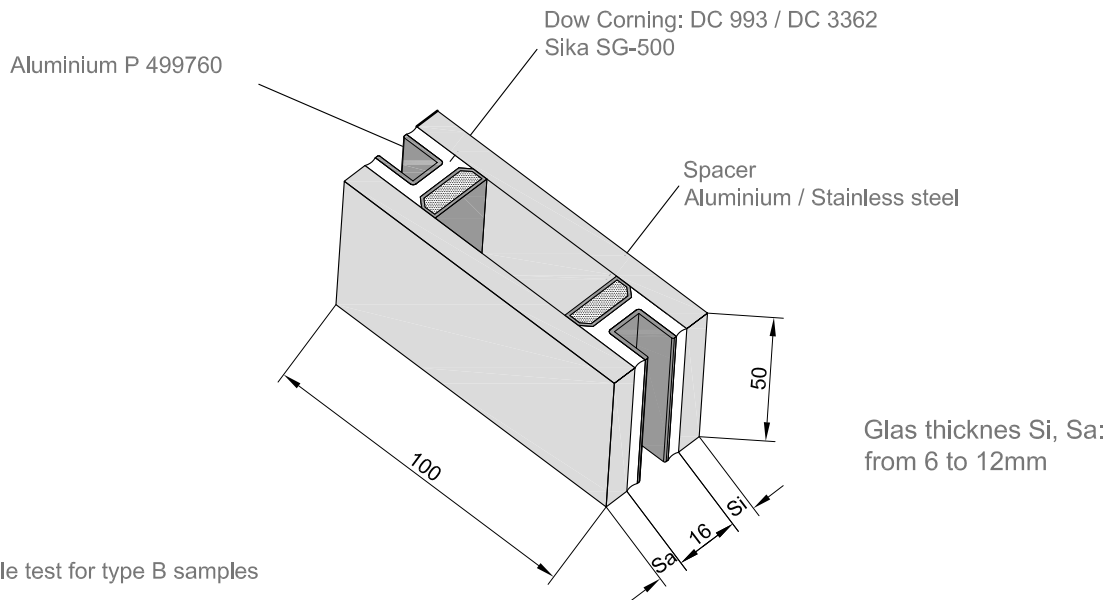

III. 3 Alternativ+e tensile test for type B samples

Notice:

The specimen have to be produced of the identical material (Glass, Aluminium or Stainless steel) as in the main production. All bonding surfaces have to be pre-treated as in the main production acc. to the specifications of the used bonding system.

206000600

1.2 Tests on finished insert elements

During the gluing process, all insert elements to be produced are to be submitted to a visual inspection to ensure that there are no cavities or blisters in the glued joint. The results of this visual inspection are to be documented.

