

**Lambda 110 NI**

**Top hung concealed window open out**

## Lambda - Top hung window

### Content - Lambda 110 NI

### Page

Content

2

Series Information

3 - 4

Profile overview | Static profile value

11

Profiles | Connections

12 - 16

Glazing

31 - 32

Sections / Details

41 - 48

System-dependent accessories

81 - 86

Fittings

101 - 104

Processing

151 - 168

Fitting Installation

201 - 204

002000200

## Modular system\*



<p><b>Modular system</b></p>	<ul style="list-style-type: none"> <li>• Intelligent modular system of different series for different requirements of functionality and aesthetics</li> <li>• Cost efficiencies on storage due to cross-serial use fittings, corner- and t-brackets, supplementary profiles and gaskets</li> <li>• Variety of design possibilities, narrow elevation widths, high-quality fitting and accessory parts for projecting out</li> </ul>
<p><b>Surfaces</b></p>	<ul style="list-style-type: none"> <li>• Anodisation in accordance with DIN 17611</li> <li>• Plastic coating (wet paint, powder coating lacquer) in accordance with DIN 50939</li> <li>• Can be coated at a later time</li> </ul>
<p><b>Connecting technology</b></p>	<ul style="list-style-type: none"> <li>• Corner bracket: crimpable, retro gluing after assembly</li> </ul>
<p><b>Opening types</b></p>	<p style="text-align: right;">Opening out </p>

## Series information\*

<p><b>Design features</b></p>	<ul style="list-style-type: none"> <li>• Single -chamber profiles</li> <li>• Max. sash weight 165 kg</li> </ul>
<p><b>Elevation width</b></p>	<ul style="list-style-type: none"> <li>• 51 mm narrow elevation width of frame/sash combination</li> </ul>
<p><b>Profile depth</b></p>	<ul style="list-style-type: none"> <li>• SG version: 90.5 mm **</li> </ul>
<p><b>Glazing</b></p>	<ul style="list-style-type: none"> <li>• Glass thickness between 24 mm and 36 mm</li> <li>• Stepped DGU, as SG sash</li> </ul>
<p><b>Gaskets</b></p>	<ul style="list-style-type: none"> <li>• 3 gasket system</li> <li>• continuously drawn in inner and outer rebate gasket for easy assembly and optimised tightness</li> </ul>

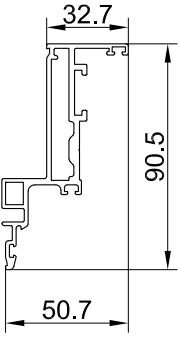
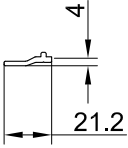
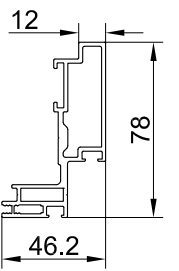
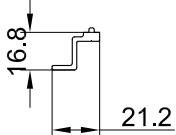
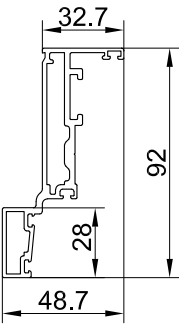
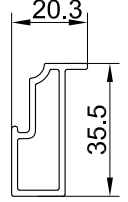
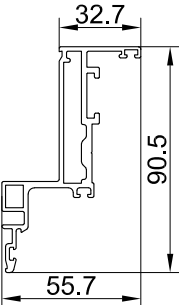
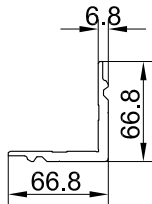
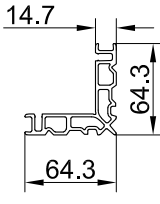
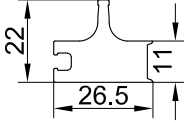

## Profile overview and static profile values for Series Lambda 110 NI

	Profile number	Horizontal axis		Vertical axis		External perimeter complete	Page		Profile number	Horizontal axis		Vertical axis		External perimeter complete	Page
		$J_x$ (cm <sup>4</sup> )	$W_x$ (cm <sup>3</sup> )	$J_y$ (cm <sup>4</sup> )	$W_y$ (cm <sup>3</sup> )					$J_x$ (cm <sup>4</sup> )	$W_x$ (cm <sup>3</sup> )	$J_y$ (cm <sup>4</sup> )	$W_y$ (cm <sup>3</sup> )		
	P 520240	34	7	7	2	374	13		P 420246	-	-	-	-	51	12
	P 520241	30	7	7	3	313	12		P 420247	-	-	-	-	77	12
	P 520244	43	8	6	2	349	14		P 520268	-	-	-	-	429	14
	P 520245	34	7	9	3	384	13		P 499605	-	-	-	-	271	15
011000100									P 599343	-	-	-	-	350	15
									P 499759	-	-	-	-	105	16



## P 520241

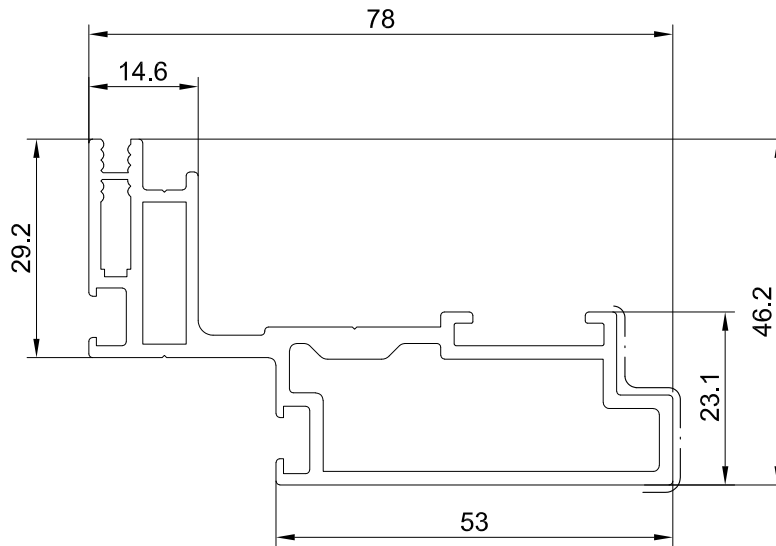

## P 420246

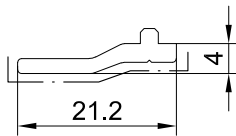



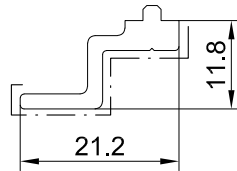



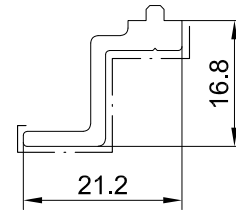

## P 420260



## P 420247



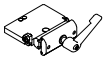



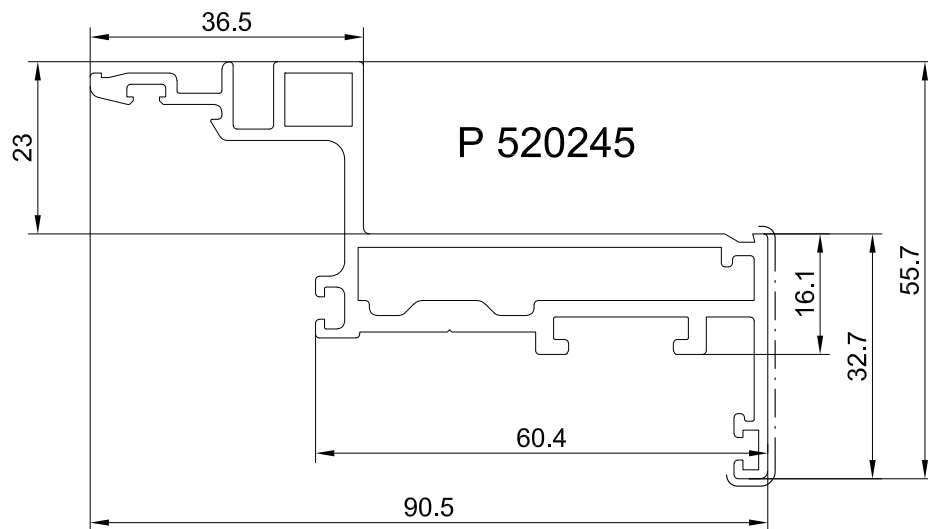
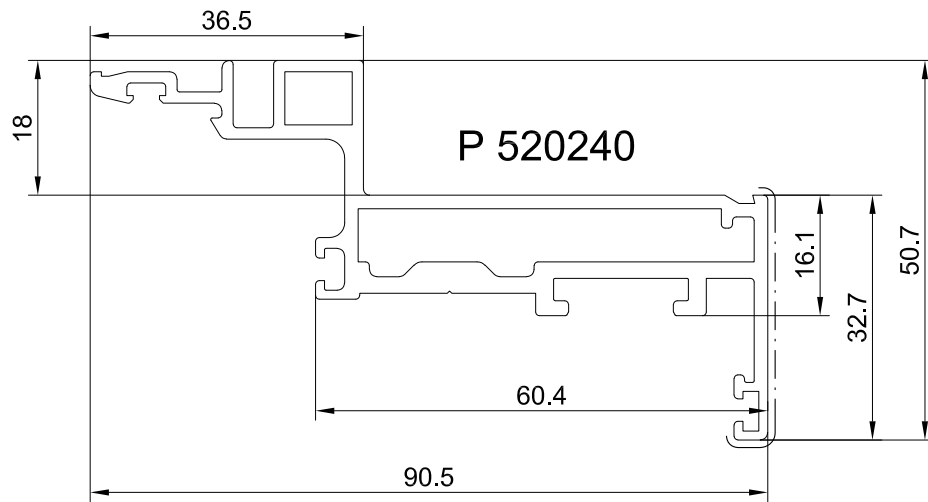



Scale 1:1

<ul style="list-style-type: none"> <li> crimpable</li> <li> nailable</li> <li> retro gluing after assembly</li> </ul>	chamber				
					
<b>P 520241</b>	-	Z 917986 / Z 923007	-	-	-
					
<b>P 420246</b>	Z 917187	-	-	-	-
<b>P 420260</b>	Z 917187	-	-	-	-
<b>P 420247</b>	Z 917187	-	-	-	-

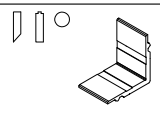

Scale 1:1

013000300



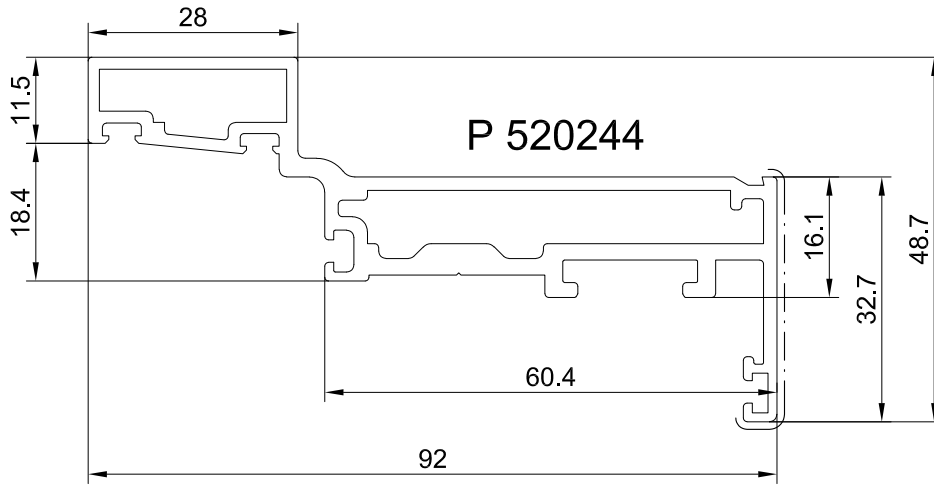
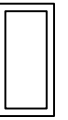



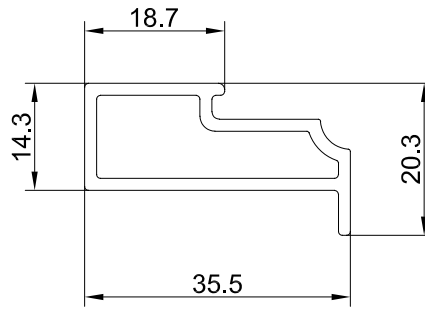

<ul style="list-style-type: none"> <li> crimpable</li> <li> nailable</li> <li> retro gluing after assembly</li> </ul>	chamber					
						
<b>P 520240</b>	-	Z 918590 / Z 918677	-	-	-	-
<b>P 520245</b>	-	Z 918590 / Z 918677	-	-	-	-



**P 520268**



Scale 1:1

<ul style="list-style-type: none"> <li> crimpable</li> <li> nailable</li> <li> retro gluing after assembly</li> </ul>	chamber				
					
<b>P 520244</b>	-	Z 918590 / Z 918676	-	-	-
<b>P 520268</b>	-	-	-	-	-

014000400



## P 499605

article no.:	profile no.:	cutting
Z918677	P499605	8,6 mm
Z918676	P499605	17,4 mm
Z918590	P499605	48,0 mm

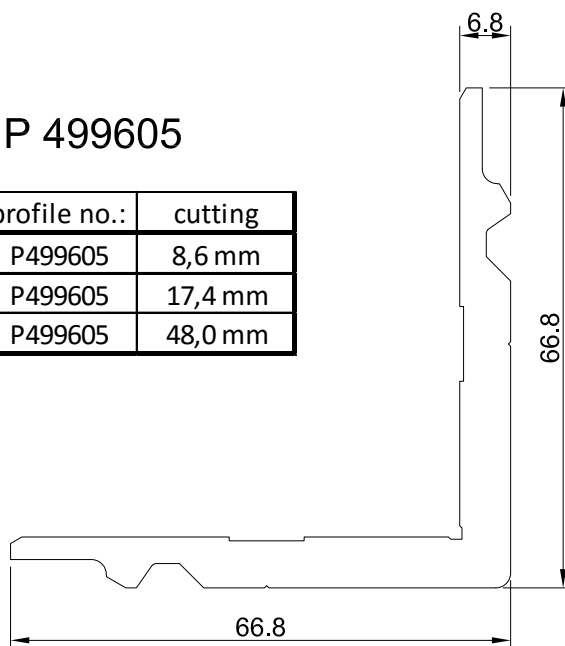

## P 599343

article no.:	profile no.:	cutting
Z923007	P599343	36,9 mm

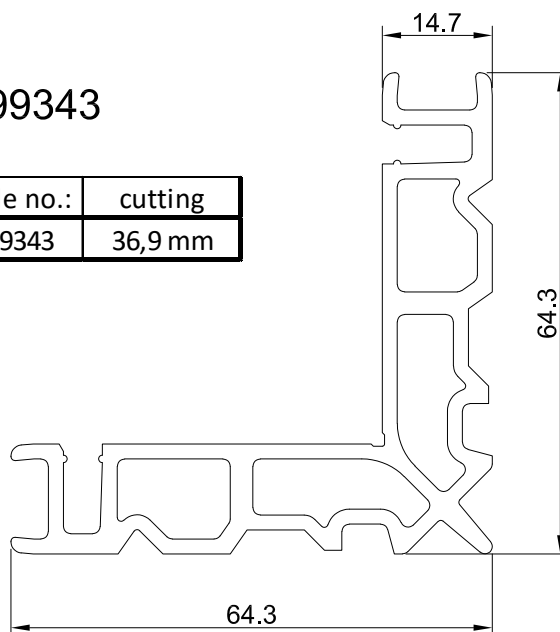

015006500

Scale 1:1

## P 499759

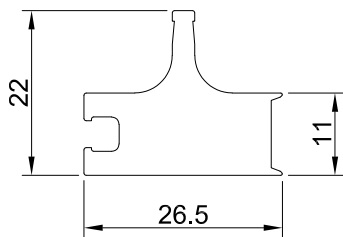

article no.:	profile no.:	cutting	gasket	screw
Z918576	P499759	35 mm	Z918588	2 x 911944

M = 2:1

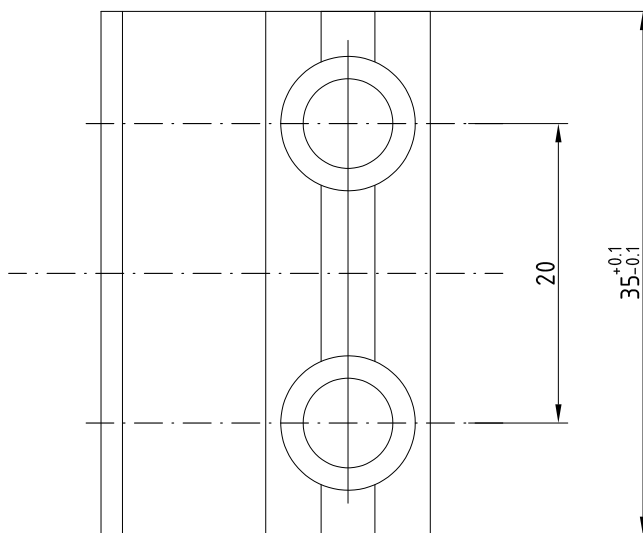
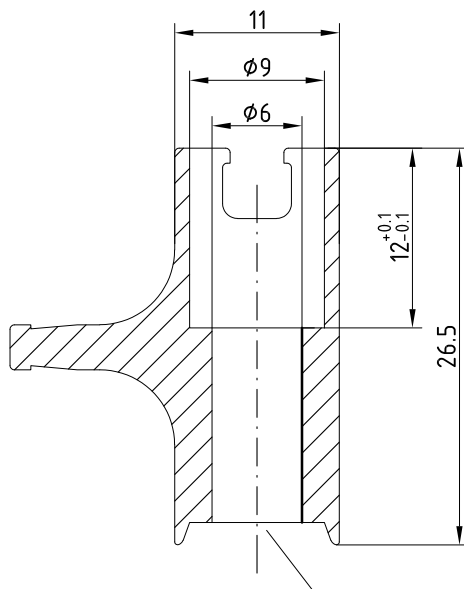

Scale 1:1

016000600

### Different thicknesses of outer and inner glass

outer glass

inner glass

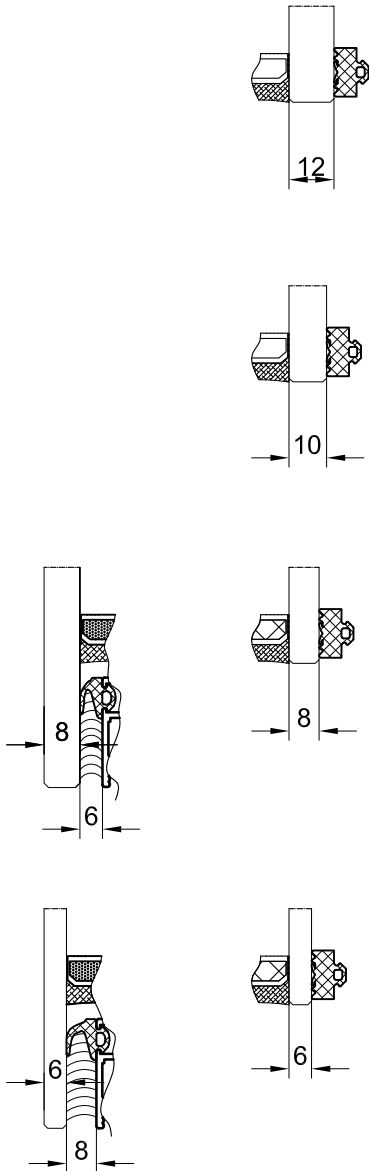

Thickness of outer pane

39		Glazing gasket
glass thickness		
24	15	Z 917722
25	14	Z 917721
26	13	Z 917720
27	12	Z 917719
28	11	Z 917718
29	10	Z 917717
30	9	Z 917716
31	8	Z 917715
32	7	Z 917714
33	6	Z 917713
34	5	Z 917712
35	4	Z 917711
36	3	Z 917710

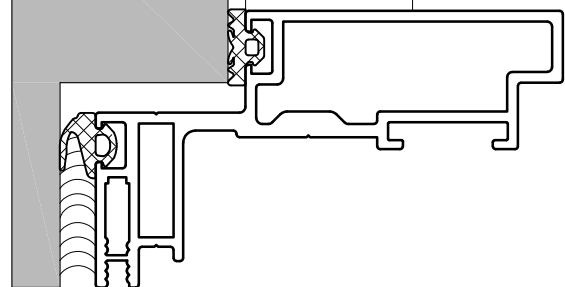

Internal glazing gasket							
Glass thickness internal pane	24 mm	25 mm	26 mm	27 mm	28 mm	29 mm	30 mm
Glazing gasket	15 mm Z 917722 25	14 mm Z 917721 25	13 mm Z 917720 25	12 mm Z 917719 25	11 mm Z 917718 25	10 mm Z 917717 25	9 mm Z 917716 25
Glass thickness internal pane	31 mm	32 mm	33 mm	34 mm	35 mm	36 mm	
Glazing gasket	8 mm Z 917715 25	7 mm Z 917714 25	6 mm Z 917713 25	5 mm Z 917712 25	4 mm Z 917711 25	3 mm Z 917710 25	

031000100

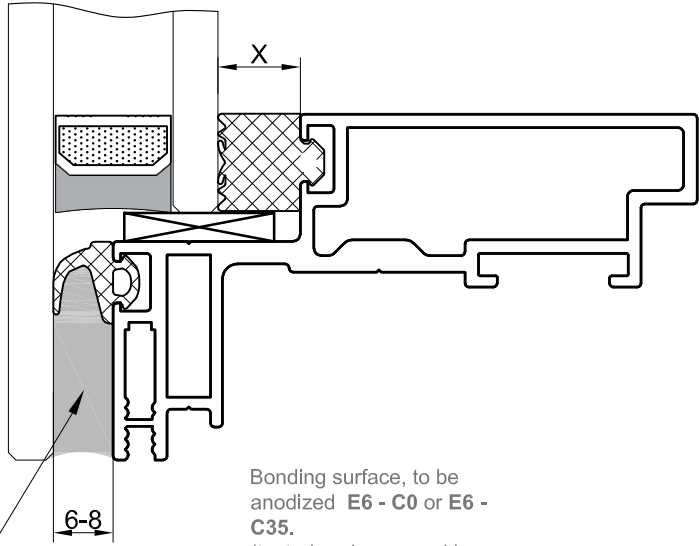

Dow Corning 993 /  
Sikasil SG 500  
by client

Bonding surface, to be  
anodized **E6 - C0** or **E6 -  
C35**.  
(tested and approved by  
bonding supplier)

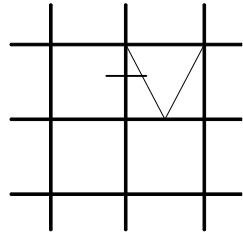

- |   |                |                   |
|---|----------------|-------------------|
| ① | Frame          | P 520244          |
| ② | Sash           | P 520241          |
| ③ | Rebate gasket  | Z 911025          |
| ④ | Glazing gasket | cf. glazing table |
| ⑤ | Screw          | Z 911893          |
| ⑥ | Backing gasket | Z 917611          |
| ⑦ | Cover gasket   | Z 918674          |

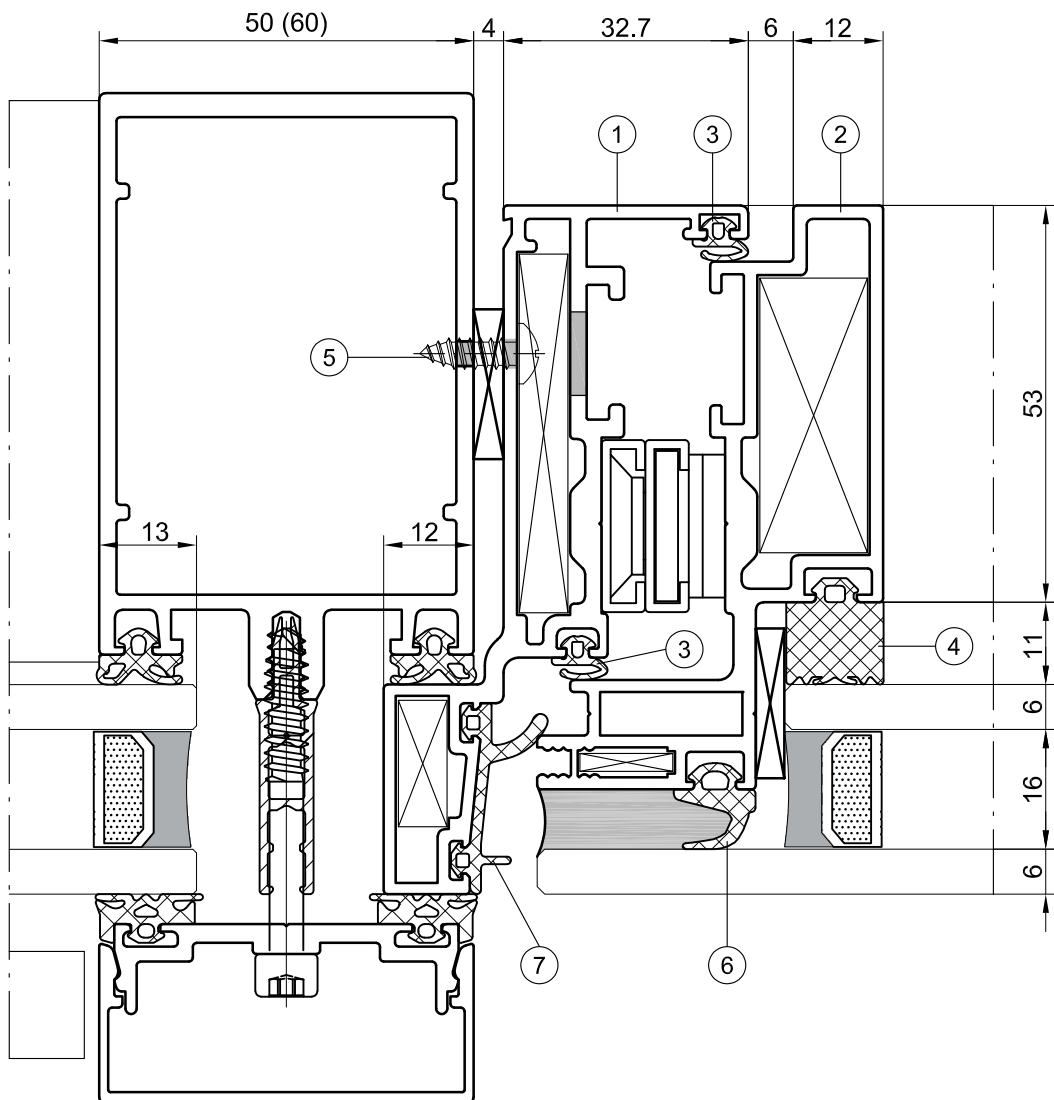

041000100

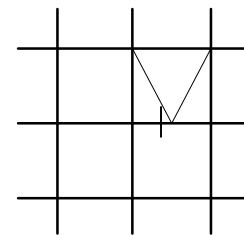

- |   |                |                   |
|---|----------------|-------------------|
| ① | Frame          | P 520244          |
| ② | Sash           | P 520241          |
| ③ | Rebate gasket  | Z 911025          |
| ④ | Glazing gasket | cf. glazing table |
| ⑤ | Screw          | Z 911893          |
| ⑥ | Backing gasket | Z 917611          |
| ⑦ | Cover gasket   | Z 918674          |
| ⑧ | Glazing beat   | P 420246          |
| ⑨ | Drilling screw | Z 917187          |

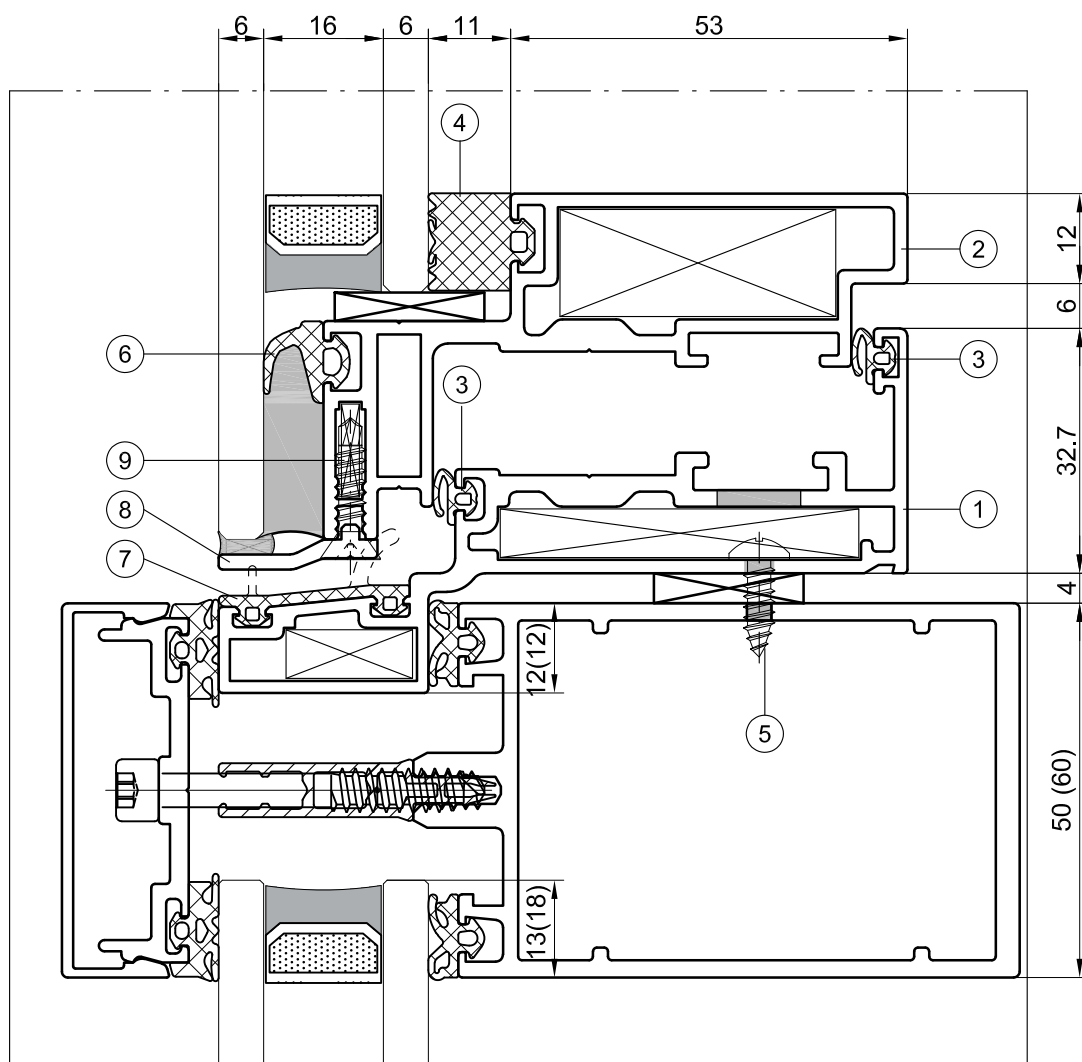

042000200

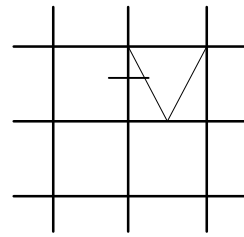

- |   |                   |                   |                         |
|---|-------------------|-------------------|-------------------------|
| ① | Frame             | P 520240          | (only for Trigon 50 NI) |
| ② | Sash              | P 520241          |                         |
| ③ | Rebate gasket     | Z 911025          |                         |
| ④ | Glazing gasket    | cf. glazing table |                         |
| ⑤ | Screw             | Z 911893          |                         |
| ⑥ | Backing gasket    | Z 917611          |                         |
| ⑦ | Connecting gasket | Z 918675          |                         |
| ⑧ | Single toggle     | Z 918576          |                         |
| ⑨ | Toggle gasket     | Z 918588          |                         |

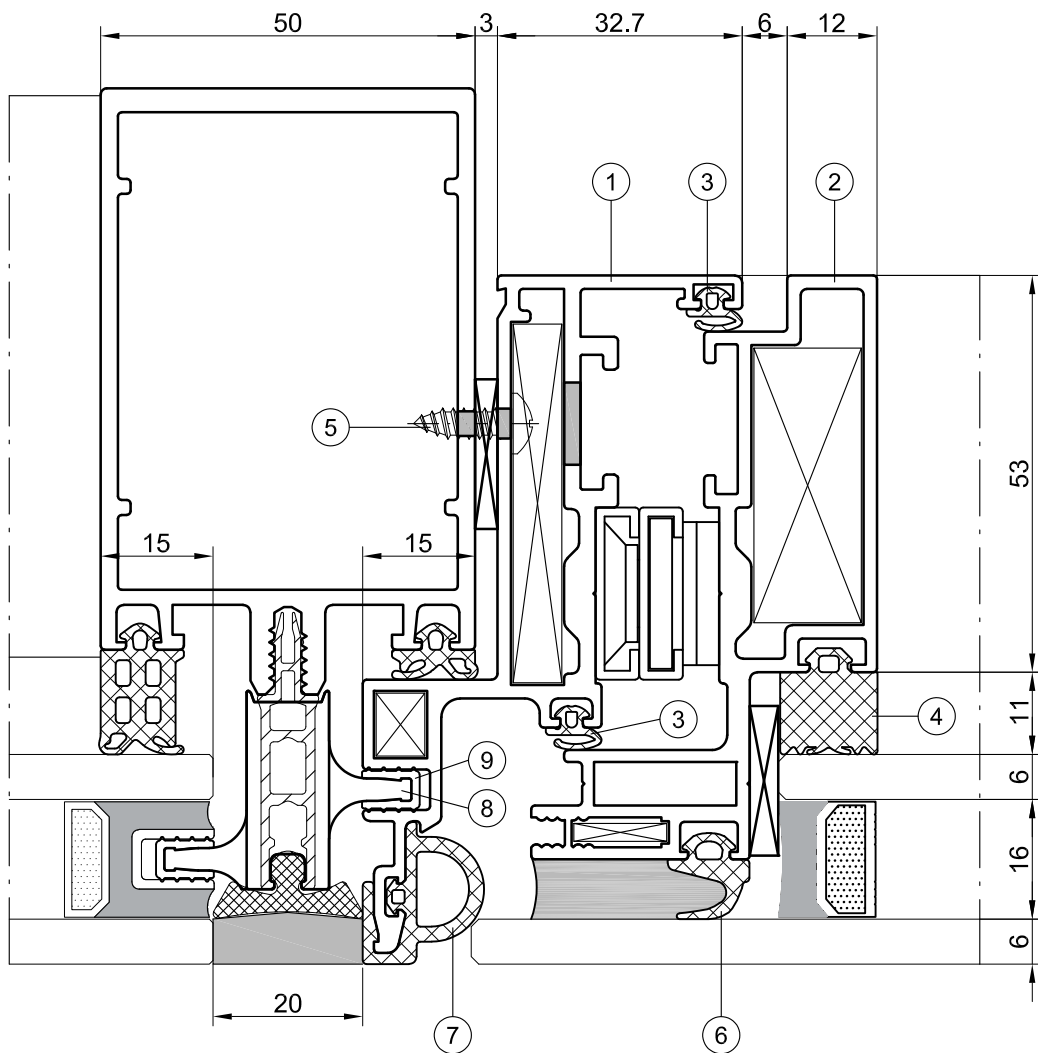

043000300

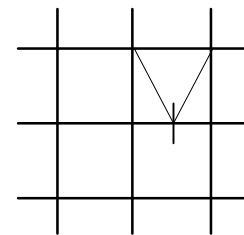

- |   |                   |                   |                         |
|---|-------------------|-------------------|-------------------------|
| ① | Frame             | P 520240          | (only for Trigon 50 NI) |
| ② | Sash              | P 520241          |                         |
| ③ | Rebate gasket     | Z 911025          |                         |
| ④ | Glazing gasket    | cf. glazing table |                         |
| ⑤ | Screw             | Z 911893          |                         |
| ⑥ | Backing gasket    | Z 917611          |                         |
| ⑦ | Connecting gasket | Z 918675          |                         |
| ⑧ | Glazing beat      | P 420260          |                         |
| ⑨ | Drilling screw    | Z 917187          |                         |
| ⑩ | Single toggle     | Z 918576          |                         |
| ⑪ | Toggle gasket     | Z 918588          |                         |

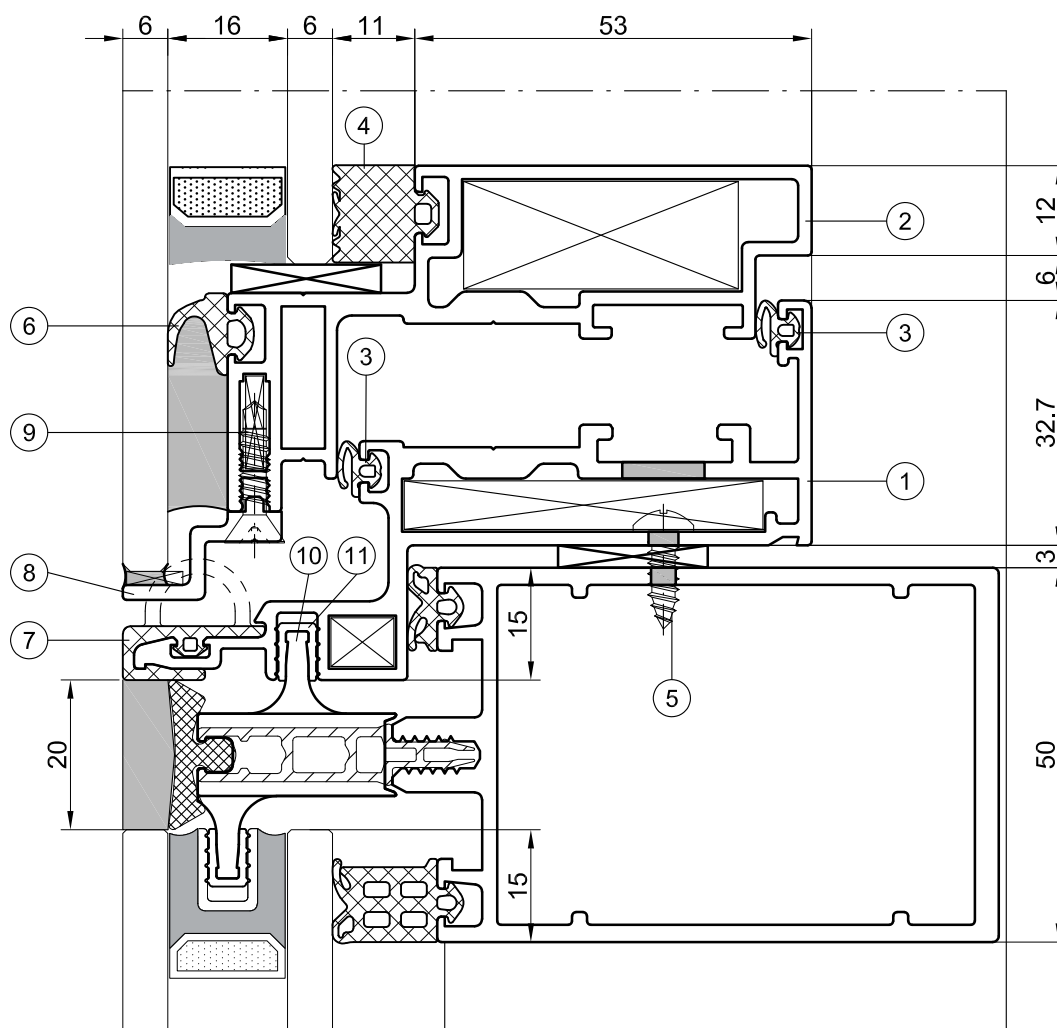

044000400



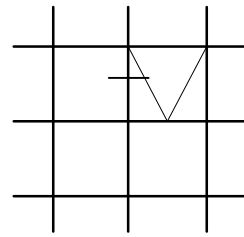

- |   |                   |                   |                         |
|---|-------------------|-------------------|-------------------------|
| ① | Frame             | P 520245          | (only for Trigon 60 NI) |
| ② | Sash              | P 520241          |                         |
| ③ | Rebate gasket     | Z 911025          |                         |
| ④ | Glazing gasket    | cf. glazing table |                         |
| ⑤ | Screw             | Z 911893          |                         |
| ⑥ | Backing gasket    | Z 917611          |                         |
| ⑦ | Connecting gasket | Z 918675          |                         |
| ⑧ | Single toggle     | Z 918576          |                         |
| ⑨ | Toggle gasket     | Z 918588          |                         |

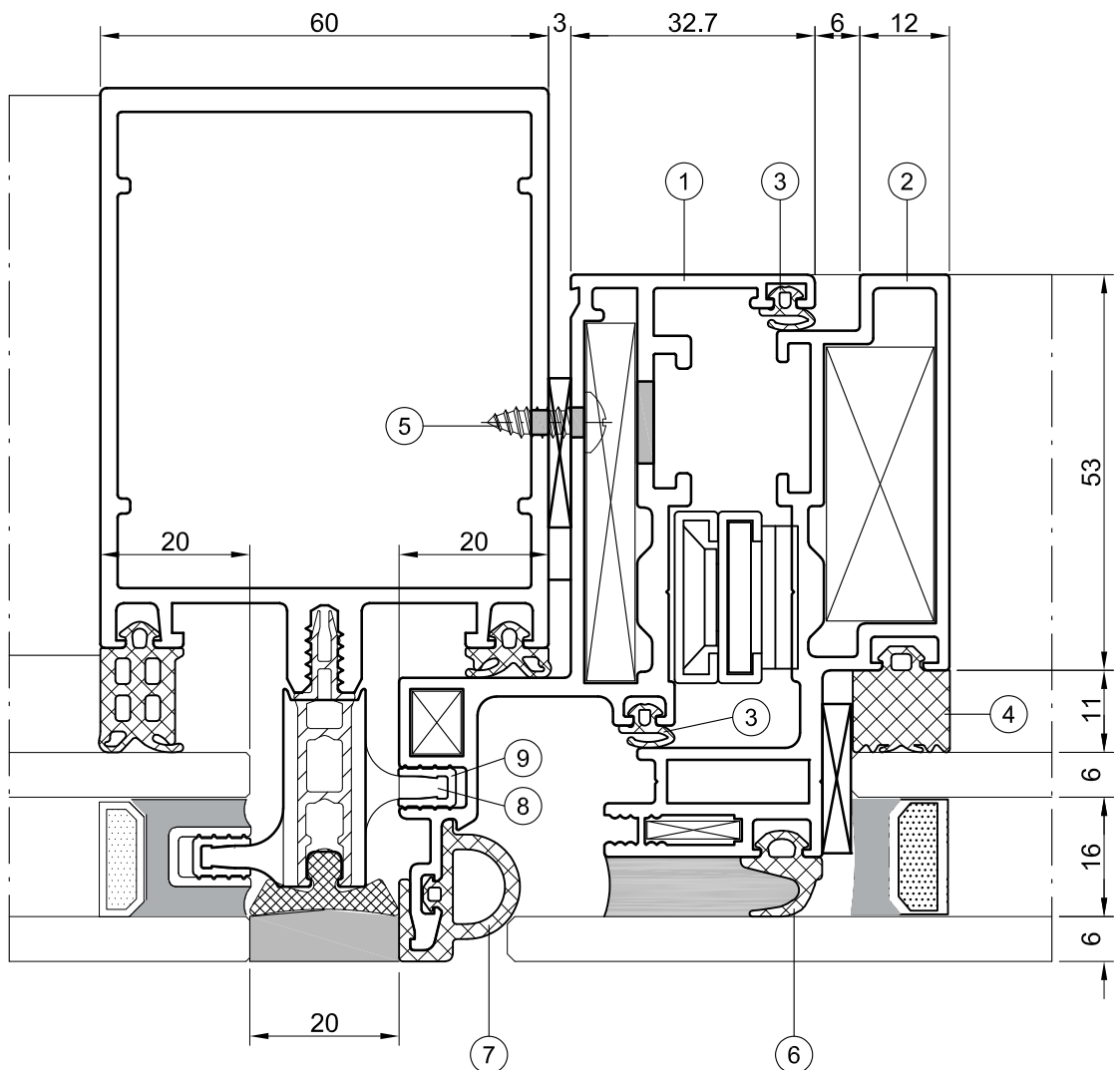

045006500

①	Frame	P 520245	(only for Trigon 60 NI)
②	Sash	P 520241	
③	Rebate gasket	Z 911025	
④	Glazing gasket	cf. glazing table	
⑤	Screw	Z 911893	
⑥	Backing gasket	Z 917611	
⑦	Connecting gasket	Z 918675	
⑧	Glazing beat	P 420247	
⑨	Drilling screw	Z 917187	
⑩	Single toggle	Z 918576	
⑪	Toggle gasket	Z 918588	
⑫	Setting block	Z 917957	

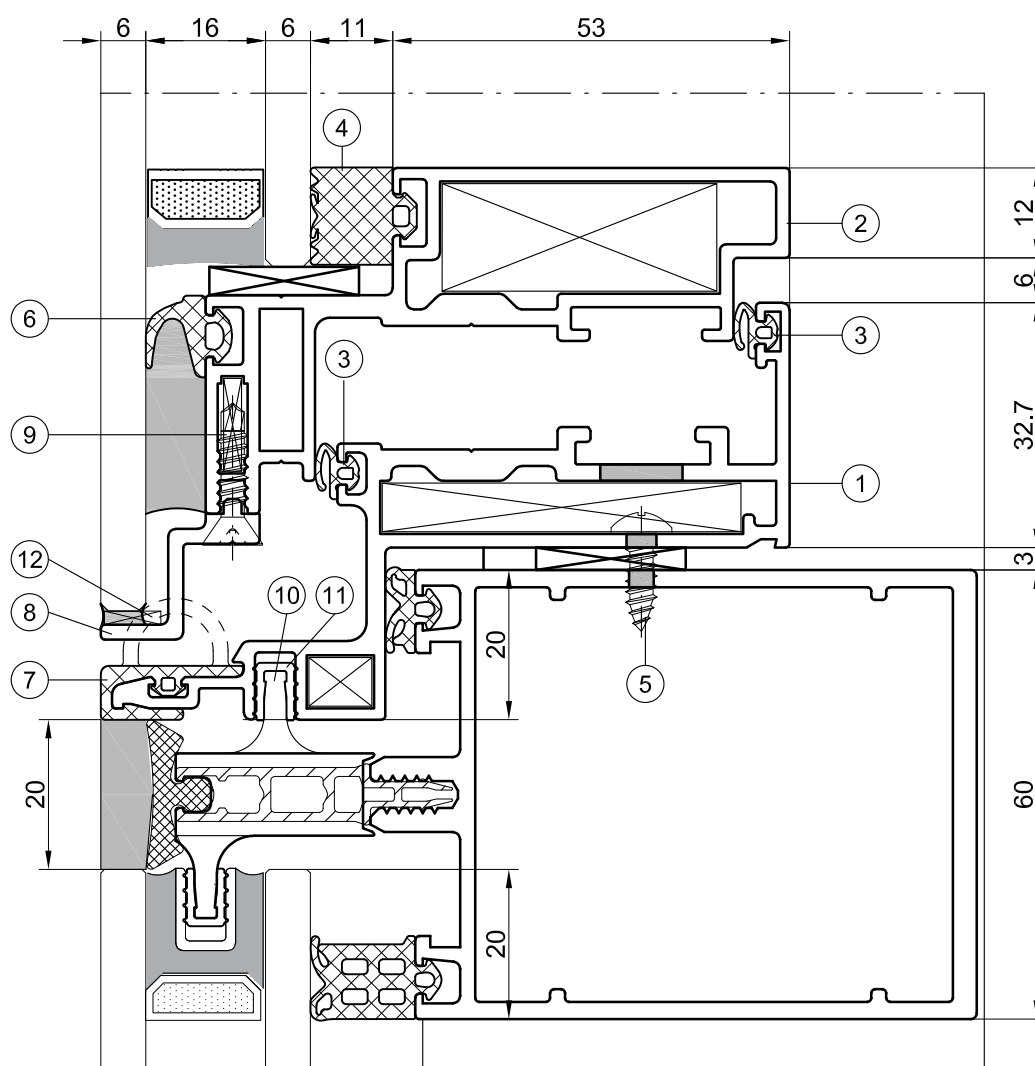
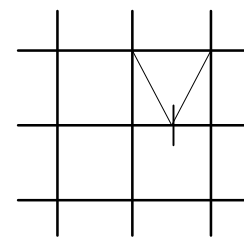

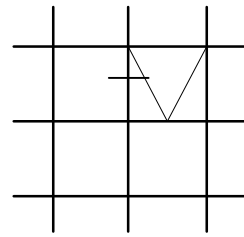

- |   |                |  |
|---|----------------|--|
| ① | Frame          | P 520245 (only for Trigon 60 NI and Trigon 60 SG NI) |
| ② | Sash           | P 520241   |
| ③ | Rebate gasket  | Z 911025   |
| ④ | Glazing gasket | cf. glazing table                                    |
| ⑤ | Screw          | Z 911893   |
| ⑥ | Backing gasket | Z 917611   |
| ⑦ | Adapter SSG    | P 520268   |
| ⑧ | Single toggle  | Z 918576   |
| ⑨ | Toggle gasket  | Z 918588   |

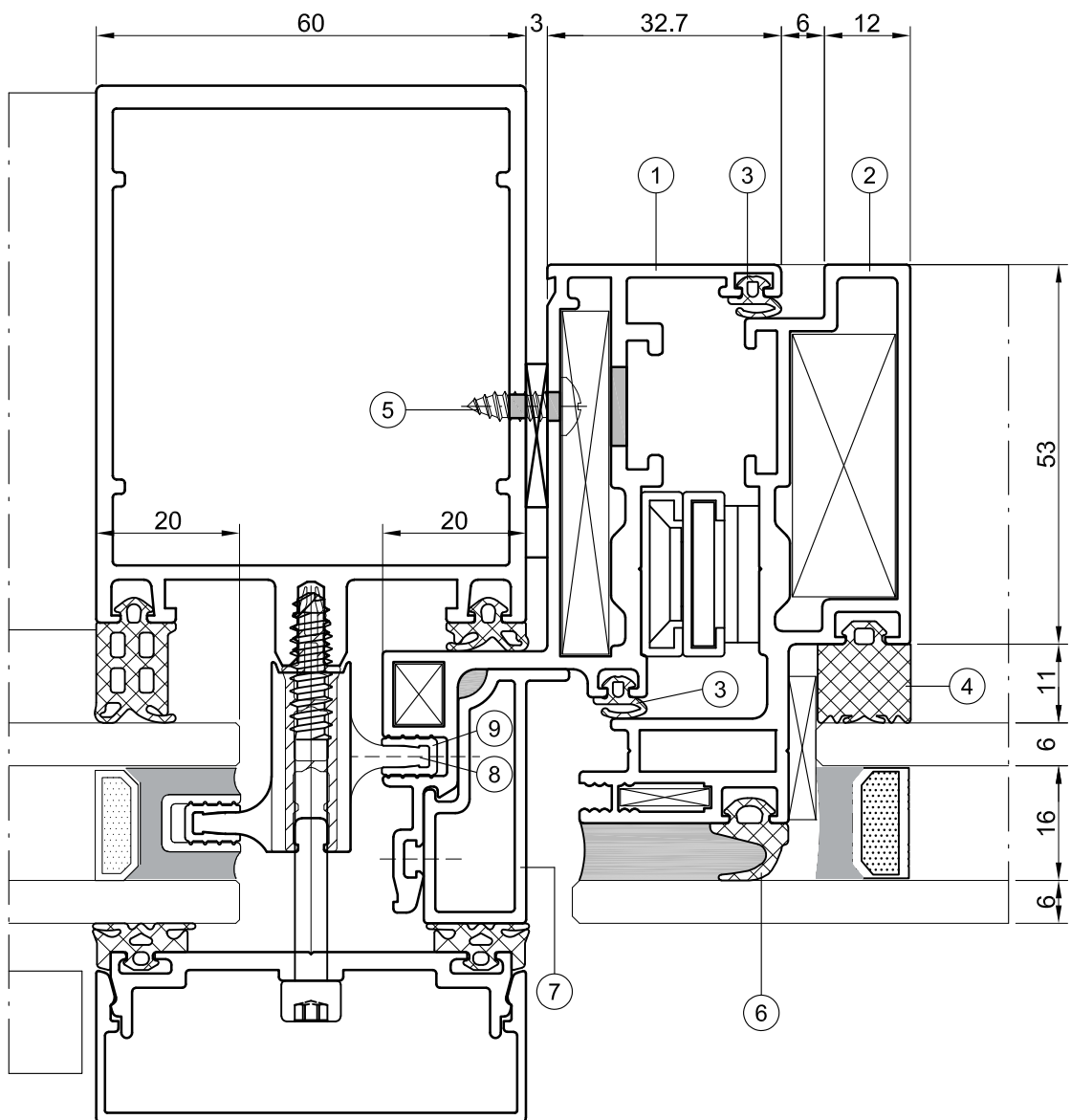

047000700



### Glazing gaskets - internal -

opening type



#### Z 917710 25

Glazing gasket  
made of EPDM, black,  
Surface: gliding polymer  
for 3 mm gap



#### Z 917711 25

Glazing gasket  
made of EPDM, black,  
Surface: gliding polymer  
for 4 mm gap



#### Z 917712 25

Glazing gasket  
made of EPDM, black,  
Surface: gliding polymer  
for 5 mm gap



#### Z 917713 25

Glazing gasket  
made of EPDM, black,  
Surface: gliding polymer  
for 6 mm gap



#### Z 917714 25

Glazing gasket  
made of EPDM, black,  
Surface: gliding polymer  
for 7 mm gap



#### Z 917715 25

Glazing gasket  
made of EPDM, black,  
Surface: gliding polymer  
for 8 mm gap

081000200

### Glazing gaskets - internal -

opening type



#### Z 917716 25

Glazing gasket  
made of EPDM, black,  
Surface: gliding polymer  
for 9 mm gap



#### Z 917717 25

Glazing gasket  
made of EPDM, black,  
Surface: gliding polymer  
for 10 mm gap

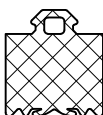

#### Z 917718 25

Glazing gasket  
made of EPDM, black,  
Surface: gliding polymer  
for 11 mm gap

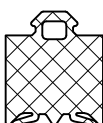

#### Z 917719 25

Glazing gasket  
made of EPDM, black,  
Surface: gliding polymer  
for 12 mm gap

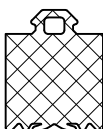

#### Z 917720 25

Glazing gasket  
made of EPDM, black,  
Surface: gliding polymer  
for 13 mm gap

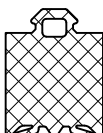

#### Z 917721 25

Glazing gasket  
made of EPDM, black,  
Surface: gliding polymer  
for 14 mm gap

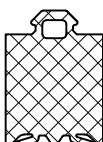

#### Z 917722 25

Glazing gasket  
made of EPDM, black,  
Surface: gliding polymer  
for 15 mm gap

082000200



### Z 911025 25

Rebate gasket  
made of EPDM, black,  
Surface: gliding polymer

opening type



### Z 918588 23

Toggle gasket  
made of silicone,



### Z 917611 23

Backing gasket  
made of silicone, black  
for glass bonding



### Z 901297 25

Joint gasket  
made of EPDM, black,  
Surface: gliding polymer  
for gap dimensions of 3.5 - 5 mm,

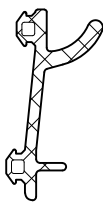

### Z 918674 22

Fusion gasket  
made of EPDM, black,  
Surface: siliconized

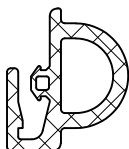

### Z 918675 23

Fusion gasket  
made of silicone, black,

0693000300

### Z 918590

Corner bracket 48 mm  
(from profil 499605)  
for crimping

### Z 918676

Corner bracket 17,4 mm  
(from profil 499605)  
for crimping

### Z 918677

Corner bracket 8,6 mm  
(from profil 499605)  
for crimping

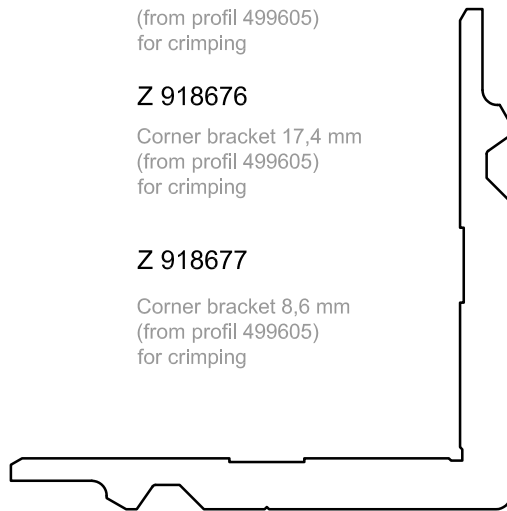

### Z 923007

Corner bracket 36,9mm  
(from profil 599343)

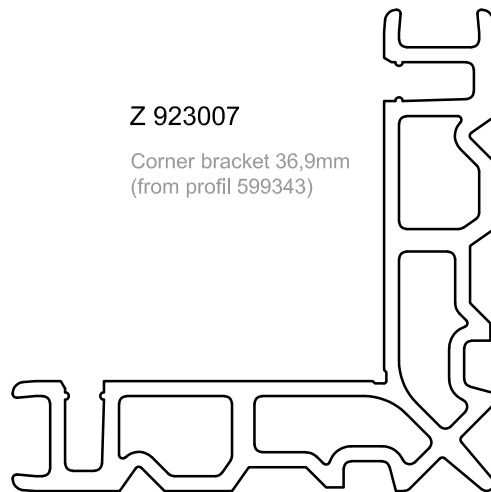

### Z 917986

Corner bracket  
made of Aluminium,  
for B 519201, for crimping

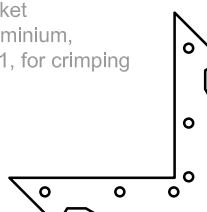

084000400



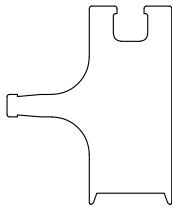

### Z 918576

Single toggle,  
made of aluminium,  
Length: 35 mm

opening type

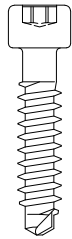

### Z 911944

Torx screw, T25, VF 50 / VF 60,  
dimension ST 5,9 x 25

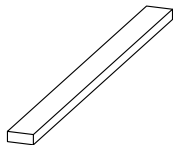

### Z 917957

Setting block  
made of silicon,black,  
3 x 7 mm

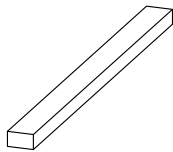

### Z 917958

Setting block  
made of silicon,black,  
4 x 7 mm

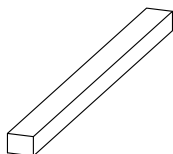

### Z 917959

Setting block  
made of silicon,black,  
5 x 7 mm

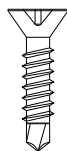

### Z 917187

Self drilling screw,  
with Phillips head St 4,2 x 19 mm,  
DIN 7504

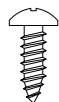

### Z 911893

Lens sheet - metal screw  
with Phillips head St 4,2 x 13 mm  
DIN 7981

0850006500

### Two-component glue



#### Z 911737

Two-component glue in dual cartridges, 620 ml PU = 6



#### Z 911738

Statik mixer, required for dual cartridges PU = 50



#### Z 912717

Sealing material, grey, EPDM suitable, processing temperature 5 - 40 ° Celsius PU = 310 ml in foil cartridge



#### Z 912718

Sealing material, black, EPDM suitable, processing temperature 5 - 40 ° Celsius PU = 310 ml in foil cartridge



#### Z 903941

EPDM - glue, black for sealing mitre joints on glazing gaskets processing temperature 12°-40°C, durability 6 months PU = 200 g tube

PU = packing unit

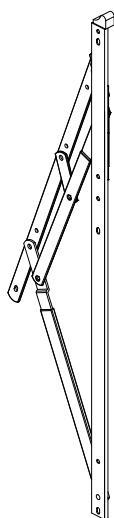

①

Art. no.	Size inch	Opening angle	Sash weight	Sash height min / max.
<b>Z 997435</b>	10	15° - 40°	55 kg - 35 kg	450 mm / 600 mm
<b>Z 997436</b>	12	10° - 40°	80 kg - 45 kg	600 mm / 800 mm
<b>Z 997437</b>	14	10° - 40°	95 kg - 50 kg	800 mm / 1000 mm
<b>Z 997438</b>	16	8° - 35°	115 kg - 65 kg	1000 mm / 1200 mm
<b>Z 997439</b>	18	7° - 35°	130 kg - 75 kg	1200 mm / 1400 mm
<b>Z 997440</b>	20	6° - 30°	140 kg - 100 kg	1400 mm / 1600 mm
<b>Z 997441</b>	22	5° - 30°	145 kg - 110 kg	1600 mm / 1800 mm
<b>Z 997442</b>	24	5° - 25°	150 kg - 120 kg	1600 mm / 1800 mm
<b>Z 997443</b>	28	3° - 20°	165 kg - 140 kg	1800 mm / 2000 mm

Stay hinge  
Packing unit left and right

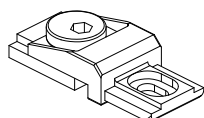

②

**Z 914455**

height adjustment  
Packing unit (2x)

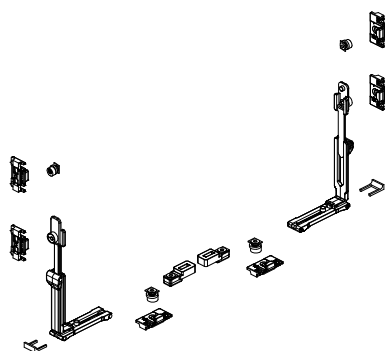

③

**Z 997455**

Basic kits for Top hung opening outward

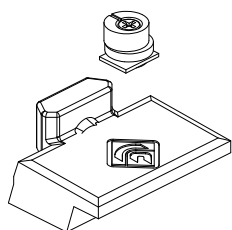

④

**Z 918507**

additional locking

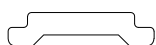

⑤

**K 910137**

Operating rod

Installation: refer to processing information

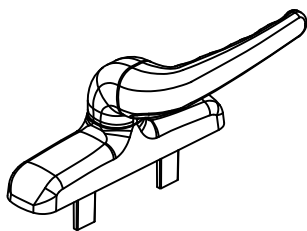

⑥ Z 997453

Grip handle for top hung window, right

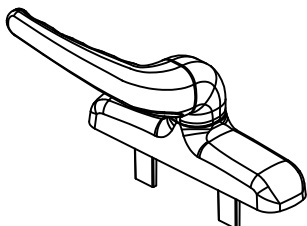

⑥ Z 997456

Grip handle for top hung window, left

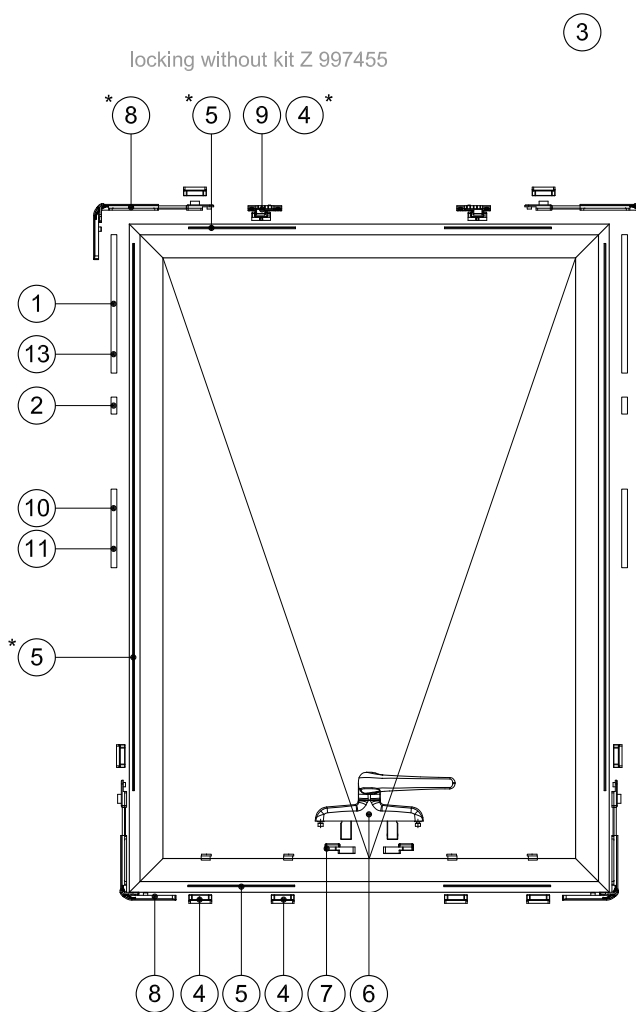
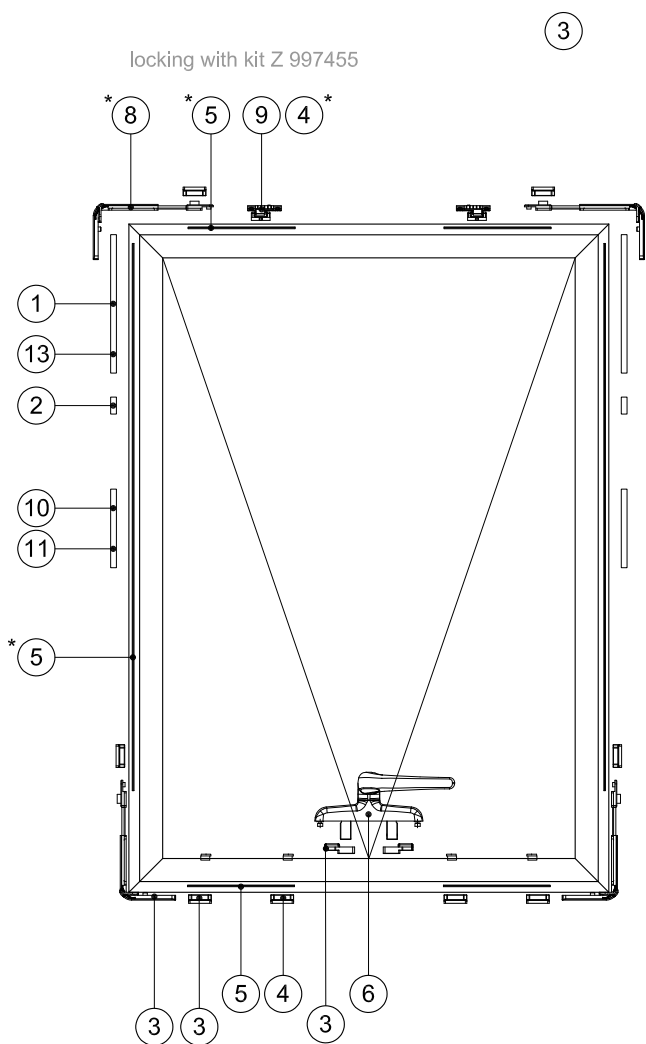

\* alternative locking mechanism with upper transmission corner

Installation: refer to Processing Information

102000200

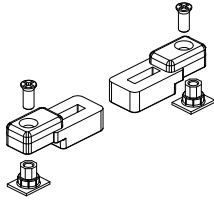

⑦ **Z 997452**

handle catch

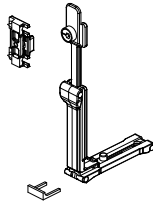

⑧ **Z 918508**

Transmission corner with strike plate

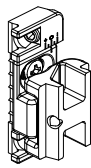

⑨ **Z 997424**

Additional locking point

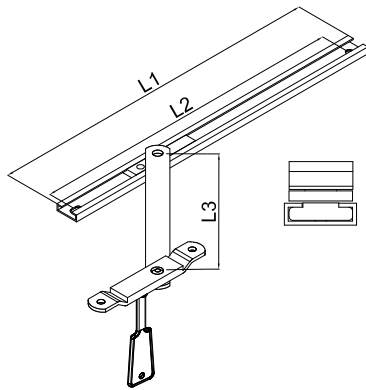

⑩

Art. no.	L (inch)	L1	L2	L3
<b>Z 997446</b>	6	150.5	131	85
<b>Z 997447</b>	8	201	184	152
<b>Z 997448</b>	10	254	236	180

Friction limiter arm  
with unlock key  
Packing unit (2x)

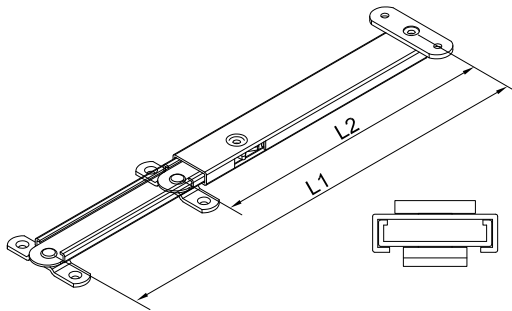

⑪

Art. no.	L (inch)	L1	L2
<b>Z 997449</b>	8	205	150
<b>Z 997450</b>	10	255	175
<b>Z 997451</b>	12	305	200

restrictor  
Packing unit (2x)



⑫ **Z 918611**

Unlock key



⑬ **Z 923133**

single limiter  
reduces the angle of 5°  
Packing unit (2x)

Installation: refer to Processing Information

1030003000



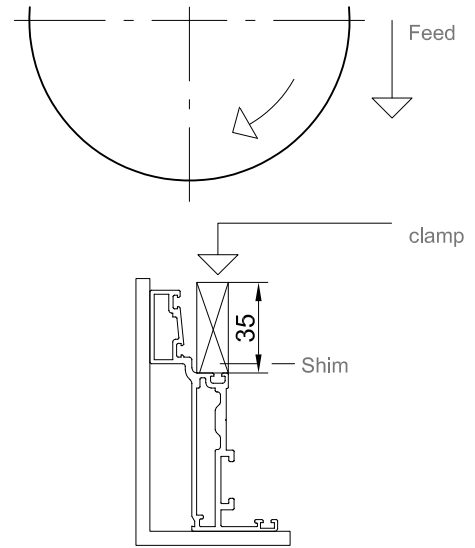
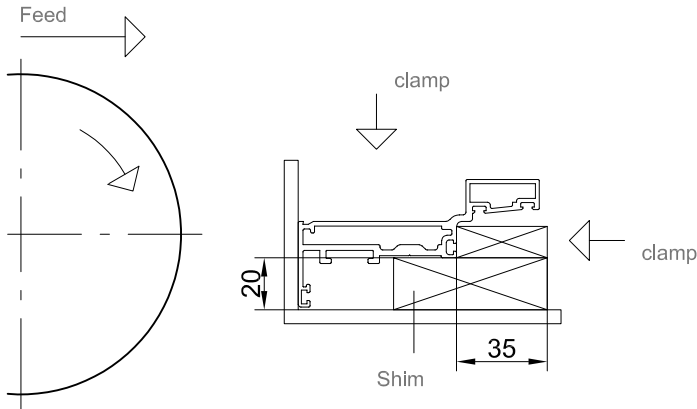

Elumatec

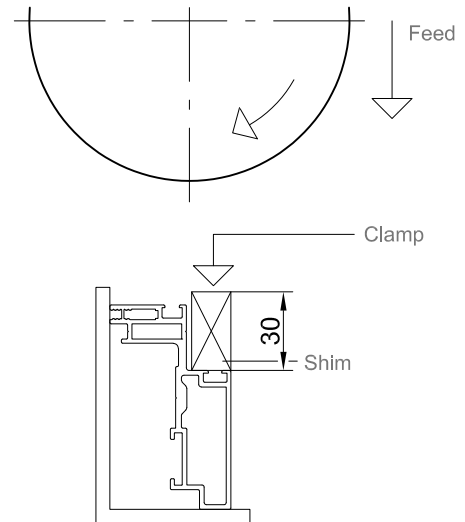
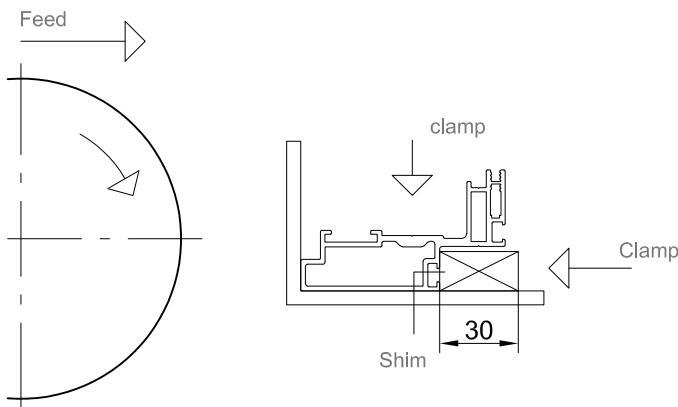
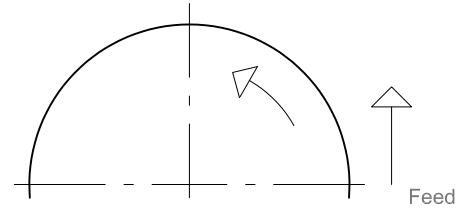
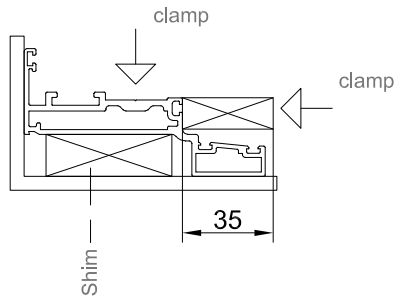

Elumatec

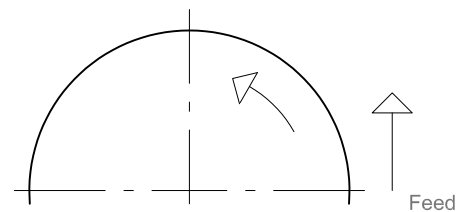
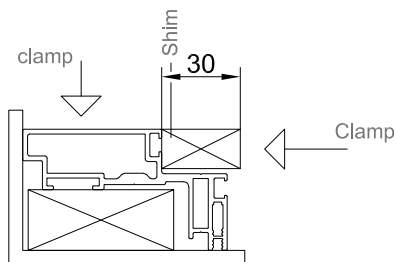

151002700

Trigon 50 / 60 NI

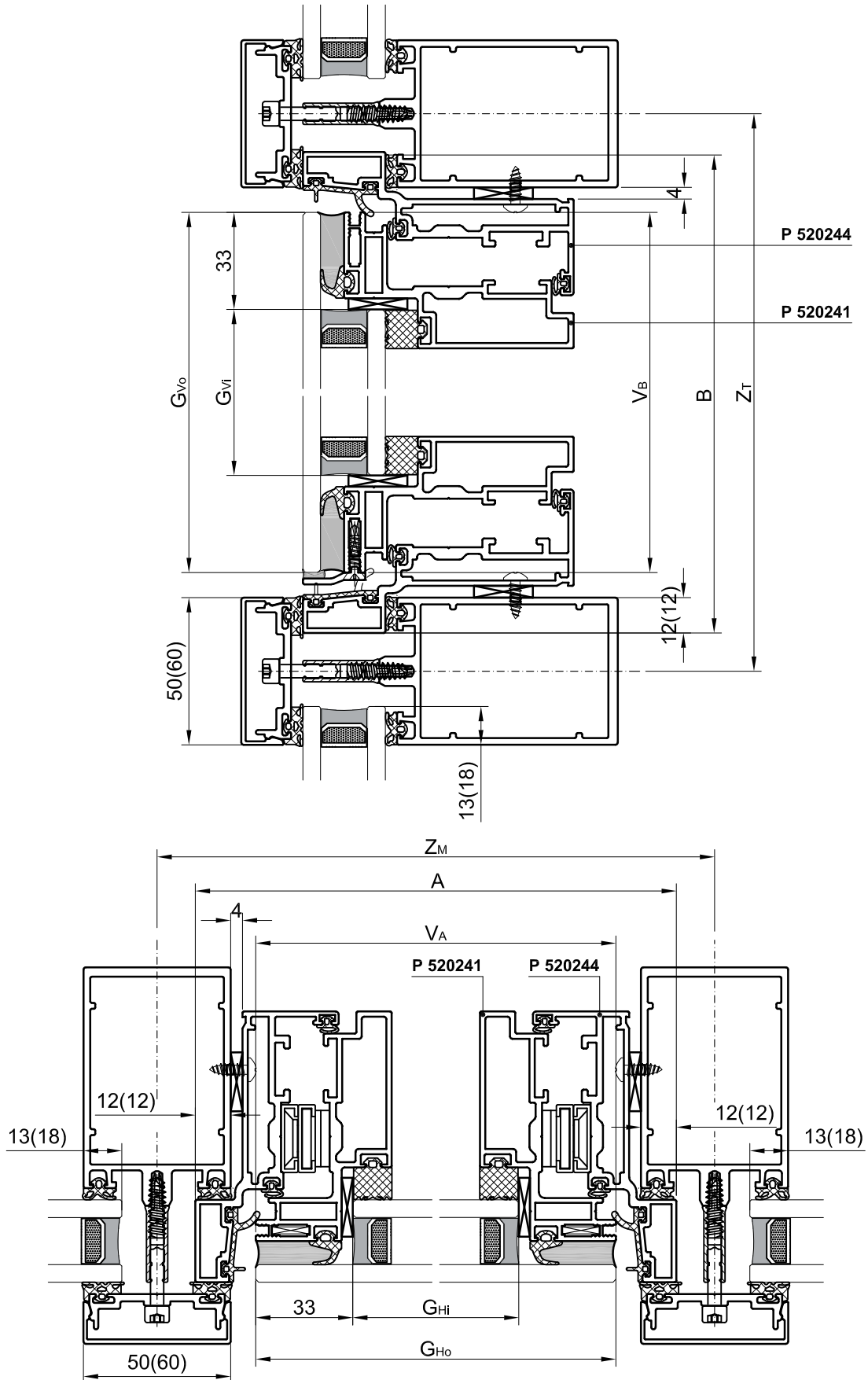

152002800



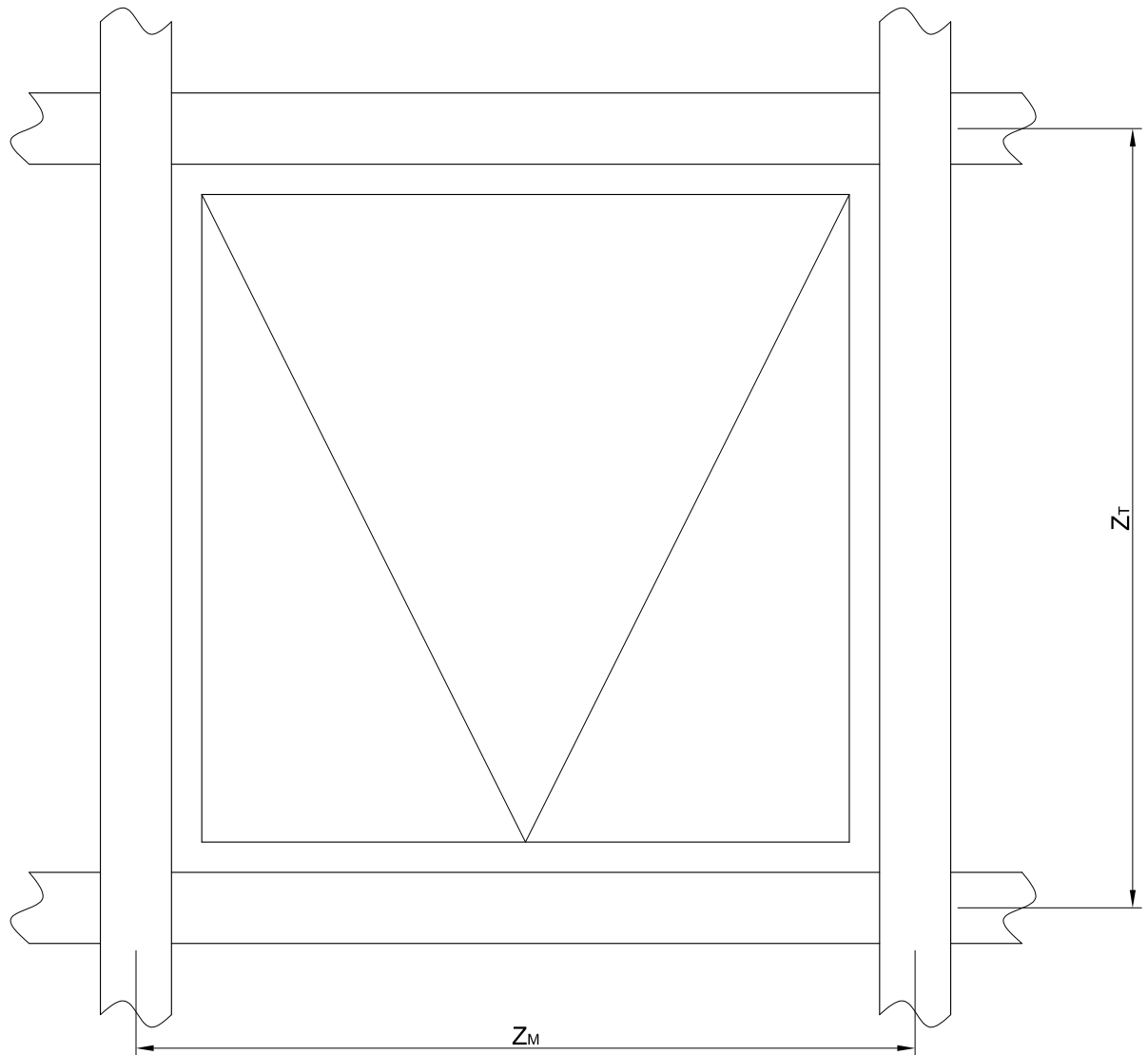

Trigon 50 NI (Standard)				
Descripton	Part no.	Calculation	Number	Cut
curtainwall horizontal		$Z_M = \text{axis dimension (mullions)}$	-	-
curtainwall vertical		$Z_T = \text{axis dimension (transoms)}$	-	-
frame horizontal	P 520244	$A = Z_M - 26$	2x	
frame vertical	P 520244	$B = Z_T - 26$	2x	
vent horizontal	P 520241	$V_A = A - 41$	2x	
vent vertical	P 520241	$V_B = B - 41$	2x	
Trigon 60 NI (Standard)				
Descripton	Part no.	Calculation	Number	Cut
curtainwall horizontal		$Z_M = \text{axis dimension (mullions)}$	-	-
curtainwall vertical		$Z_T = \text{axis dimension (transoms)}$	-	-
frame horizontal	P 520244	$A = Z_M - 36$	2x	
frame vertical	P 520244	$B = Z_T - 36$	2x	
vent horizontal	P 520241	$V_A = A - 41$	2x	
vent vertical	P 520241	$V_B = B - 41$	2x	

153000300

Trigon 50 (SG) NI

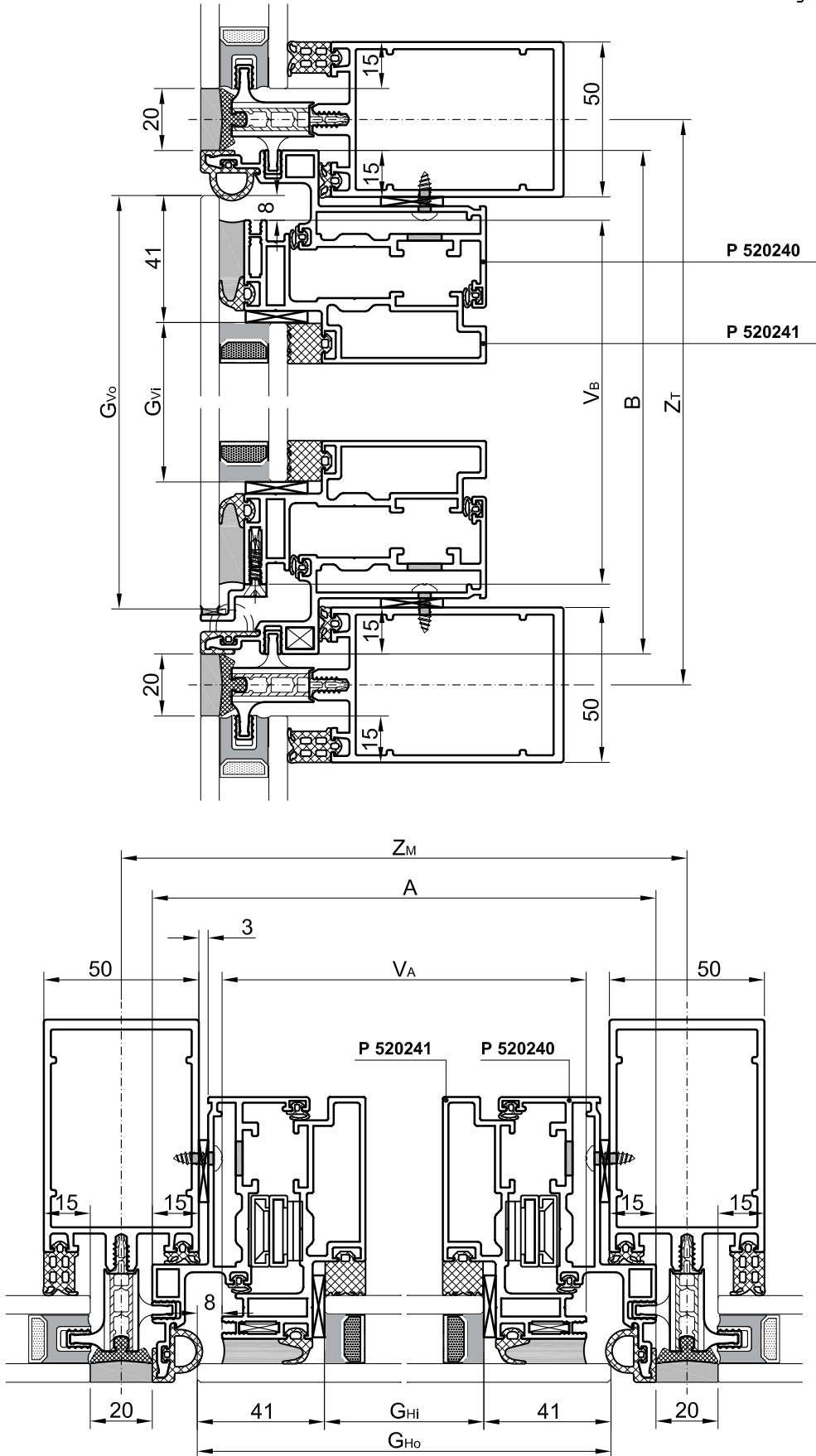

154003000

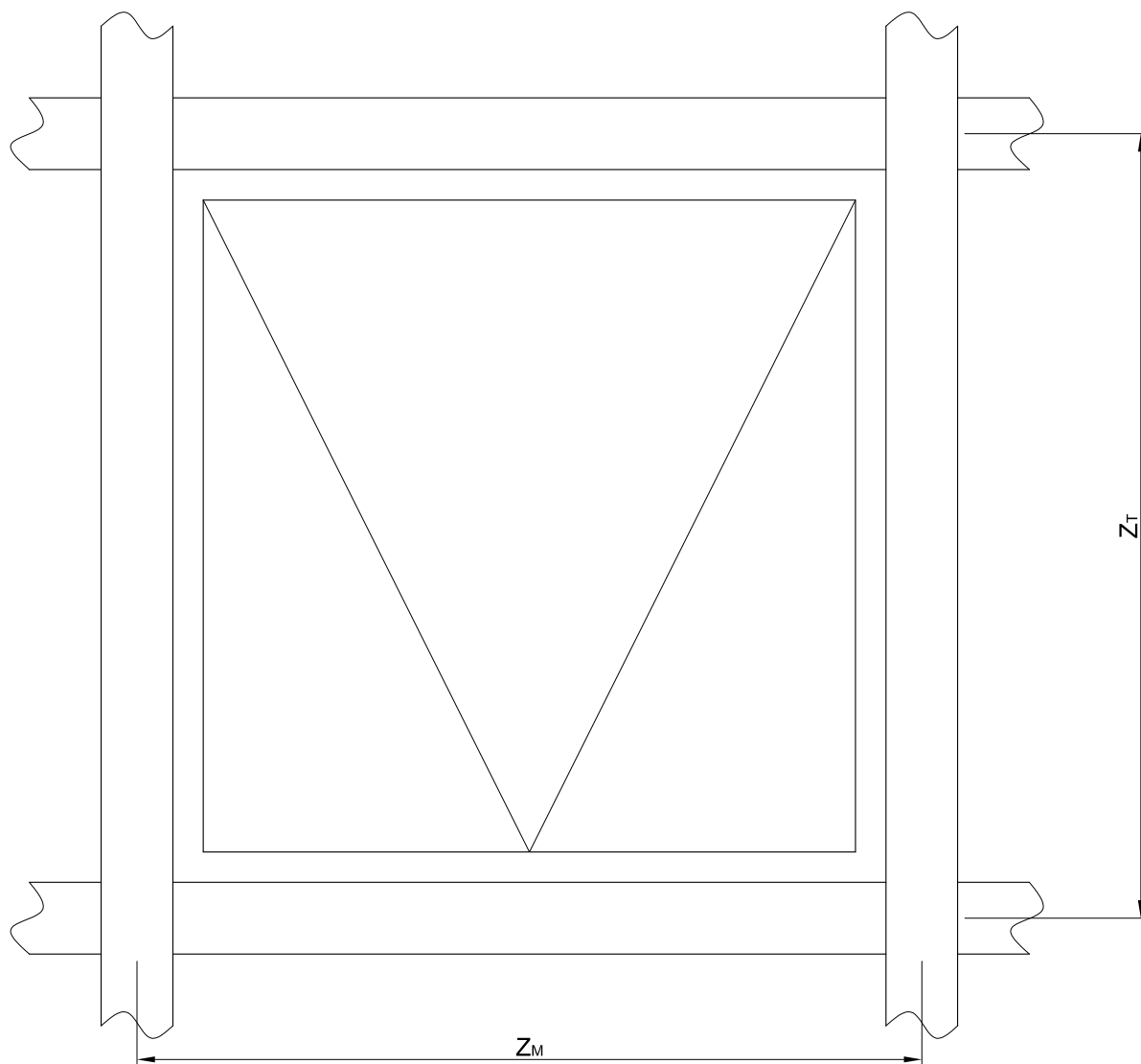

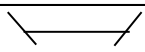
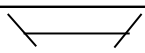
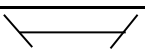
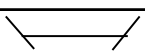
Trigon 50 (SG) NI				
Descritpion	Part no.	Calculation	Number	Cut
curtainwall horizontal		$Z_M = \text{axis dimensions (mullions)}$	-	-
curtainwall vertical		$Z_T = \text{axis dimensions (transoms)}$	-	-
frame horizontal	P 520240	$A = Z_M - 20$	2x	
frame vertical	P 520240	$B = Z_T - 20$	2x	
vent horizontal	P 520241	$V_A = A - 45$	2x	
vent vertical	P 520241	$V_B = B - 45$	2x	

155000600

Trigon 60 (SG) NI

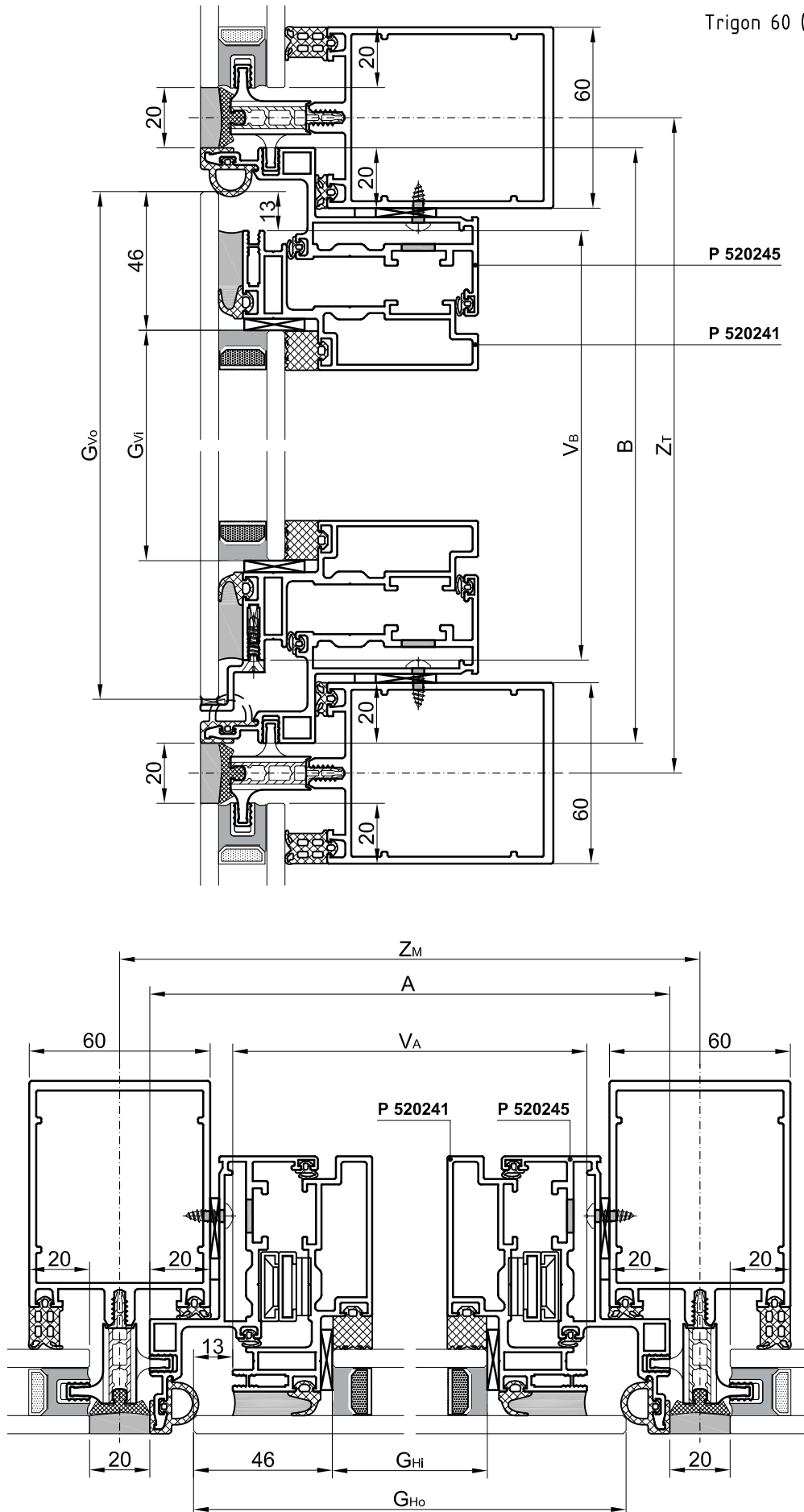

156003200

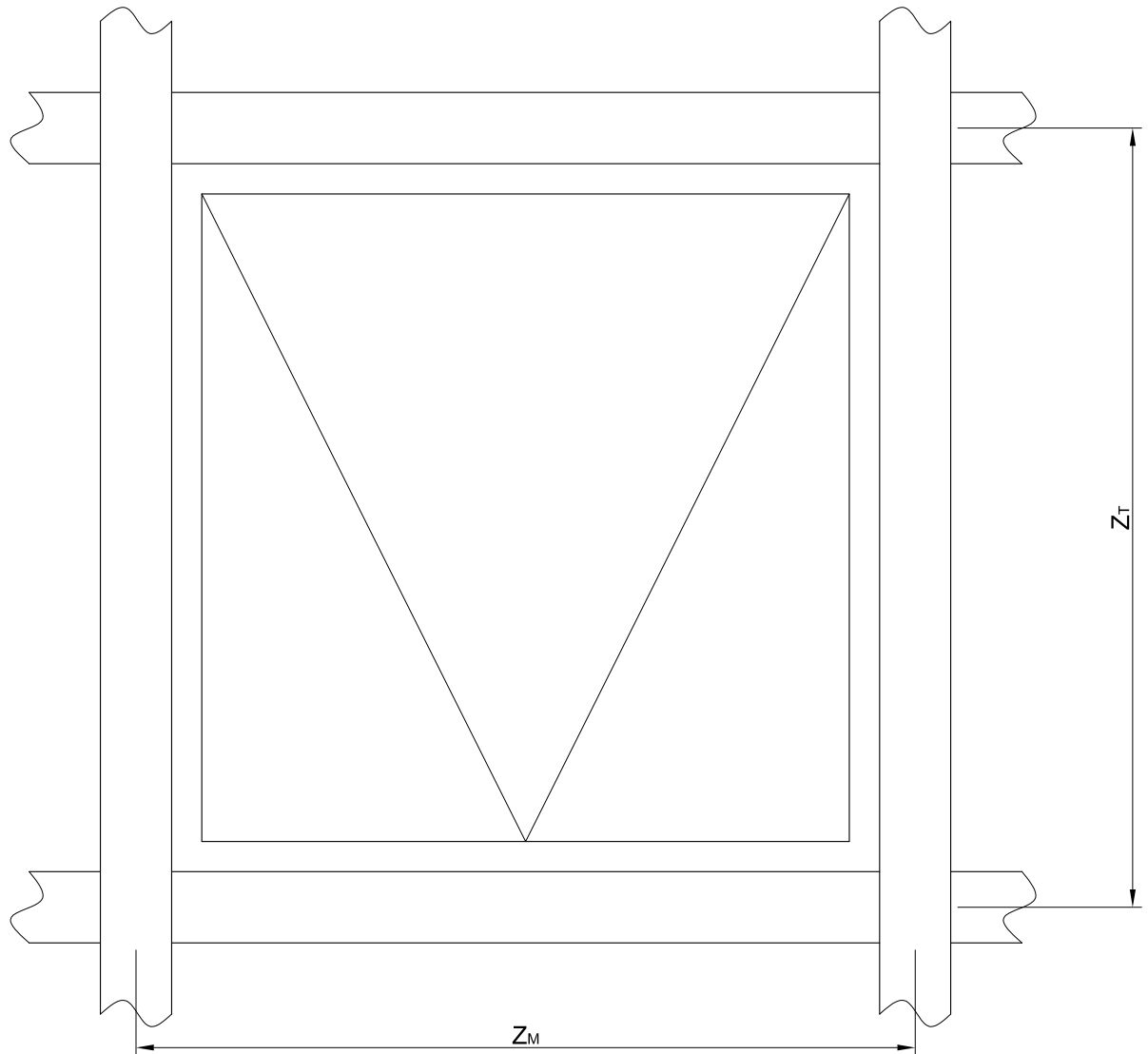

Trigon 60 (SG) NI				
Descritpion	Part no.	Calculation	Number	Cut
curtainwall horizontal		$Z_M = \text{axis dimensions (mullions)}$	-	-
curtainwall vertical		$Z_T = \text{axis dimensions (transoms)}$	-	-
frame horizontal	P 520245	$A = Z_M - 20$	2x	
frame vertical	P 520245	$B = Z_T - 20$	2x	
vent horizontal	P 520241	$V_A = A - 55$	2x	
vent vertical	P 520241	$V_B = B - 55$	2x	

157000700



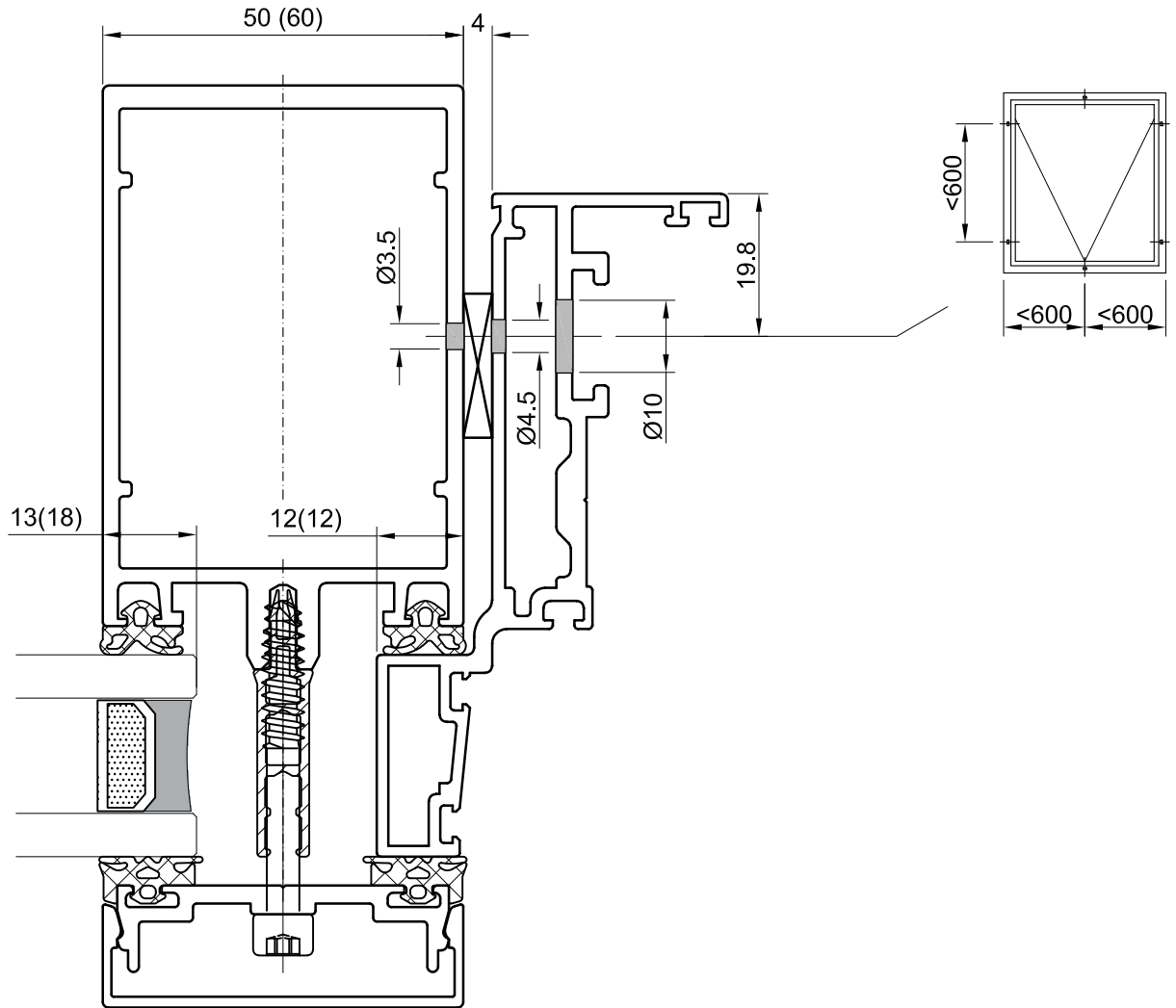

159003500

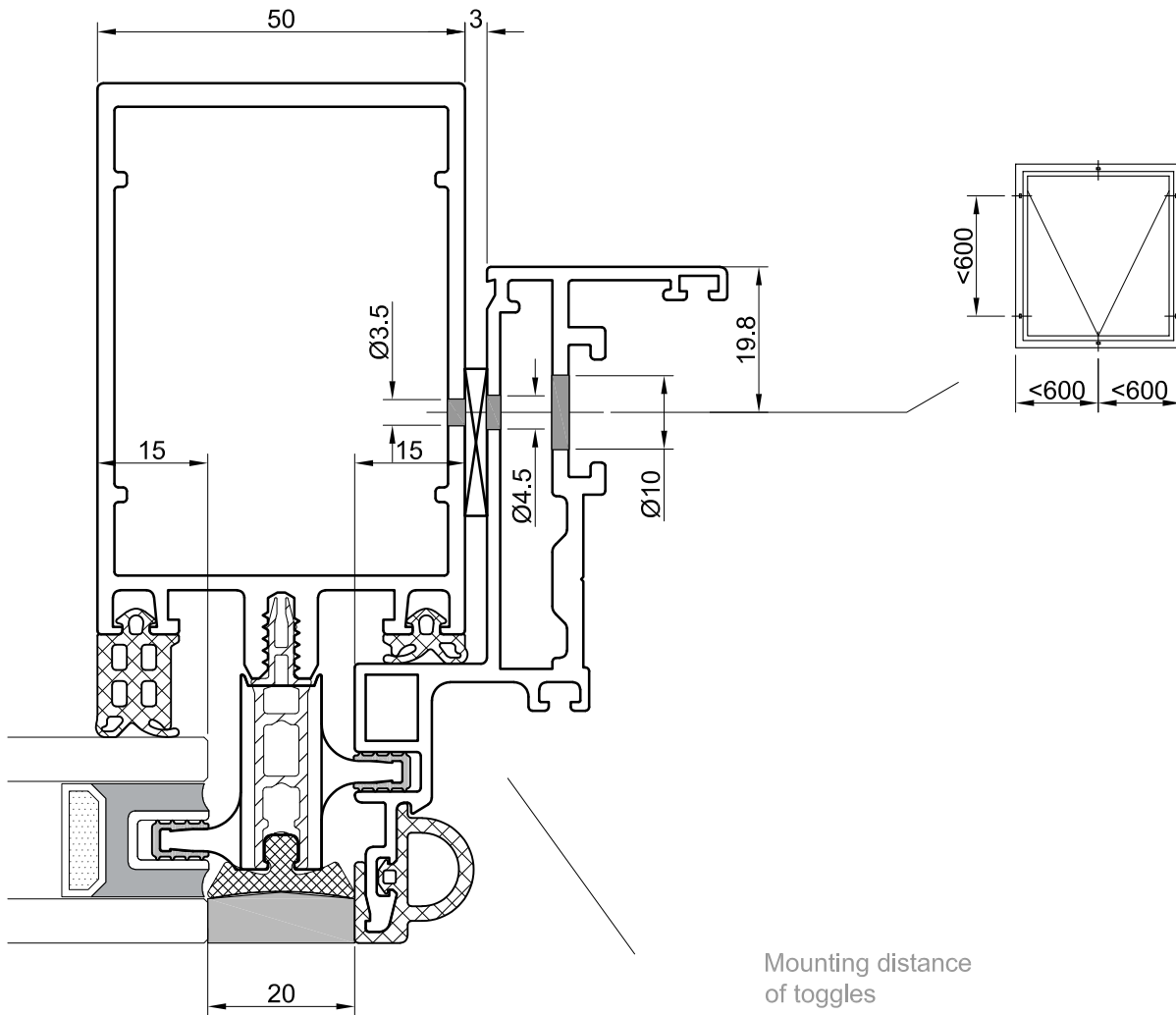

Mounting distance  
of toggles

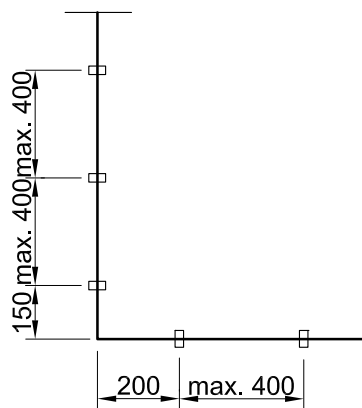



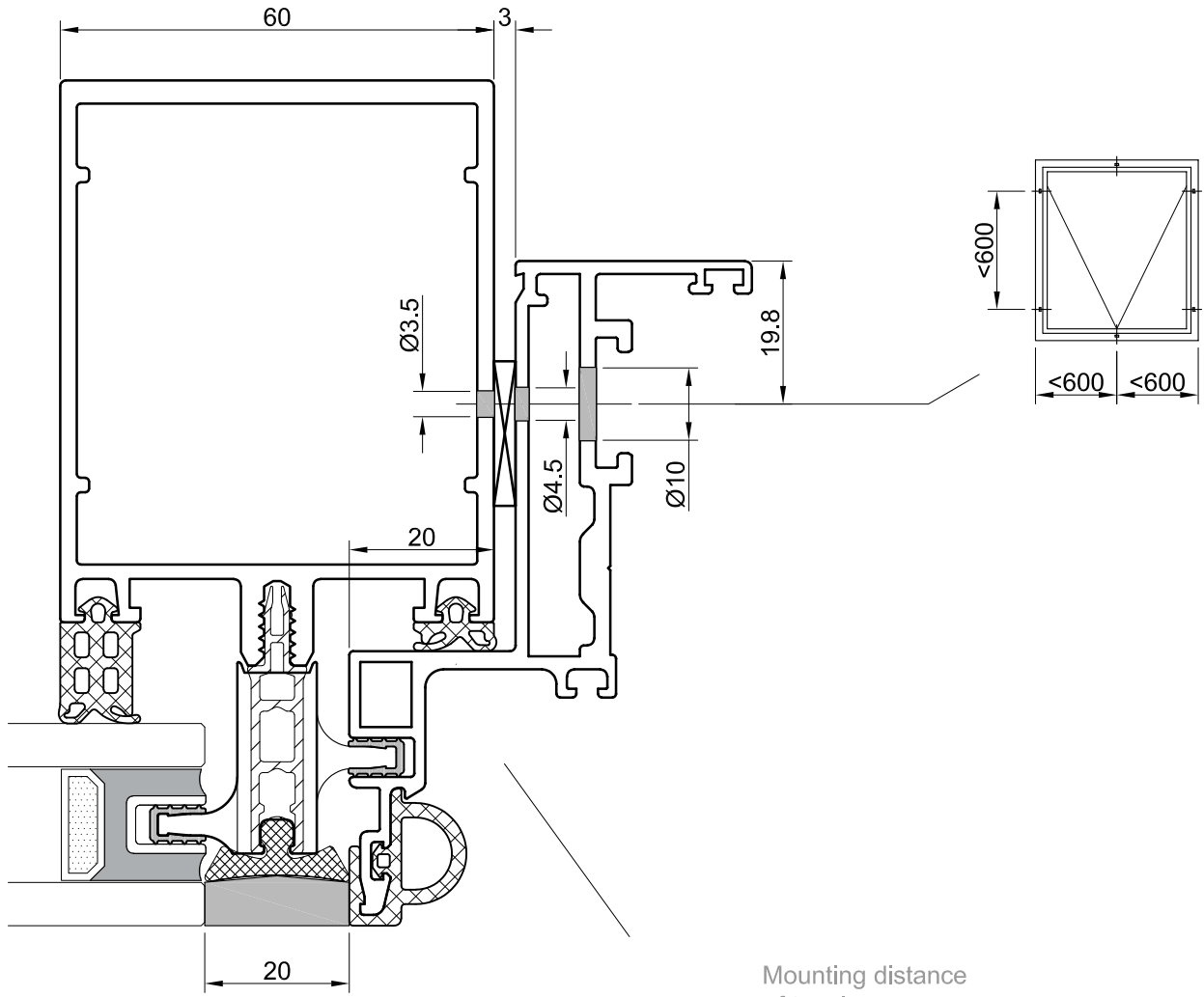

Mounting distance of toggles

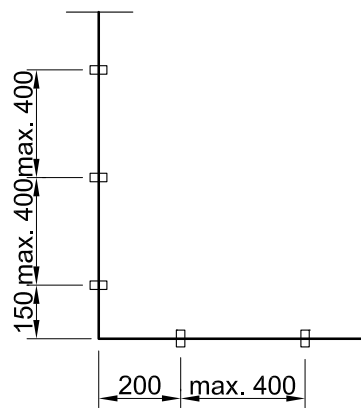

161003700

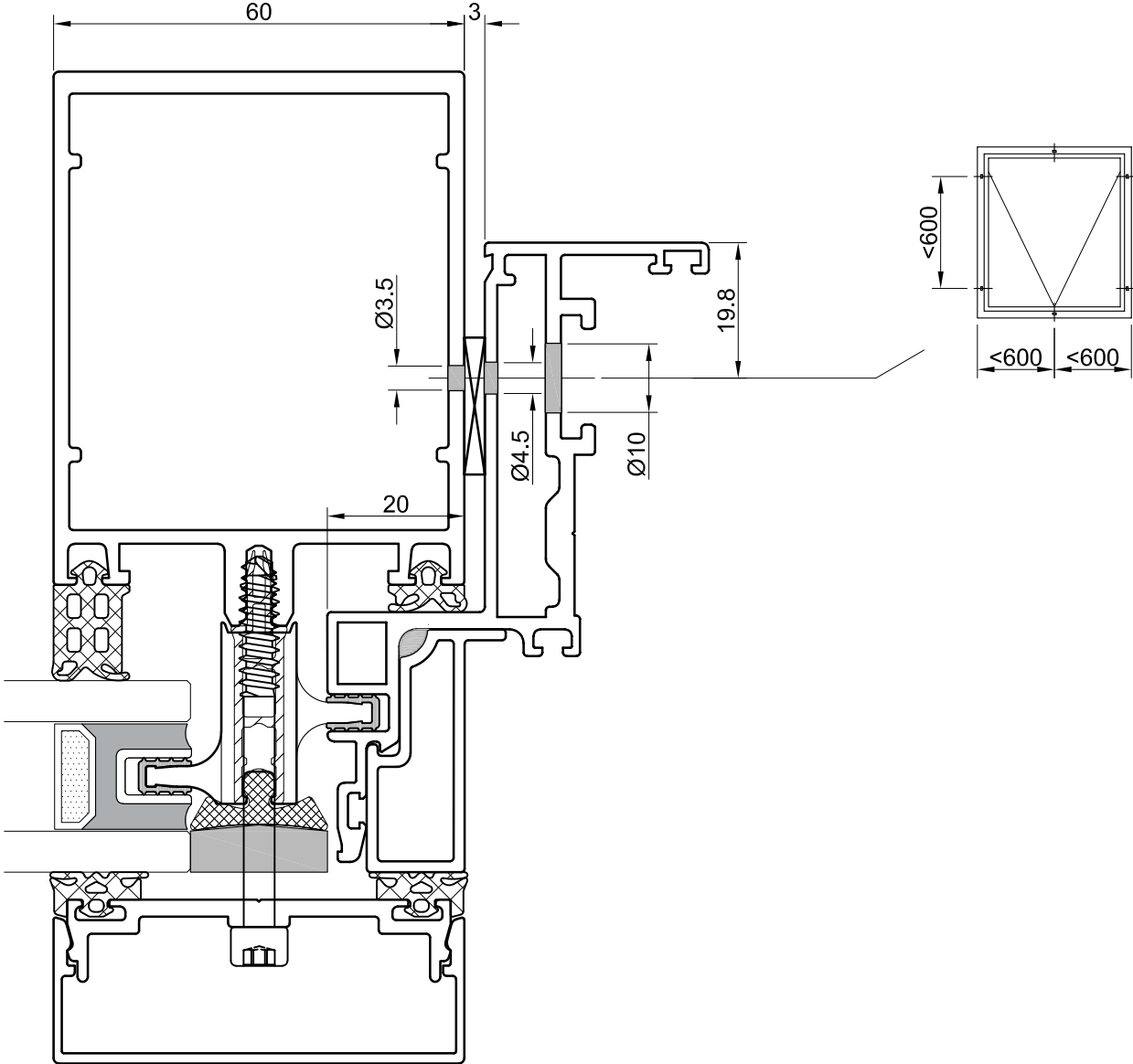

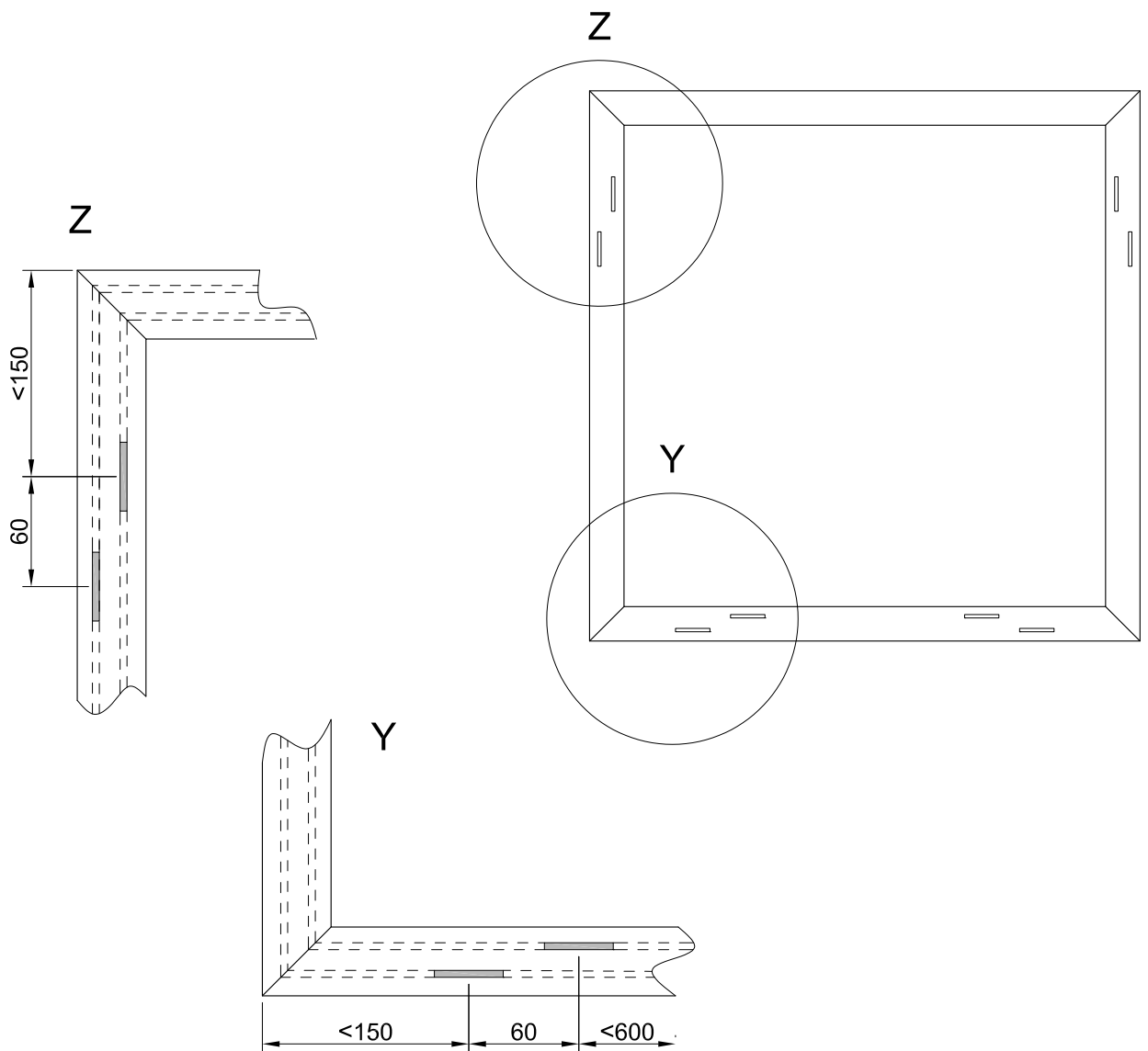
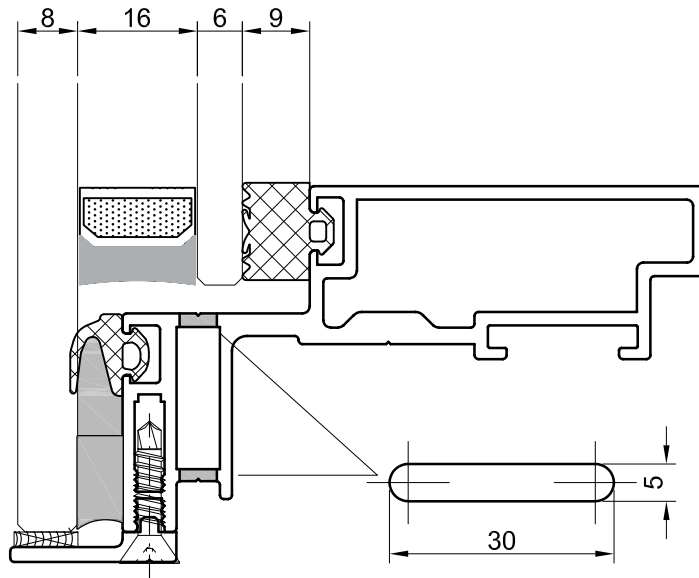

163003800

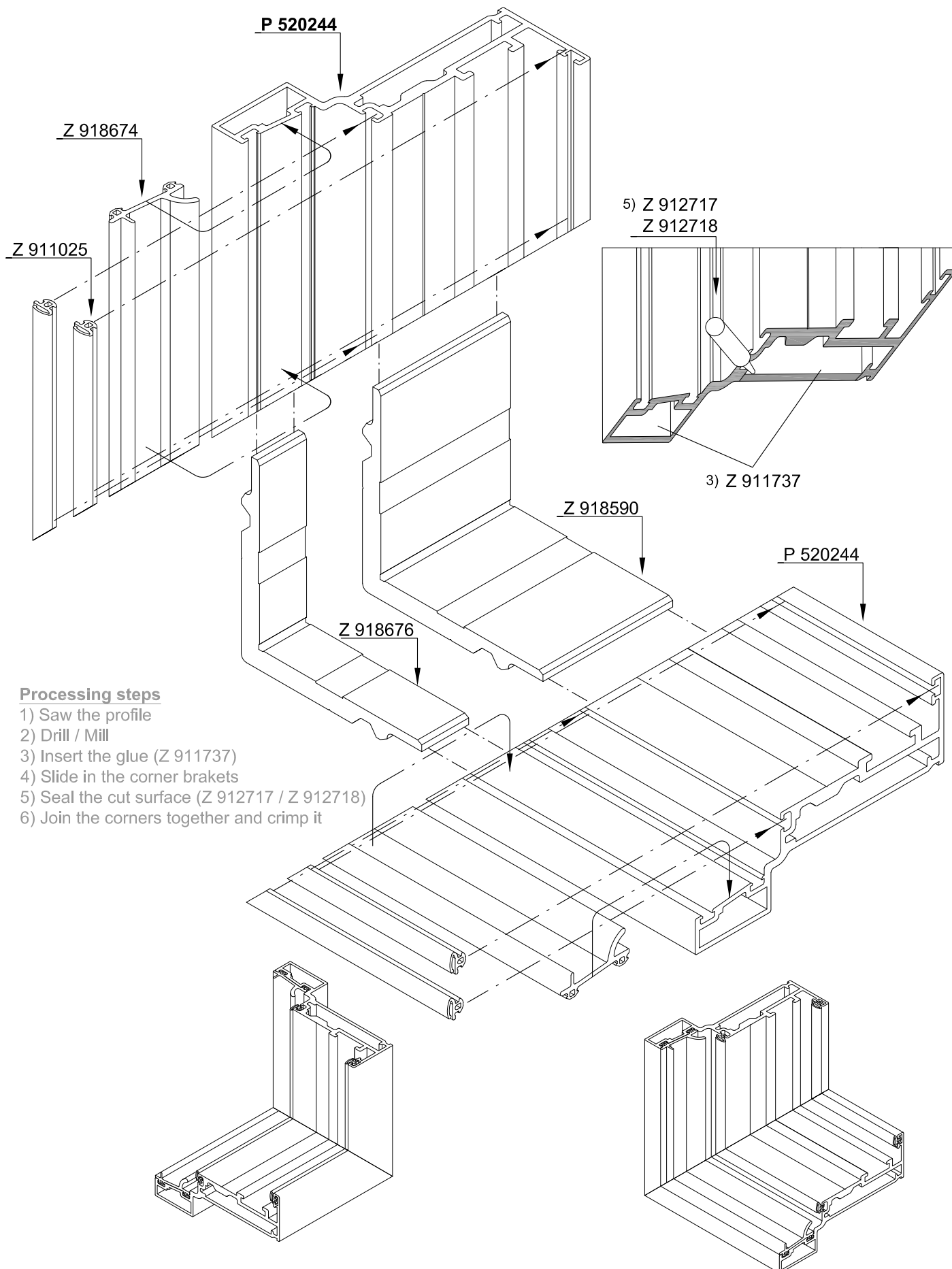

### Processing steps

- 1) Saw the profile
- 2) Drill / Mill
- 3) Insert the glue (Z 911737)
- 4) Slide in the corner brackets
- 5) Seal the cut surface (Z 912717 / Z 912718)
- 6) Join the corners together and crimp it

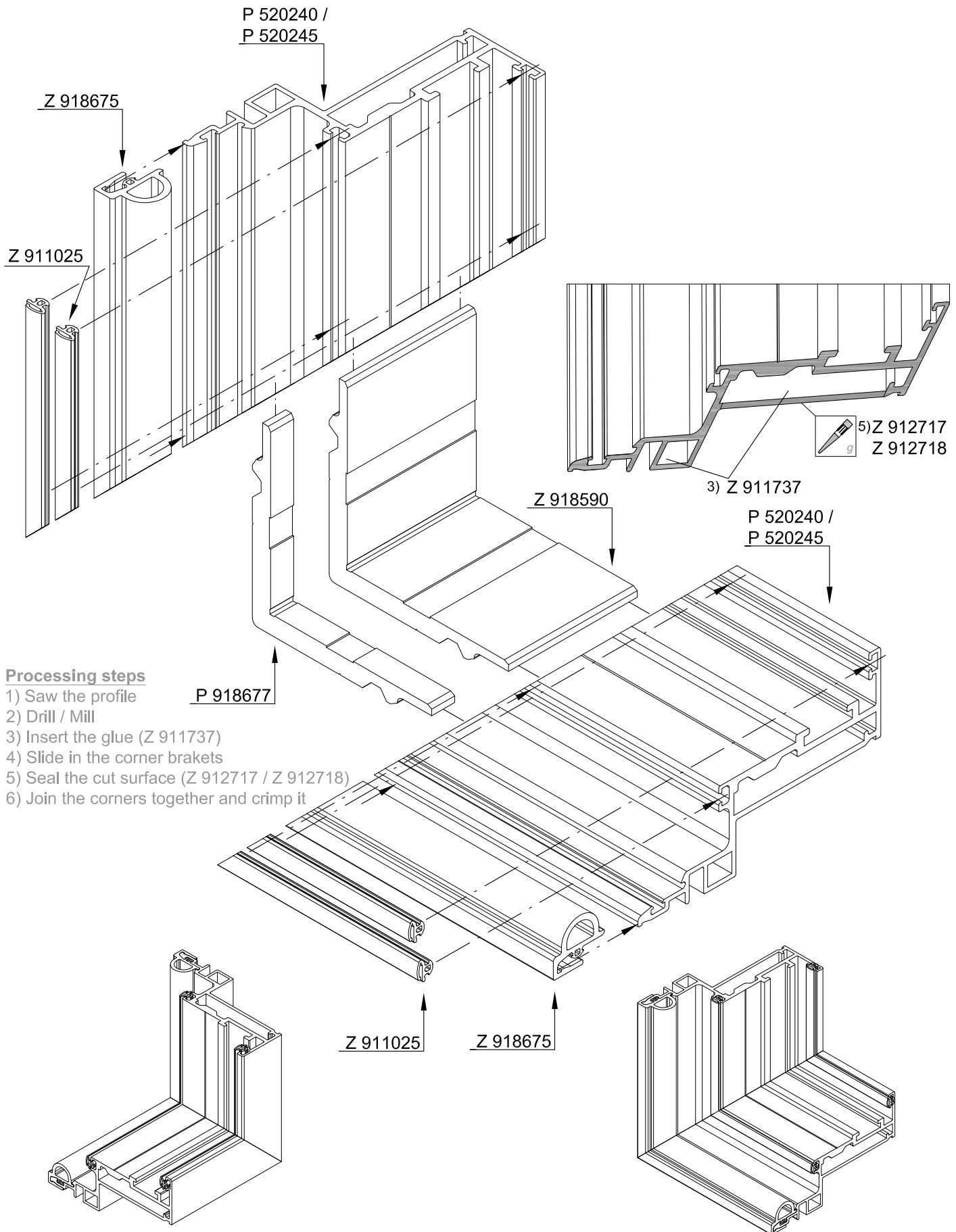

165001400

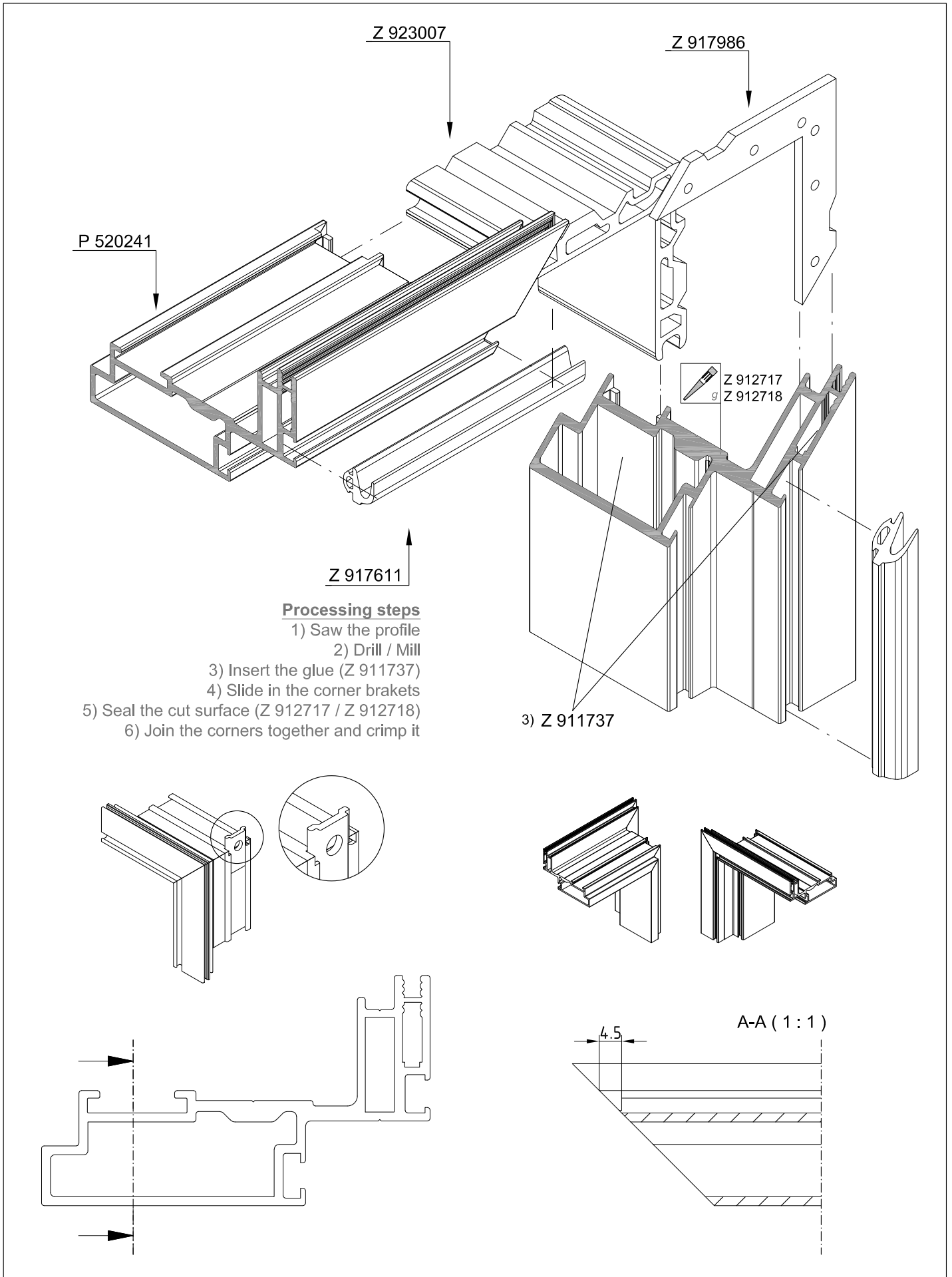

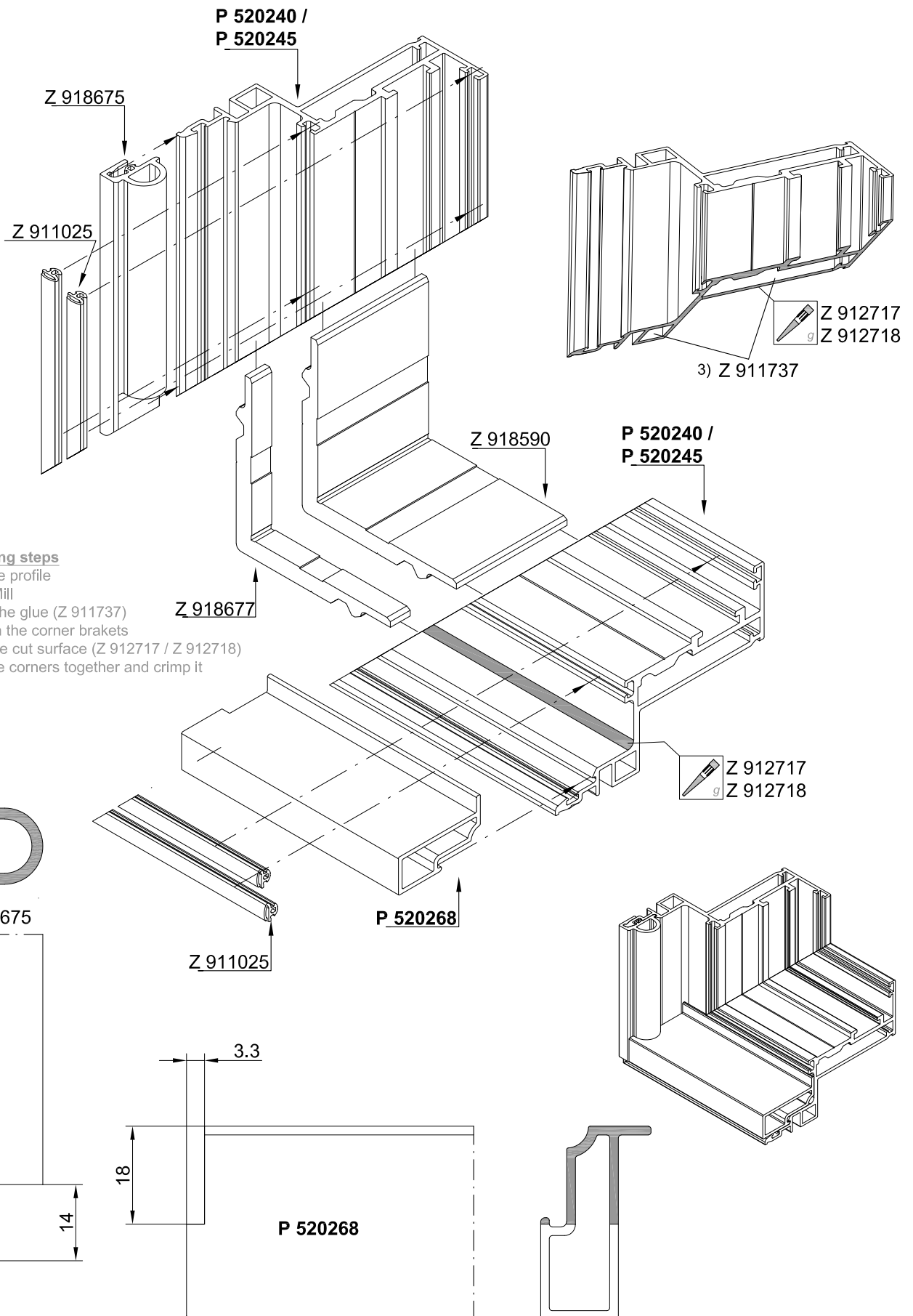

- Fixing of glass supports P 420246, P 420247 and P 420260 -

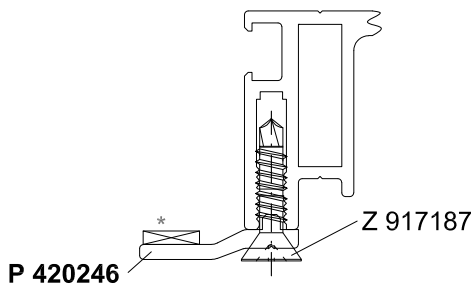
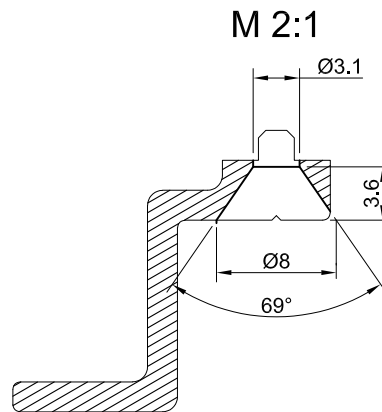
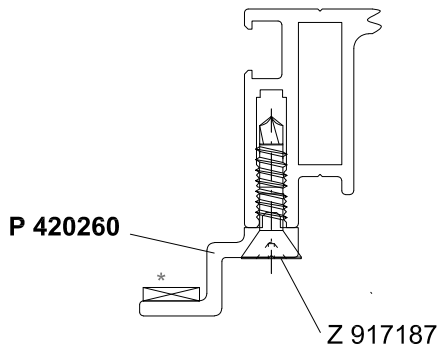
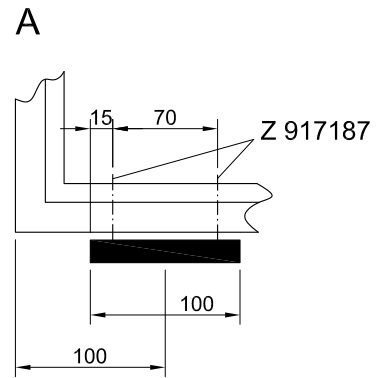
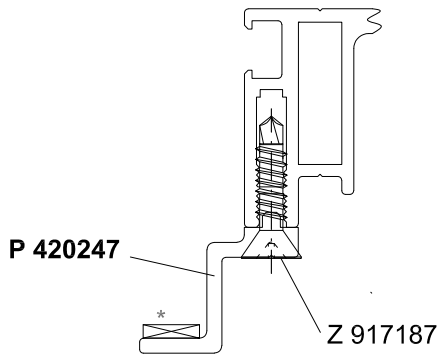
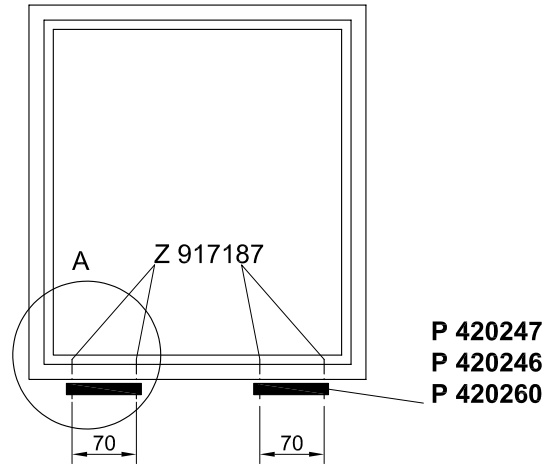
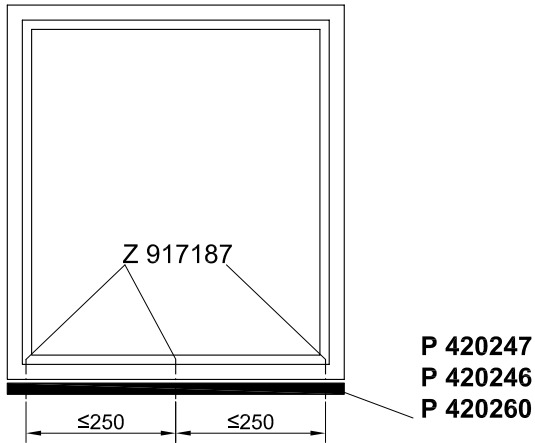

\* choose required glazing block depending on glass tolerances



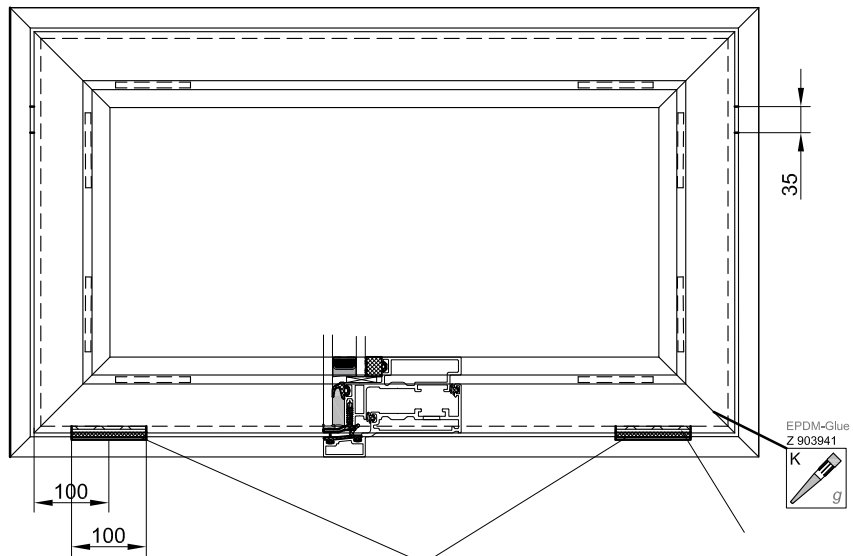

1) cutting of the gasket Z 918674 in the area of the edge protection

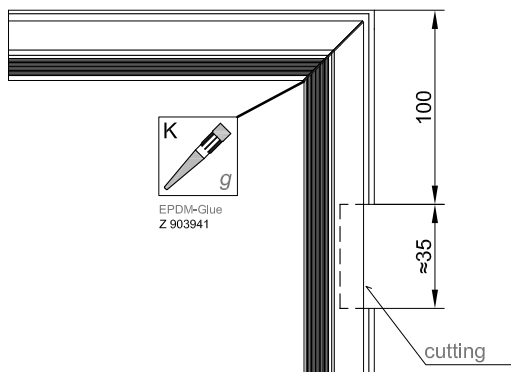
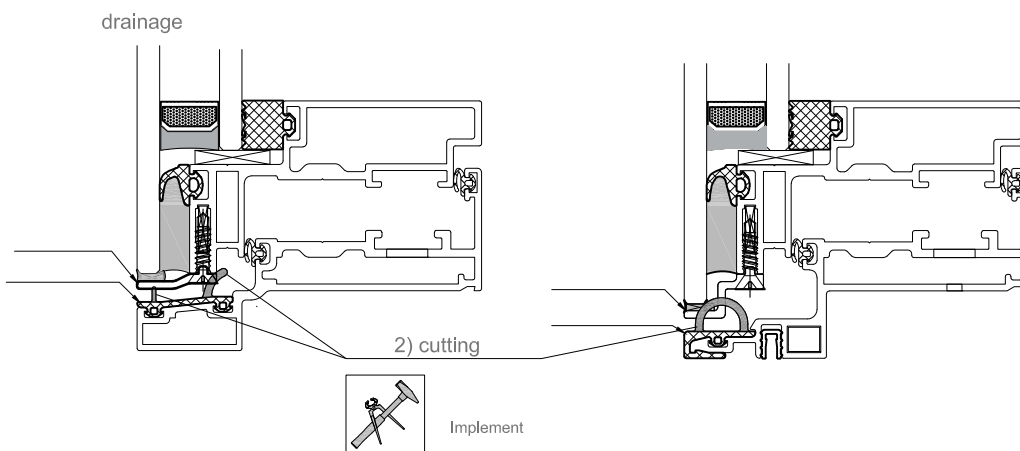

169002700

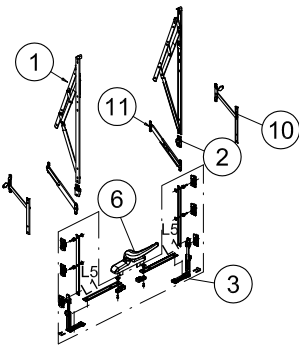
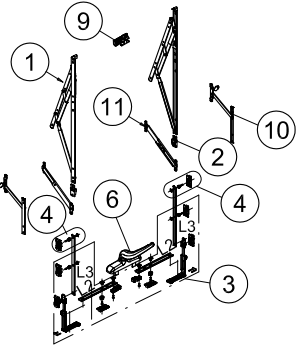
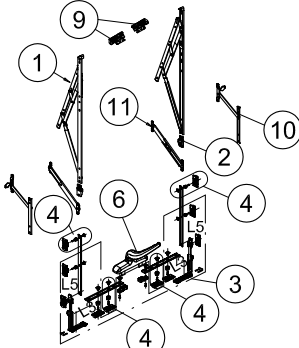
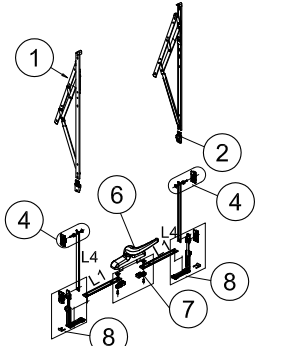
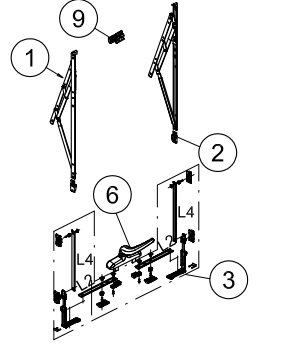
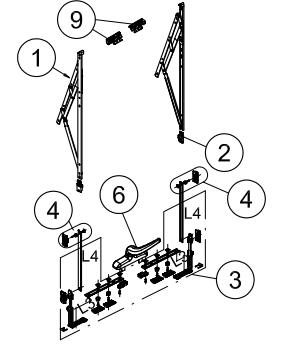
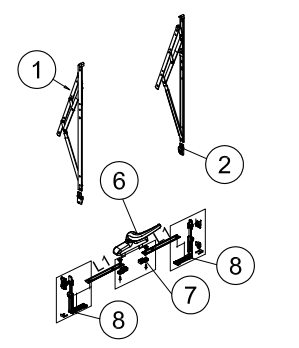
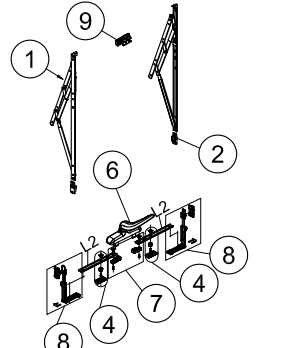
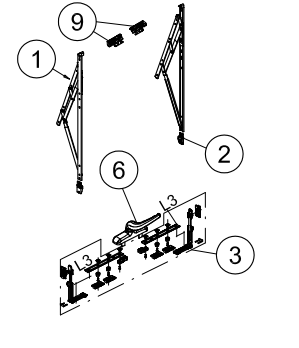
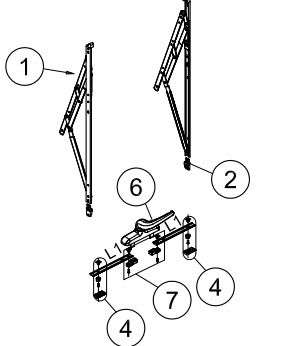
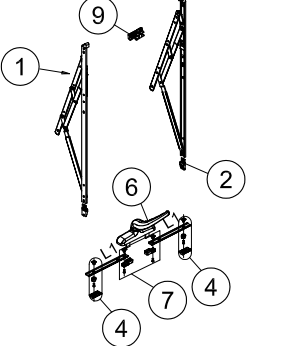
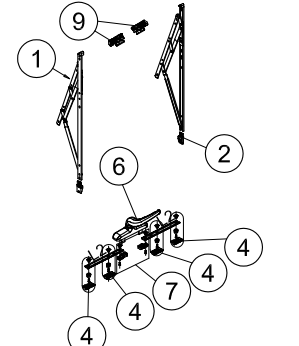

height	2000	 <ul style="list-style-type: none"> <li>1 cf. stay- hinge table</li> <li>2 Z 914455</li> <li>3 Z 997455</li> <li>6 Z 997453/ Z997456</li> <li>10 cf. friction limiter arm table</li> <li>or</li> <li>11 cf. telescopic limiter arm table</li> </ul>	 <ul style="list-style-type: none"> <li>1 cf. stay- hinge table</li> <li>2 Z 914455</li> <li>3 Z 997455</li> <li>4 Z 918507 2x</li> <li>6 Z 997453/ Z997456</li> <li>9 Z 997424</li> <li>10 cf. friction limiter arm table</li> <li>or</li> <li>11 cf. telescopic limiter arm table</li> </ul>	 <ul style="list-style-type: none"> <li>1 cf. stay- hinge table</li> <li>2 Z 914455</li> <li>3 Z 997455</li> <li>4 Z 918507 4x</li> <li>6 Z 997453/ Z997456</li> <li>9 Z 997424 2x</li> <li>10 cf. friction limiter arm table</li> <li>or</li> <li>11 cf. telescopic limiter arm table</li> </ul>
	1499	 <ul style="list-style-type: none"> <li>1 cf. stay- hinge table</li> <li>2 Z 914455</li> <li>4 Z 918507 2x</li> <li>6 Z 997453/ Z997456</li> <li>7 Z 997452</li> <li>8 Z 918508 2x</li> </ul>	 <ul style="list-style-type: none"> <li>1 cf. stay- hinge table</li> <li>2 Z 914455</li> <li>3 Z 997455</li> <li>6 Z 997453/ Z997456</li> <li>9 Z 997424</li> </ul>	 <ul style="list-style-type: none"> <li>1 cf. stay- hinge table</li> <li>2 Z 914455</li> <li>3 Z 997455</li> <li>4 Z 918507 2x</li> <li>6 Z 997453/ Z997456</li> <li>9 Z 997424 2x</li> </ul>
	1199	 <ul style="list-style-type: none"> <li>1 cf. stay- hinge table</li> <li>2 Z 914455</li> <li>6 Z 997453/ Z997456</li> <li>7 Z 997452</li> <li>8 Z 918508 2x</li> </ul>	 <ul style="list-style-type: none"> <li>1 cf. stay- hinge table</li> <li>2 Z 914455</li> <li>4 Z 918507 2x</li> <li>6 Z 997453/ Z997456</li> <li>7 Z 997452</li> <li>8 Z 918508 2x</li> <li>9 Z 997424</li> </ul>	 <ul style="list-style-type: none"> <li>1 cf. stay- hinge table</li> <li>2 Z 914455</li> <li>3 Z 997455</li> <li>6 Z 997453/ Z997456</li> <li>9 Z 997424 2x</li> </ul>
	799	 <ul style="list-style-type: none"> <li>1 cf. stay- hinge table</li> <li>2 Z 914455</li> <li>4 Z 918507 2x</li> <li>6 Z 997453/ Z997456</li> <li>7 Z 997452</li> </ul>	 <ul style="list-style-type: none"> <li>1 cf. stay- hinge table</li> <li>2 Z 914455</li> <li>4 Z 918507 2x</li> <li>6 Z 997453/ Z997456</li> <li>7 Z 997452</li> <li>9 Z 997424</li> </ul>	 <ul style="list-style-type: none"> <li>1 cf. stay- hinge table</li> <li>2 Z 914455</li> <li>4 Z 918507 4x</li> <li>6 Z 997453/ Z997456</li> <li>7 Z 997452</li> <li>9 Z 997424 2x</li> </ul>

1	stay- hinge table Z 997435 Z 997436 Z 997437 Z 997438 Z 997439 Z 997440 Z 997441 Z 997442 Z 997443
2	Z 914455
3	Z 997455
4	Z 918507
5	K 910137
6	Z 997453/ Z997456

7	Z 997452
8	Z 918508
9	Z 997424
10	friction limiter arm table Z 997446 Z 997447 Z 997448
11	telescopic limiter arm table Z 997449 Z 997450 Z 997451

L4 - Rod machining for vertical locking points

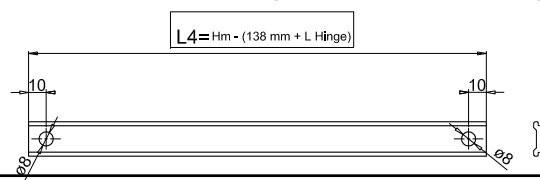

L5 - Rod machining for vertical locking points

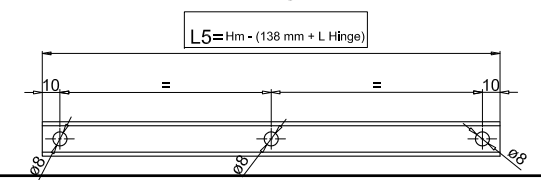

L1 - Machining for cremone rod and horizontal locking points

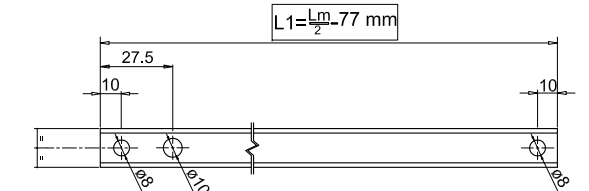

L2 - Machining for cremone rod and horizontal locking points

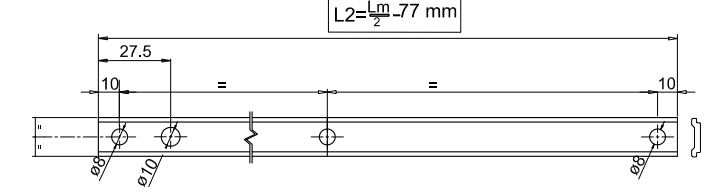

L3 - Machining for cremone rod and horizontal locking points

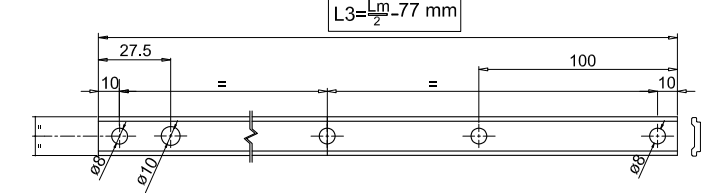

- ① cf. stay- hinge table
- ② Z 997444
- ③ Z 997455
- ④ Z 918507 4x
- ⑥ Z 997453/ Z997456
- ⑨ Z 997424 2x
- ⑩ cf. friction limiter arm table
- or
- ⑪ cf. telescopic limiter arm table

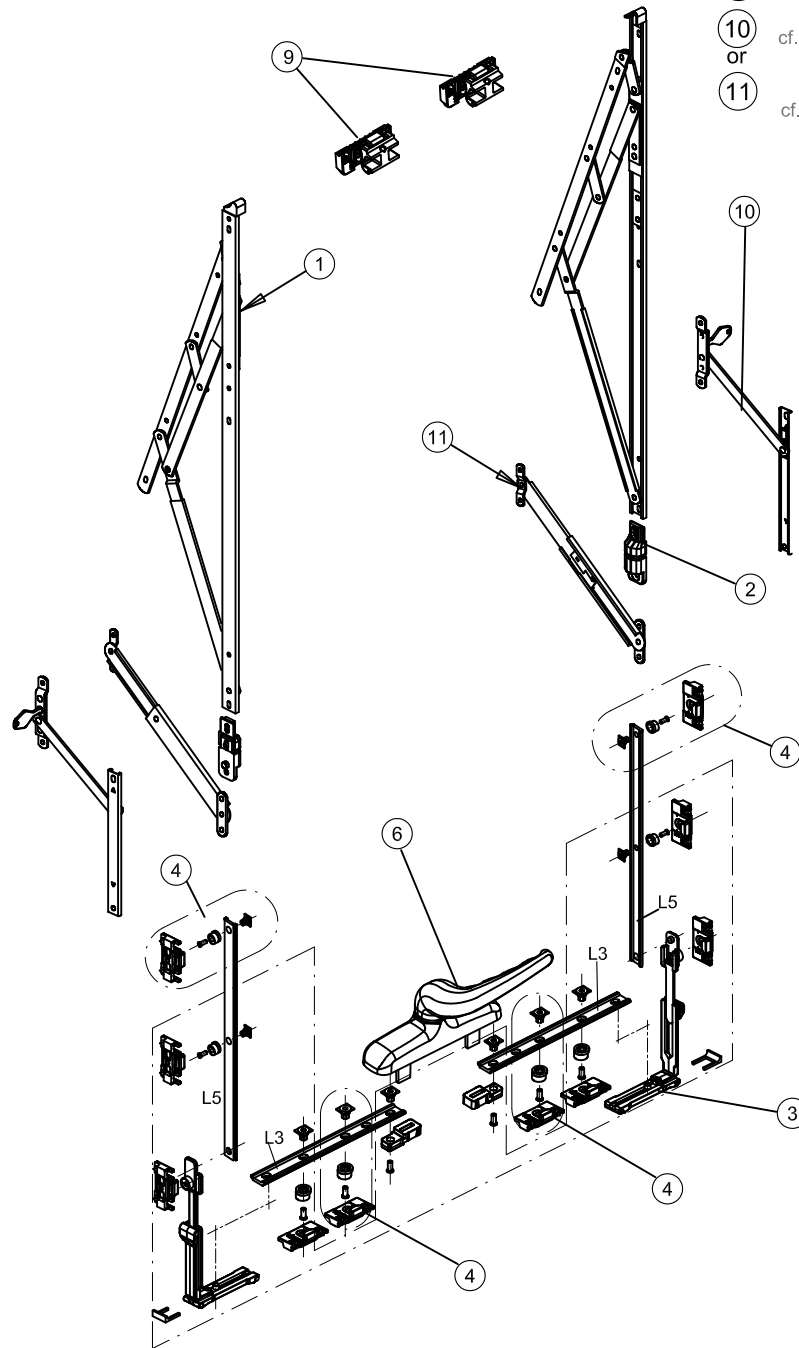

locking mechanism without upper transmission corner

- ① cf. stay- hinge table
- ② Z 997444
- ③ Z 997455
- ④ Z 918507 6x
- ⑥ Z 997453/ Z997456
- ⑧ Z 918508
- ⑨ Z 997424 2x
- ⑩ cf. friction limiter arm table
- or
- ⑪ cf. telescopic limiter arm table

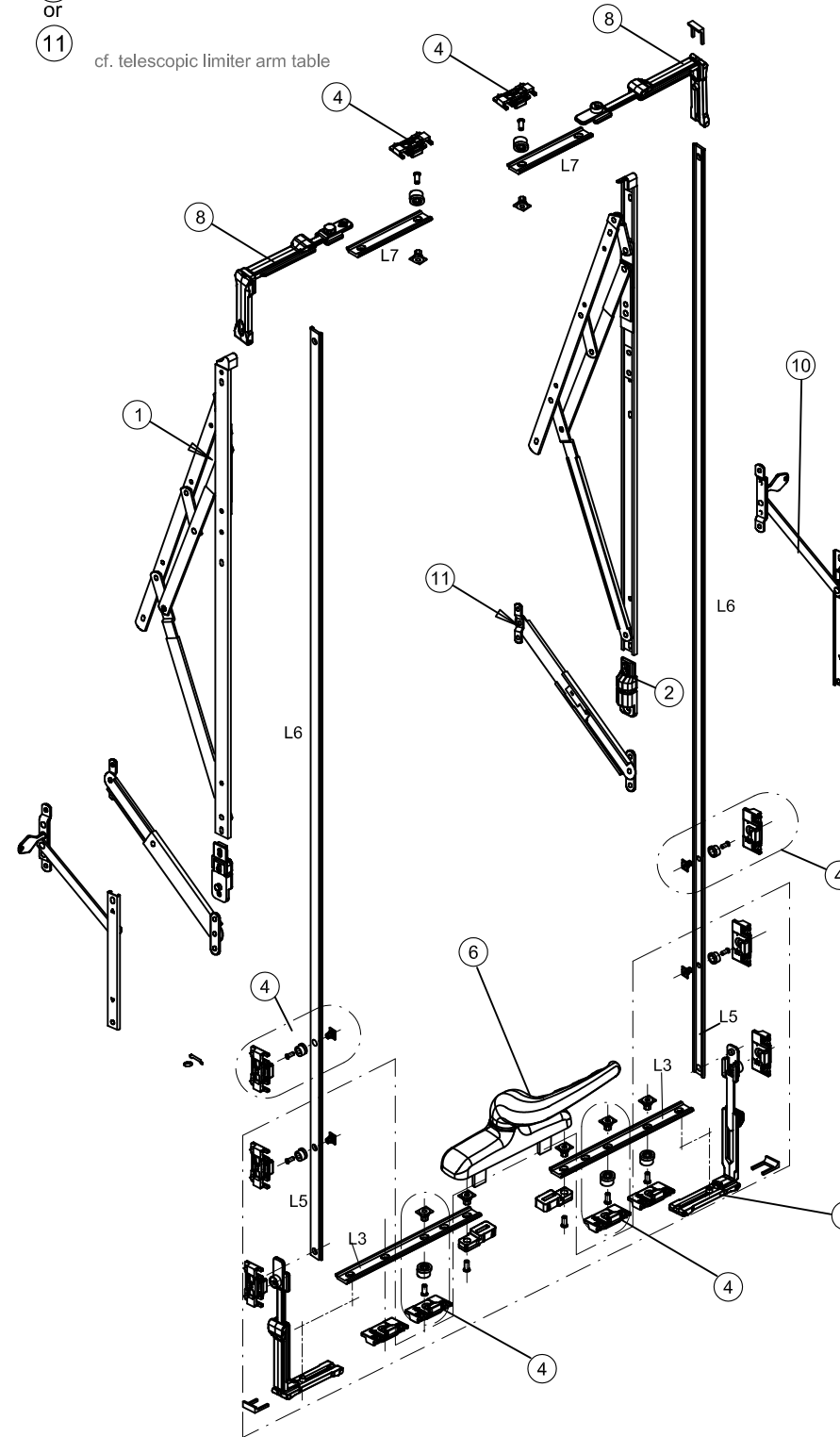

alternative locking mechanism with upper transmission corner

L4 - Rod machining for vertical locking points

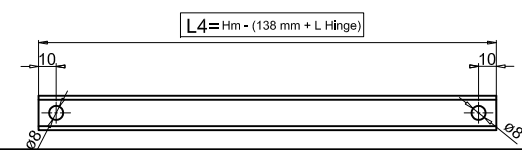

L5 - Rod machining for vertical locking points

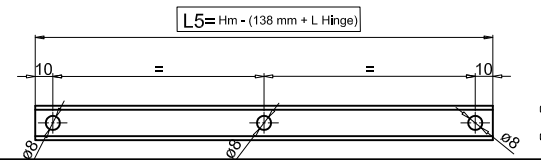

L6 - Rod machining for vertical locking points

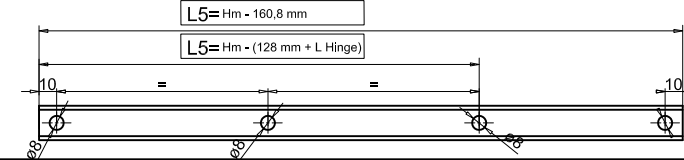

① stay- hinge  
 Z 997435  
 Z 997436  
 Z 997437  
 Z 997438  
 Z 997439  
 Z 997440  
 Z 997441  
 Z 997442  
 Z 997443

② position regulator  
 Z 997444

③ Kit for basic locking  
 Z 997455

④ extra locking pin  
 Z 918507

⑤ position regulator  
 K 910137

⑥ grip handle  
 Z 997453/ Z997456

⑦ driver for grip handle  
 Z 997452

⑧ Transmission corner  
 Z 918508

⑨ additional closing point  
 Z 997424

⑩ friction limiter arm  
 Z 997446  
 Z 997447  
 Z 997448

⑪ telescopic limiter arm table  
 Z 997449  
 Z 997450  
 Z 997451

L1 - Machining for cremone rod and horizontal locking points

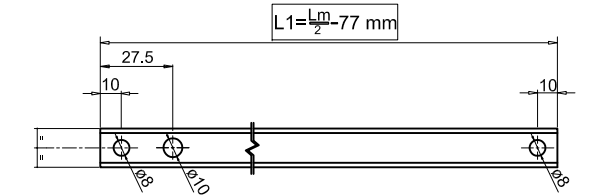

L2 - Machining for cremone rod and horizontal locking points

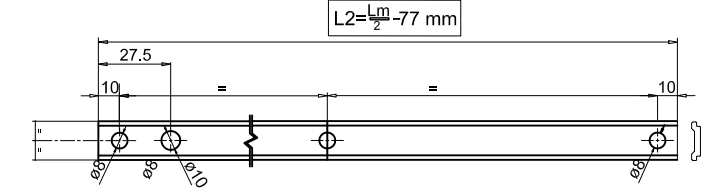

L3 - Machining for cremone rod and horizontal locking points

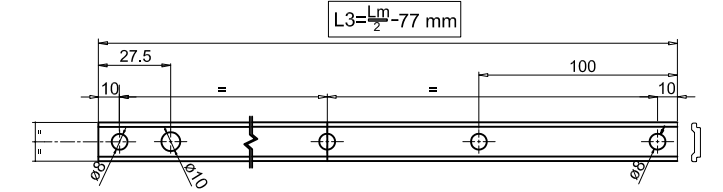

L7 - Machining for cremone rod and horizontal locking points

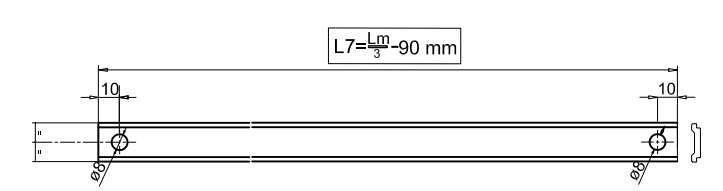

LOCKING POINT FOR DIMENSION L < 800 mm.

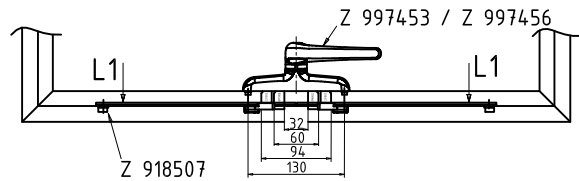

$$L1 = \frac{Lm}{2} - 77 \text{ mm}$$

Locking point for dimension L > 800 mm.

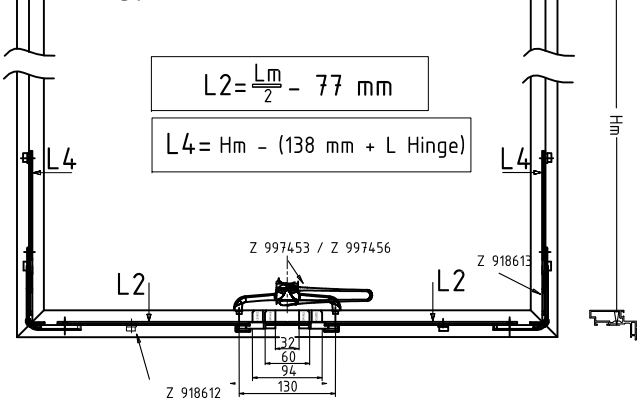

$$L2 = \frac{Lm}{2} - 77 \text{ mm}$$

$$L4 = Hm - (138 \text{ mm} + L \text{ Hinge})$$

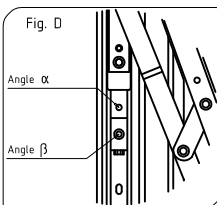
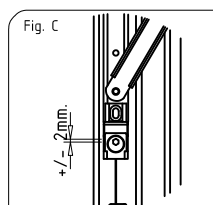
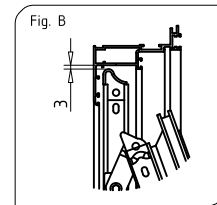
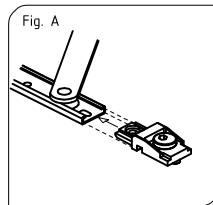

Make on the mullion and sash the positioning holes F1 and F3 hole diameter 7 mm for the height regulator;  
Apply at the bottom of the Stay Hinge the height regulator Fig. A;  
Apply the Stay Hinge at the mullion 3mm from the upper Cross ( Fig. B) and apply the first mounting screws in slotted holes F1 and the hole F3 of the height regulator;  
Apply the sash and apply the first screws in holes F1 of the sash;  
Make the Stay Hinge adjustment through the height regulator Fig. C;  
Block the opening angle through the latch plate positioning Fig. D and add the single limiter if necessary  
Make on the mullion and sash the positioning holes F2;  
Complete installation with screws ( not included), lock all screws with Loctite suitable. Use screws suitable to the type and dimensions of the windows.

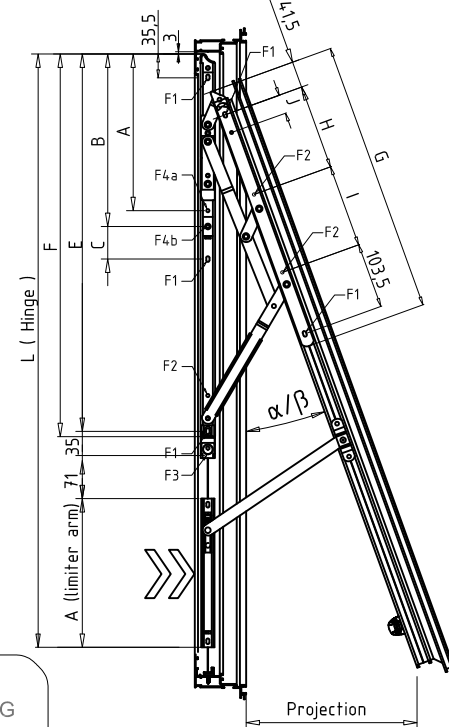

**WARNING**

Check the total dimensions for a correct combination of stay hinge and limiter

### ADJUSTMENTS

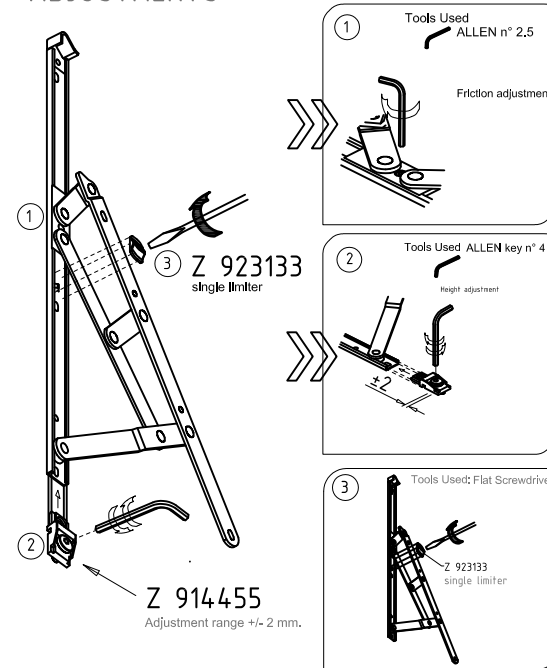

- The positioning indications are referred to the center line of the slots and holes;
- Check that all parts of the stay hinge are clean and lubricated;
- Use all holes and slots for fastening
- Periodically repeat cleaning, lubrication and check the tightness of the screws;

### Stay hinge load capacity with and without limiters

Art	α/β	Application Range					
		15°	20°	25°	30°	35°	40°
Z 997435		55Kg	50Kg	47Kg	44Kg	40Kg	35Kg
Limiter		Z 997446	Z 997446	Z 997446	Z 997446	Z 997446	Z 997446
restrictor		Z 997448	Z 997448	Z 923133	Z 923133	β	α

Art	α/β	Application Range						
		10°	15°	20°	25°	30°	35°	40°
Z 997436		80Kg	79Kg	77Kg	72Kg	65Kg	56Kg	40Kg
Limiter		Z 997446	Z 997446	Z 997446	Z 997446	Z 997446	Z 997446	Z 997446
restrictor		Z 997448	Z 997448	Z 923133	Z 923133	β	Z 923133	α

Art	α/β	Application Range						
		10°	15°	20°	25°	30°	35°	40°
Z 997437		95Kg	92Kg	87Kg	80Kg	72Kg	65Kg	50Kg
Limiter		Z 997446	Z 997446	Z 997446	Z 997446	Z 997446	Z 997446	Z 997446
restrictor		Z 997448	Z 997448	Z 923133	Z 923133	β	Z 923133	α

Art	α/β	Application Range					
		8°	15°	20°	25°	30°	35°
Z 997438		115Kg	111Kg	105Kg	95Kg	82Kg	65Kg
Limiter		Z 997446	Z 997446	Z 997446	Z 997446	Z 997446	Z 997446
restrictor		Z 997448	Z 997448	Z 923133	β	Z 923133	α

Art	α/β	Application Range						
		7°	10°	15°	20°	25°	30°	35°
Z 997439		130Kg	128Kg	123Kg	116Kg	105Kg	91Kg	75Kg
Limiter		Z 997446	Z 997446	Z 997446	Z 997446	Z 997446	Z 997446	Z 997446
restrictor		Z 997448	Z 997448	Z 923133	Z 923133	β	Z 923133	α

Art	α/β	Application Range					
		6°	10°	15°	20°	25°	30°
Z 997440		140Kg	135Kg	128Kg	120Kg	111Kg	100Kg
Limiter		Z 997446	Z 997446	Z 997446	Z 997446	Z 997446	Z 997446
restrictor		Z 997448	Z 997448	Z 923133	β	Z 923133	α

Art	α/β	Application Range					
		5°	10°	15°	20°	25°	30°
Z 997441		145Kg	139Kg	132Kg	125Kg	118Kg	110Kg
Limiter		Z 997446	Z 997446	Z 997446	Z 997446	Z 997446	Z 997446
restrictor		Z 997448	Z 997448	Z 923133	β	Z 923133	α

Art	α/β	Application Range					
		5°	10°	15°	20°	25°	
Z 997442		150Kg	145Kg	138Kg	130Kg	120Kg	
Limiter		Z 997446	Z 997446	Z 997446	Z 997446	Z 997446	
restrictor		Z 997448	Z 997448	Z 923133	β	α	

Art	α/β	Application Range					
		3°	8°	10°	15°	20°	
Z 997443		165Kg	155Kg	148Kg	143Kg	140Kg	
Limiter		Z 997446	Z 997446	Z 997446	Z 997446	Z 997446	
restrictor		Z 997448	Z 997448	β	Z 923133	α	

### Application Range

Art	L inch	L mm	Opening α/β	Load Kg	Min/Max H mm	Max L mm
Z 997435	10	260.5	15 - 40	55 - 35	450/600	1200
Z 997436	12	311	10 - 40	80 - 45	600/800	1200
Z 997437	14	349.5	10 - 40	95 - 50	800/1000	1200
Z 997438	16	410.5	8 - 35	115 - 65	1000/1200	1200
Z 997439	18	455.5	7 - 35	130 - 75	1200/1400	1500
Z 997440	20	509.5	6 - 30	140 - 100	1400/1600	1600
Z 997441	22	555.5	5 - 30	145 - 110	1600/1800	1800
Z 997442	24	599.5	5 - 25	150 - 120	1600/1800	1800
Z 997443	28	713	3 - 20	165 - 140	1800/2000	2000

### Drilling Indication

Art	L inch	β	α	A	B	C	D	E	F	G	H	I	J
Z 997435	10	45	35	160	183.5	n.p.	211.5	254	263	205	40	n.p.	n.p.
Z 997436	12	40	30	172.5	214	n.p.	249.5	305	313	252.5	40	40	n.p.
Z 997437	14	40	30	180.5	227	n.p.	288.5	344	351	275	40	70	n.p.
Z 997438	16	35	25	173	225	46	348.5	404.5	412.5	313.5	40	108.5	n.p.
Z 997439	18	35	25	179.5	239.5	46	393.5	450	458.5	340	70	105	n.p.
Z 997440	20	30	20	174	228	46	448	503.5	512	376	89.5	121.5	n.p.
Z 997441	22	30	20	182	241	46	494	547.5	555.5	403.5	103	135.5	n.p.
Z 997442	24	25	20	246	270.5	46	538	594.5	602	430	135	130	30
Z 997443	28	20	10	230	261.5	46	637.5	707	715	452	135	152	30

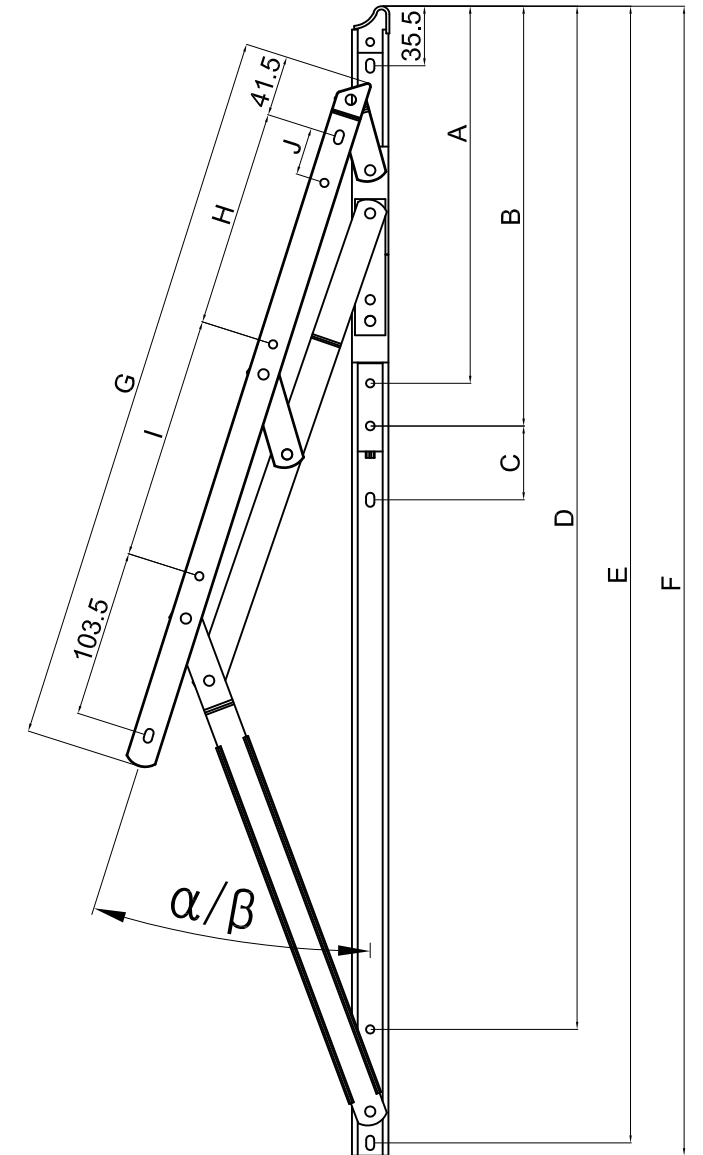

For Aluminium minimum thickness 2mm best with rive nut  
For Aluminium thickness 4mm best with self-tapping screws Ø 4,8 + all screws secured with Loctite

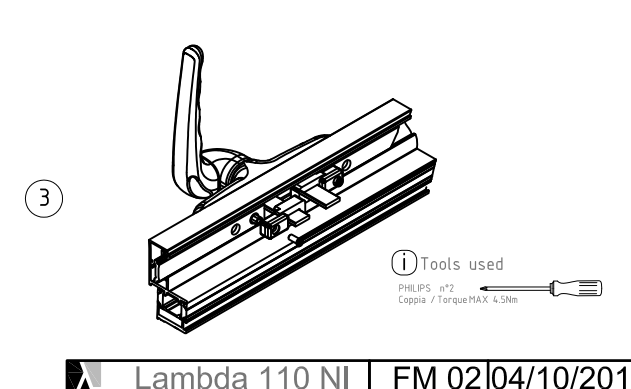
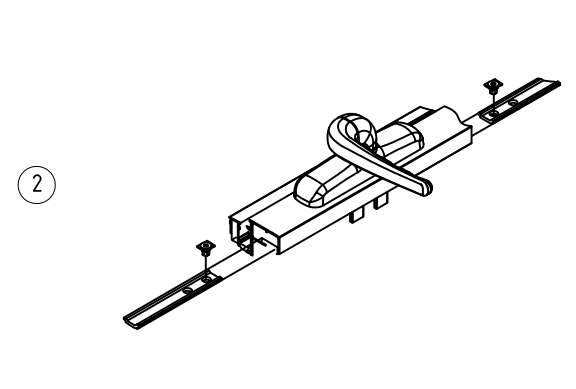
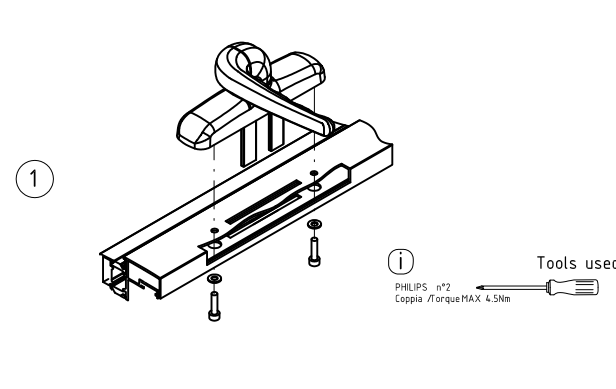
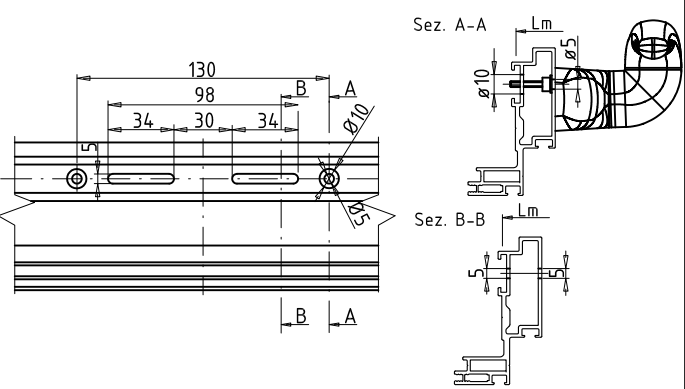

Lambda 110 NI  
 opening Limiter

LIMITER Z 997446 - Z 997447 - Z 997448

DESCRIPTION	ART.	A (INCH)	A (MM)	B (MM)	C (MM)
Friction limited arm	Z 997446	6"	150,5	131	85,4
	Z 997447	8"	201	184	152
	Z 997448	10"	154	236	180
Additional release key	Z 918611				

AISI 304 stainless steel arms, Delrin opening limit block, die-cast aluminum release key.

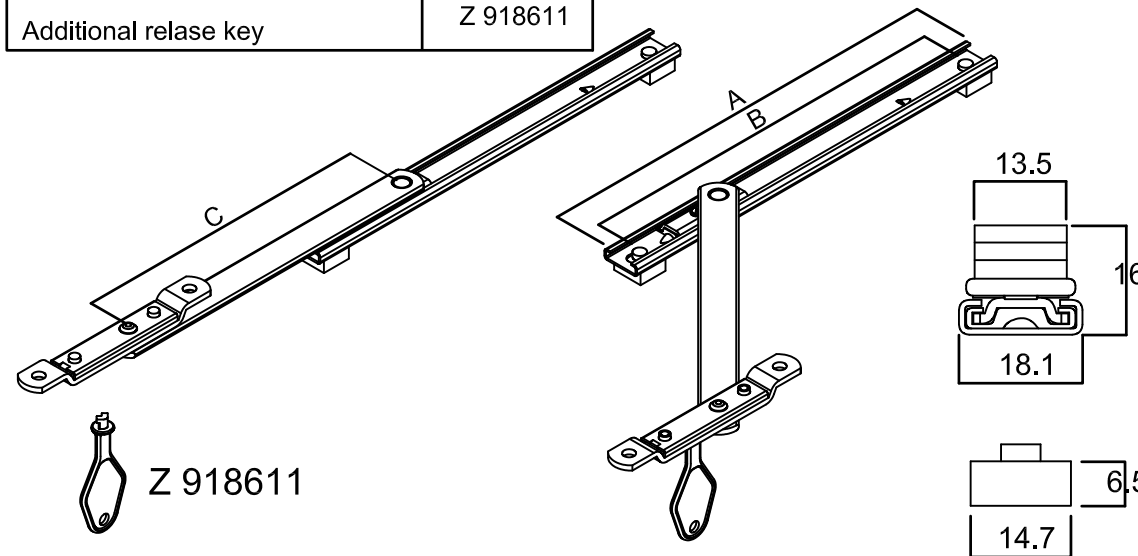

SASH

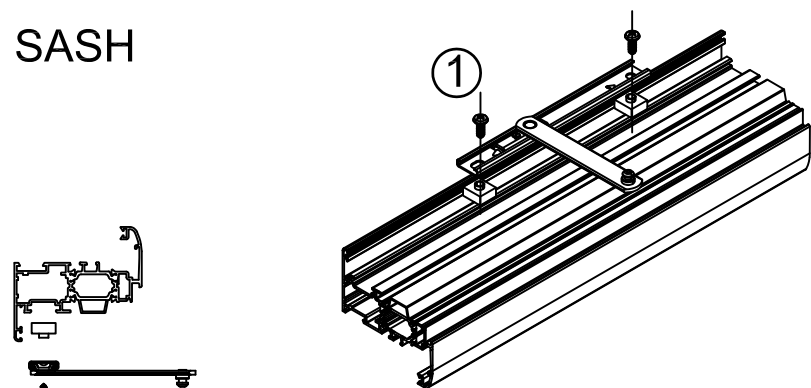

FRAME

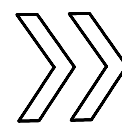
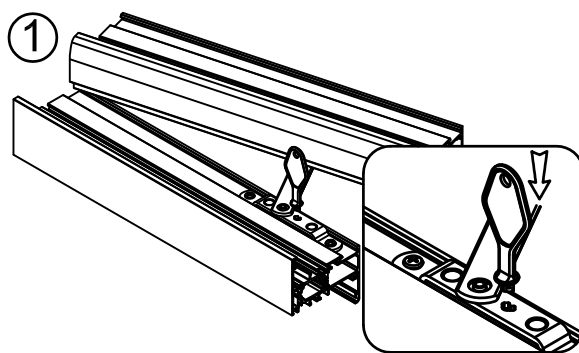
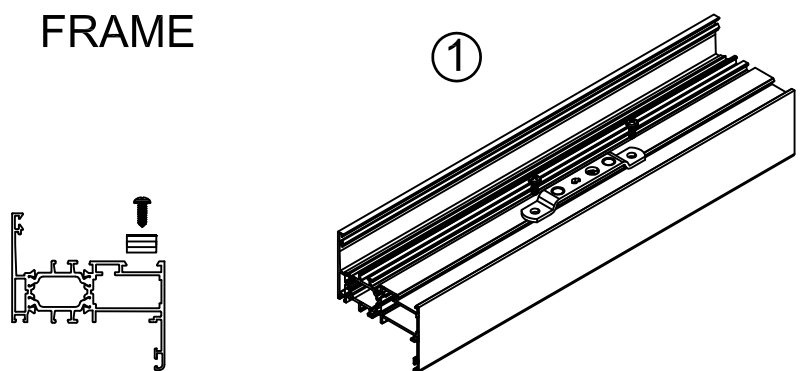

2

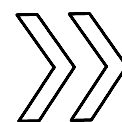
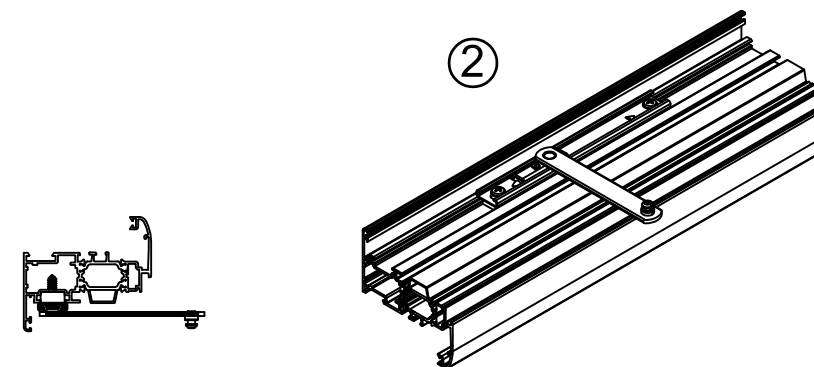

2

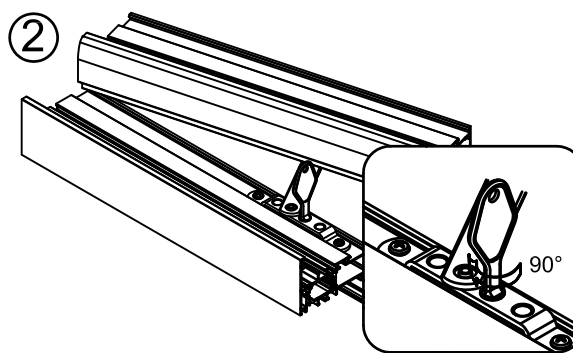
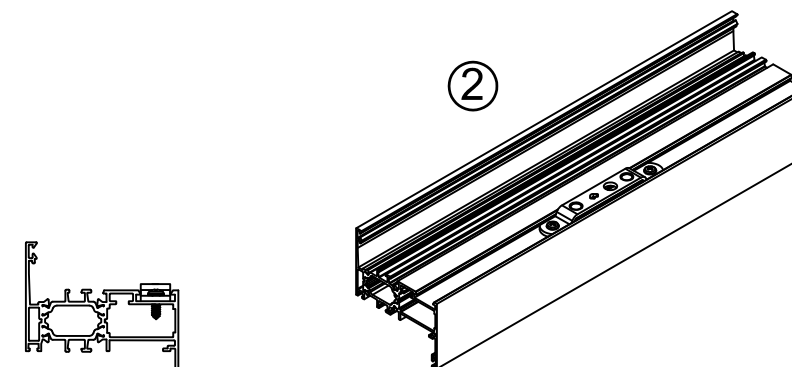

3

