

VOLATO SL 40 ISO
SL 40 ISO SG

SCHIEBE-SYSTEM
SLIDING-SYSTEM



ALUMINIUM SYSTEMS 
HUECK
GERMAN ENGINEERING SINCE 1814

VOLATO SL 40 ISO SL 40 ISO SG

SLIDING SYSTEMS
WINDOW & DOOR

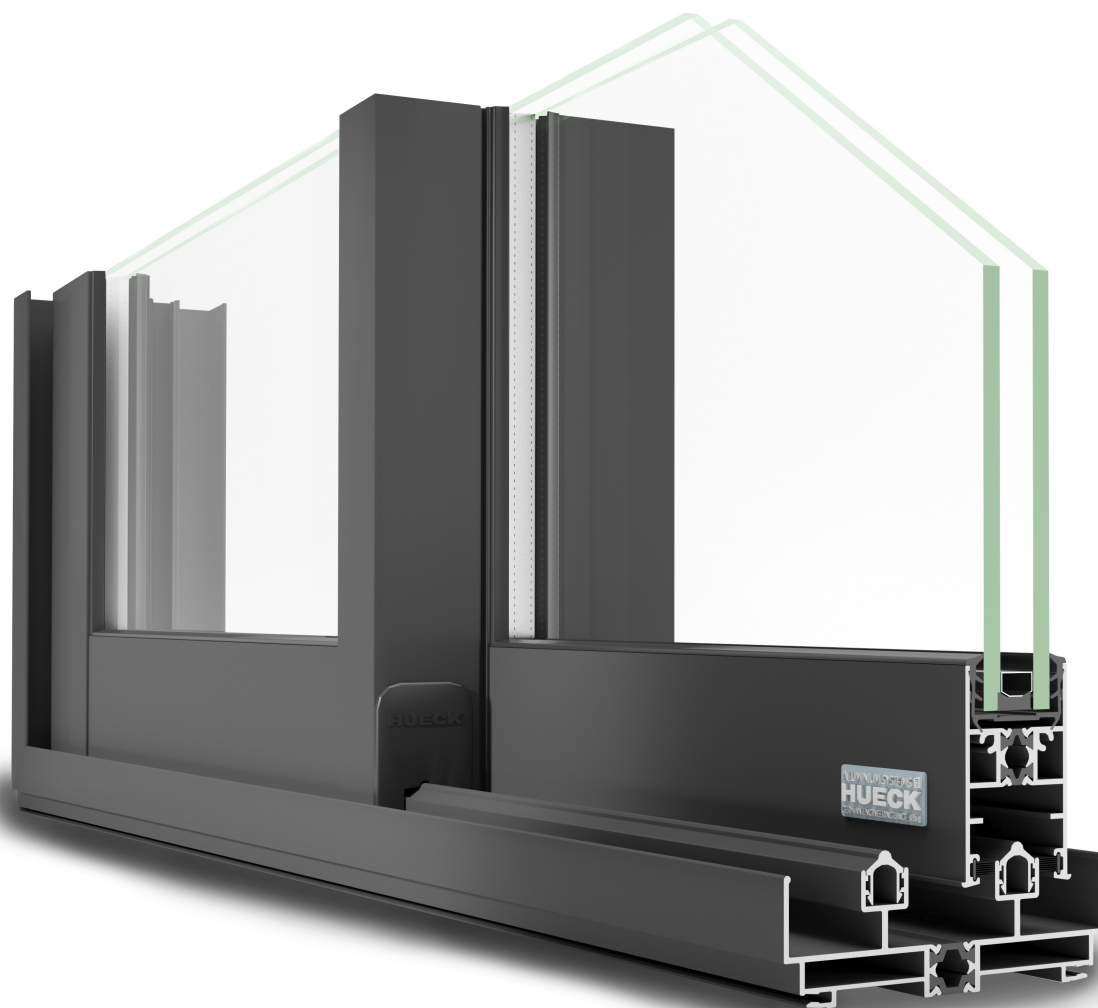

Volato - Sliding construction	
Contents - Volato SL 40 ISO & Volato SL 40 ISO SG	Page
Contents	6
Series Information Product Pass Test Report	A1 - A6
Profile overview Static profile value	B1 - B4
Profiles Connections	C1 - C15
Glazing Structural analysis Thermal analysis	D1 - D6
Sections / Details Construction Details	E1 - E43
System-dependent accessories	F1 - F9
Processing	G1 - G45

Aluminium construction made of profiles for slight sliding windows/doors

Series information*

Design features	<ul style="list-style-type: none"> • Variety of design possibilities for sliding windows and sliding doors • Sash weight max. 200kg • Sash height max. 3700mm by max. sash width 1800mm • Reinforced labyrinth-profiles • Complementary Fittings, Accessories, supplementary profiles, tools and auxiliary accessories • Flyscreen possible
Surfaces	<ul style="list-style-type: none"> • Anodisation in accordance with DIN 17611 • Plastic coating (wet paint, powder coating lacquer) in accordance with DIN 50939
Connecting technology	<ul style="list-style-type: none"> • Different or same frame profile horizontal and vertical • Simple processing because of linear joints in sash frames • Drilled profile joints • Corner cleats for crimping and pinning
Elevation width	<ul style="list-style-type: none"> • Fixed frame: lateral 44,5 mm around, at the top/lower 45 mm • sash frame: lateral 53,4 mm, at the top/lower 60 mm • Labyrinth: 34 mm • Sash joint scheme B and C: 110 mm • Reduced profile width for SG version
Profile depth	<ul style="list-style-type: none"> • Fixed frame: 103 mm, 108 mm, 113 mm, 159mm • Sash frame: 40 mm
Glazing	<ul style="list-style-type: none"> • Glass thickness between 24 mm and 30 mm
Gaskets	<ul style="list-style-type: none"> • Plastic sliding gasket • Pile with middle bridge in the labyrinth-area • Glazing gaskets: U-shaped gasket profiles, optionally can be drawn in continuously or drawn in mitre joint
Tandem roller	<ul style="list-style-type: none"> • Adjustable in height or fixed • Combination of single-roll and tandem roll for a sash weight of max 200kg
Possible	<ul style="list-style-type: none"> • Configuration as Monorail, Double Track, Triple Track, Corner • SG optic with reduced visible sash of 19mm

* All standards referred to herein, were valid at time of printing.

Valid test reports as well as technical information can be found in the download area of the site www.hueck.ae

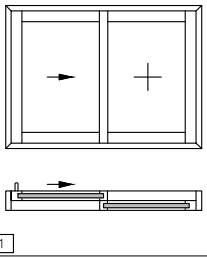
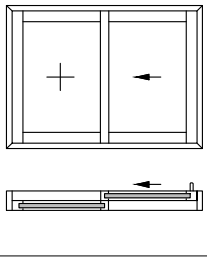
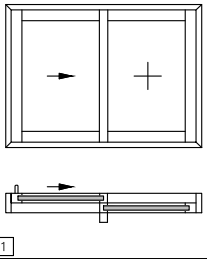
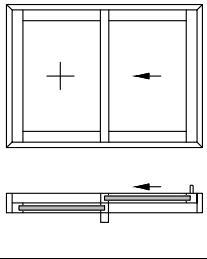
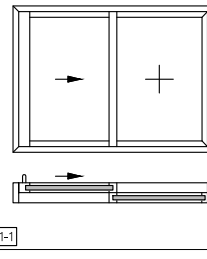
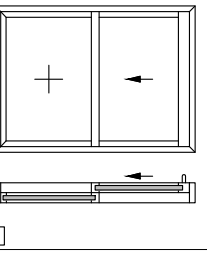
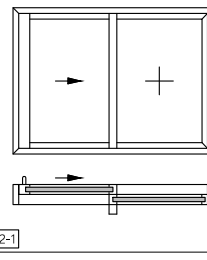
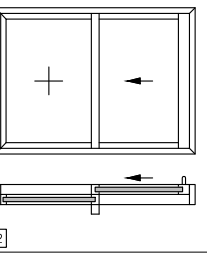
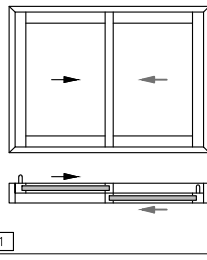
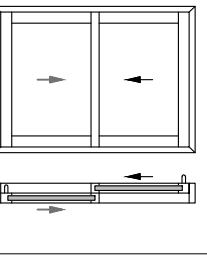
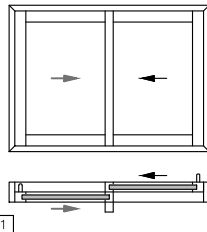
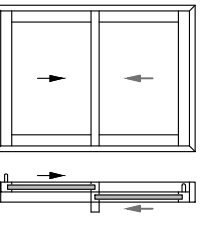
OVERVIEW OF SCHEMES (VIEW FROM THE OUTSIDE)			
SCHEME	LABYRINTH	LABYRINTH (HANDED)	DESCRIPTION
A1			<p>SL 40ISO_A1-1 (Window labyrinth) Double-tracked system with 2 fields Sliding sash left, fixed sash right Primary sash sliding to the left</p> <p>SL 40ISO_A1-2 (Window labyrinth) Double-tracked system 2 fields Sliding sash right, fixed sash left Primary sash sliding to the right</p>
			<p>SL 40ISO_A2-1 (Door labyrinth) Double-tracked system with 2 fields Sliding sash left, fixed sash right Primary sash sliding to the left</p> <p>SL 40ISO_A2-2 (Door labyrinth) Double-tracked system 2 fields Sliding sash right, fixed sash left Primary sash sliding to the right</p>
MA1			<p>SL 40ISO_MA1-1 (Window labyrinth) Monorail with 2 fields Sliding sash left, fixed field right Primary sash sliding to left</p> <p>SL 40ISO_MA1-2 (Window labyrinth) Monorail with 2 fields Sliding sash right, fixed field left Primary sash sliding to right</p>
			<p>SL 40ISO_MA2-1 (Door labyrinth) Monorail with 2 fields Sliding sash left, fixed field right Primary sash sliding to left</p> <p>SL 40ISO_MA2-2 (Door labyrinth) Monorail with 2 fields Sliding sash right, fixed field left Primary sash sliding to right</p>
D1			<p>SL 40ISO_D1-1 (Window labyrinth) Double-tracked system with 2 fields Sliding sash left, sliding sash right Primary sash sliding to left</p> <p>SL 40ISO_D1-2 (Window labyrinth) Double-tracked system 2 fields Sliding sash right, sliding sash left Primary sash sliding to right</p>
			<p>SL 40ISO_D2-1 (Door labyrinth) Double-tracked system with 2 fields Sliding sash left, sliding sash right Primary sash sliding to left</p> <p>SL 40ISO_D2-2 (Door labyrinth) Double-tracked system 2 fields Sliding sash right, sliding sash left Primary sash sliding to right</p>

OVERVIEW OF SCHEMES (VIEW FROM THE OUTSIDE)

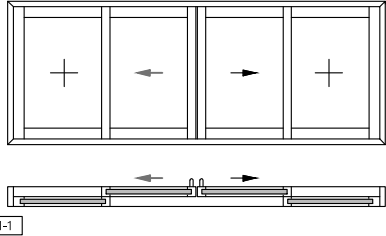
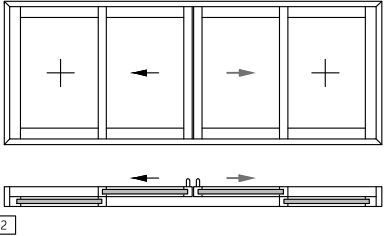
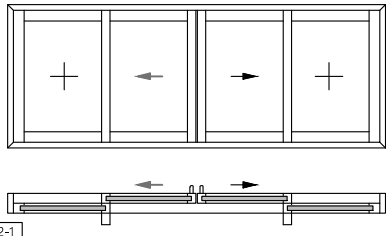
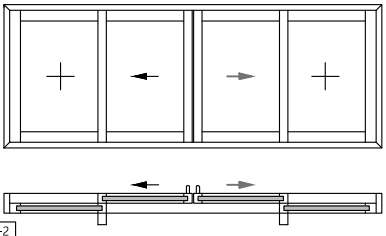
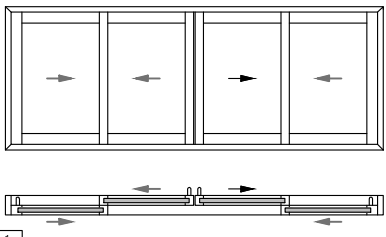
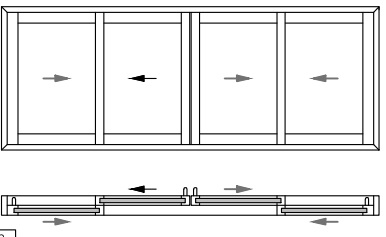
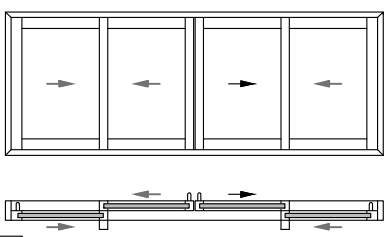
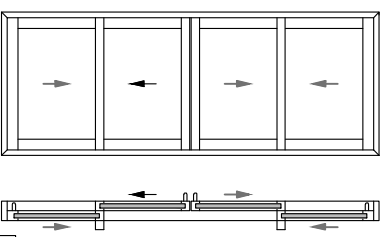
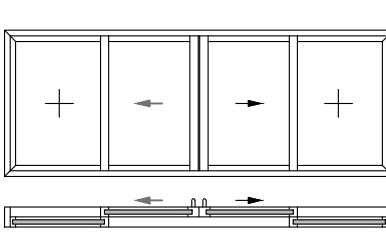
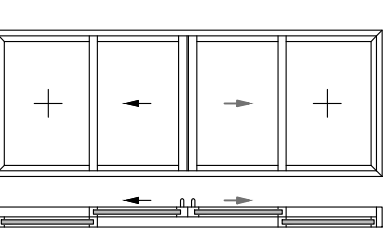
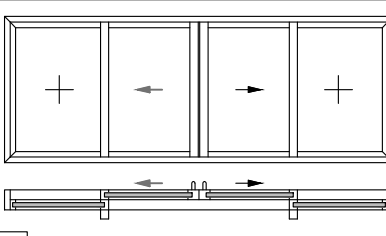
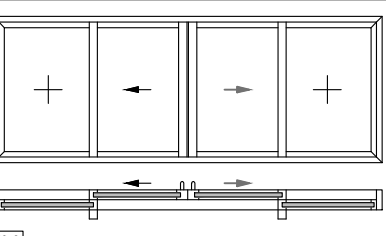
SCHEME	LABYRINTH	LABYRINTH (HANDED)	DESCRIPTION
C1			<p>SL 40ISO_C1-1 (Window labyrinth) Double-tracked system with 4 fields 2 Sliding sashes in the middle 1 fixed sash left and right each Primary sash sliding to the left</p> <p>SL 40ISO_C1-2 (Window labyrinth) Double-tracked system with 4 fields 2 Sliding sashes in the middle 1 fixed sash left and right each Primary sash sliding to the right</p>
C2			<p>SL 40ISO_C2-1 (Door labyrinth) Double-tracked system with 4 fields 2 Sliding sashes in the middle 1 fixed sash left and right each Primary sash sliding to the left</p> <p>SL 40ISO_C2-2 (Door labyrinth) Double-tracked system with 4 fields 2 Sliding sashes in the middle 1 fixed sash left and right each Primary sash sliding to the right</p>
F1			<p>SL 40ISO_F1-1 (Window labyrinth) Double-tracked system with 4 fields 4 sliding sashes Primary sash in the middle sliding to the left</p> <p>SL 40ISO_F1-2 (Window labyrinth) Double-tracked system with 4 fields 4 sliding sashes Primary sash in the middle sliding to the right</p>
F2			<p>SL 40ISO_F2-1 (Door labyrinth) Double-tracked system with 4 fields 4 sliding sashes Primary sash in the middle sliding to the left</p> <p>SL 40ISO_F2-2 (Door labyrinth) Double-tracked system with 4 fields 4 sliding sashes Primary sash in the middle sliding to the right</p>
MC1			<p>SL 40ISO_MC1-1 (Window labyrinth) Monorail with 4 fields 2 Sliding sashes in the middle 1 fixed field left and right each Primary sash sliding to the left</p> <p>SL 40ISO_MC1-2 (Window labyrinth) Monorail with 4 fields 2 Sliding sashes in the middle 1 fixed field left and right each Primary sash sliding to the right</p>
MC2			<p>SL 40ISO_MC2-1 (Door labyrinth) Monorail with 4 fields 2 Sliding sashes in the middle 1 fixed field left and right each Primary sash sliding to the left</p> <p>SL 40ISO_MC2-2 (Door labyrinth) Monorail with 4 fields 2 Sliding sashes in the middle 1 fixed field left and right each Primary sash sliding to the right</p>

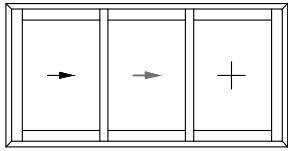
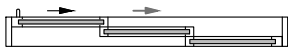
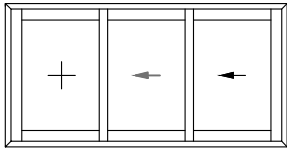
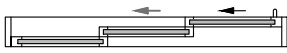
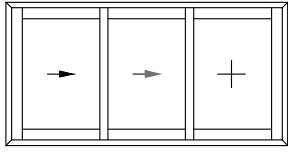
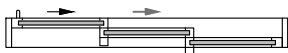
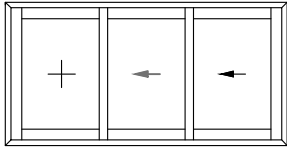
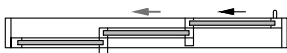
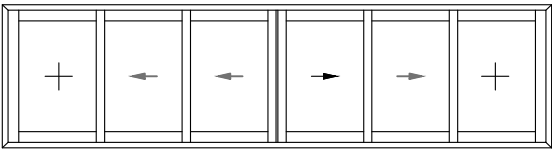
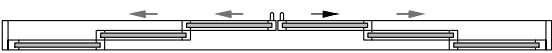
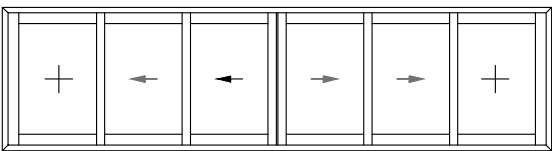
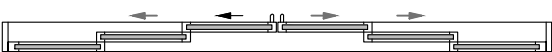
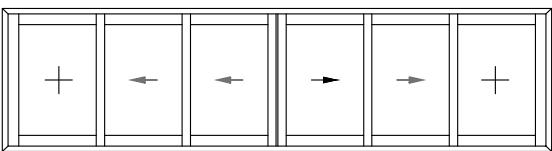
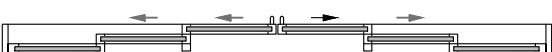
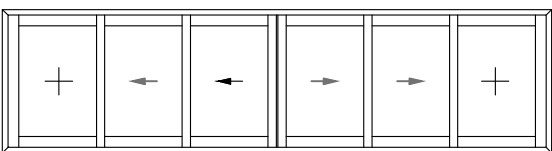
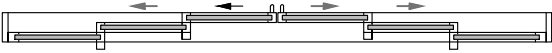

OVERVIEW OF SCHEMES (VIEW FROM THE OUTSIDE)			
SCHEME	LABYRINTH	LABYRINTH (HANDED)	DESCRIPTION
E1	  <small>E1-1</small>	  <small>E1-2</small>	<p>SL 40ISO_E1-1 (Window labyrinth) Triple-tracked system with 3 fields 2 sliding sashes, 1 fixed sash Primary sash on the left side seen from the inside sliding to the left</p> <p>SL 40ISO_E1-2 (Window labyrinth) Triple-tracked system with 3 fields 2 sliding sashes, 1 fixed sash Primary sash on the right side seen from the inside sliding to the right</p>
	E2	  <small>E2-1</small>	  <small>E2-2</small>
L1-1		  <small>L1-1</small>	
	L1-2	  <small>L1-2</small>	
L2-1		  <small>L2-1</small>	
	L2-2	  <small>L2-2</small>	

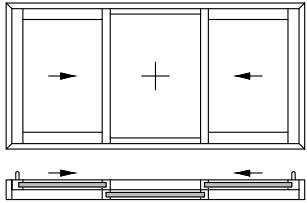
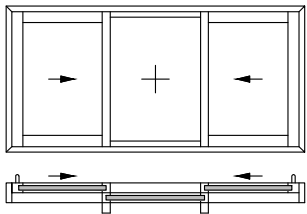
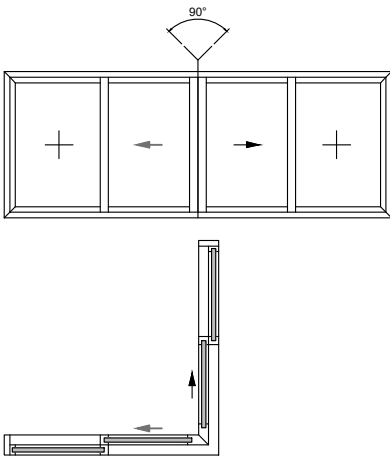
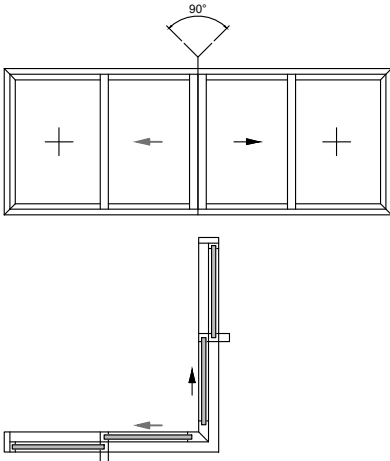
OVERVIEW OF SCHEMES (VIEW FROM THE OUTSIDE)		
SCHEME	LABYRINTH	DESCRIPTION
MK1	 <p>Diagram showing a three-field window with arrows indicating sliding directions and a cross-section below.</p>	<p>SL 40ISO_MK1 (Window labyrinth) Monorail with 3 fields Sliding sashes left and right Fixed field in the middle Primary sashes sliding to the left and right</p>
MK2	 <p>Diagram showing a three-field door with arrows indicating sliding directions and a cross-section below.</p>	<p>SL 40ISO_MK2 (Door labyrinth) Monorail with 3 fields Sliding sashes left and right Fixed field in the middle Primary sashes sliding to the left and right</p>
P1	 <p>Diagram showing a four-field corner window with arrows indicating sliding directions and a cross-section below.</p>	<p>SL 40ISO_P1 (Corner Window) Monorail with 4 fields 2 Sliding sashes in the middle 1 fixed field left and right each Primary sash sliding to the left</p>
P2	 <p>Diagram showing a four-field corner door with arrows indicating sliding directions and a cross-section below.</p>	<p>SL 40ISO_P2 (Corner Door) Monorail with 4 fields 2 Sliding sashes in the middle 1 fixed field left and right each Primary sash sliding to the left</p>

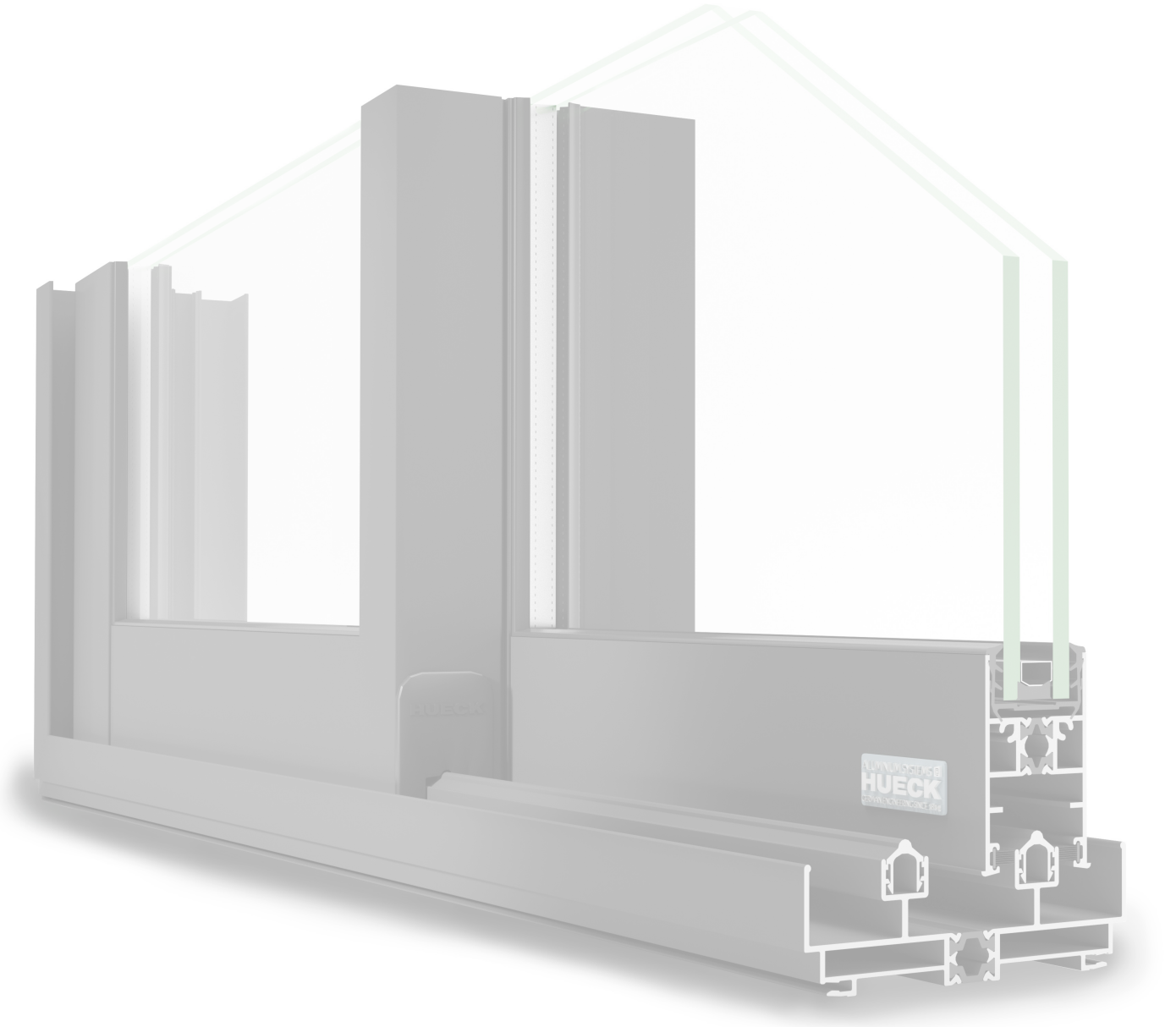

OVERVIEW OF SCHEMES (VIEW FROM THE OUTSIDE)		
SCHEME	LABYRINTH	DESCRIPTION
Q1	<p>The drawing shows a window with four panes. The two central panes have arrows pointing left and right, indicating they are sliding. The two outer panes have a cross symbol, indicating they are fixed. A 90-degree corner view is shown above the window. Below it is a detailed cross-section of the window frame and sashes, with arrows indicating the sliding direction of the sashes.</p>	<p>SL 40ISO_Q1 (Corner Window) Double-tracked system with 4 fields 2 Sliding sashes in the middle 1 fixed sash left and right each Primary sash sliding to the left</p>
Q2	<p>The drawing shows a window with four panes. The two central panes have arrows pointing left and right, indicating they are sliding. The two outer panes have a cross symbol, indicating they are fixed. A 90-degree corner view is shown above the window. Below it is a detailed cross-section of the window frame and sashes, with arrows indicating the sliding direction of the sashes.</p>	<p>SL 40ISO_Q2 (Corner Door) Double-tracked system with 4 fields 2 Sliding sashes in the middle 1 fixed sash left and right each Primary sash sliding to the left</p>
S1	<p>The drawing shows a window with six panes. The two central panes have arrows pointing left and right, indicating they are sliding. The two outer panes have a cross symbol, indicating they are fixed. A 90-degree corner view is shown above the window. Below it is a detailed cross-section of the window frame and sashes, with arrows indicating the sliding direction of the sashes.</p>	<p>SL 40ISO_S1 (Corner Door) Triple-tracked system with 6 fields 4 sliding sashes, 2 fixed sash Primary sash in the middle sliding to the left</p>

HUECK





12/2022

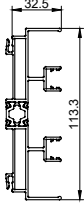
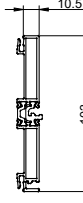
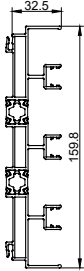
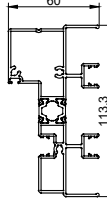
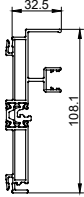
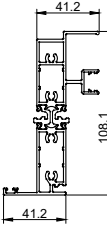
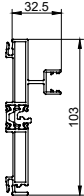
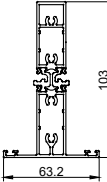





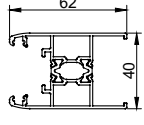
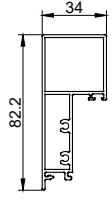
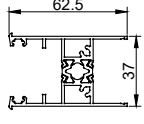
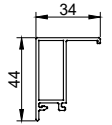
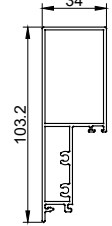
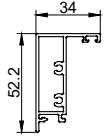
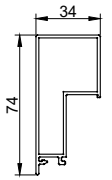
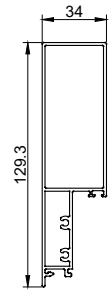
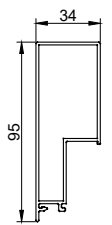
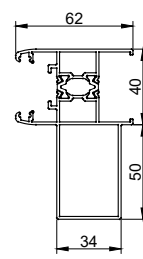

Profile overview and static profile values for Series SL 40 ISO & SL 40 ISO SG

	Profile number	Horizontal axis		Vertical axis		External perimeter complete	Page -		Profile number	Horizontal axis		Vertical axis		External perimeter complete	Page -
		J_x (cm ⁴)	W_x (cm ³)	J_y (cm ⁴)	W_y (cm ³)					J_x (cm ⁴)	W_x (cm ³)	J_y (cm ⁴)	W_y (cm ³)		
	B 061300	75.9	13.4	6.33	2.95	639	C1		B 061309	41.68	7.92	0.89	1.06	357.8	C3
	B 061301	203.7	25.5	8.74	4.05	891	C1		B 061302	96.45	16.22	19.85	6.21	681.5	C4
	B 061305	57	9.7	4.17	1.74	508	C2		B 061311	90.37	16.61	10.49	3.12	539.5	C4
	B 061312	45.87	8.44	3.35	1.34	454	C2		B 061313	79.58	13.74	7.37	2.33	430	C5

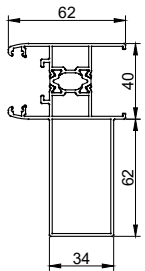
Profile overview and static profile values for Series SL 40 ISO & SL 40 ISO SG

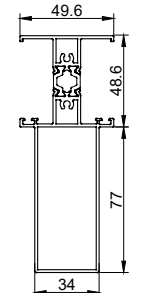

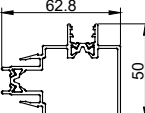
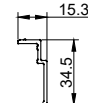
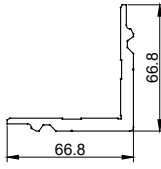

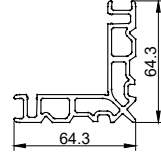
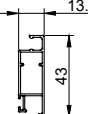
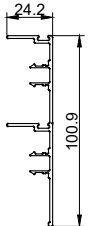
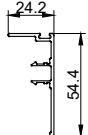





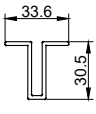

	Profile number	Horizontal axis		Vertical axis		External perimeter complete	Page -		Profile number	Horizontal axis		Vertical axis		External perimeter complete	Page -
		J_x (cm ⁴)	W_x (cm ³)	J_y (cm ⁴)	W_y (cm ³)					J_x (cm ⁴)	W_x (cm ³)	J_y (cm ⁴)	W_y (cm ³)		
	B 061303	9.44	4.72	9.96	3.07	434	C6		P 061153	25	5.69	5.26	2.5	267	C11
	B 061304	8.4	4.2	9.48	3.02	411.4	C6								
	P 061108	4.2	1.62	1.61	0.68	176.4	C10		P 061134	46.36	8.8	7.09	3.47	309	C11
	P 061109	7.5	2.5	2.05	0.89	207.3	C10								
	P 061152	17.3	4.22	4.77	2.32	236	C11		P 061128	87.39	13.39	9.32	4.7	361	C11
	P 061111	34.27	6.73	6.58	3.31	278	C11		B 061307	49.06	9.11	15.41	4.74	533	C7

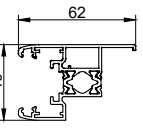
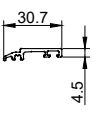
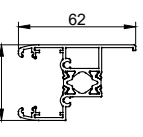
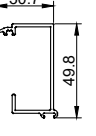
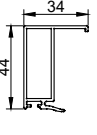
Profile overview and static profile values for Series SL 40 ISO & SL 40 ISO SG

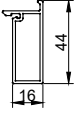

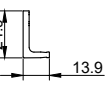

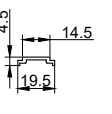



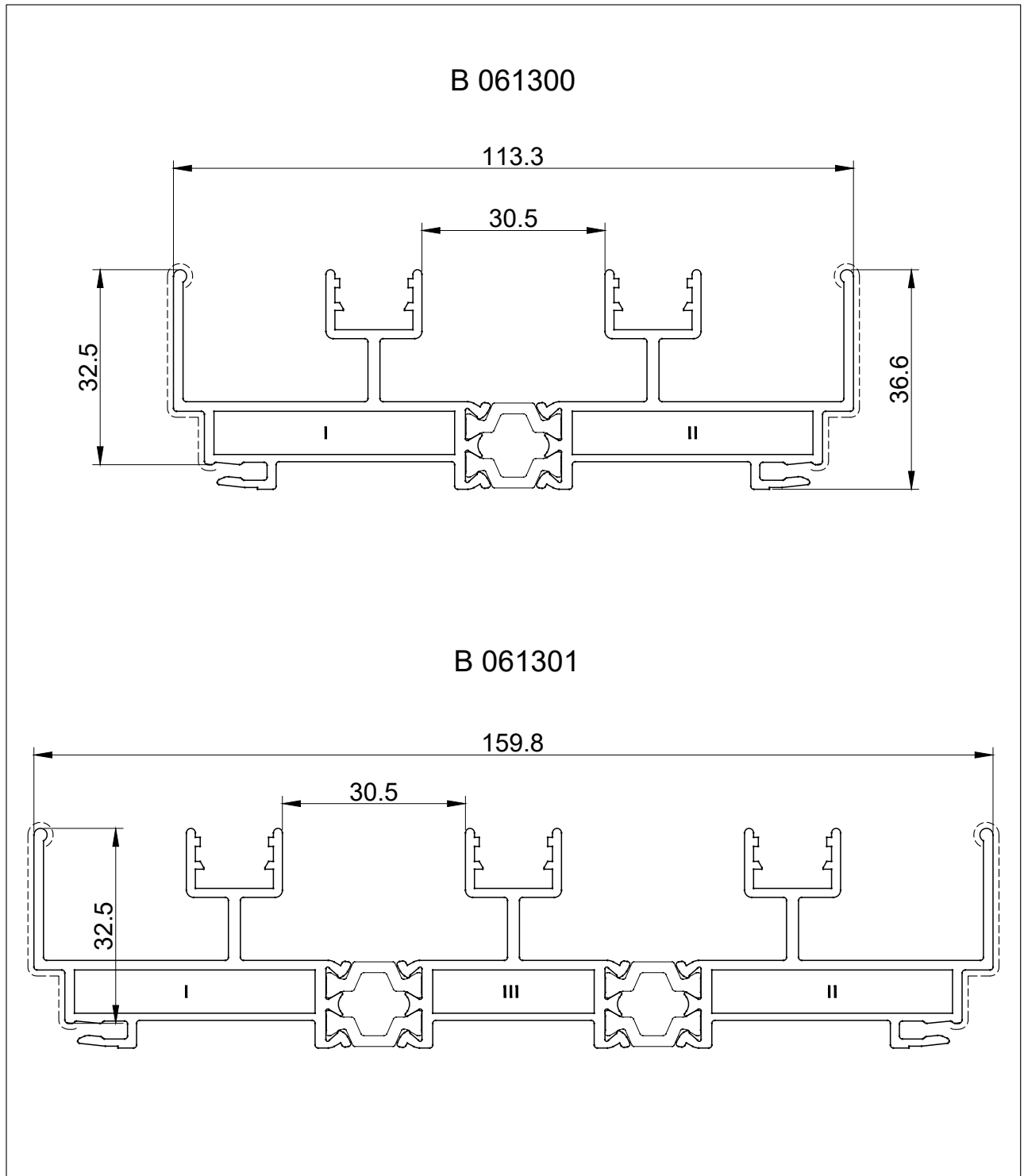



	Profile number	Horizontal axis		Vertical axis		External perimeter complete	Page		Profile number	Horizontal axis		Vertical axis		External perimeter complete	Page
		J_x (cm ⁴)	W_x (cm ³)	J_y (cm ⁴)	W_y (cm ³)					J_x (cm ⁴)	W_x (cm ³)	J_y (cm ⁴)	W_y (cm ³)		
	B 061308	67.44	10.93	16.5	5.02	557	C7		P 061115	-	-	-	-	-	C12
	B 061310	105.7	14.61	11.27	4.55	511.2	C8		P 061135	-	-	-	-	-	C12
	B 061306	8.78	3.25	14.62	4.33	519	C9		P 061138	-	-	-	-	-	C12
	P 499605	-	-	-	-	-	C13		P 061139	-	-	-	-	-	C12
	P 599343	-	-	-	-	-	C13		P 066055	-	-	-	-	-	C14
									P 061116	-	-	-	-	-	C12
									P 061143	-	-	-	-	-	C12

Profile overview and static profile values for Series SL 40 ISO & SL 40 ISO SG

Profile Overview

	Profile number	Horizontal axis		Vertical axis		External perimeter complete	Page		Profile number	Horizontal axis		Vertical axis		External perimeter complete	Page
		J_x (cm ⁴)	W_x (cm ³)	J_y (cm ⁴)	W_y (cm ³)					J_x (cm ⁴)	W_x (cm ³)	J_y (cm ⁴)	W_y (cm ³)		
	P 061107	-	-	-	-	-	C14		P 816603	-	-	-	-	-	C15
	P 061122	-	-	-	-	-	C15		B 061314	6.86	2.91	7.55	2.13	421.4	C6
	P 061123	-	-	-	-	-	C15		B 061315	6.69	2.81	7.38	2.12	392	C6
	P 061117	-	-	-	-	-	C14		P 061149	5.87	2.44	1.66	0.72	192	C10
	P 061136	-	-	-	-	-	C14		P 061150	3.61	1.64	0.84	0.64	140	C10
	P 816600	-	-	-	-	-	C14		P 061151	-	-	-	-	-	C14
	P 061112	-	-	-	-	-	C14		H 062007	-	-	-	-	-	C12
	P 061140	-	-	-	-	-	C14								
	P 499760	-	-	-	-	-	C14								



 crimpable  nailable  retro gluing after assembly	Internal profile chamber (I)			Middle profile chamber (III)			External profile chamber (II)		
									
B 061300	Z 061505	2x Z 911513	Z 911187	-	-	-	Z 061505	2x Z 911513	Z 911187
B 061301	Z 061505	2x Z 911513	Z 911187	Z 061507	2x Z 911513	Z 911187	Z 061505	2x Z 911513	Z 911187





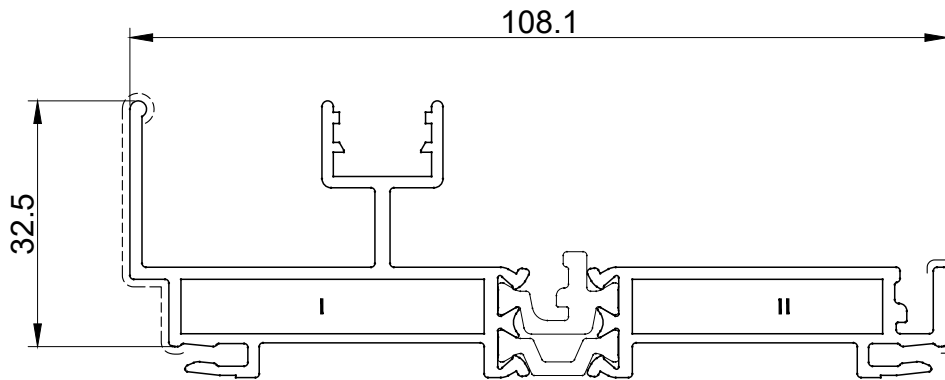

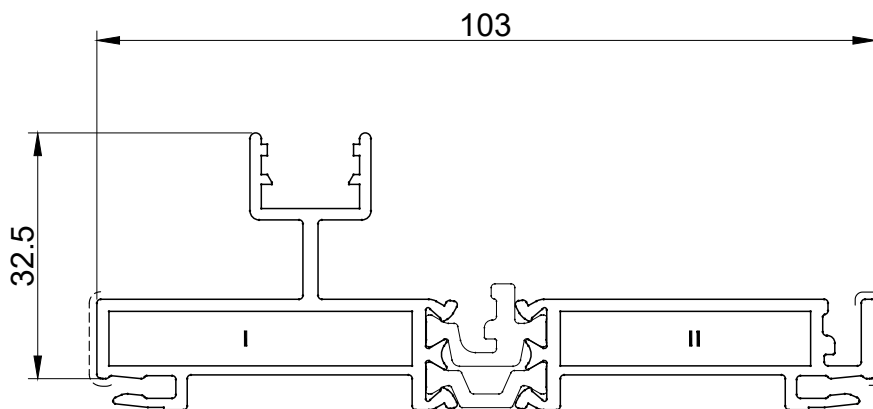

12/2022

B 061305











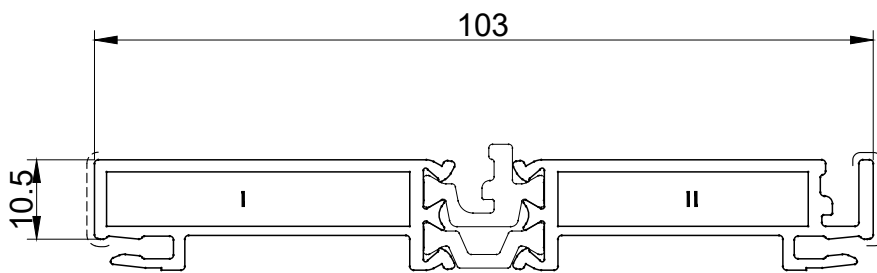

B 061312



<ul style="list-style-type: none">  crimpable  nailable  retro gluing after assembly 	Internal profile chamber (I)				External profile chamber (II)			
								
B 061305	Z 061505	2x Z 911513	Z 911187		Z 061506	2x Z 911513	Z 911187	
B 061312	Z 061505	2x Z 911513	Z 911187		Z 061506	2x Z 911513	Z 911187	

B 061309







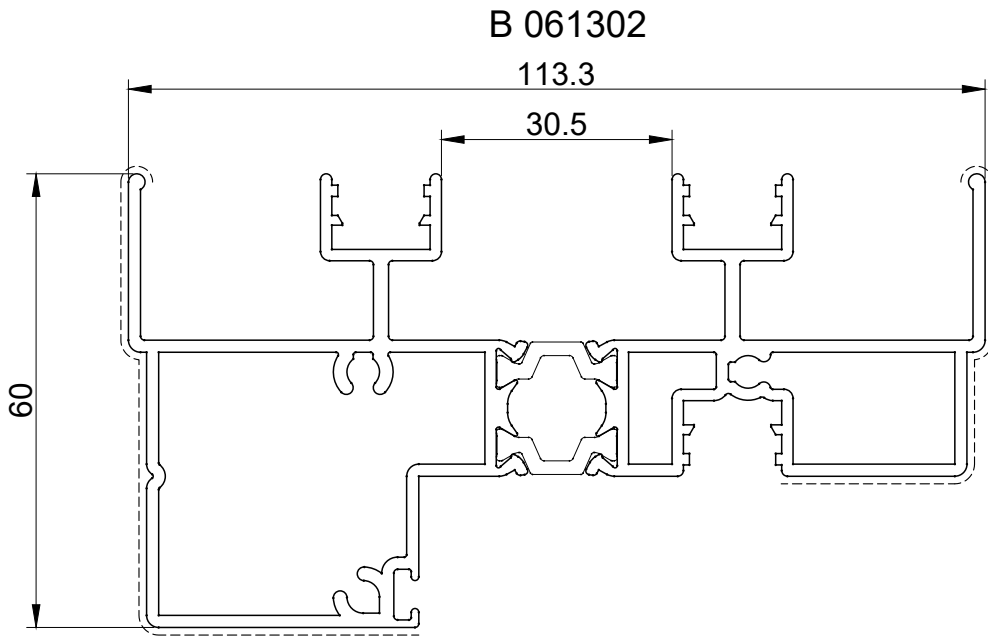

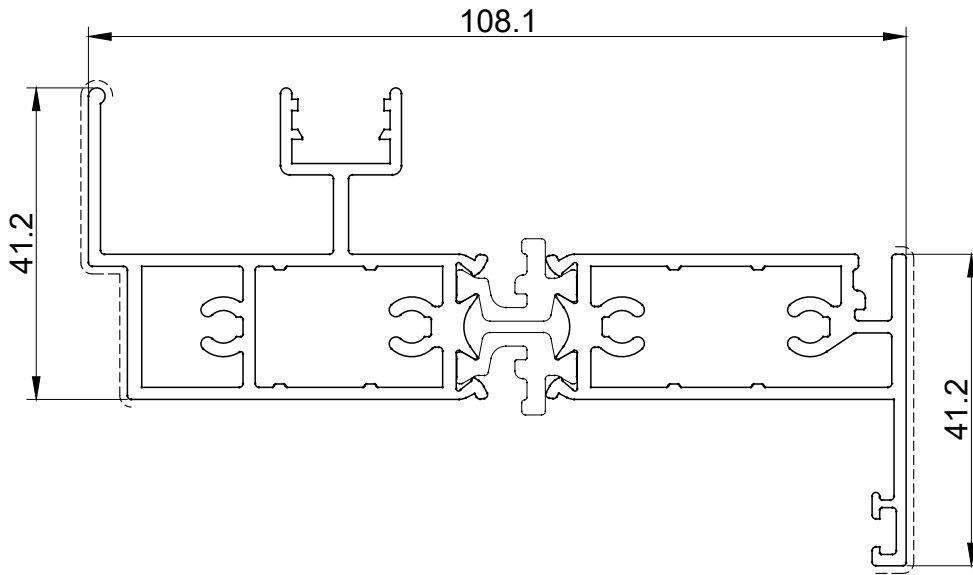

<ul style="list-style-type: none">  crimpable  nailable  retro gluing after assembly 	Internal profile chamber (I)				External profile chamber (II)			
	  	  						
B 061309	Z 061505	2x Z 911513	Z 911187		Z 061506	2x Z 911513	Z 911187	

12/2022







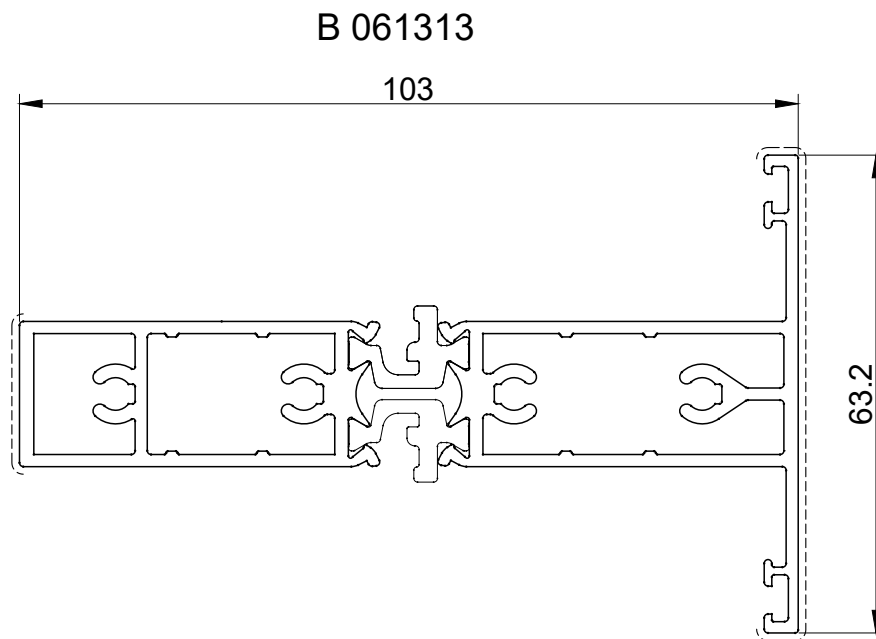

B 061311



<ul style="list-style-type: none">  crimpable  nailable  retro gluing after assembly 	chamber			
				
B 061302	-	-	3x Z 906602	-
B 061311	-	-	4x Z 906602	-



<ul style="list-style-type: none">  crimpable  nailable  retro gluing after assembly 	chamber			
				
B 061313	-	-	4x Z 906602	-

B 061303

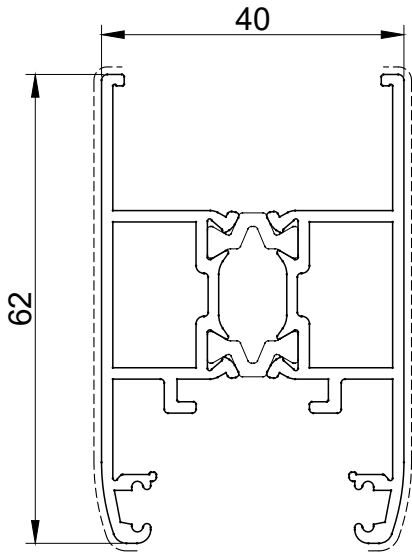

B 061304

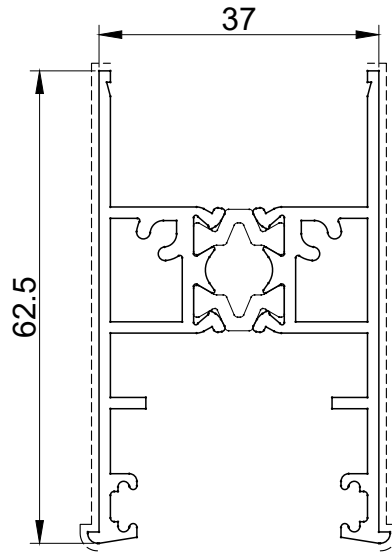



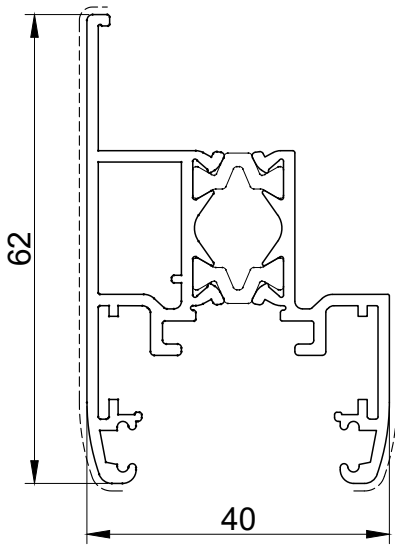

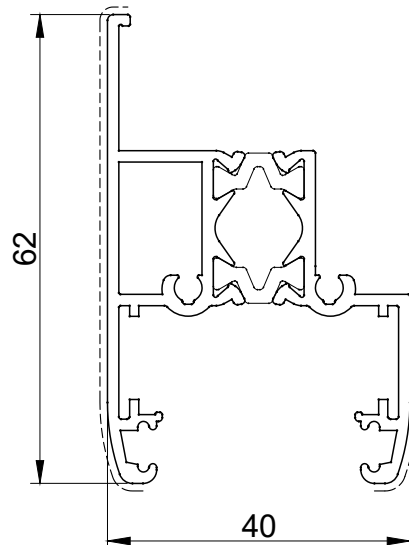

B 061314



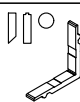



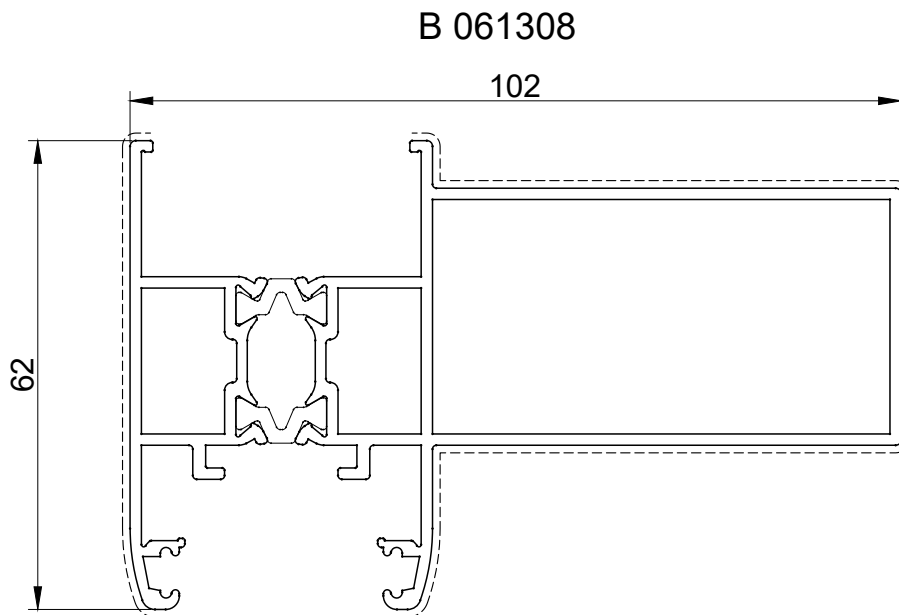
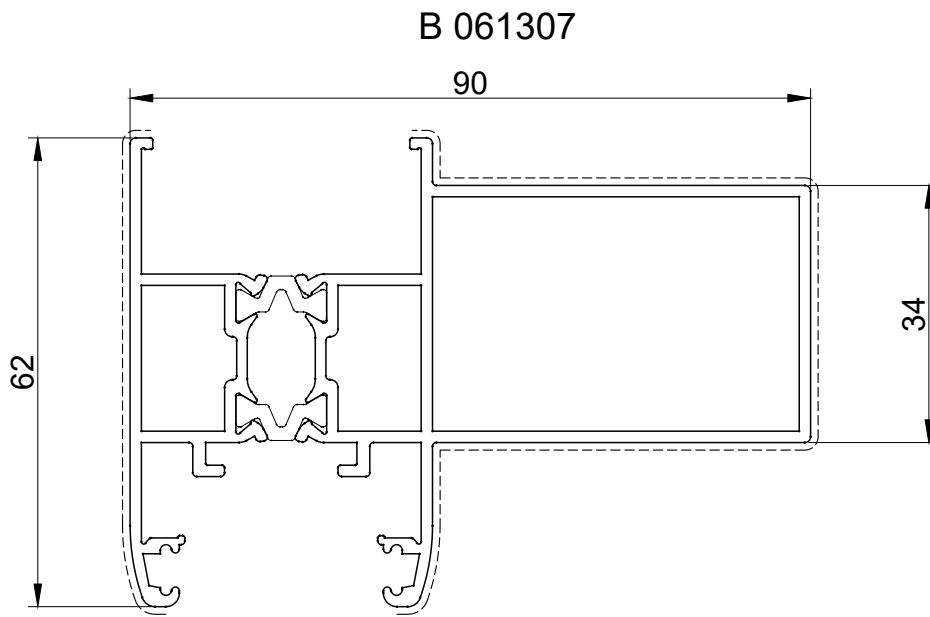

B 061315









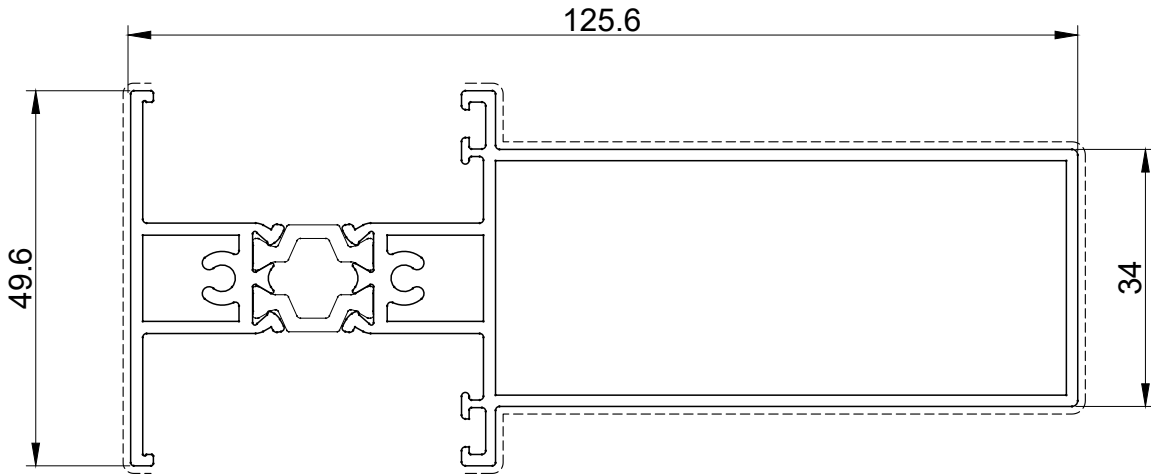

<ul style="list-style-type: none">  crimpable  nailable  retro gluing after assembly 	chamber			
				
B 061303	-	-	-	-
B 061304	-	-	2x Z 901499 / 2x Z 913239	-
B 061314	-	-	-	-
B 061315	-	-	2x Z 901499 / 2x Z 913239	-



<ul style="list-style-type: none">  crimpable  nailable  retro gluing after assembly 	chamber			
				
B 061307	-	-	-	-
B 061308	-	-	-	-







B 061310

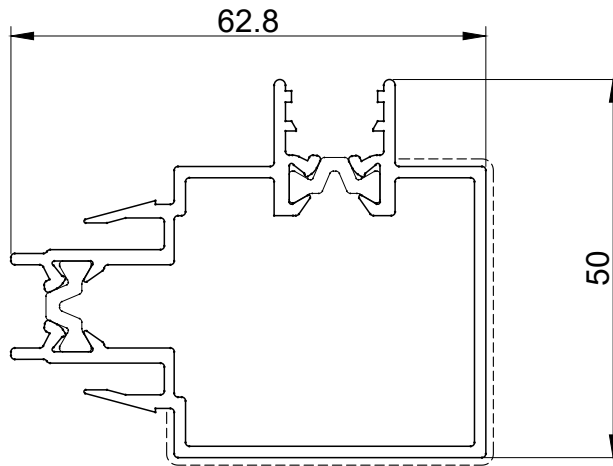

<ul style="list-style-type: none">  crimpable  nailable  retro gluing after assembly 	chamber			
				
B 061303	-	-	2x Z 901499	-

B 061306



<ul style="list-style-type: none">  crimpable  nailable  retro gluing after assembly 	chamber			
				
B 061306	-	-	2x Z 901499	-
B 000000	-	-	-	-

P 061108

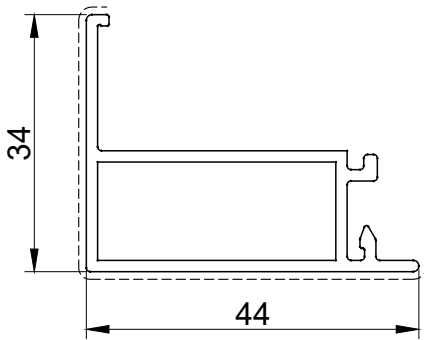

P 061109

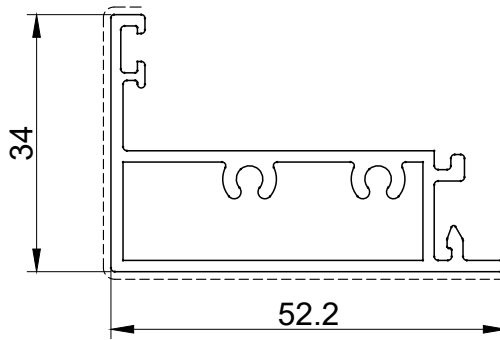



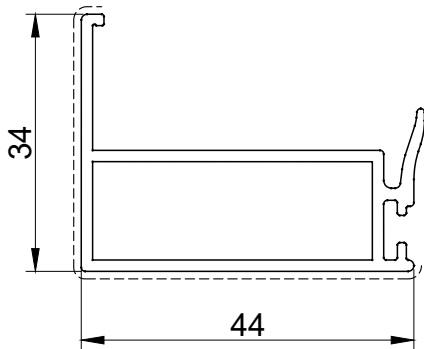

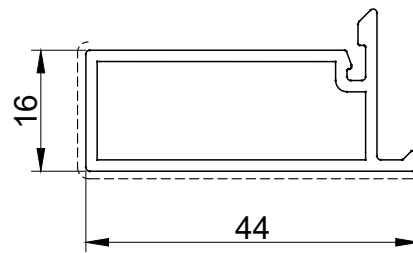

P 061149



P 061150







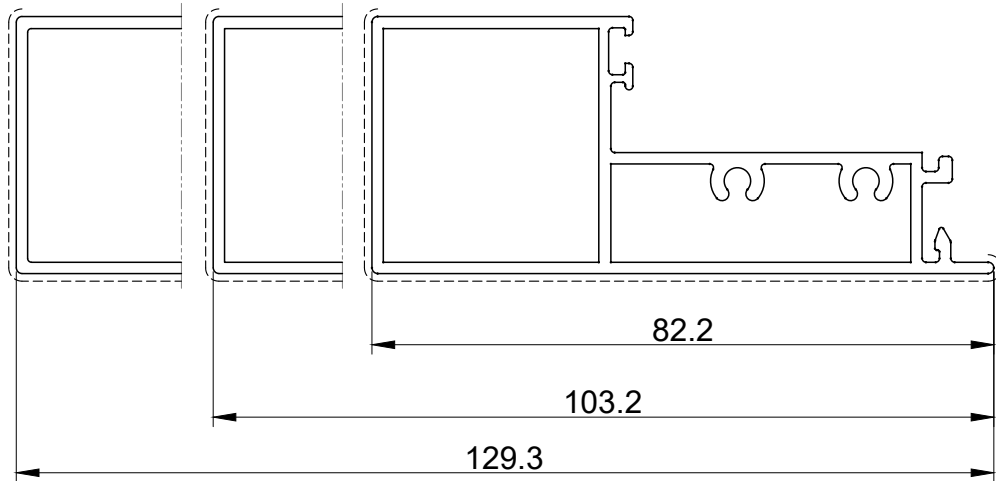

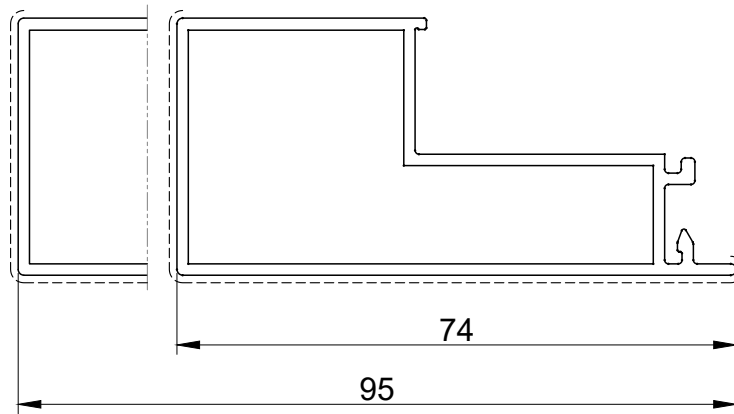

<ul style="list-style-type: none">  crimpable  nailable  retro gluing after assembly 	chamber			
				
P 061108	-	-	-	-
P 061109	-	-	2x Z 913239	-
P 061149	-	-	-	-
P 061150	-	-	-	-

P 061128 P 061134 P 061153



P 061111 P 061152



<ul style="list-style-type: none">  crimpable  nailable  retro gluing after assembly 	chamber			
				
P 000000	-	-	2x Z 913239	-
P 061134	-	-	2x Z 913239	-
P 061128	-	-	2x Z 913239	-
P 000000	-	-	-	-
P 061111	-	-	-	-

P 061116

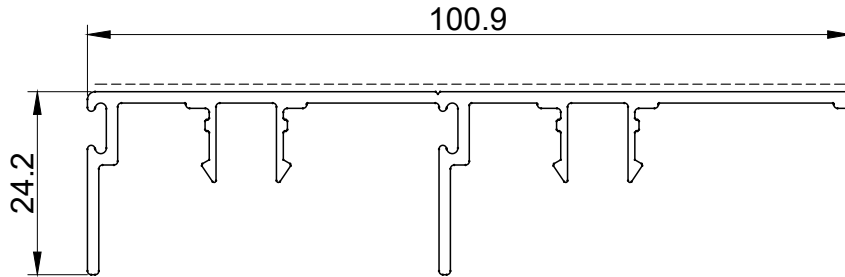

P 061143

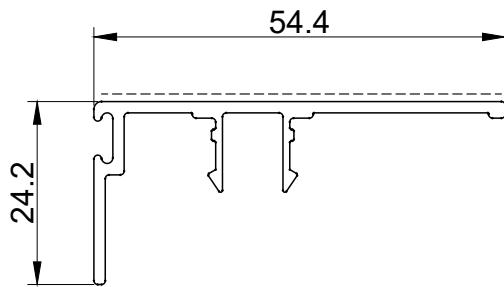

P 061115

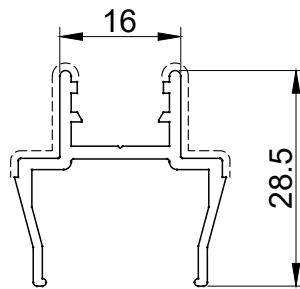

H062007

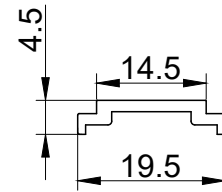

P 061135

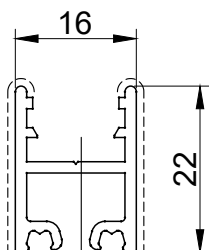

P 061138

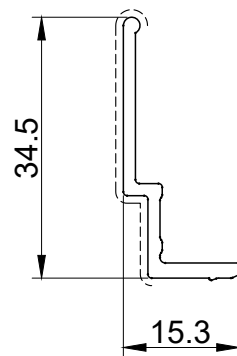

P 061139

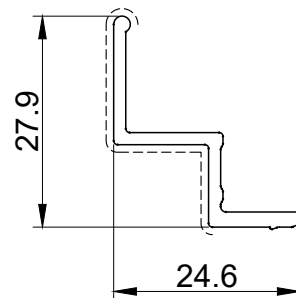

P 599343

artical no.:	profile no.:	length
P 599343	Z 663033	11.1 mm

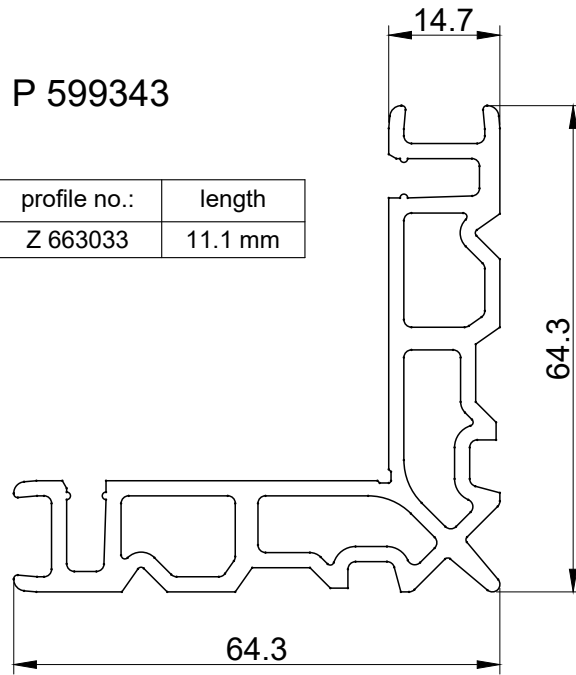

P 499605

artical no.:	profile no.:	length
P 499605	Z 061505	39.7 mm
P 499605	Z 061506	32.7 mm
P 499605	Z 061507	26.5 mm

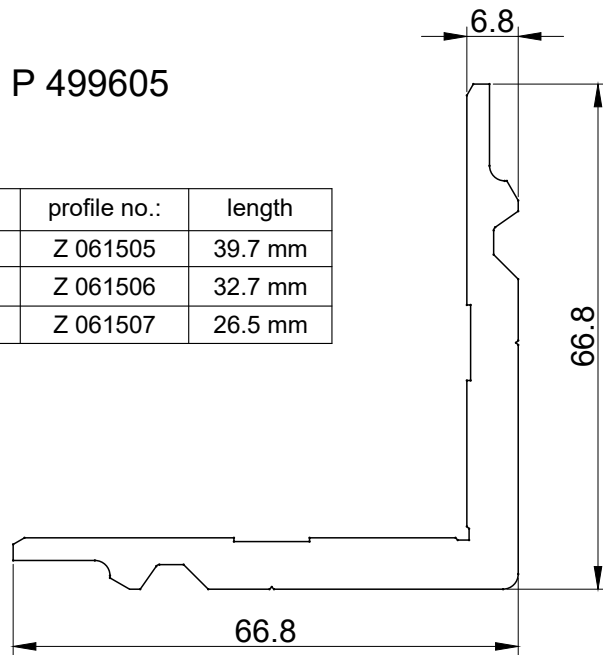

P 816600

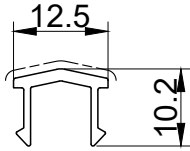

P 061112

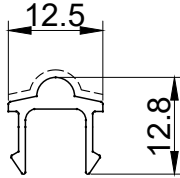

P 061140

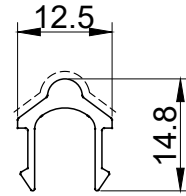

P 061107

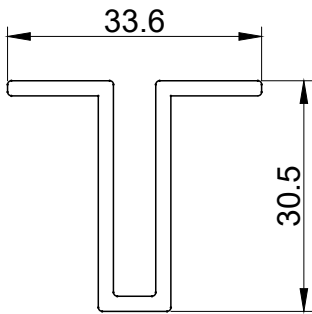

P 660055

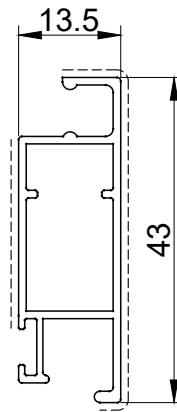

P 061151

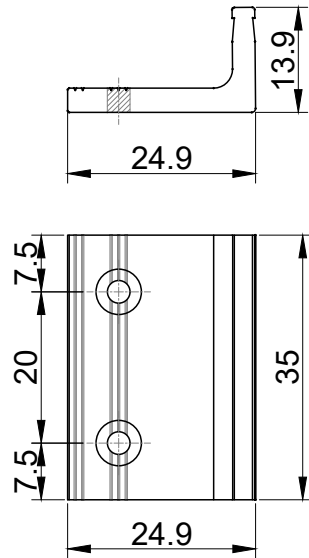

P 061117

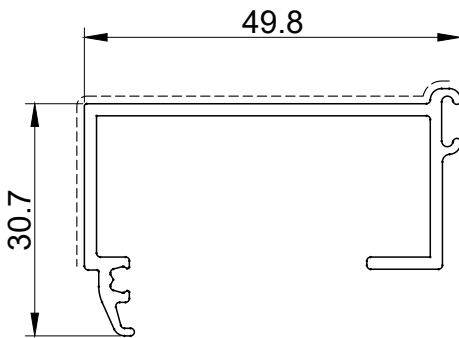

P 499760

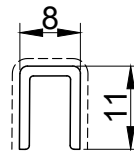

P 061136

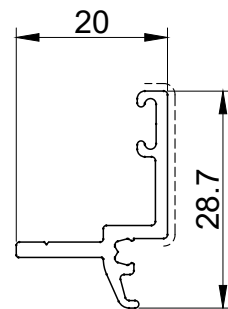

P 061122

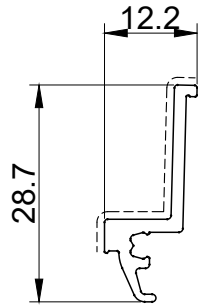

P 061123

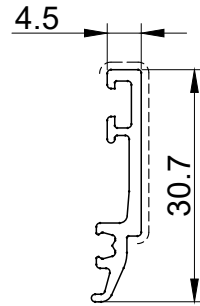

P 816603

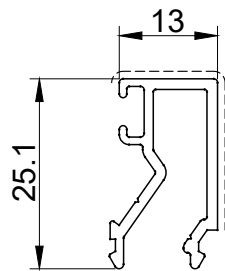

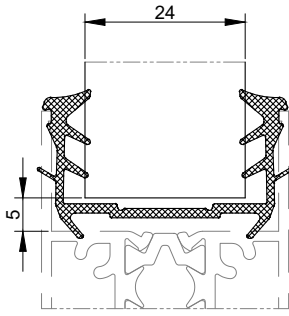
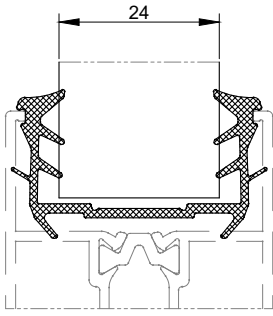
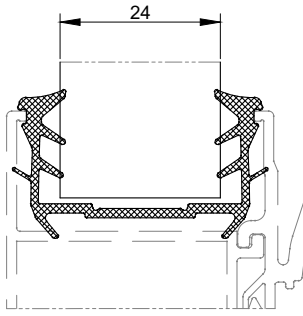
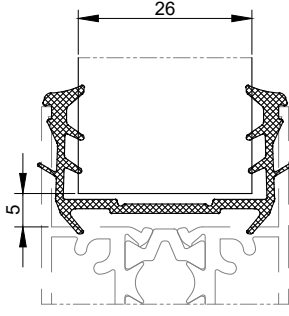
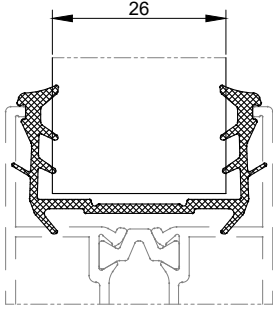
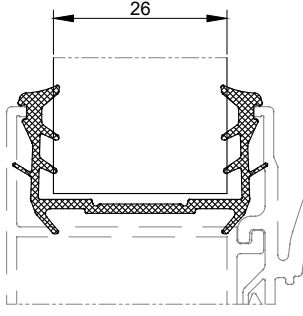
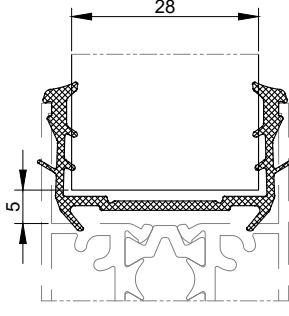
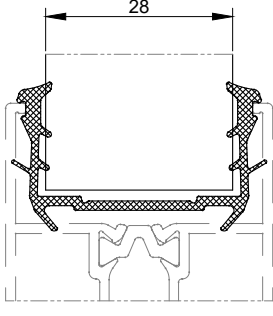
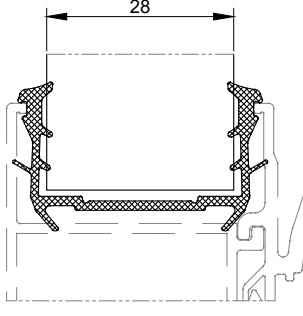
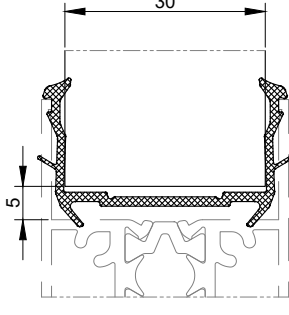
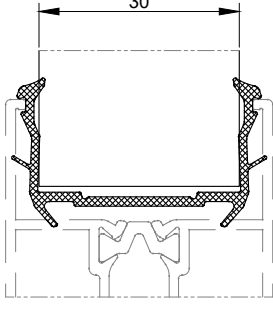
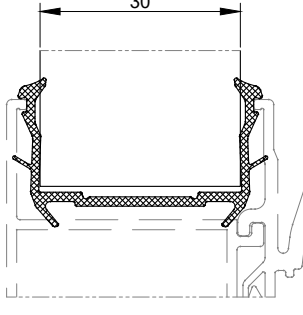
Glazing gasket	Glass thickness in mm	Variants of profiles		
Z 061808	24			
Z 061800	26			
Z 061811	28			
Z 061803	30			

The specified panel thicknesses are nominal dimensions. When selecting the inner gasket, glass- and profile tolerances must be regarded. Possibly the next smaller or bigger inner gasket should be included.

Glazing gaskets for glazing beads

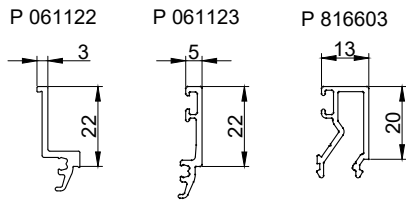

Glazing gaskets	external				internal		
					(A) 	(B) 	(C)
Art. no.	Z 918350	Z 912611	Z 912612	Z 912613	Z 914259	Z 914260	Z 914261
Gap dimension	2	4	6	8	4.5 - 6.5	5.5 - 7.5	6.5 - 9.5

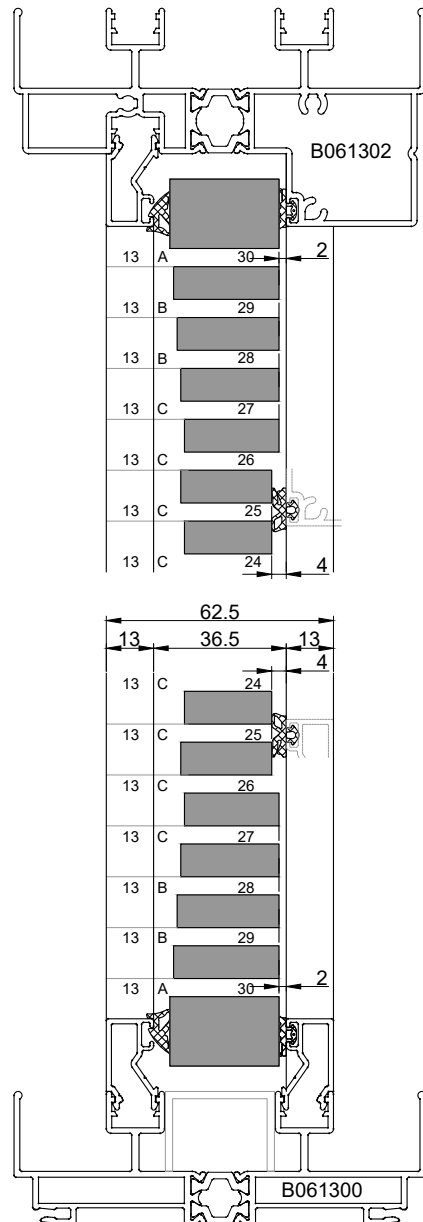
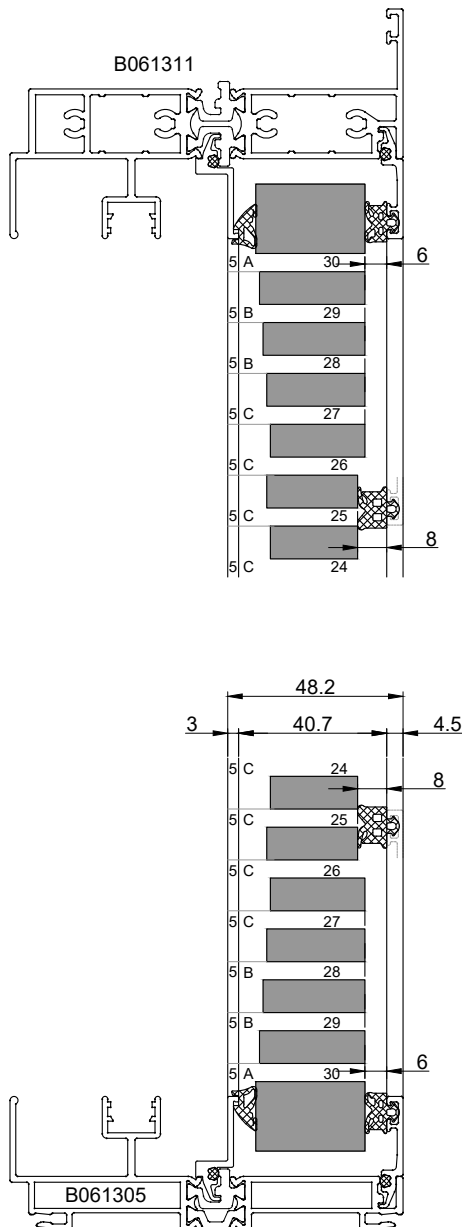

Glazing

The specified panel thicknesses are nominal dimensions. When selecting the inner gasket, glass- and profile tolerances must be regarded. Possibly the next smaller or bigger inner gasket should be included.

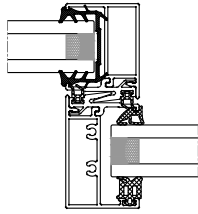

COMBINATION - A

Profile Inertia of P 061108	=	4.2 cm ⁴
Profile Inertia of P 061109	=	7.5 cm ⁴
Total Inertia	=	11.7 cm⁴

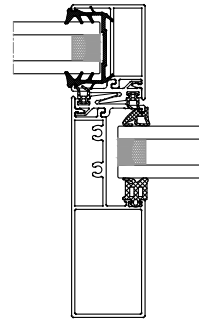

COMBINATION - D

Profile Inertia of P 061108	=	4.2 cm ⁴
Profile Inertia of P 061134	=	45.2 cm ⁴
Total Inertia	=	49.4 cm⁴

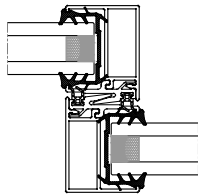

COMBINATION - B

Profile Inertia of P 061108	=	4.2 cm ⁴
Profile Inertia of P 061108	=	4.2 cm ⁴
Total Inertia	=	8.4 cm⁴

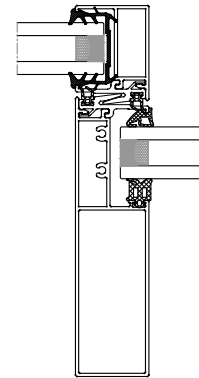

COMBINATION - E

Profile Inertia of P 061108	=	4.2 cm ⁴
Profile Inertia of P 061128	=	87.2 cm ⁴
Total Inertia	=	91.4 cm⁴

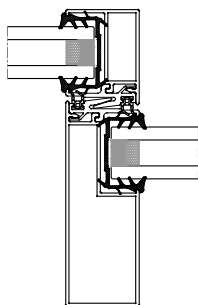

COMBINATION - C

Profile Inertia of P 061108	=	4.2 cm ⁴
Profile Inertia of P 061111	=	34.3 cm ⁴
Total Inertia	=	38.5 cm⁴

VOLATO SL-40 ISO Interlock Style structural analysis without steel Reinforcement

For 1.2 kpa Windpressure Ridity - maximum deflection should not exceed: L/175

L	Ixx (cm ⁴), Structural profile depth color table									
	164.00	182.20	200.50	218.70	236.90	255.10	273.40	291.60	309.80	328.00
3600	164.00	182.20	200.50	218.70	236.90	255.10	273.40	291.60	309.80	328.00
3500	150.70	167.50	184.20	201.00	217.70	234.50	251.20	268.00	284.70	301.50
3400	138.20	153.50	168.90	184.20	199.60	214.90	230.30	245.60	261.00	276.40
3300	126.30	140.40	154.40	168.50	182.50	196.50	210.60	224.60	238.60	252.70
3200	115.20	128.00	140.80	153.60	166.40	179.20	192.00	204.80	217.60	230.40
3100	104.70	116.40	128.00	139.60	151.30	162.90	174.60	186.20	197.80	209.50
3000	94.90	105.50	116.00	126.60	137.10	147.70	158.20	168.80	179.30	189.80
2900	85.70	95.30	104.80	114.30	123.90	133.40	142.90	152.40	162.00	171.50
2800	77.20	85.70	94.30	102.90	111.50	120.00	128.60	137.20	145.80	154.30
2700	69.20	76.90	84.60	92.30	100.00	107.60	115.30	123.00	130.70	138.40
2600	61.80	68.70	75.50	82.40	89.30	96.10	103.00	109.90	116.70	123.60
2500	54.90	61.00	67.10	73.20	79.30	85.40	91.60	97.70	103.80	109.90
2400	48.60	54.00	59.40	64.80	70.20	75.60	81.00	86.40	91.80	97.20
2300	42.80	47.50	52.30	57.00	61.80	66.50	71.30	76.00	80.80	85.50
2200	37.40	41.60	45.80	49.90	54.10	58.20	62.40	66.60	70.70	74.90
2100	32.60	36.20	39.80	43.40	47.00	50.60	54.30	57.90	61.50	65.10
2000	28.10	31.30	34.40	37.50	40.60	43.70	46.90	50.00	53.10	56.30
1900	24.10	26.80	29.50	32.20	34.80	37.50	40.20	42.90	45.50	48.20
1800	20.50	22.80	25.10	27.30	29.60	31.90	34.20	36.50	38.70	41.00
1700	17.30	19.20	21.10	23.00	24.90	26.90	28.80	30.70	32.60	
1600	14.40	16.00	17.60	19.20	20.80	22.40	24.00	25.60		
1500	11.90	13.20	14.50	15.80	17.10	18.50	19.80			
1400	9.60	10.70	11.80	12.90	13.90	15.00				
1300	7.70	8.60	9.40	10.30	11.20					
1200	6.10	6.70	7.40	8.10						
1100	4.70	5.20	5.70							
1000	3.50	3.90								
900	2.60									
Height	900	1000	1100	1200	1300	1400	1500	1600	1700	1800
Width										

**It is advised always to consider Height to Width ratio - 2.5/1

Colour Legend		Ixx Value
Combination - A		8.40 cm ⁴
Combination - B		11.70 cm ⁴
Combination - C		38.50 cm ⁴
Combination - D		49.40 cm ⁴
Combination - E		91.40 cm ⁴

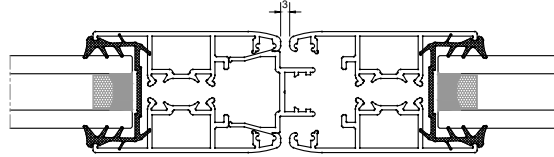

COMBINATION - A

Profile Inertia of B 061303 = 7.6 cm⁴
 Profile Inertia of B 061303 + P 061115 = 8.4 cm⁴

Total Inertia = 16 cm⁴

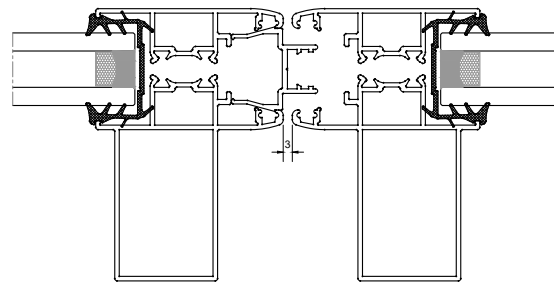

COMBINATION - B

Profile Inertia of B 061307 = 39.30 cm⁴
 Profile Inertia of B 061307 + P 061115 = 42.24 cm⁴

Total Inertia = 81.54 cm⁴

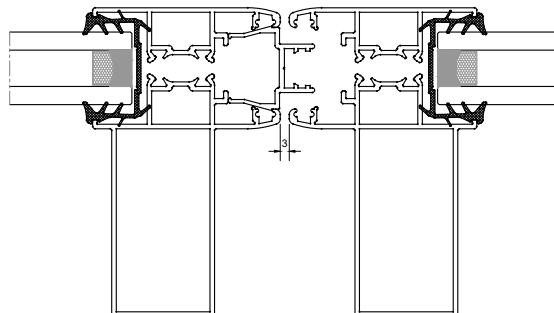

COMBINATION - C

Profile Inertia of B 061308 = 54.00 cm⁴
 Profile Inertia of B 061308 + P061115 = 58.28 cm⁴

Total Inertia = 112.28 cm⁴

VOLATO SL-40 ISO Meeting Style structural analysis without steel Reinforcement

Rigidity - maximum deflection should not exceed: L/175

For 1.2 kpa Windpressure

L	I _{xx} (cm ⁴), Structural profile depth color table																				
	164.00	182.20	200.50	218.70	236.90	255.10	273.40	291.60	309.80	328.00	164.00	182.20	200.50	218.70	236.90	255.10	273.40	291.60	309.80	328.00	
3500	150.70	167.50	184.20	201.00	217.70	234.50	251.20	268.00	284.70	301.50	150.70	167.50	184.20	201.00	217.70	234.50	251.20	268.00	284.70	301.50	
3400	138.20	153.50	168.90	184.20	199.60	214.90	230.30	245.60	261.00	276.40	138.20	153.50	168.90	184.20	199.60	214.90	230.30	245.60	261.00	276.40	
3300	126.30	140.40	154.40	168.50	182.50	196.50	210.60	224.60	238.60	252.70	126.30	140.40	154.40	168.50	182.50	196.50	210.60	224.60	238.60	252.70	
3200	115.20	128.00	140.80	153.60	166.40	179.20	192.00	204.80	217.60	230.40	115.20	128.00	140.80	153.60	166.40	179.20	192.00	204.80	217.60	230.40	
3100	104.70	116.40	128.00	139.60	151.30	162.90	174.60	186.20	197.80	209.50	104.70	116.40	128.00	139.60	151.30	162.90	174.60	186.20	197.80	209.50	
3000	94.90	105.50	116.00	126.60	137.10	147.70	158.20	168.80	179.30	189.80	94.90	105.50	116.00	126.60	137.10	147.70	158.20	168.80	179.30	189.80	
2900	85.70	95.30	104.80	114.30	123.90	133.40	142.90	152.40	162.00	171.50	85.70	95.30	104.80	114.30	123.90	133.40	142.90	152.40	162.00	171.50	
2800	77.20	85.70	94.30	102.90	111.50	120.00	128.60	137.20	145.80	154.30	77.20	85.70	94.30	102.90	111.50	120.00	128.60	137.20	145.80	154.30	
2700	69.20	76.90	84.60	92.30	100.00	107.60	115.30	123.00	130.70	138.40	69.20	76.90	84.60	92.30	100.00	107.60	115.30	123.00	130.70	138.40	
2600	61.80	68.70	75.50	82.40	89.30	96.10	103.00	109.90	116.70	123.60	61.80	68.70	75.50	82.40	89.30	96.10	103.00	109.90	116.70	123.60	
2500	54.90	61.00	67.10	73.20	79.30	85.40	91.60	97.70	103.80	109.90	54.90	61.00	67.10	73.20	79.30	85.40	91.60	97.70	103.80	109.90	
2400	48.60	54.00	59.40	64.80	70.20	75.60	81.00	86.40	91.80	97.20	48.60	54.00	59.40	64.80	70.20	75.60	81.00	86.40	91.80	97.20	
2300	42.80	47.50	52.30	57.00	61.80	66.50	71.30	76.00	80.80	85.50	42.80	47.50	52.30	57.00	61.80	66.50	71.30	76.00	80.80	85.50	
2200	37.40	41.60	45.80	49.90	54.10	58.20	62.40	66.60	70.70	74.90	37.40	41.60	45.80	49.90	54.10	58.20	62.40	66.60	70.70	74.90	
2100	32.60	36.20	39.80	43.40	47.00	50.60	54.30	57.90	61.50	65.10	32.60	36.20	39.80	43.40	47.00	50.60	54.30	57.90	61.50	65.10	
2000	28.10	31.30	34.40	37.50	40.60	43.70	46.90	50.00	53.10	56.30	28.10	31.30	34.40	40.60	43.70	46.90	50.00	53.10	56.30	59.50	
1900	24.10	26.80	29.50	32.20	34.80	37.50	40.20	42.90	45.50	48.20	24.10	26.80	29.50	32.20	34.80	37.50	40.20	42.90	45.50	48.20	
1800	20.50	22.80	25.10	27.30	29.60	31.90	34.20	36.50	38.70	41.00	20.50	22.80	25.10	27.30	29.60	31.90	34.20	36.50	38.70	41.00	
1700	17.30	19.20	21.10	23.00	24.90	26.90	28.80	30.70	32.60		17.30	19.20	21.10	23.00	24.90	26.90	28.80	30.70	32.60		
1600	14.40	16.00	17.60	19.20	20.80	22.40	24.00	25.60			14.40	16.00	17.60	19.20	20.80	22.40	24.00	25.60			
1500	11.90	13.20	14.50	15.80	17.10	18.50	19.80				11.90	13.20	14.50	15.80	17.10	18.50	19.80				
1400	9.60	10.70	11.80	12.90	13.90	15.00					9.60	10.70	11.80	12.90	13.90	15.00					
1300	7.70	8.60	9.40	10.30	11.20						7.70	8.60	9.40	10.30	11.20						
1200	6.10	6.70	7.40	8.10							6.10	6.70	7.40	8.10							
1100	4.70	5.20	5.70								4.70	5.20	5.70								
1000	3.50	3.90									3.50	3.90									
900	2.60										2.60										
"Height	900	1000	1100	1200	1300	1400	1500	1600	1700	1800	900	1000	1100	1200	1300	1400	1500	1600	1700	1800	
Width"																					

**It is advised always to consider Height to Width ratio - 2.5/1

Colour Legend	I _{xx} Value
Combination - A	16.00 cm ⁴
Combination - B	81.54 cm ⁴
Combination - C	112.28 cm ⁴



HUECK

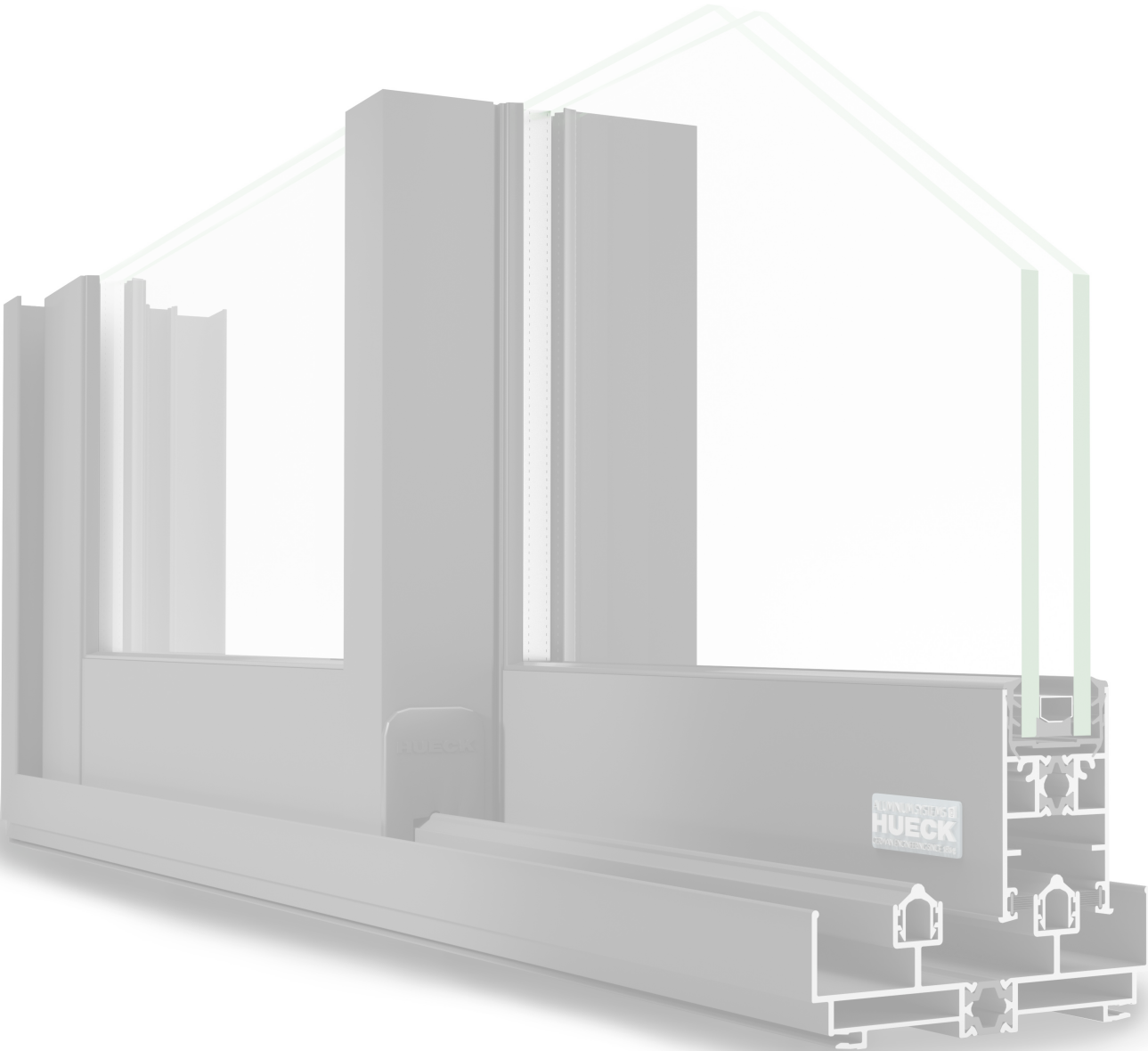

12/2022

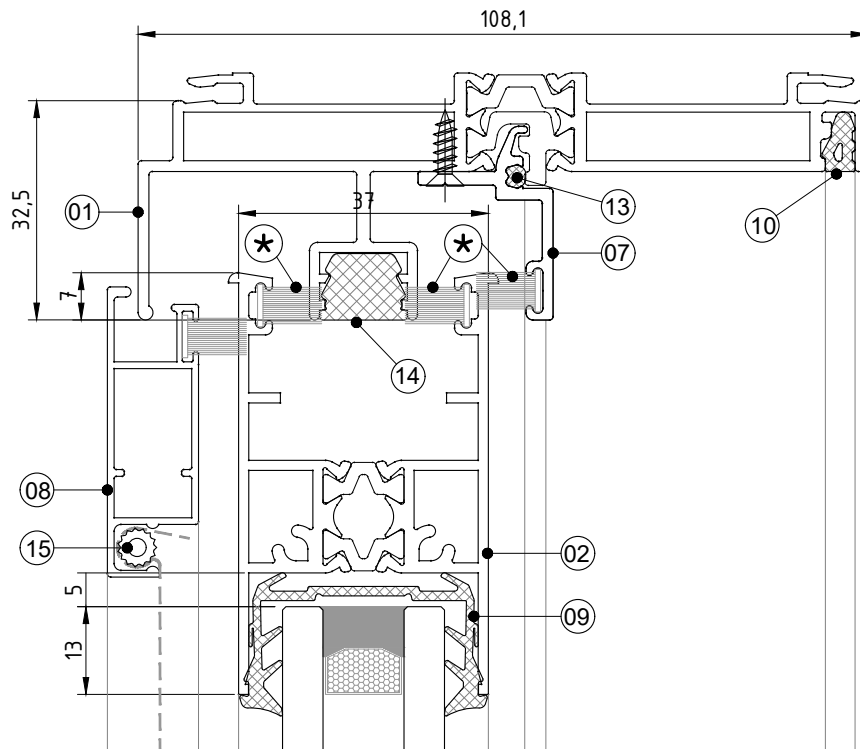
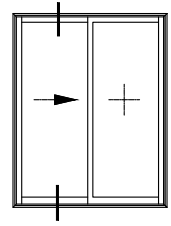

- | | | |
|---|----------------------|-------------|
| ① | Frame | B 061305 |
| ② | Sash | B 061304 |
| ③ | Sash | B 061303 |
| ④ | Sash | P 061108*** |
| ⑤ | Sash | P 061109*** |
| ⑥ | Rail | P 061140 |
| ⑦ | Top Barrier | P 061136 |
| ⑧ | Flymesh Sash | P 660055 |
| ⑨ | Glazing gasket | Z 061808*** |
| ⑩ | Groove Gasket | Z 061807 |
| ⑪ | Cover Gasket | Z 061806 |
| ⑫ | Woven pile | Z 061812 |
| ⑬ | Gasket cord | Z 902161 |
| ⑭ | Cover foam | Z 060811 |
| ⑮ | PVC Gasket | Z 918565 |
| ⑯ | Beading in | Z 061122 |
| ⑰ | Beading out | Z 061123 |
| ⑱ | Glazing gasket in | Z 914261*** |
| ⑲ | Glazing gasket out | Z 912612*** |
| ⑳ | Interlock gasket | Z 061815 |
| ㉑ | PVC interlock | K 061001 |
| ㉒ | Shaped plastic piece | Z 061503 |

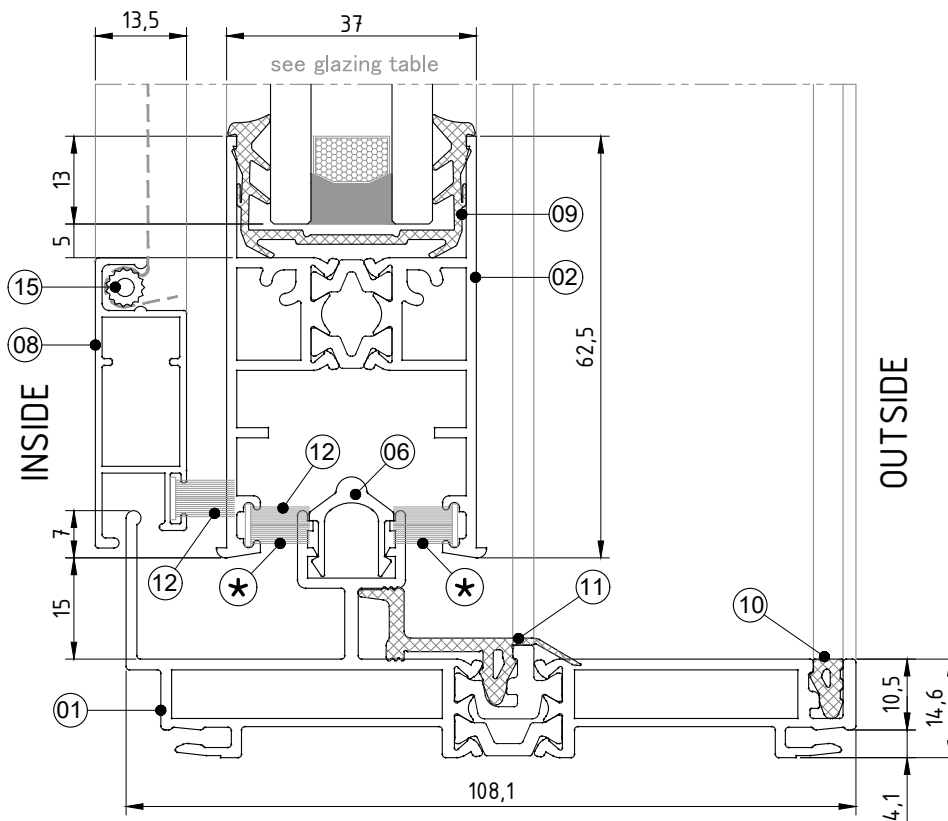

*** optional item
 ⊕ for high performance use bulb gasket (Z 913154) instead of brush

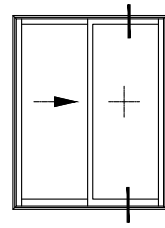
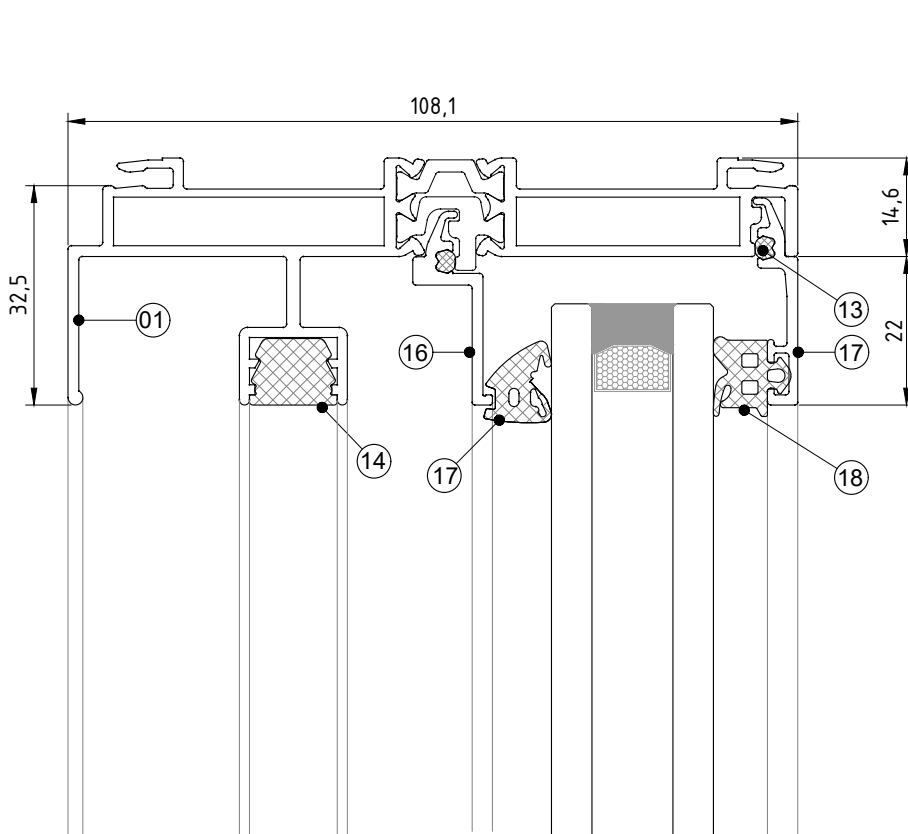

- | | | |
|---|----------------------|-------------|
| ① | Frame | B 061305 |
| ② | Sash | B 061304 |
| ③ | Sash | B 061303 |
| ④ | Sash | P 061108*** |
| ⑤ | Sash | P 061109*** |
| ⑥ | Rail | P 061140 |
| ⑦ | Top Barrier | P 061136 |
| ⑧ | Flymesh Sash | P 660055 |
| ⑨ | Glazing gasket | Z 061808*** |
| ⑩ | Groove Gasket | Z 061807 |
| ⑪ | Cover Gasket | Z 061806 |
| ⑫ | Woven pile | Z 061812 |
| ⑬ | Gasket cord | Z 902161 |
| ⑭ | Cover foam | Z 060811 |
| ⑮ | PVC Gasket | Z 918565 |
| ⑯ | Beading in | Z 061122 |
| ⑰ | Beading out | Z 061123 |
| ⑱ | Glazing gasket in | Z 914261*** |
| ⑲ | Glazing gasket out | Z 912612*** |
| ⑳ | Interlock gasket | Z 061815 |
| ㉑ | PVC interlock | K 061001 |
| ㉒ | Shaped plastic piece | Z 061503 |

Sections / Details

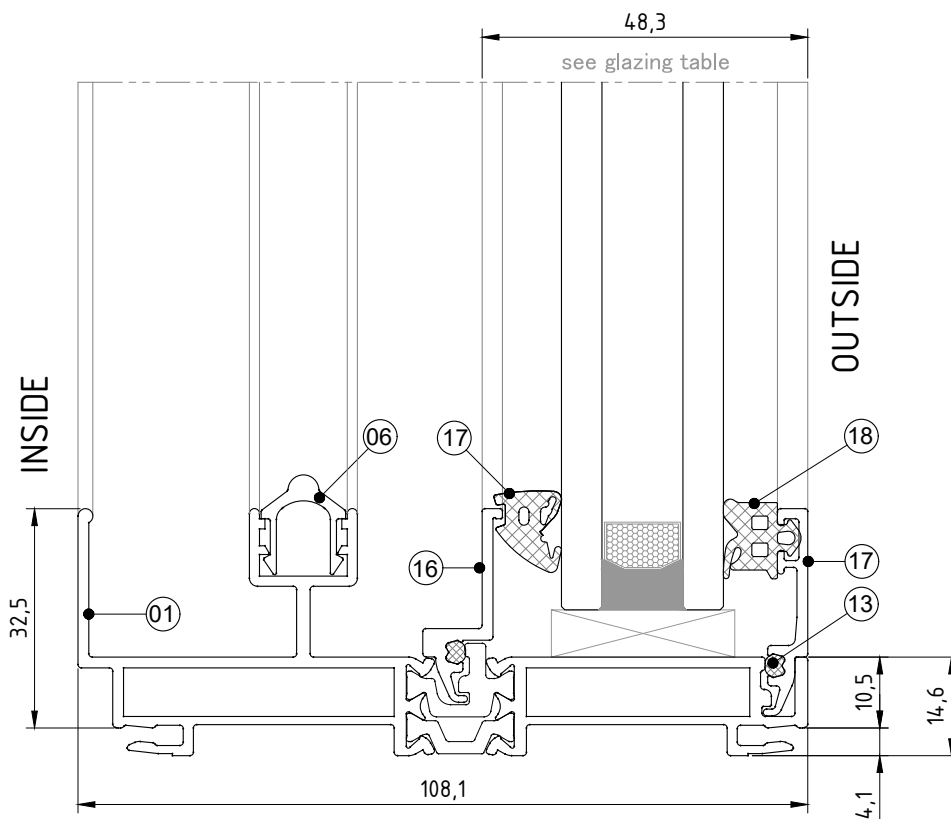

*** optional item
 * for high performance use bulb gasket (Z 913154) instead of brush

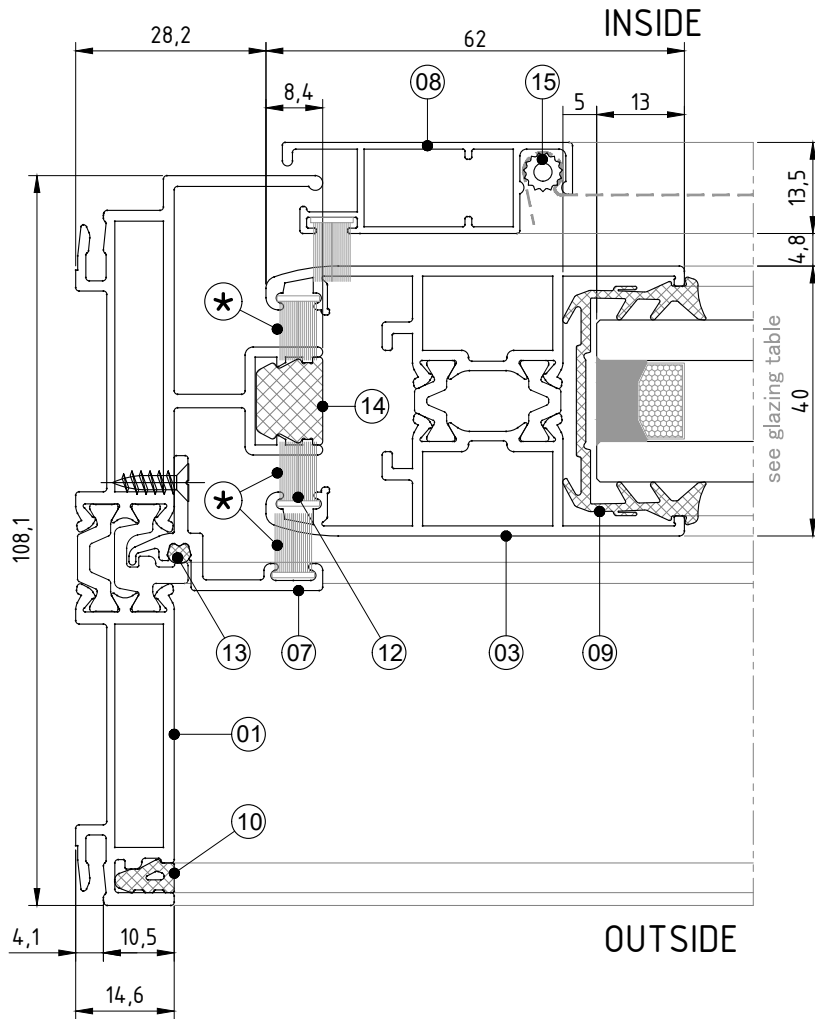
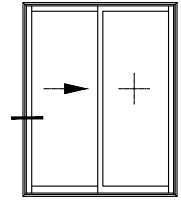

①	Frame	B 061305
②	Sash	B 061304
③	Sash	B 061303
④	Sash	P 061108***
⑤	Sash	P 061109***
⑥	Rail	P 061140
⑦	Top Barrier	P 061136
⑧	Flymesh Sash	P 660055
⑨	Glazing gasket	Z 061808***
⑩	Groove Gasket	Z 061807
⑪	Cover Gasket	Z 061806
⑫	Woven pile	Z 061812
⑬	Gasket cord	Z 902161
⑭	Cover foam	Z 060811
⑮	PVC Gasket	Z 918565
⑯	Beading in	Z 061122
⑰	Beading out	Z 061123
⑱	Glazing gasket in	Z 914261***
⑲	Glazing gasket out	Z 912612***
⑳	Interlock gasket	Z 061815
㉑	PVC interlock	K 061001
㉒	Shaped plastic piece	Z 061503

*** optional item

⊕ for high performance use bulb gasket (Z 913154) instead of brush



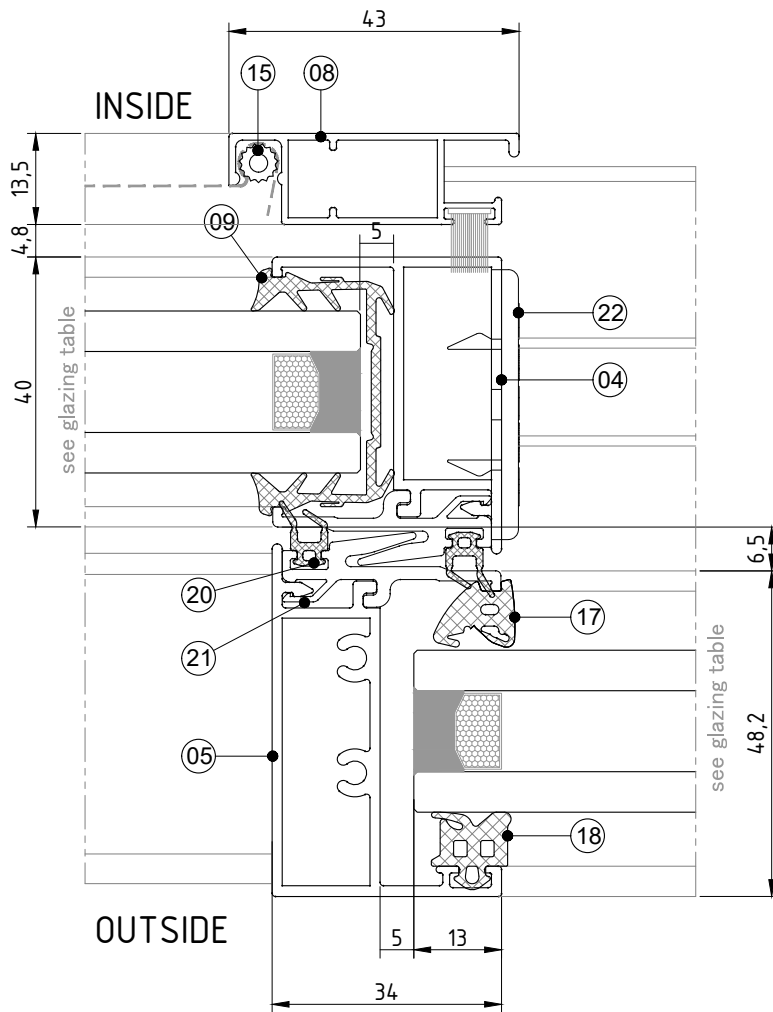
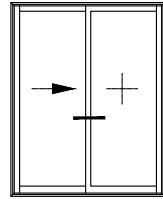

①	Frame	B 061305
②	Sash	B 061304
③	Sash	B 061303
④	Sash	P 061108***
⑤	Sash	P 061109***
⑥	Rail	P 061140
⑦	Top Barrier	P 061136
⑧	Flymesh Sash	P 660055
⑨	Glazing gasket	Z 061808***
⑩	Groove Gasket	Z 061807
⑪	Cover Gasket	Z 061806
⑫	Woven pile	Z 061812
⑬	Gasket cord	Z 902161
⑭	Cover foam	Z 060811
⑮	PVC Gasket	Z 918565
⑯	Beading in	Z 061122
⑰	Beading out	Z 061123
⑱	Glazing gasket in	Z 914261***
⑲	Glazing gasket out	Z 912612***
⑳	Interlock gasket	Z 061815
㉑	PVC interlock	K 061001
㉒	Shaped plastic piece	Z 061503

*** optional item

⊛ for high performance use bulb gasket (Z 913154) instead of brush

Sections / Details

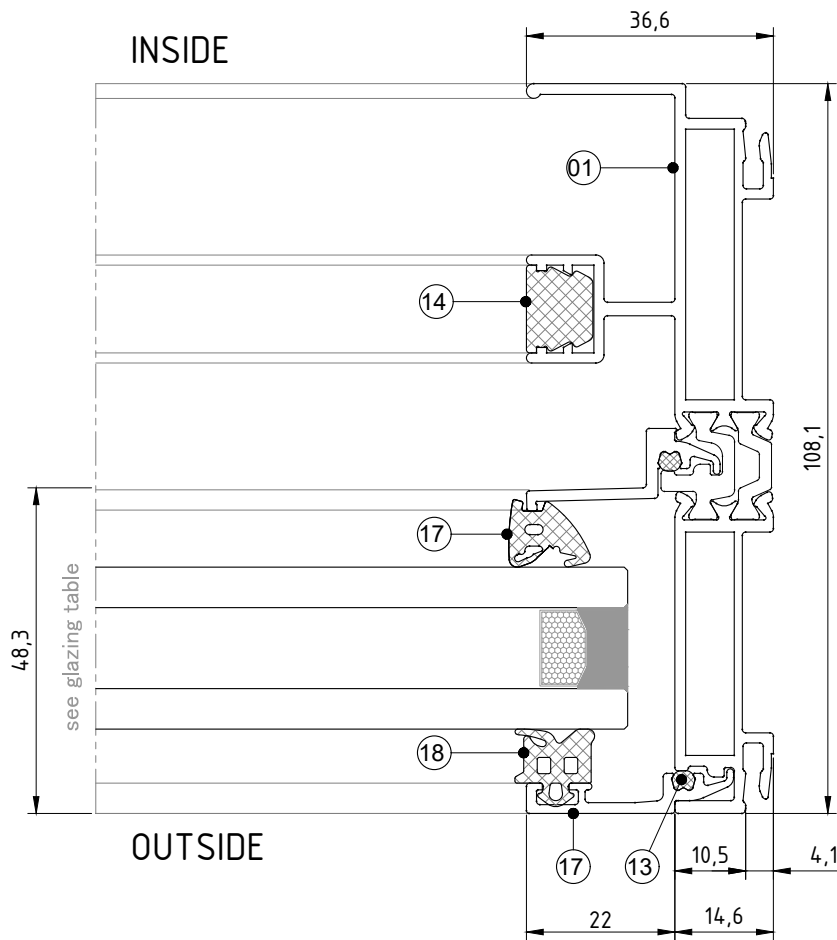
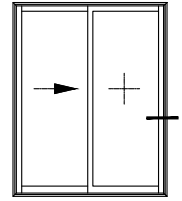

①	Frame	B 061305
②	Sash	B 061304
③	Sash	B 061303
④	Sash	P 061108***
⑤	Sash	P 061109***
⑥	Rail	P 061140
⑦	Top Barrier	P 061136
⑧	Flymesh Sash	P 660055
⑨	Glazing gasket	Z 061808***
⑩	Groove Gasket	Z 061807
⑪	Cover Gasket	Z 061806
⑫	Woven pile	Z 061812
⑬	Gasket cord	Z 902161
⑭	Cover foam	Z 060811
⑮	PVC Gasket	Z 918565
⑯	Beading in	Z 061122
⑰	Beading out	Z 061123
⑱	Glazing gasket in	Z 914261***
⑲	Glazing gasket out	Z 912612***
⑳	Interlock gasket	Z 061815
㉑	PVC interlock	K 061001
㉒	Shaped plastic piece	Z 061503

*** optional item

⊕ for high performance use bulb gasket (Z 913154) instead of brush

12/2022



Volato

Door - Double track vertical section

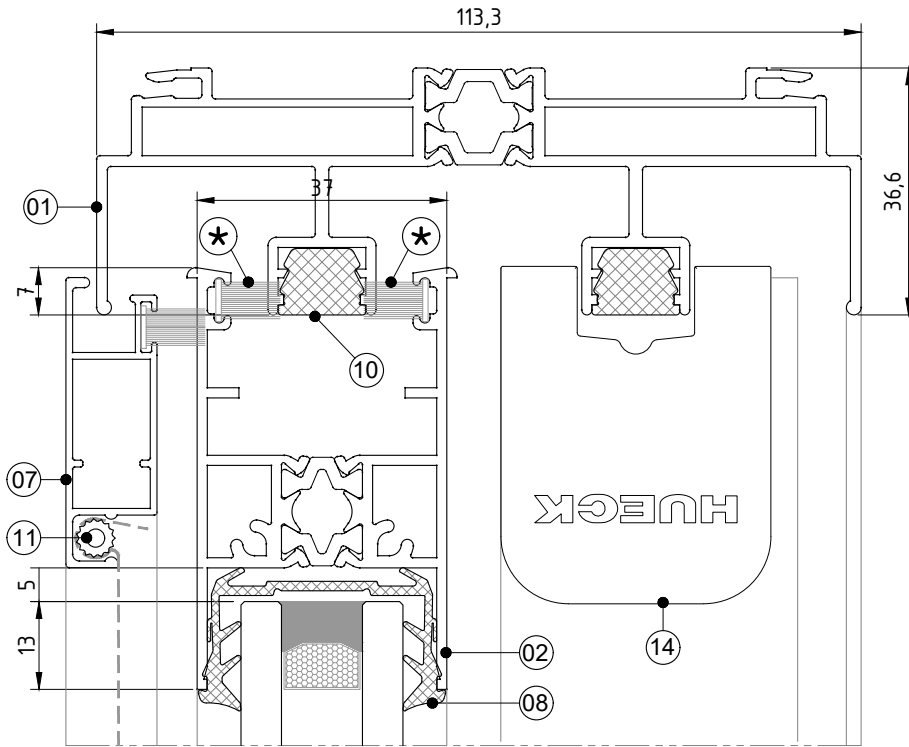
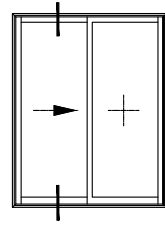

- | | | |
|---|----------------------|-------------|
| ① | Frame | B 061300 |
| ② | Sash | B 061304 |
| ③ | Sash | B 061303 |
| ④ | Sash | P 061108*** |
| ⑤ | Mid profile | P 061115 |
| ⑥ | Rail | P 061140 |
| ⑦ | Flymesh Sash | P 660055 |
| ⑧ | Glazing gasket | Z 061808*** |
| ⑨ | Woven pile | Z 061812 |
| ⑩ | Cover foam | Z 060811 |
| ⑪ | PVC Gasket | Z 918565 |
| ⑫ | Interlock gasket | Z 061815 |
| ⑬ | PVC interlock | K 061001 |
| ⑭ | Shaped plastic piece | Z 061503 |
| ⑮ | Distance piece | Z 061508 |

see glazing table

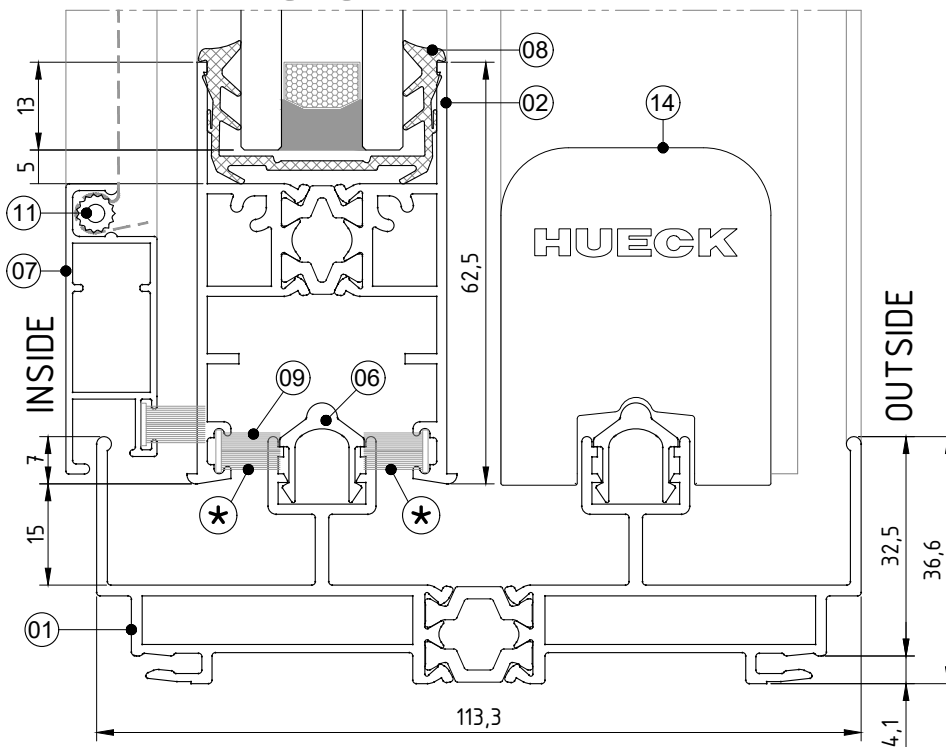

*** optional item

⊛ for high performance use bulb gasket (Z 913154) instead of brush

12/2022

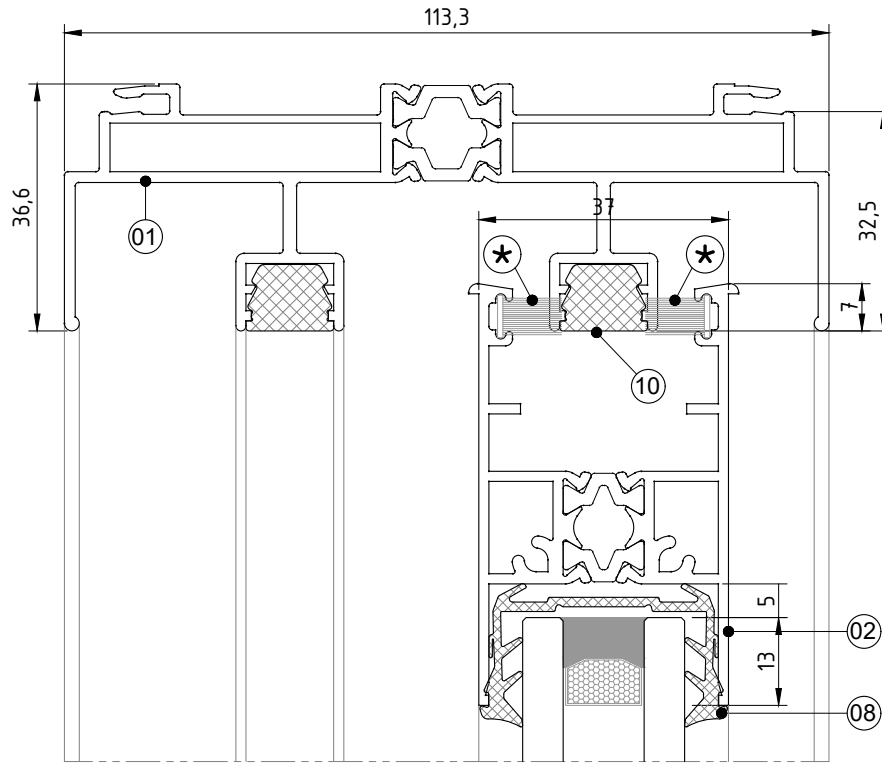
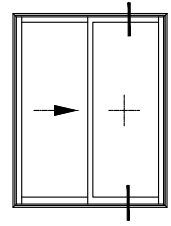

see glazing table

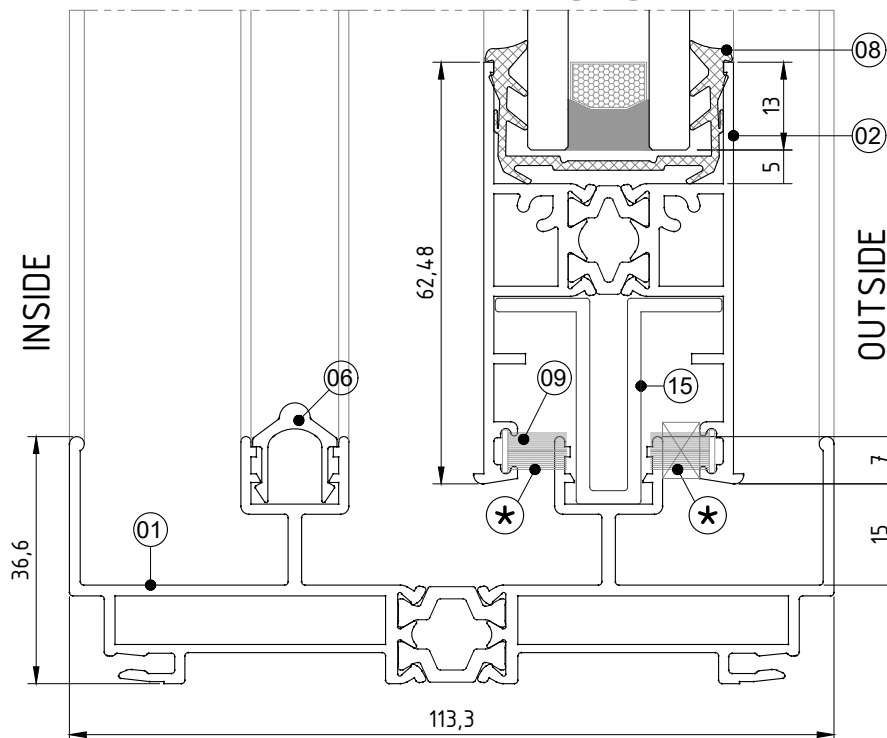

①	Frame	B 061300
②	Sash	B 061304
③	Sash	B 061303
④	Sash	P 061108***
⑤	Mid profile	P 061115
⑥	Rail	P 061140
⑦	Flymesh Sash	P 660055
⑧	Glazing gasket	Z 061808***
⑨	Woven pile	Z 061812
⑩	Cover foam	Z 060811
⑪	PVC Gasket	Z 918565
⑫	Interlock gasket	Z 061815
⑬	PVC interlock	K 061001
⑭	Shaped plastic piece	Z 061503
⑮	Distance piece	Z 061508

*** optional item

⊕ for high performance use bulb gasket (Z 913154) instead of brush



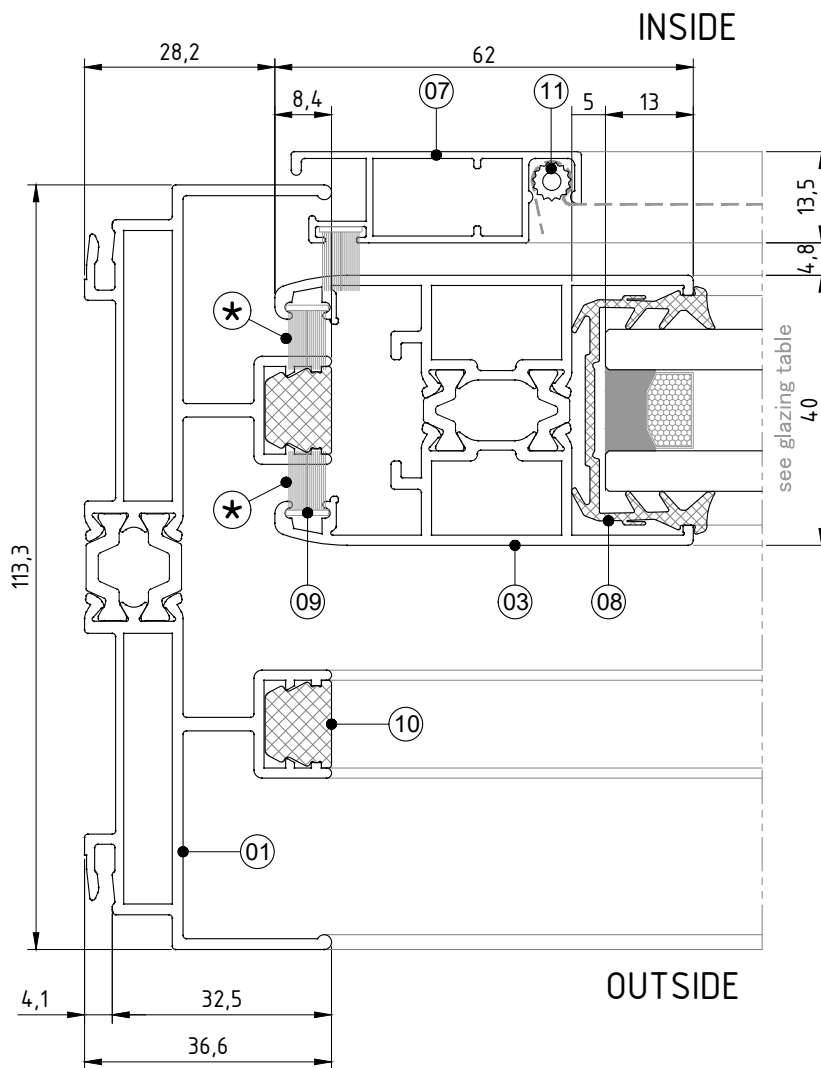
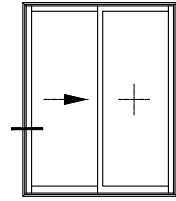

- | | | |
|---|----------------------|-------------|
| ① | Frame | B 061300 |
| ② | Sash | B 061304 |
| ③ | Sash | B 061303 |
| ④ | Sash | P 061108*** |
| ⑤ | Mid profile | P 061115 |
| ⑥ | Rail | P 061140 |
| ⑦ | Flymesh Sash | P 660055 |
| ⑧ | Glazing gasket | Z 061808*** |
| ⑨ | Woven pile | Z 061812 |
| ⑩ | Cover foam | Z 060811 |
| ⑪ | PVC Gasket | Z 918565 |
| ⑫ | Interlock gasket | Z 061815 |
| ⑬ | PVC interlock | K 061001 |
| ⑭ | Shaped plastic piece | Z 061503 |
| ⑮ | Distance piece | Z 061508 |

Sections / Details

*** optional item

⊛ for high performance use bulb gasket (Z 913154) instead of brush

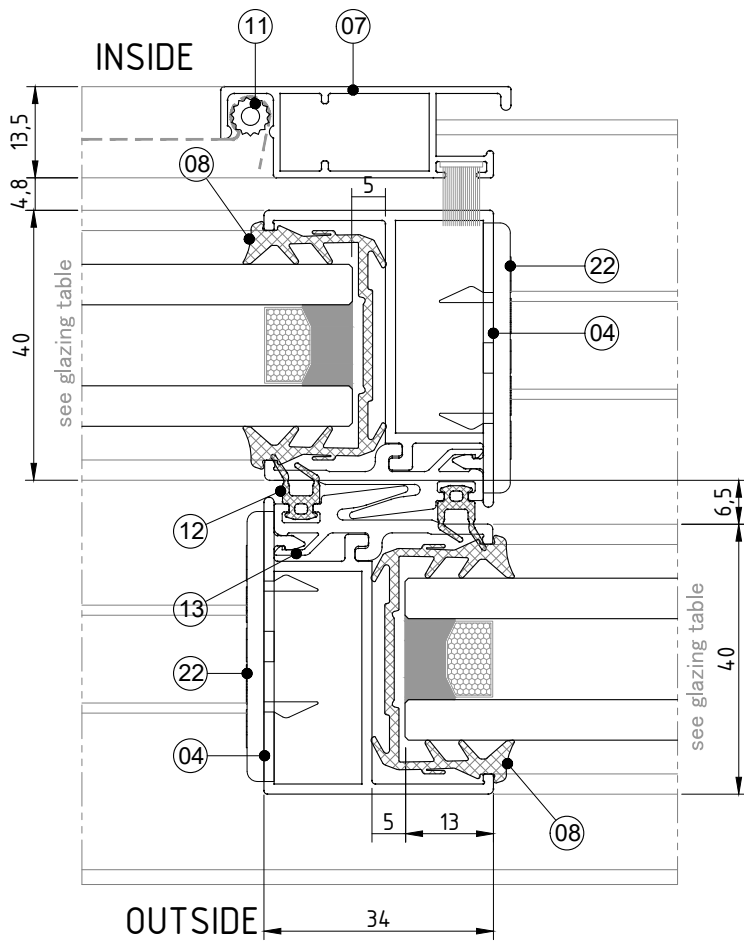
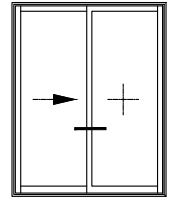

①	Frame	B 061300
②	Sash	B 061304
③	Sash	B 061303
④	Sash	P 061108***
⑤	Mid profile	P 061115
⑥	Rail	P 061140
⑦	Flymesh Sash	P 660055
⑧	Glazing gasket	Z 061808***
⑨	Woven pile	Z 061812
⑩	Cover foam	Z 060811
⑪	PVC Gasket	Z 918565
⑫	Interlock gasket	Z 061815
⑬	PVC interlock	K 061001
⑭	Shaped plastic piece	Z 061503
⑮	Distance piece	Z 061508

*** optional item

⊕ for high performance use bulb gasket (Z 913154) instead of brush



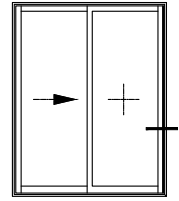

- | | | |
|---|----------------------|-------------|
| ① | Frame | B 061300 |
| ② | Sash | B 061304 |
| ③ | Sash | B 061303 |
| ④ | Sash | P 061108*** |
| ⑤ | Mid profile | P 061115 |
| ⑥ | Rail | P 061140 |
| ⑦ | Flymesh Sash | P 660055 |
| ⑧ | Glazing gasket | Z 061808*** |
| ⑨ | Woven pile | Z 061812 |
| ⑩ | Cover foam | Z 060811 |
| ⑪ | PVC Gasket | Z 918565 |
| ⑫ | Interlock gasket | Z 061815 |
| ⑬ | PVC interlock | K 061001 |
| ⑭ | Shaped plastic piece | Z 061503 |
| ⑮ | Distance piece | Z 061508 |

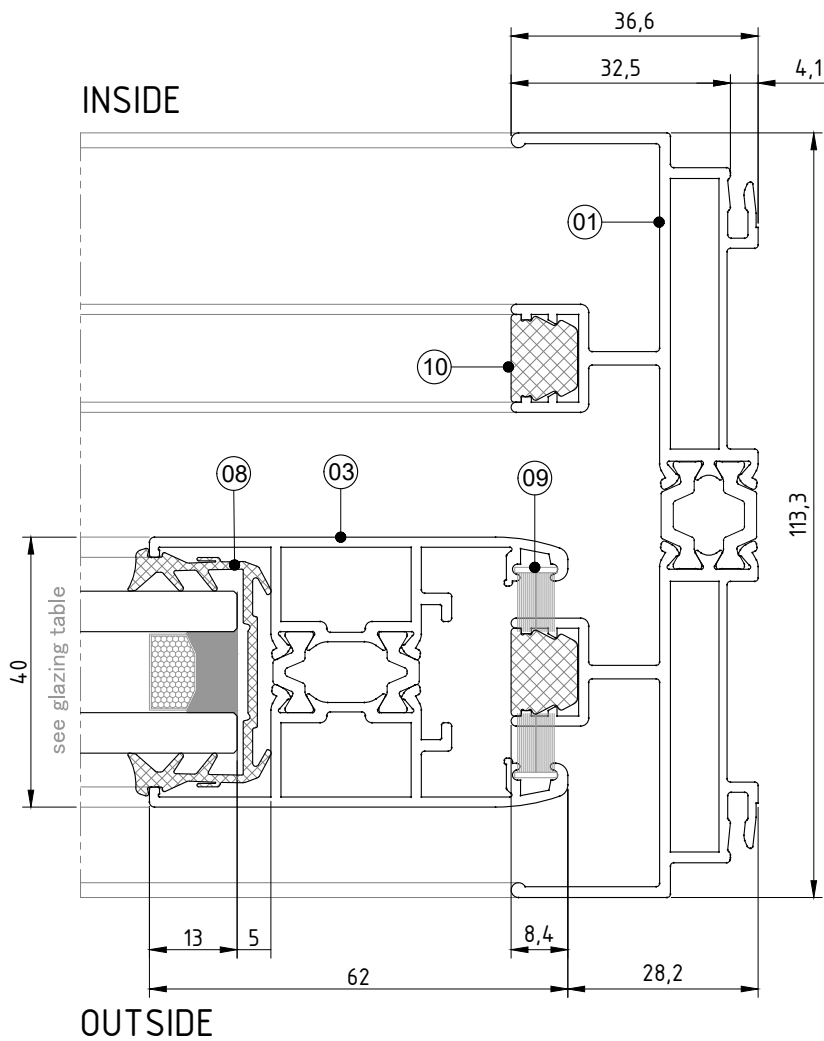

Sections / Details

*** optional item

⊛ for high performance use bulb gasket (Z 913154) instead of brush

12/2022

Door - Meeting style horizontal section

- ① Frame B 061300
- ② Sash B 061304
- ③ Sash B 061303
- ④ Sash P 061108***
- ⑤ Mid profile P 061115
- ⑥ Rail P 061140
- ⑦ Flymesh Sash P 660055
- ⑧ Glazing gasket Z 061808***
- ⑨ Woven pile Z 061812
- ⑩ Cover foam Z 060811
- ⑪ PVC Gasket Z 918565
- ⑫ Interlock gasket Z 061815
- ⑬ PVC interlock K 061001
- ⑭ Shaped plastic piece Z 061503
- ⑮ Distance piece Z 061508

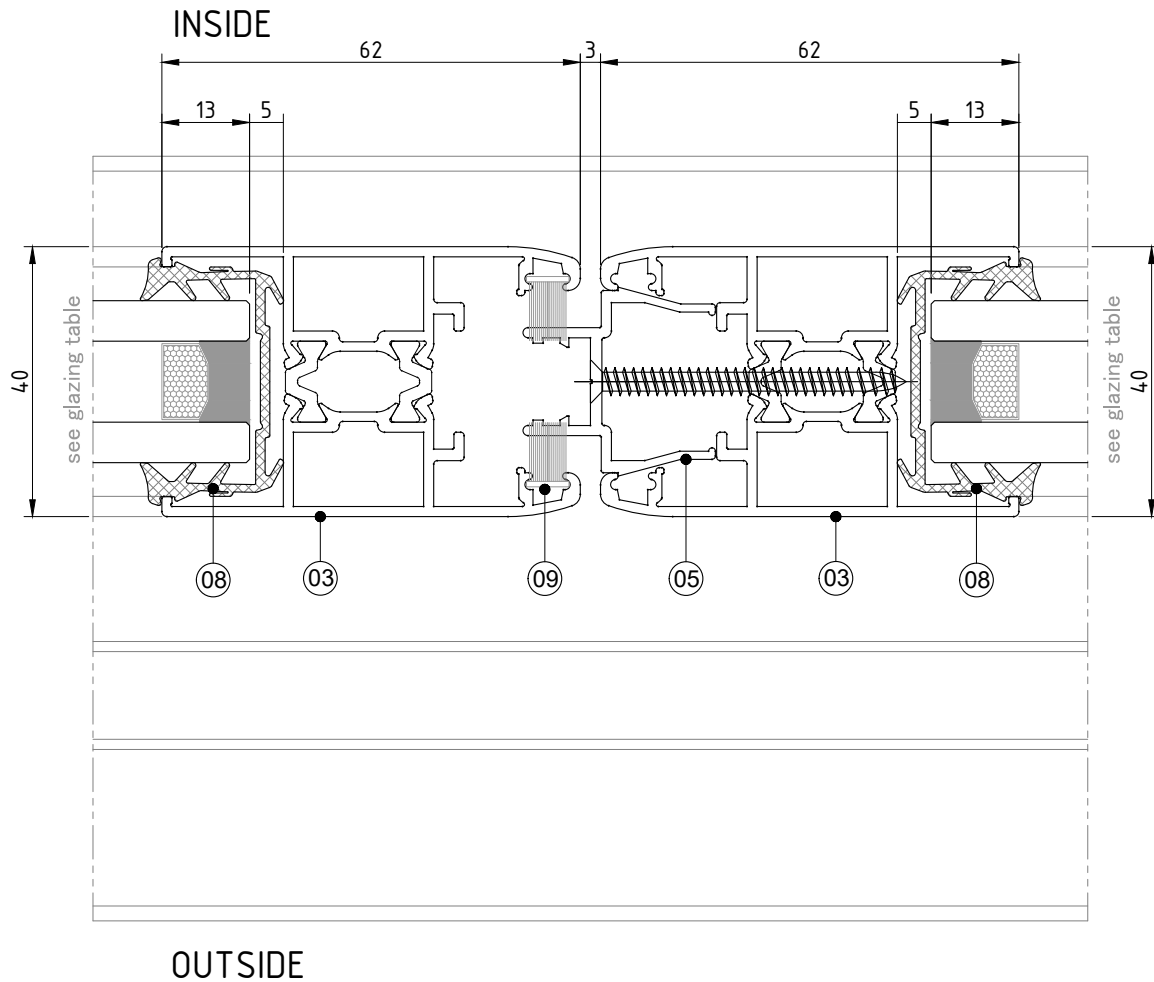
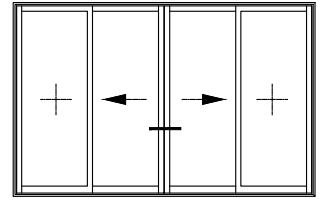

*** optional item
 ⊕ for high performance use bulb gasket (Z 913154) instead of brush

Door - Triple track vertical section

① Frame	B 061301	⑥ Rail	P 061140	⑪ PVC Gasket	Z 918565
② Sash	B 061304	⑦ Flymesh Sash	P 660055	⑫ Interlock gasket	Z 061815
③ Sash	B 061303	⑧ Glazing gasket	Z 061808***	⑬ PVC interlock	K 061001
④ Sash	P 061108***	⑨ Woven pile	Z 061812	⑭ Shaped plastic piece	Z 061503
⑤ Mid profile	P 061115	⑩ Cover foam	Z 060811	⑮ Distance piece	Z 061508

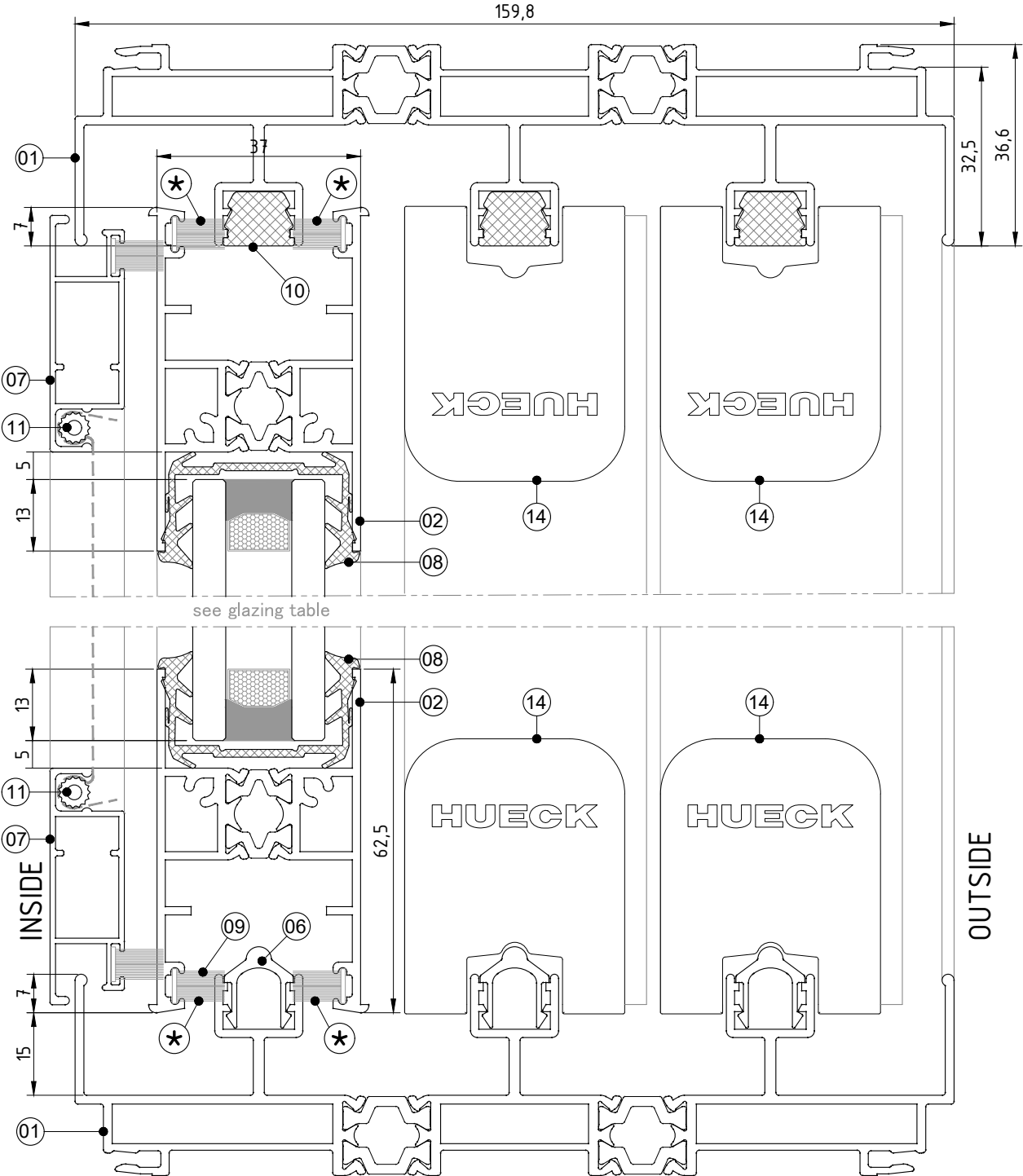
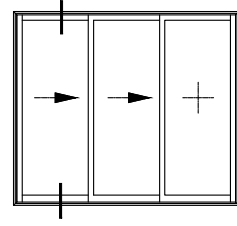

see glazing table

*** optional item
 * for high performance use bulb gasket (Z 913154) instead of brush

Door - Triple track vertical section

① Frame	B 061301	⑥ Rail	P 061140	⑪ PVC Gasket	Z 918565
② Sash	B 061304	⑦ Flymesh Sash	P 660055	⑫ Interlock gasket	Z 061815
③ Sash	B 061303	⑧ Glazing gasket	Z 061808***	⑬ PVC interlock	K 061001
④ Sash	P 061108***	⑨ Woven pile	Z 061812	⑭ Shaped plastic piece	Z 061503
⑤ Mid profile	P 061115	⑩ Cover foam	Z 060811	⑮ Distance piece	Z 061508

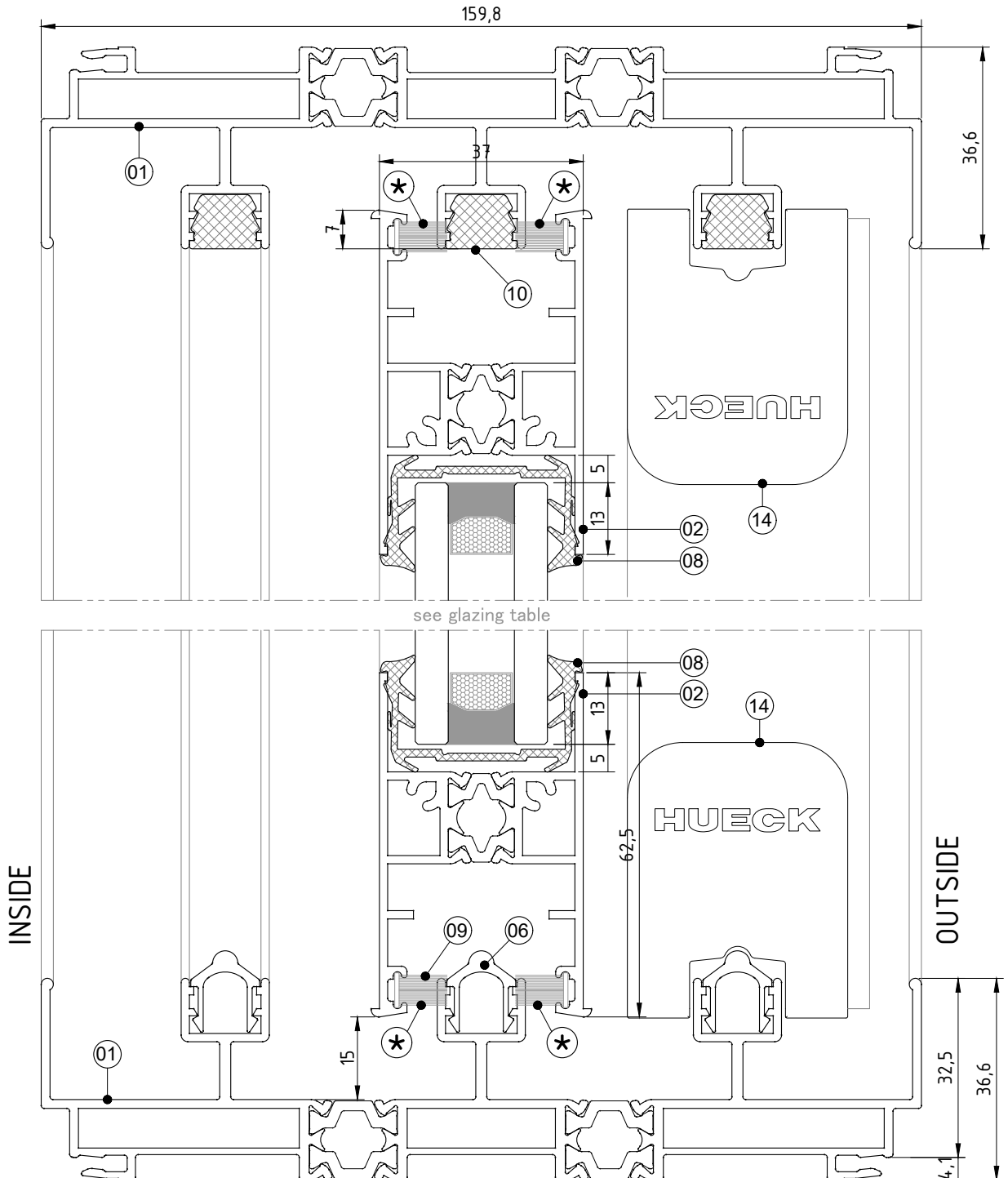
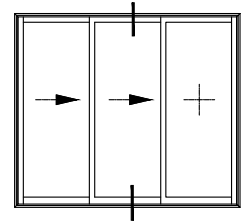

*** optional item
 ⊕ for high performance use bulb gasket (Z 913154) instead of brush

Door - Triple track vertical section

① Frame	B 061301	⑥ Rail	P 061140	⑪ PVC Gasket	Z 918565
② Sash	B 061304	⑦ Flymesh Sash	P 660055	⑫ Interlock gasket	Z 061815
③ Sash	B 061303	⑧ Glazing gasket	Z 061808***	⑬ PVC interlock	K 061001
④ Sash	P 061108***	⑨ Woven pile	Z 061812	⑭ Shaped plastic piece	Z 061503
⑤ Mid profile	P 061115	⑩ Cover foam	Z 060811	⑮ Distance piece	Z 061508

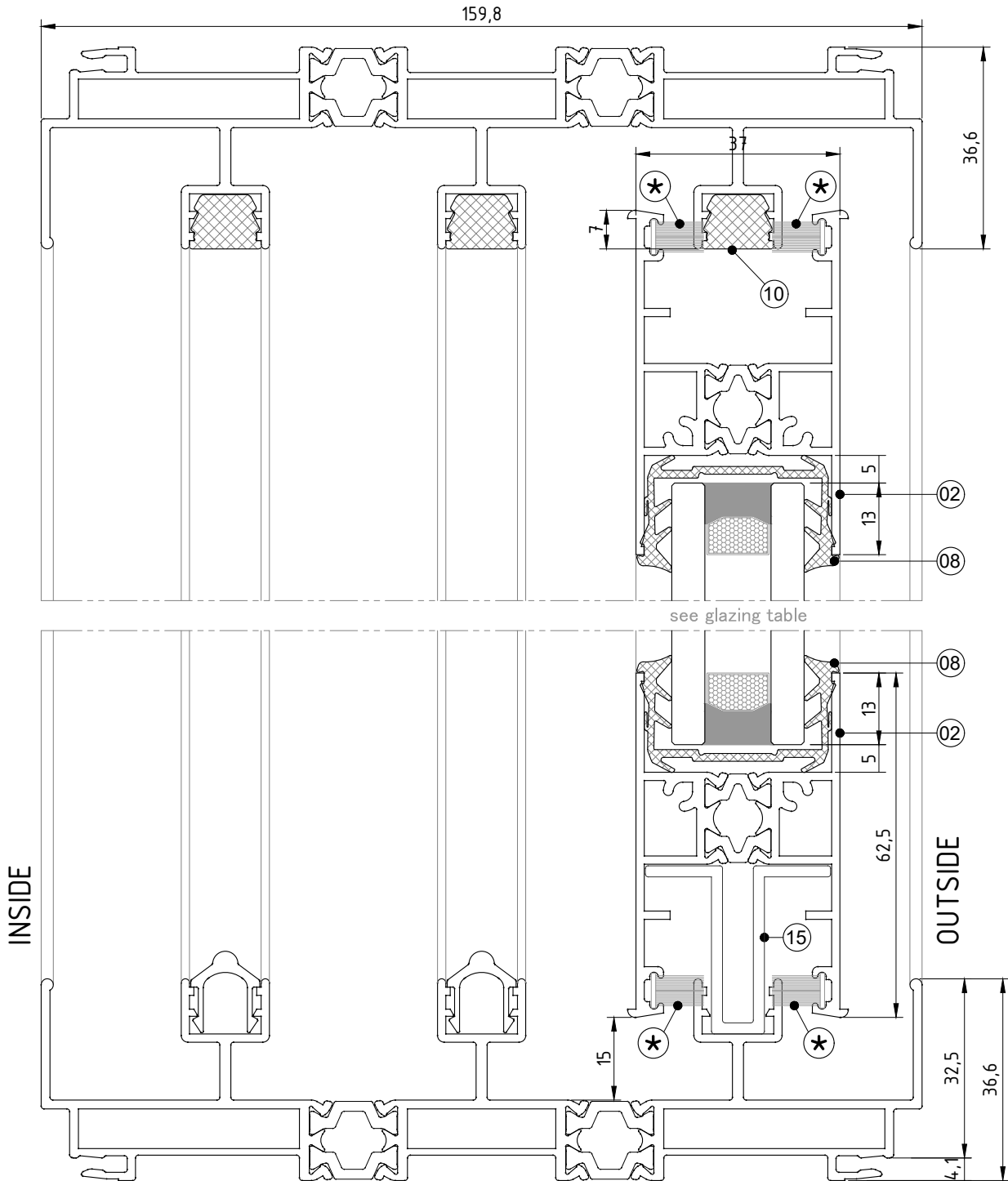
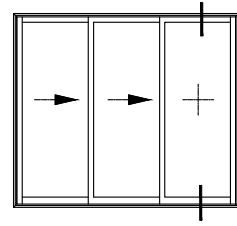

*** optional item
 ⊛ for high performance use bulb gasket (Z 913154) instead of brush

Sections / Details

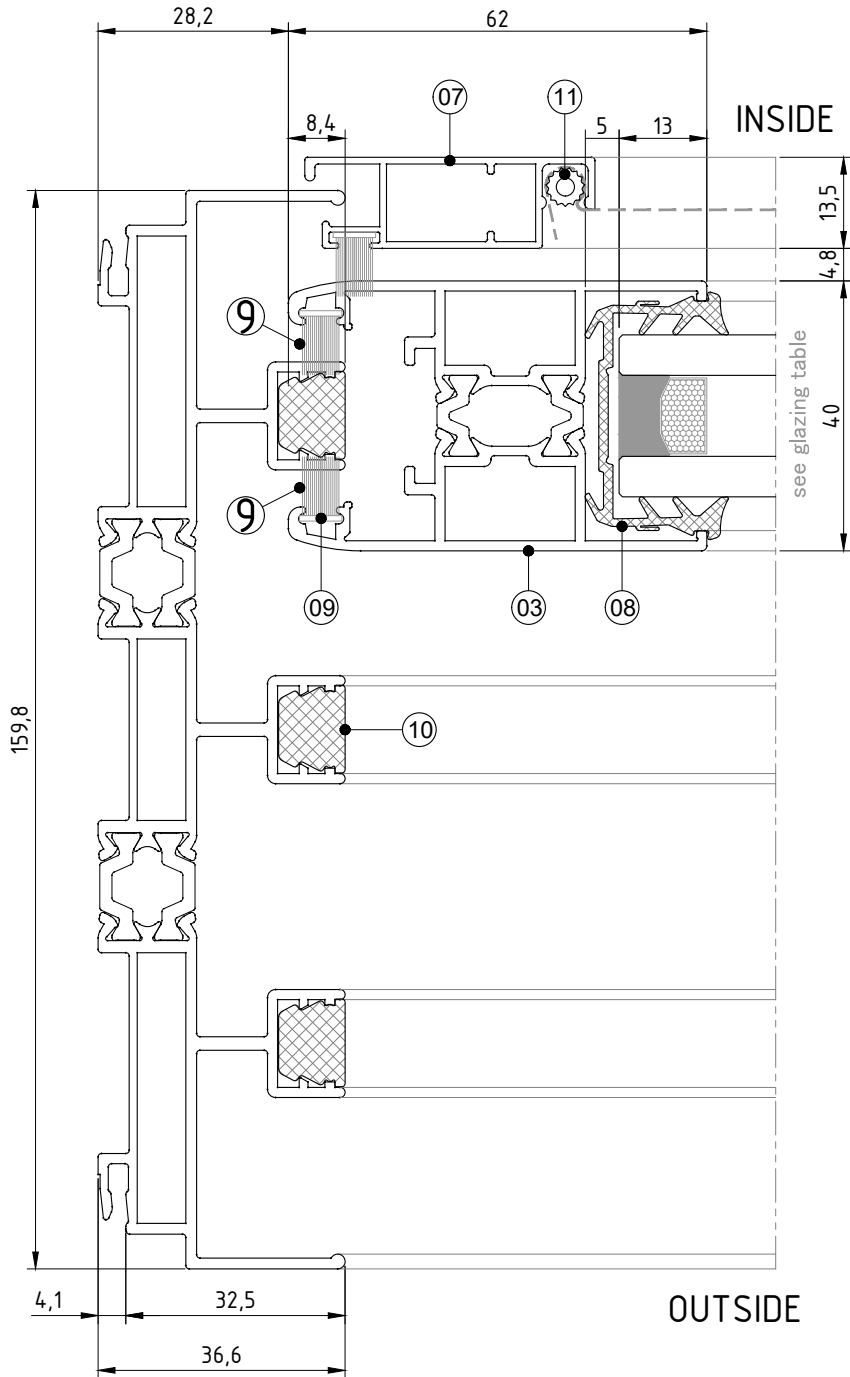
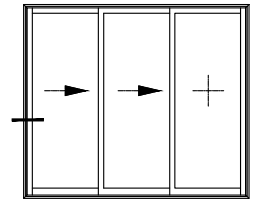

- | | | |
|---|----------------------|-------------|
| ① | Frame | B 061301 |
| ② | Sash | B 061304 |
| ③ | Sash | B 061303 |
| ④ | Sash | P 061108*** |
| ⑤ | Mid profile | P 061115 |
| ⑥ | Rail | P 061140 |
| ⑦ | Flymesh Sash | P 660055 |
| ⑧ | Glazing gasket | Z 061808*** |
| ⑨ | Woven pile | Z 061812 |
| ⑩ | Cover foam | Z 060811 |
| ⑪ | PVC Gasket | Z 918565 |
| ⑫ | Interlock gasket | Z 061815 |
| ⑬ | PVC interlock | K 061001 |
| ⑭ | Shaped plastic piece | Z 061503 |
| ⑮ | Distance piece | Z 061508 |

*** optional item

⊕ for high performance use bulb gasket (Z 913154) instead of brush

12/2022

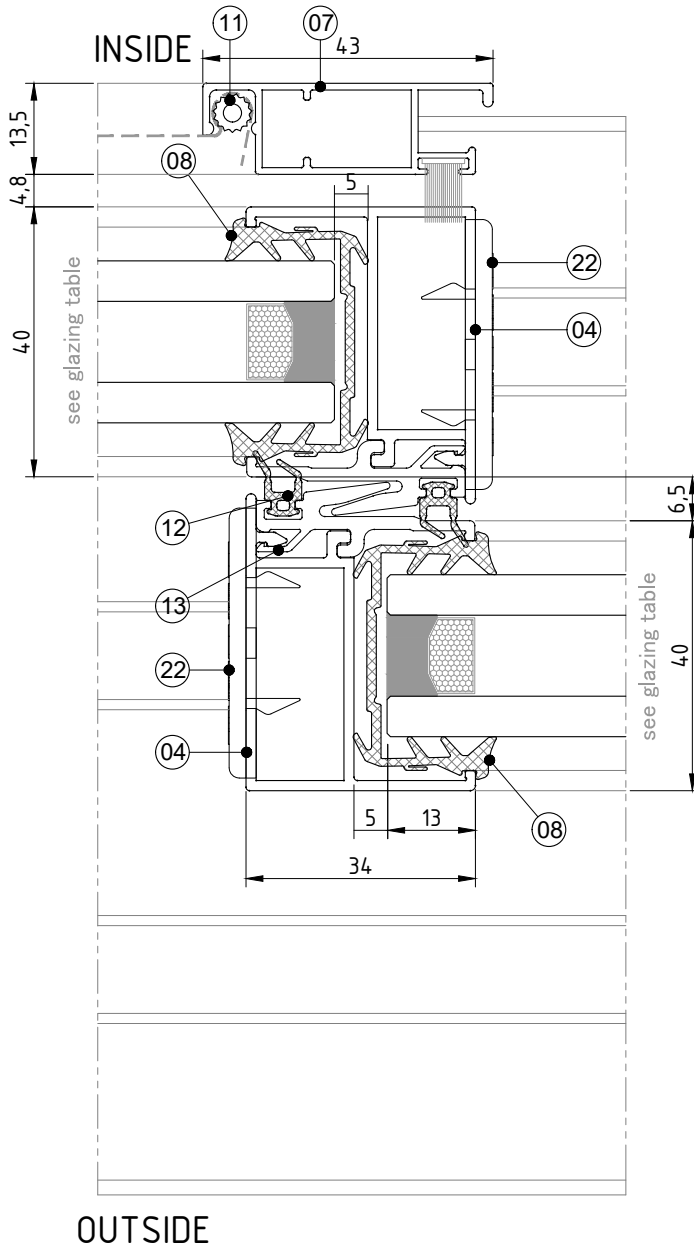
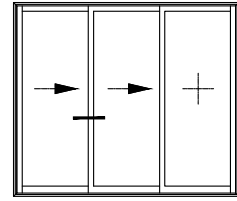

①	Frame	B 061301
②	Sash	B 061304
③	Sash	B 061303
④	Sash	P 061108***
⑤	Mid profile	P 061115
⑥	Rail	P 061140
⑦	Flymesh Sash	P 660055
⑧	Glazing gasket	Z 061808***
⑨	Woven pile	Z 061812
⑩	Cover foam	Z 060811
⑪	PVC Gasket	Z 918565
⑫	Interlock gasket	Z 061815
⑬	PVC interlock	K 061001
⑭	Shaped plastic piece	Z 061503
⑮	Distance piece	Z 061508

Sections / Details

*** optional item

⊛ for high performance use bulb gasket (Z 913154) instead of brush

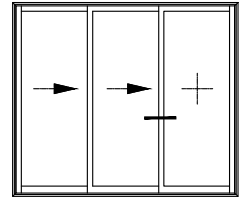

INSIDE

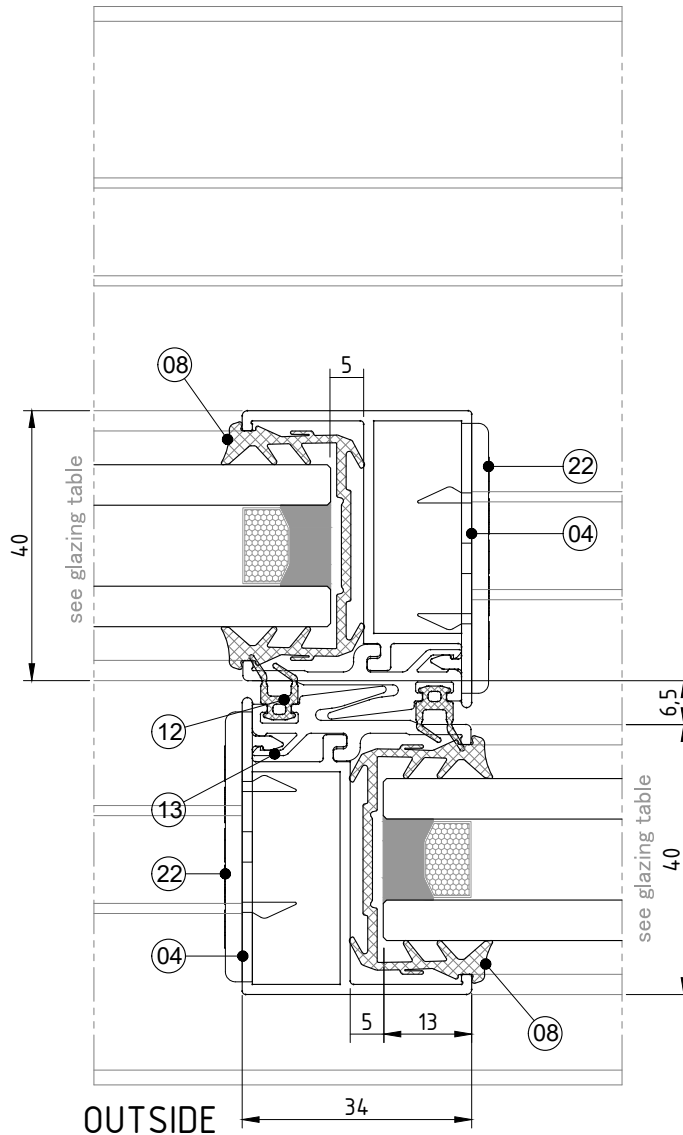

- | | | |
|---|----------------------|-------------|
| ① | Frame | B 061301 |
| ② | Sash | B 061304 |
| ③ | Sash | B 061303 |
| ④ | Sash | P 061108*** |
| ⑤ | Mid profile | P 061115 |
| ⑥ | Rail | P 061140 |
| ⑦ | Flymesh Sash | P 660055 |
| ⑧ | Glazing gasket | Z 061808*** |
| ⑨ | Woven pile | Z 061812 |
| ⑩ | Cover foam | Z 060811 |
| ⑪ | PVC Gasket | Z 918565 |
| ⑫ | Interlock gasket | Z 061815 |
| ⑬ | PVC interlock | K 061001 |
| ⑭ | Shaped plastic piece | Z 061503 |
| ⑮ | Distance piece | Z 061508 |

OUTSIDE

*** optional item

⊕ for high performance use bulb gasket (Z 913154) instead of brush

12/2022

Door - Triple track horizontal section

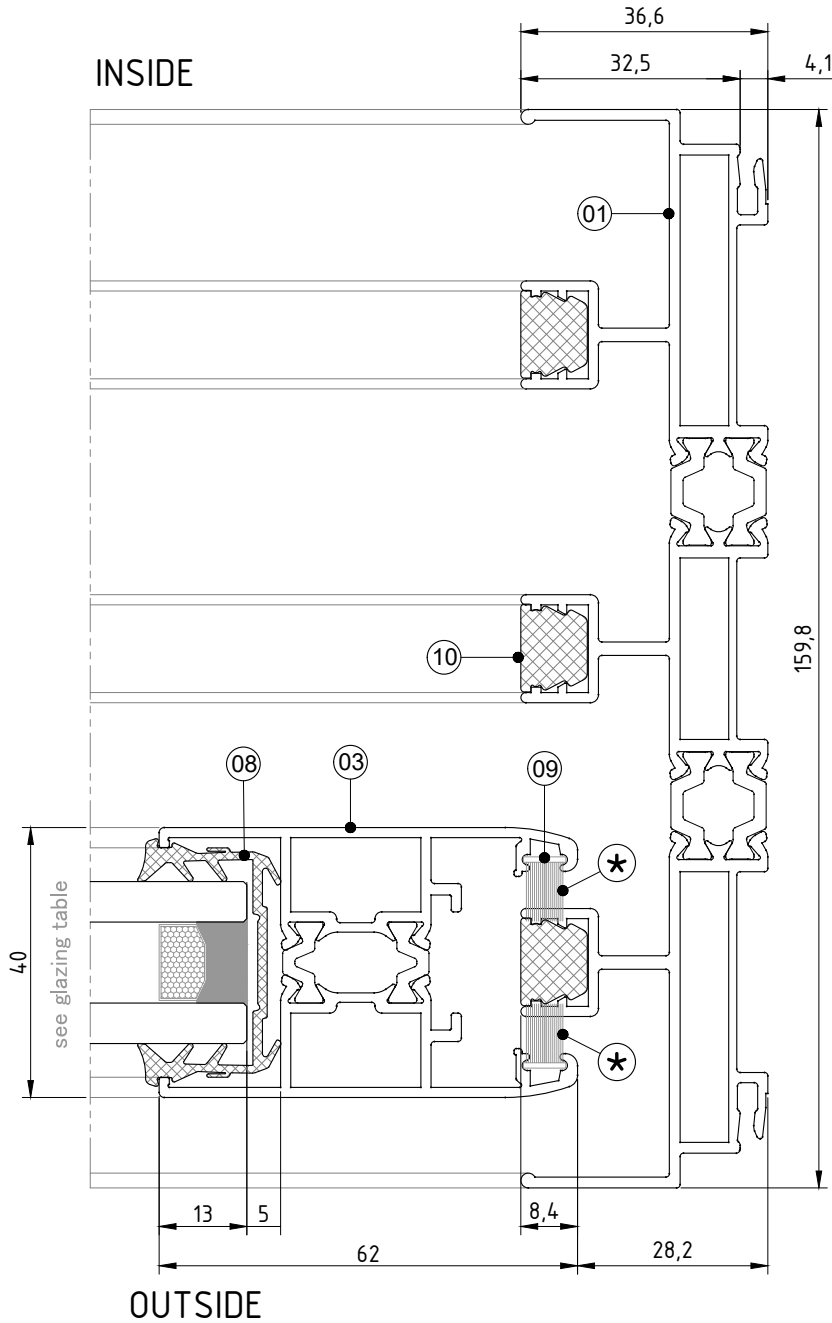
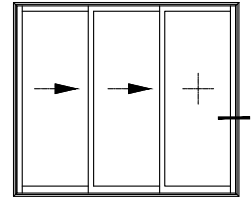

- | | | |
|---|----------------------|-------------|
| ① | Frame | B 061301 |
| ② | Sash | B 061304 |
| ③ | Sash | B 061303 |
| ④ | Sash | P 061108*** |
| ⑤ | Mid profile | P 061115 |
| ⑥ | Rail | P 061140 |
| ⑦ | Flymesh Sash | P 660055 |
| ⑧ | Glazing gasket | Z 061808*** |
| ⑨ | Woven pile | Z 061812 |
| ⑩ | Cover foam | Z 060811 |
| ⑪ | PVC Gasket | Z 918565 |
| ⑫ | Interlock gasket | Z 061815 |
| ⑬ | PVC interlock | K 061001 |
| ⑭ | Shaped plastic piece | Z 061503 |
| ⑮ | Distance piece | Z 061508 |

*** optional item

⊛ for high performance use bulb gasket (Z 913154) instead of brush

12/2022

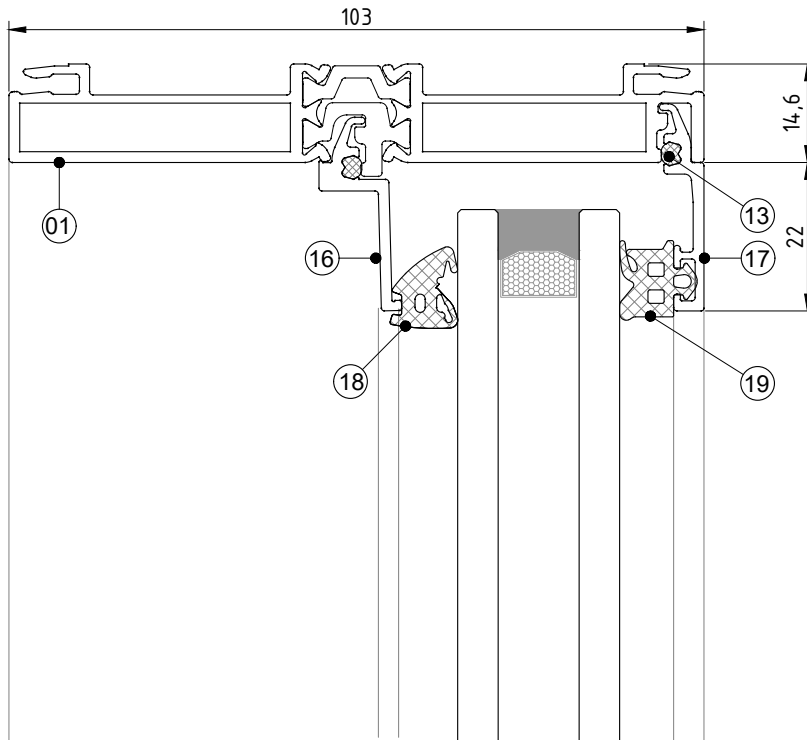
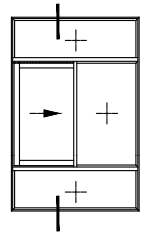

- | | | |
|---|----------------------|-------------|
| ① | Frame | B 061309 |
| ② | Sash | B 061304 |
| ③ | Sash | B 061303 |
| ④ | Sash | P 061108*** |
| ⑤ | Sash | P 061109*** |
| ⑥ | Rail | P 061112 |
| ⑦ | Top Barrier | P 061136 |
| ⑧ | Flymesh Sash | P 660055 |
| ⑨ | Glazing gasket | Z 061808*** |
| ⑩ | Groove Gasket | Z 061807 |
| ⑪ | Cover Gasket | Z 061806 |
| ⑫ | Woven pile | Z 061812 |
| ⑬ | Gasket cord | Z 902161 |
| ⑭ | Cover foam | Z 060811 |
| ⑮ | PVC Gasket | Z 918565 |
| ⑯ | Beading in | Z 061122 |
| ⑰ | Beading out | Z 061123 |
| ⑱ | Glazing gasket in | Z 914261*** |
| ⑲ | Glazing gasket out | Z 912612*** |
| ⑳ | Interlock gasket | Z 061815 |
| ㉑ | PVC interlock | K 061001 |
| ㉒ | Shaped plastic piece | Z 061503 |
| ㉓ | Mid transom | B 061311 |

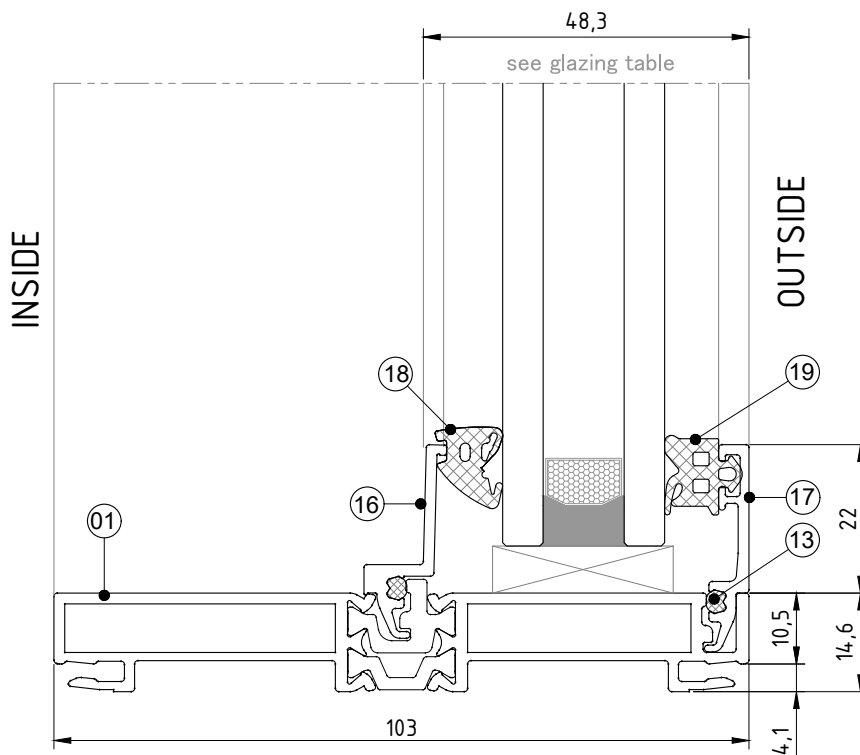

*** optional item

⊕ for high performance use bulb gasket (Z 913154) instead of brush



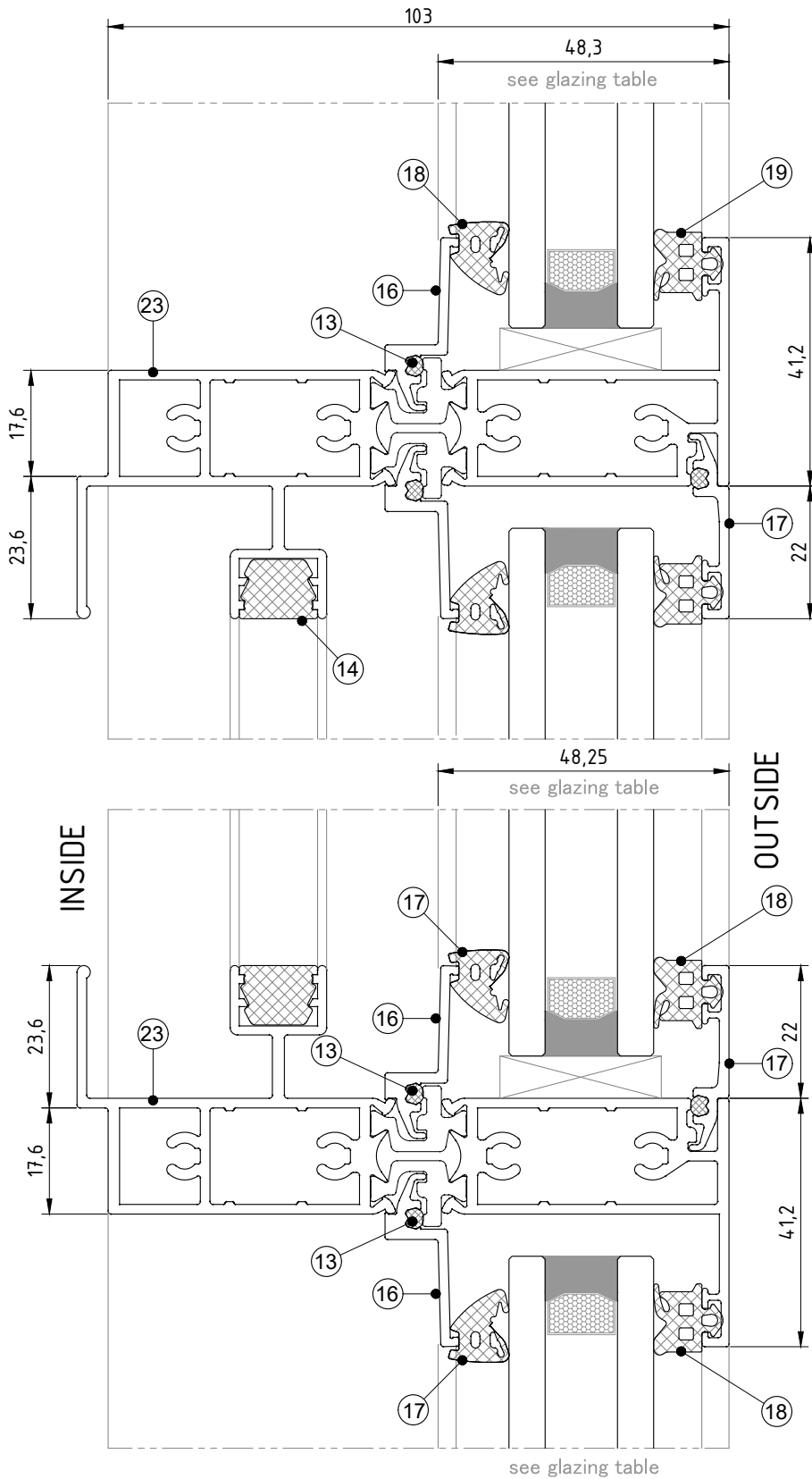

- | | | |
|---|----------------------|-------------|
| ① | Frame | B 061309 |
| ② | Sash | B 061304 |
| ③ | Sash | B 061303 |
| ④ | Sash | P 061108*** |
| ⑤ | Sash | P 061109*** |
| ⑥ | Rail | P 061112 |
| ⑦ | Top Barrier | P 061136 |
| ⑧ | Flymesh Sash | P 660055 |
| ⑨ | Glazing gasket | Z 061808*** |
| ⑩ | Groove Gasket | Z 061807 |
| ⑪ | Cover Gasket | Z 061806 |
| ⑫ | Woven pile | Z 061812 |
| ⑬ | Gasket cord | Z 902161 |
| ⑭ | Cover foam | Z 060811 |
| ⑮ | PVC Gasket | Z 918565 |
| ⑯ | Beading in | Z 061122 |
| ⑰ | Beading out | Z 061123 |
| ⑱ | Glazing gasket in | Z 914261*** |
| ⑲ | Glazing gasket out | Z 912612*** |
| ⑳ | Interlock gasket | Z 061815 |
| ㉑ | PVC interlock | K 061001 |
| ㉒ | Shaped plastic piece | Z 061503 |
| ㉓ | Mid transom | B 061311 |

*** optional item

⊗ for high performance use bulb gasket (Z 913154) instead of brush

12/2022

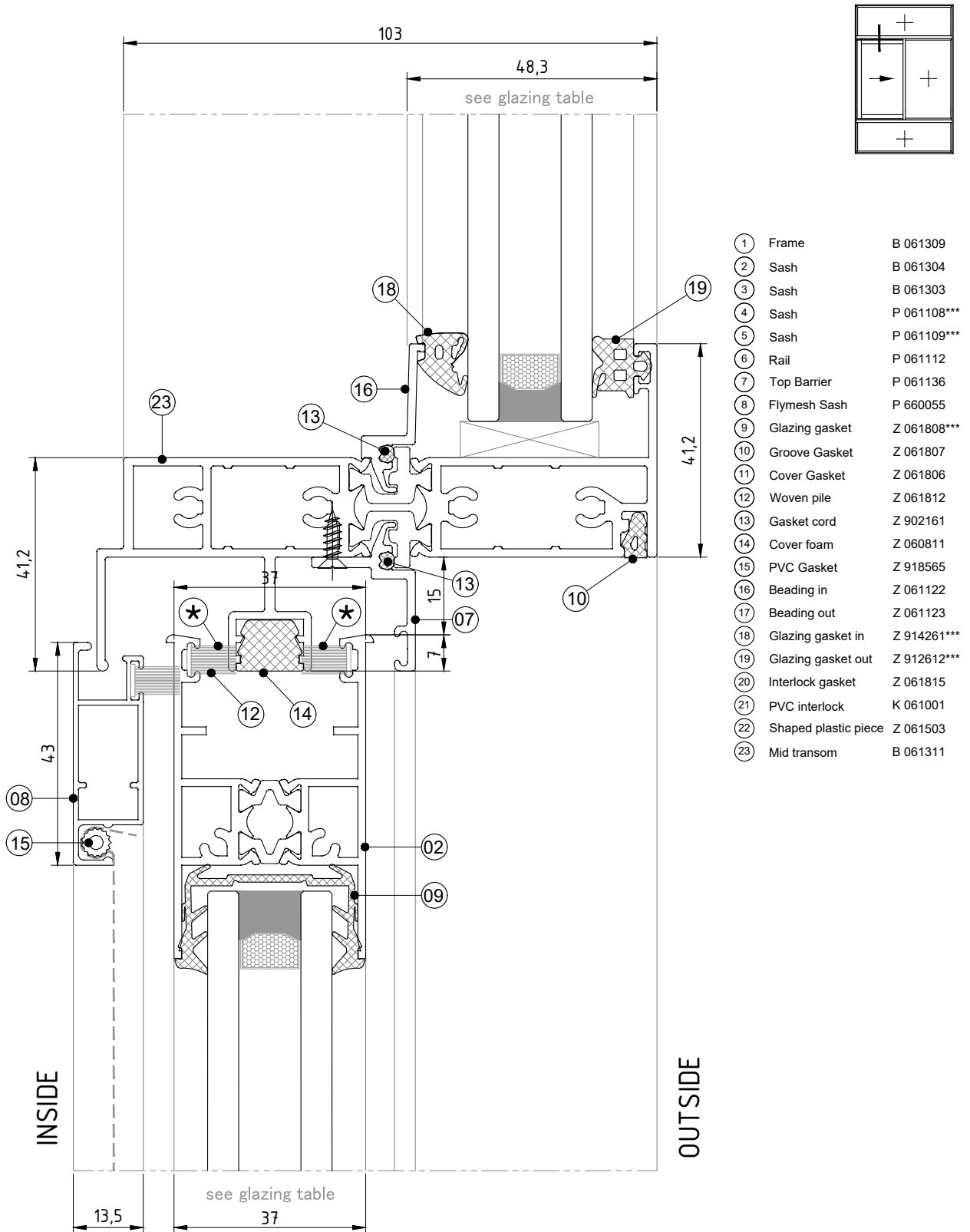

*** optional item

⊕ for high performance use bulb gasket (Z 913154) instead of brush



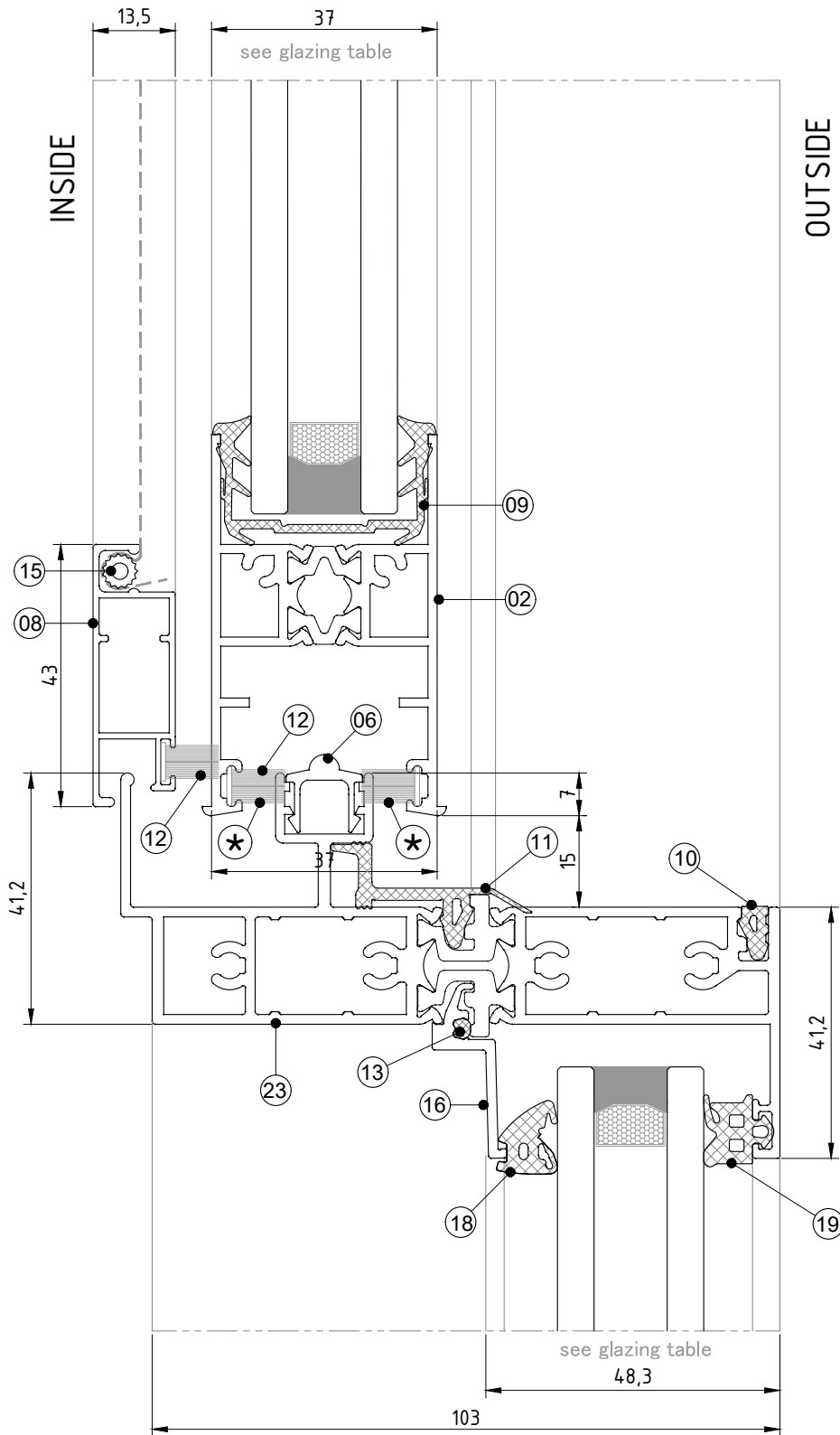
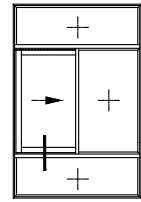

- | | | |
|---|----------------------|-------------|
| ① | Frame | B 061309 |
| ② | Sash | B 061304 |
| ③ | Sash | B 061303 |
| ④ | Sash | P 061108*** |
| ⑤ | Sash | P 061109*** |
| ⑥ | Rail | P 061112 |
| ⑦ | Top Barrier | P 061136 |
| ⑧ | Flymesh Sash | P 660055 |
| ⑨ | Glazing gasket | Z 061808*** |
| ⑩ | Groove Gasket | Z 061807 |
| ⑪ | Cover Gasket | Z 061806 |
| ⑫ | Woven pile | Z 061812 |
| ⑬ | Gasket cord | Z 902161 |
| ⑭ | Cover foam | Z 060811 |
| ⑮ | PVC Gasket | Z 918565 |
| ⑯ | Beading in | Z 061122 |
| ⑰ | Beading out | Z 061123 |
| ⑱ | Glazing gasket in | Z 914261*** |
| ⑲ | Glazing gasket out | Z 912612*** |
| ⑳ | Interlock gasket | Z 061815 |
| ㉑ | PVC interlock | K 061001 |
| ㉒ | Shaped plastic piece | Z 061503 |
| ㉓ | Mid transom | B 061311 |

*** optional item

⊛ for high performance use bulb gasket (Z 913154) instead of brush

Sections / Details

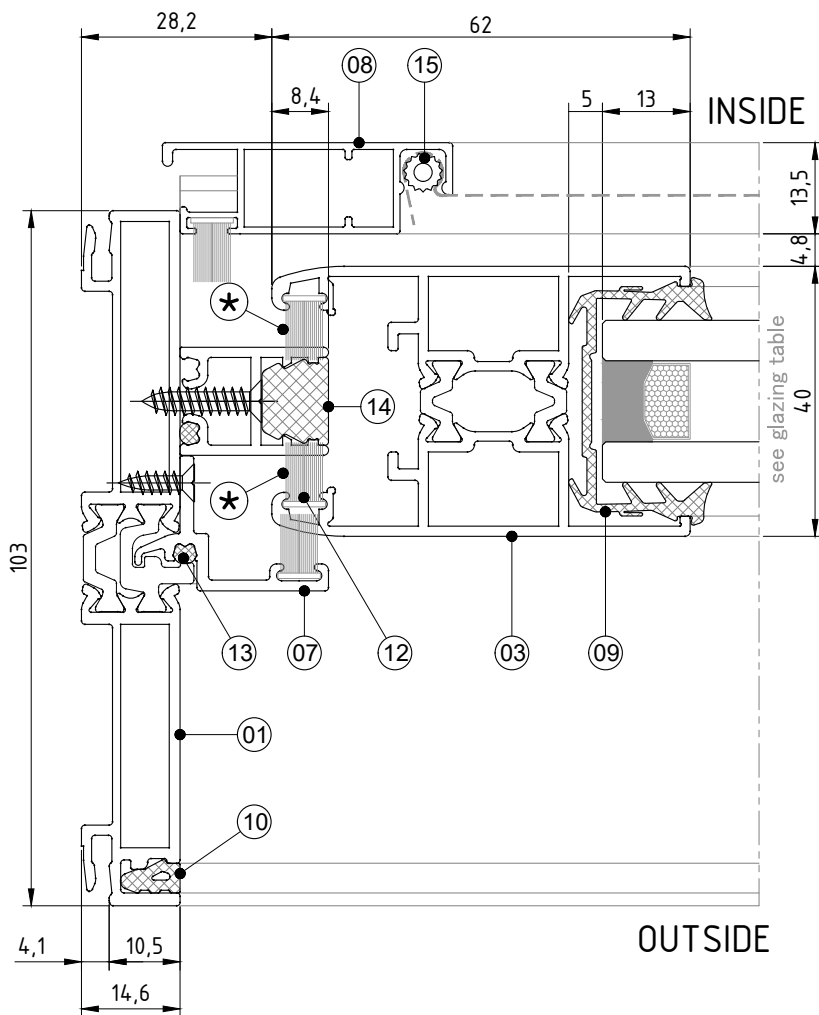
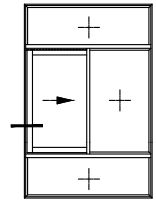

①	Frame	B 061309
②	Sash	B 061304
③	Sash	B 061303
④	Sash	P 061108***
⑤	Sash	P 061109***
⑥	Rail	P 061112
⑦	Top Barrier	P 061136
⑧	Flymesh Sash	P 660055
⑨	Glazing gasket	Z 061808***
⑩	Groove Gasket	Z 061807
⑪	Cover Gasket	Z 061806
⑫	Woven pile	Z 061812
⑬	Gasket cord	Z 902161
⑭	Cover foam	Z 060811
⑮	PVC Gasket	Z 918565
⑯	Beading in	Z 061122
⑰	Beading out	Z 061123
⑱	Glazing gasket in	Z 914261***
⑲	Glazing gasket out	Z 912612***
⑳	Interlock gasket	Z 061815
㉑	PVC interlock	K 061001
㉒	Shaped plastic piece	Z 061503
㉓	Mid transom	B 061311

*** optional item

⊕ for high performance use bulb gasket (Z 913154) instead of brush

12/2022

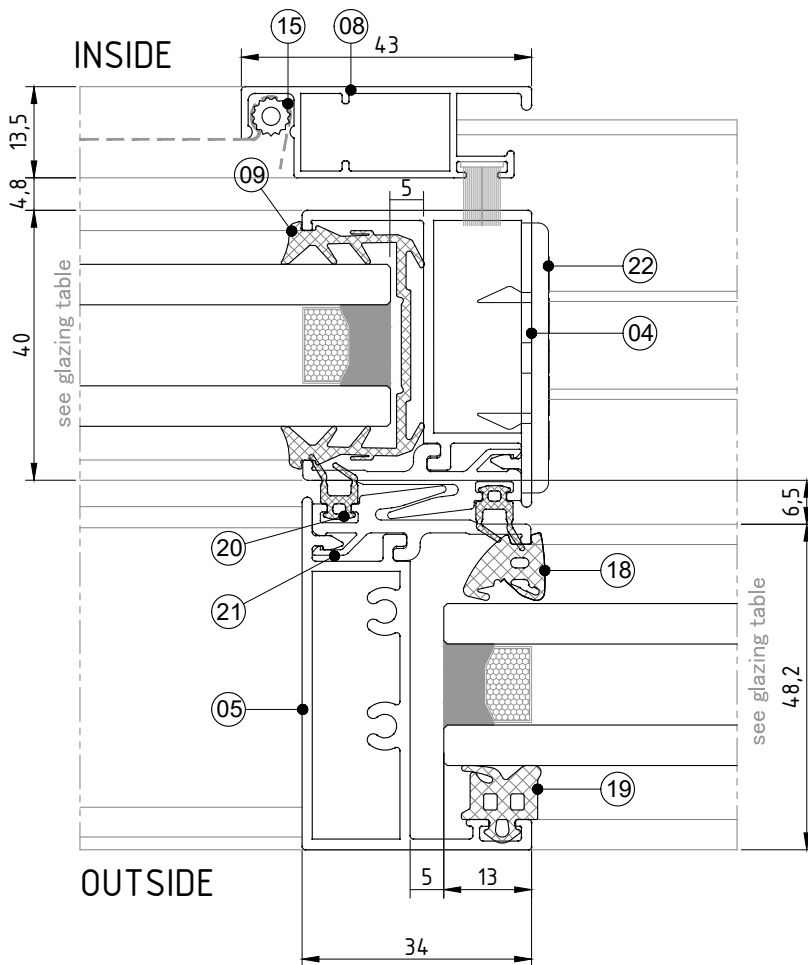
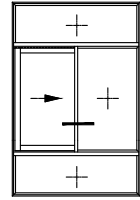

①	Frame	B 061309
②	Sash	B 061304
③	Sash	B 061303
④	Sash	P 061108***
⑤	Sash	P 061109***
⑥	Rail	P 061112
⑦	Top Barrier	P 061136
⑧	Flymesh Sash	P 660055
⑨	Glazing gasket	Z 061808***
⑩	Groove Gasket	Z 061807
⑪	Cover Gasket	Z 061806
⑫	Woven pile	Z 663032***
⑬	Gasket cord	Z 902161
⑭	Cover foam	Z 060811
⑮	PVC Gasket	Z 918565
⑯	Beading in	Z 061122
⑰	Beading out	Z 061123
⑱	Glazing gasket in	Z 914261***
⑲	Glazing gasket out	Z 912612***
⑳	Interlock gasket	Z 061815
㉑	PVC interlock	K 061001
㉒	Shaped plastic piece	Z 061503
㉓	Mid transom	B 061311

*** optional item

⊛ for high performance use bulb gasket (Z 913154) instead of brush

12/2022

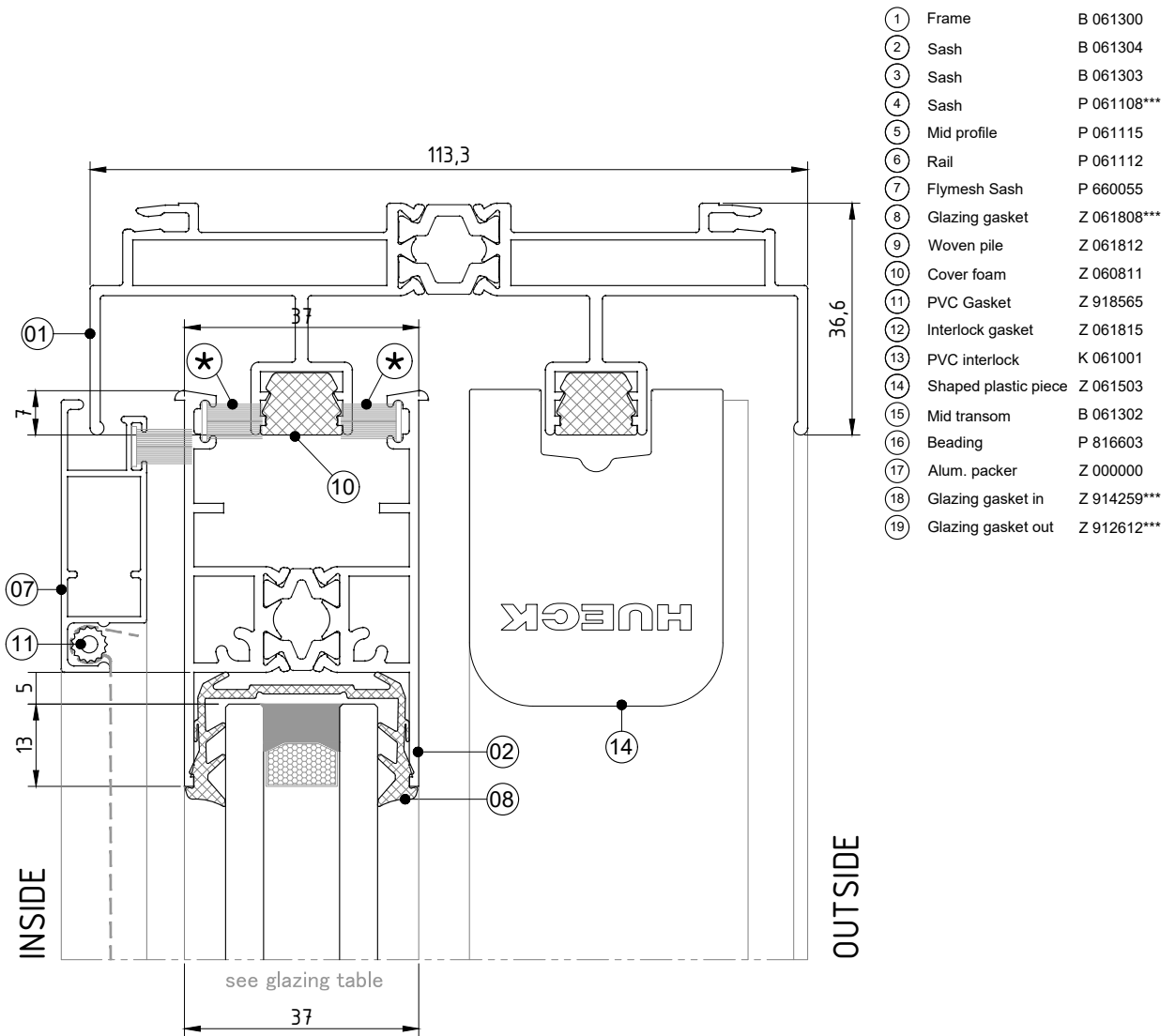
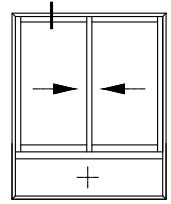

- | | | |
|---|----------------------|-------------|
| ① | Frame | B 061300 |
| ② | Sash | B 061304 |
| ③ | Sash | B 061303 |
| ④ | Sash | P 061108*** |
| ⑤ | Mid profile | P 061115 |
| ⑥ | Rail | P 061112 |
| ⑦ | Flymesh Sash | P 660055 |
| ⑧ | Glazing gasket | Z 061808*** |
| ⑨ | Woven pile | Z 061812 |
| ⑩ | Cover foam | Z 060811 |
| ⑪ | PVC Gasket | Z 918565 |
| ⑫ | Interlock gasket | Z 061815 |
| ⑬ | PVC interlock | K 061001 |
| ⑭ | Shaped plastic piece | Z 061503 |
| ⑮ | Mid transom | B 061302 |
| ⑯ | Beading | P 816603 |
| ⑰ | Alum. packer | Z 000000 |
| ⑱ | Glazing gasket in | Z 914259*** |
| ⑲ | Glazing gasket out | Z 912612*** |

*** optional item

⊕ for high performance use bulb gasket (Z 913154) instead of brush



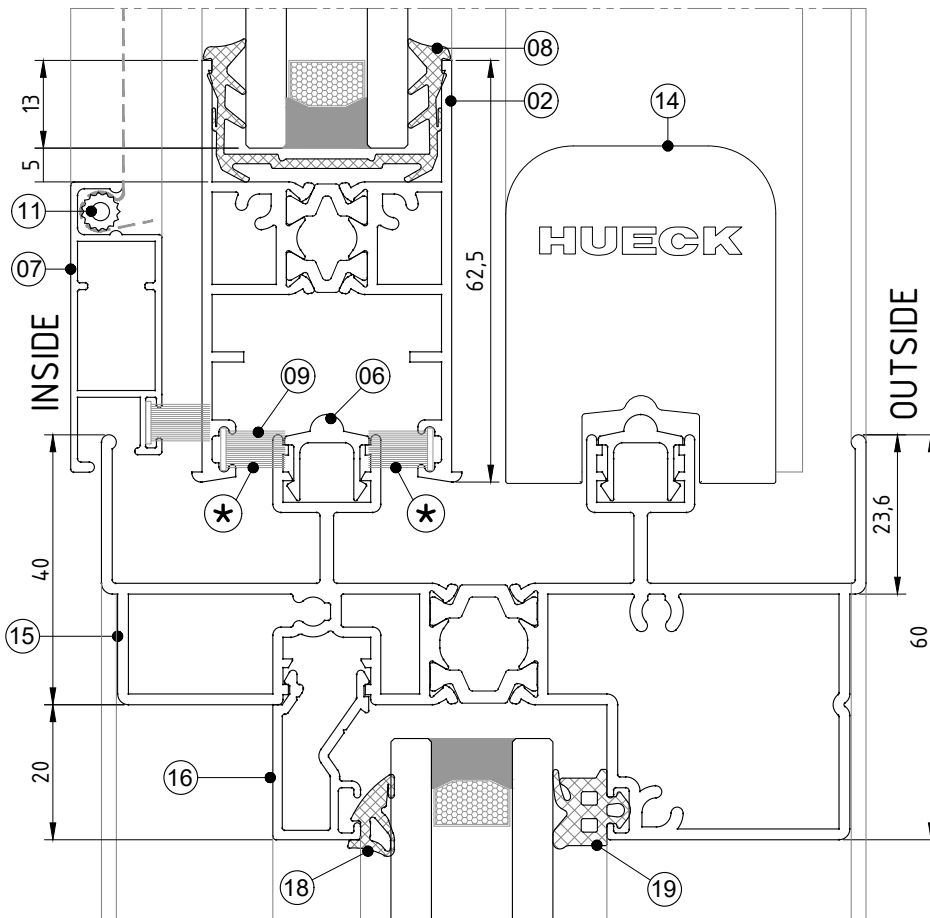
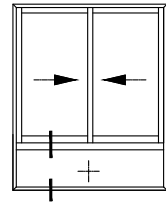

①	Frame	B 061300
②	Sash	B 061304
③	Sash	B 061303
④	Sash	P 061108***
⑤	Mid profile	P 061115
⑥	Rail	P 061112
⑦	Flymesh Sash	P 660055
⑧	Glazing gasket	Z 061808***
⑨	Woven pile	Z 061812
⑩	Cover foam	Z 060811
⑪	PVC Gasket	Z 918565
⑫	Interlock gasket	Z 061815
⑬	PVC interlock	K 061001
⑭	Shaped plastic piece	Z 061503
⑮	Mid transom	B 061302
⑯	Beading	P 816603
⑰	Alum. packer	Z 000000
⑱	Glazing gasket in	Z 914259***
⑲	Glazing gasket out	Z 912612***

see glazing table

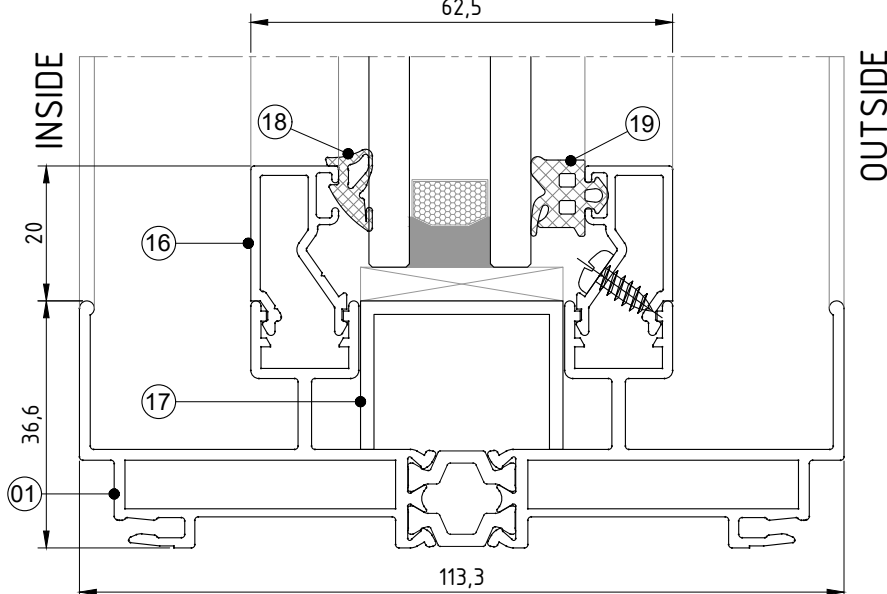

*** optional item

* for high performance use bulb gasket (Z 913154) instead of brush

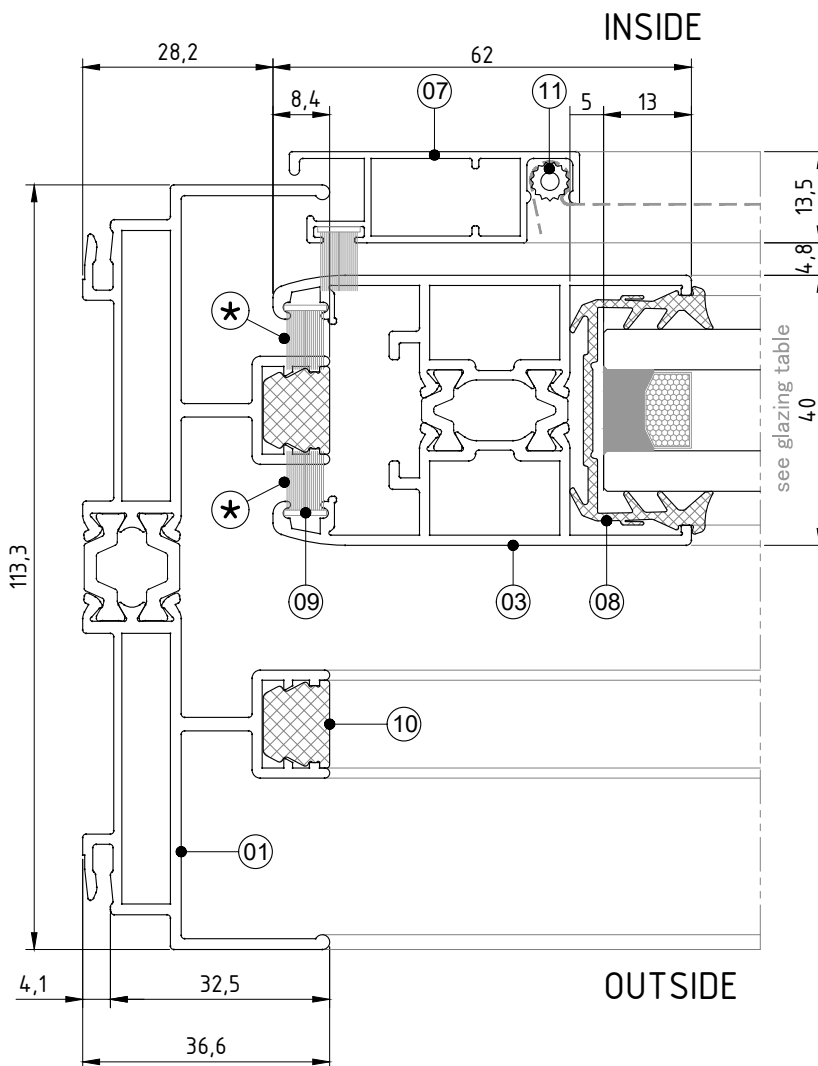
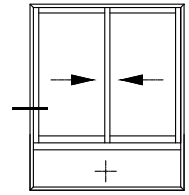

①	Frame	B 061300
②	Sash	B 061304
③	Sash	B 061303
④	Sash	P 061108***
⑤	Mid profile	P 061115
⑥	Rail	P 061112
⑦	Flymesh Sash	P 660055
⑧	Glazing gasket	Z 061808***
⑨	Woven pile	Z 663032***
⑩	Cover foam	Z 060811
⑪	PVC Gasket	Z 918565
⑫	Interlock gasket	Z 061815
⑬	PVC interlock	K 061001
⑭	Shaped plastic piece	Z 061503
⑮	Mid transom	B 061302
⑯	Beading	P 816603
⑰	Alum. packer	Z 000000
⑱	Glazing gasket in	Z 914259***
⑲	Glazing gasket out	Z 912612***

*** optional item

⊕ for high performance use bulb gasket (Z 913154) instead of brush

12/2022



Volato

E27

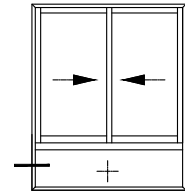

Sections / Details

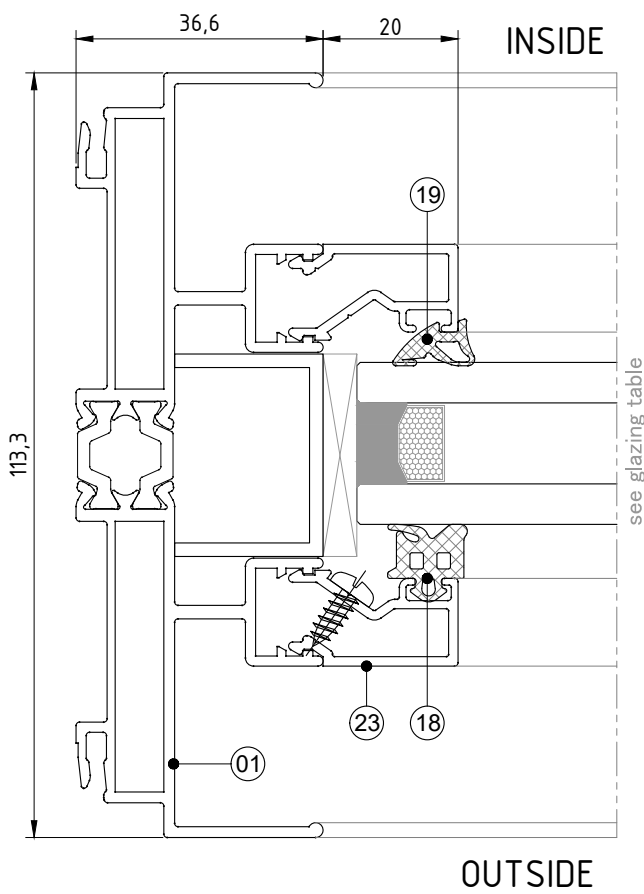

①	Frame	B 061300
②	Sash	B 061304
③	Sash	B 061303
④	Sash	P 061108***
⑤	Mid profile	P 061115
⑥	Rail	P 061112
⑦	Flymesh Sash	P 660055
⑧	Glazing gasket	Z 061808***
⑨	Woven pile	Z 663032***
⑩	Cover foam	Z 060811
⑪	PVC Gasket	Z 918565
⑫	Interlock gasket	Z 061815
⑬	PVC interlock	K 061001
⑭	Shaped plastic piece	Z 061503
⑮	Mid transom	B 061302
⑯	Beading	P 816603
⑰	Alum. packer	Z 000000
⑱	Glazing gasket in	Z 914259***
⑲	Glazing gasket out	Z 912612***

*** optional item

⊛ for high performance use bulb gasket (Z 913154) instead of brush

12/2022

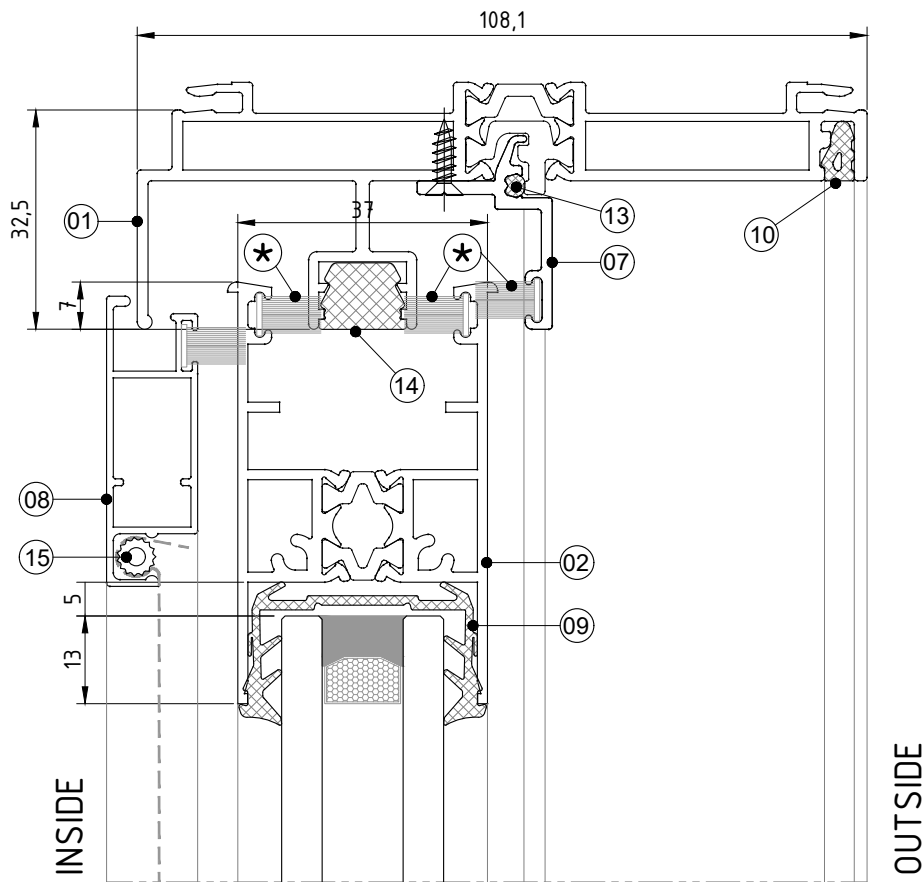
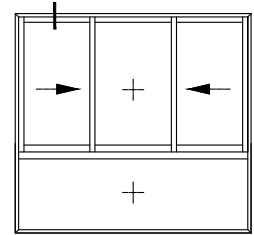

①	Frame	B 061300
②	Sash	B 061304
③	Sash	B 061303
④	Sash	P 061108***
⑤	Mid profile	P 061115
⑥	Rail	P 061112
⑦	Flymesh Sash	P 660055
⑧	Glazing gasket	Z 061808***
⑨	Woven pile	Z 663032***
⑩	Cover foam	Z 060811
⑪	PVC Gasket	Z 918565
⑫	Interlock gasket	Z 061815
⑬	PVC interlock	K 061001
⑭	Shaped plastic piece	Z 061503
⑮	Mid transom	B 061302
⑯	Beading	P 816603
⑰	Alum. packer	Z 000000
⑱	Glazing gasket in	Z 914259***
⑲	Glazing gasket out	Z 912612***

*** optional item

⊕ for high performance use bulb gasket (Z 913154) instead of brush



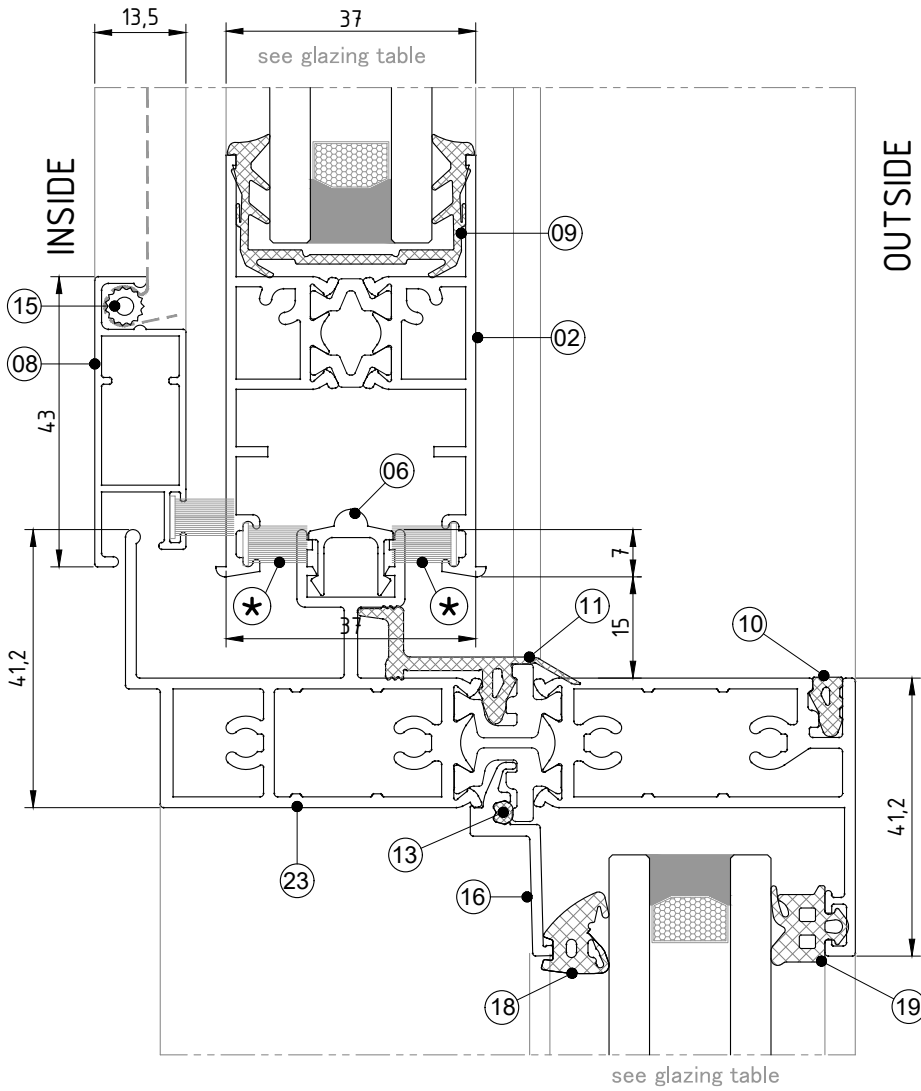

- | | | |
|---|----------------------|-------------|
| ① | Frame | B 061300 |
| ② | Sash | B 061304 |
| ③ | Sash | B 061303 |
| ④ | Sash | P 061108*** |
| ⑤ | Mid profile | P 061115 |
| ⑥ | Rail | P 061112 |
| ⑦ | Flymesh Sash | P 660055 |
| ⑧ | Glazing gasket | Z 061808*** |
| ⑨ | Woven pile | Z 663032*** |
| ⑩ | Cover foam | Z 060811 |
| ⑪ | PVC Gasket | Z 918565 |
| ⑫ | Interlock gasket | Z 061815 |
| ⑬ | PVC interlock | K 061001 |
| ⑭ | Shaped plastic piece | Z 061503 |
| ⑮ | Mid transom | B 061302 |
| ⑯ | Beading | P 816603 |
| ⑰ | Alum. packer | Z 000000 |
| ⑱ | Glazing gasket in | Z 914259*** |
| ⑲ | Glazing gasket out | Z 912612*** |

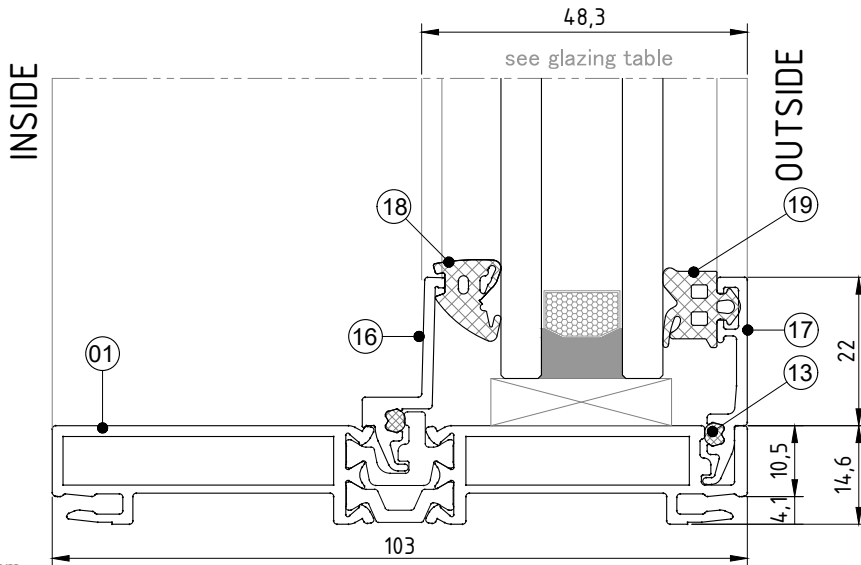

*** optional item

⊛ for high performance use bulb gasket (Z 913154) instead of brush

12/2022

Window - Double track vertical section

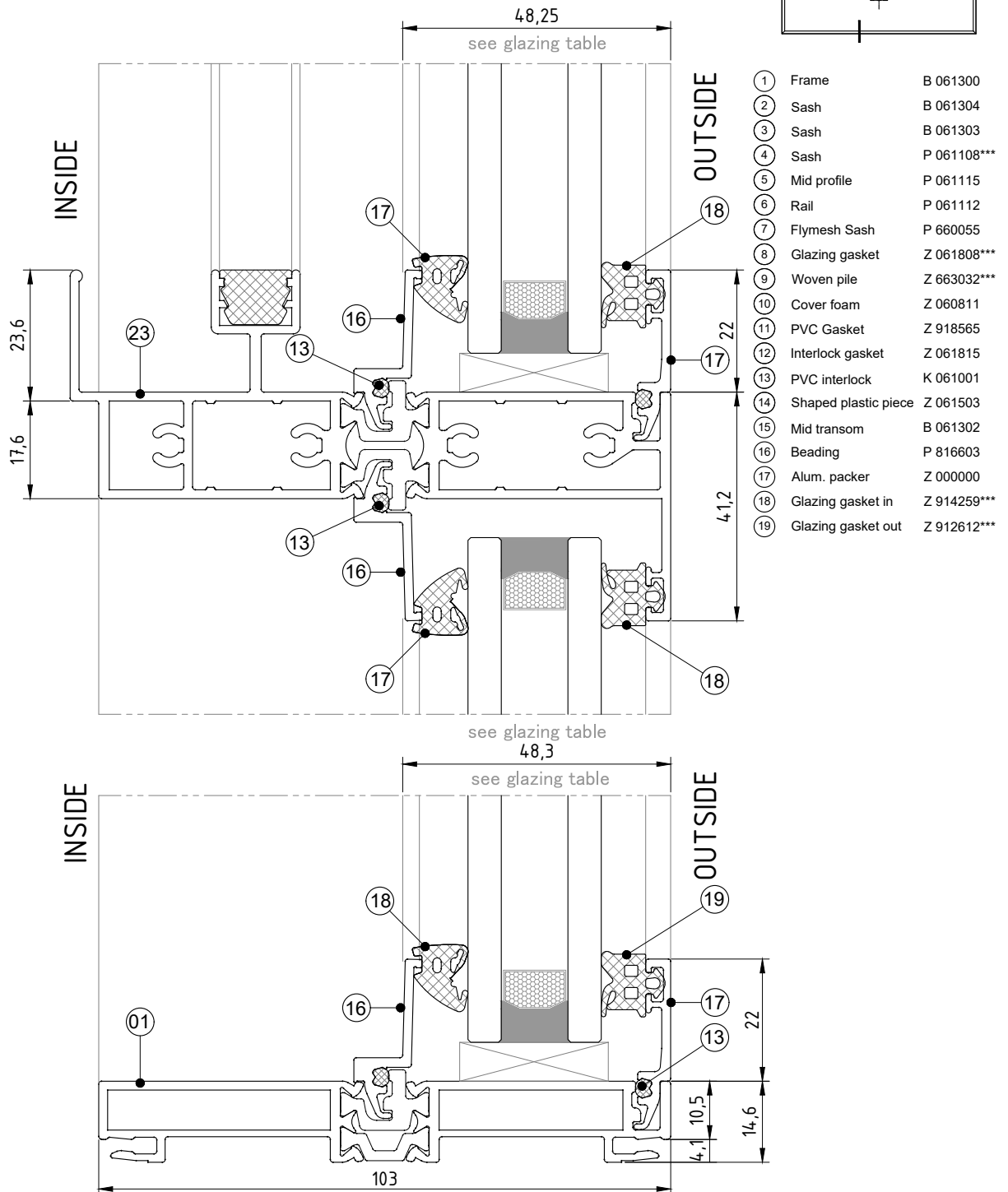
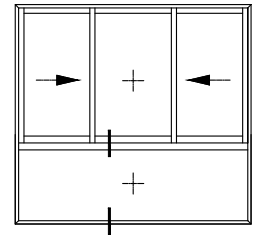

*** optional item

⊕ for high performance use bulb gasket (Z 913154) instead of brush

12/2022

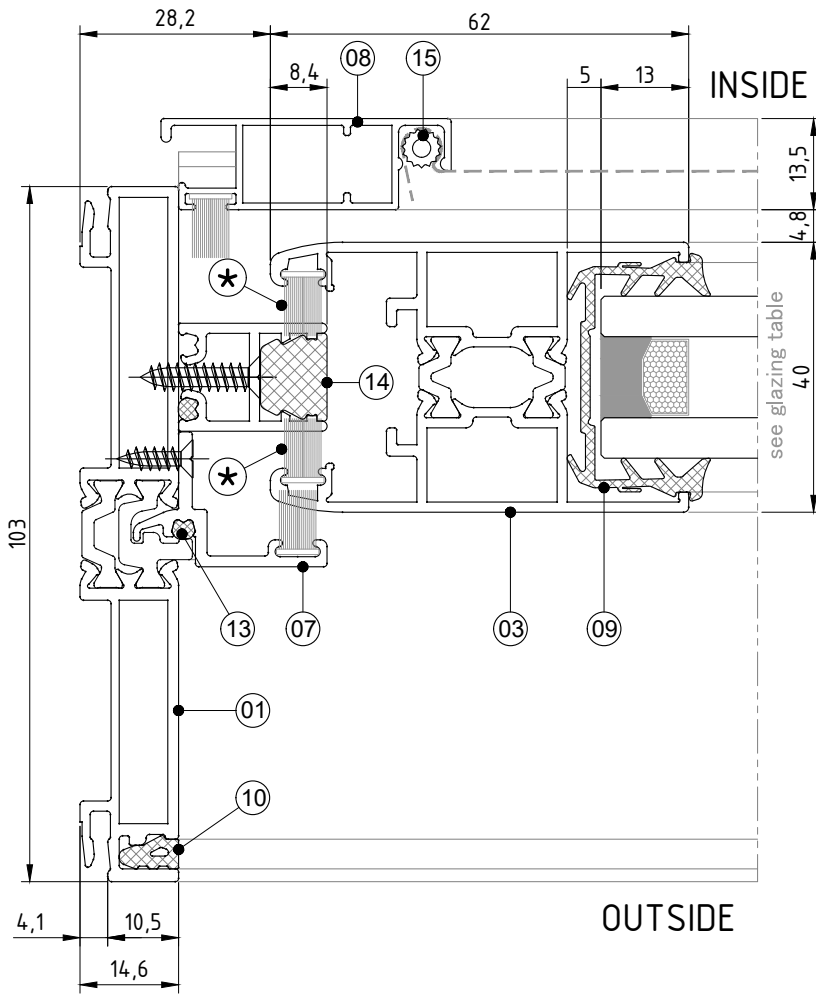
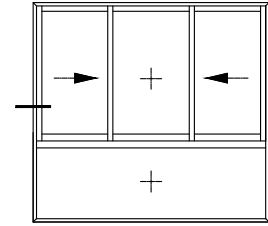

①	Frame	B 061300
②	Sash	B 061304
③	Sash	B 061303
④	Sash	P 061108***
⑤	Mid profile	P 061115
⑥	Rail	P 061112
⑦	Flymesh Sash	P 660055
⑧	Glazing gasket	Z 061808***
⑨	Woven pile	Z 663032***
⑩	Cover foam	Z 060811
⑪	PVC Gasket	Z 918565
⑫	Interlock gasket	Z 061815
⑬	PVC interlock	K 061001
⑭	Shaped plastic piece	Z 061503
⑮	Mid transom	B 061302
⑯	Beading	P 816603
⑰	Alum. packer	Z 000000
⑱	Glazing gasket in	Z 914259***
⑲	Glazing gasket out	Z 912612***

Sections / Details

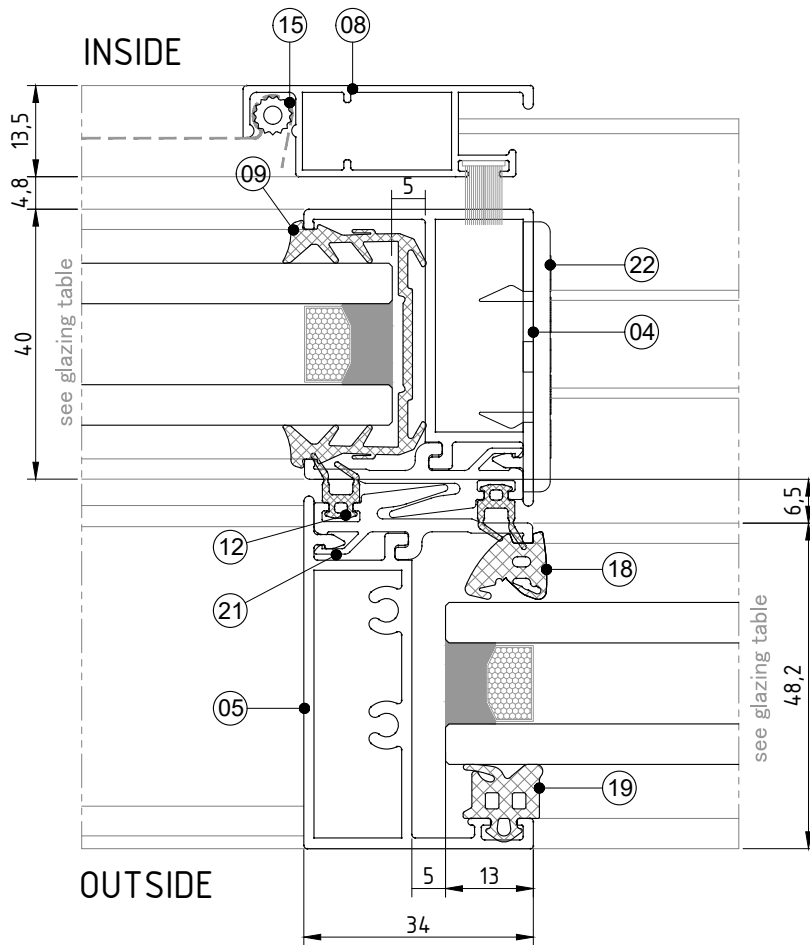
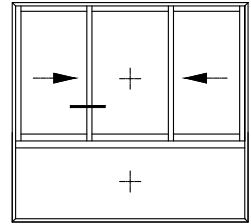

①	Frame	B 061300
②	Sash	B 061304
③	Sash	B 061303
④	Sash	P 061108***
⑤	Mid profile	P 061115
⑥	Rail	P 061112
⑦	Flymesh Sash	P 660055
⑧	Glazing gasket	Z 061808***
⑨	Woven pile	Z 663032***
⑩	Cover foam	Z 060811
⑪	PVC Gasket	Z 918565
⑫	Interlock gasket	Z 061815
⑬	PVC interlock	K 061001
⑭	Shaped plastic piece	Z 061503
⑮	Mid transom	B 061302
⑯	Beading	P 816603
⑰	Alum. packer	Z 000000
⑱	Glazing gasket in	Z 914259***
⑲	Glazing gasket out	Z 912612***

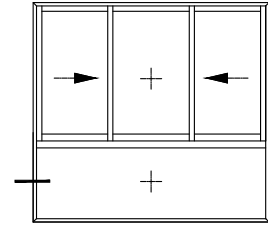

- | | | |
|---|----------------------|-------------|
| ① | Frame | B 061300 |
| ② | Sash | B 061304 |
| ③ | Sash | B 061303 |
| ④ | Sash | P 061108*** |
| ⑤ | Mid profile | P 061115 |
| ⑥ | Rail | P 061112 |
| ⑦ | Flymesh Sash | P 660055 |
| ⑧ | Glazing gasket | Z 061808*** |
| ⑨ | Woven pile | Z 663032*** |
| ⑩ | Cover foam | Z 060811 |
| ⑪ | PVC Gasket | Z 918565 |
| ⑫ | Interlock gasket | Z 061815 |
| ⑬ | PVC interlock | K 061001 |
| ⑭ | Shaped plastic piece | Z 061503 |
| ⑮ | Mid transom | B 061302 |
| ⑯ | Beading | P 816603 |
| ⑰ | Alum. packer | Z 000000 |
| ⑱ | Glazing gasket in | Z 914259*** |
| ⑲ | Glazing gasket out | Z 912612*** |

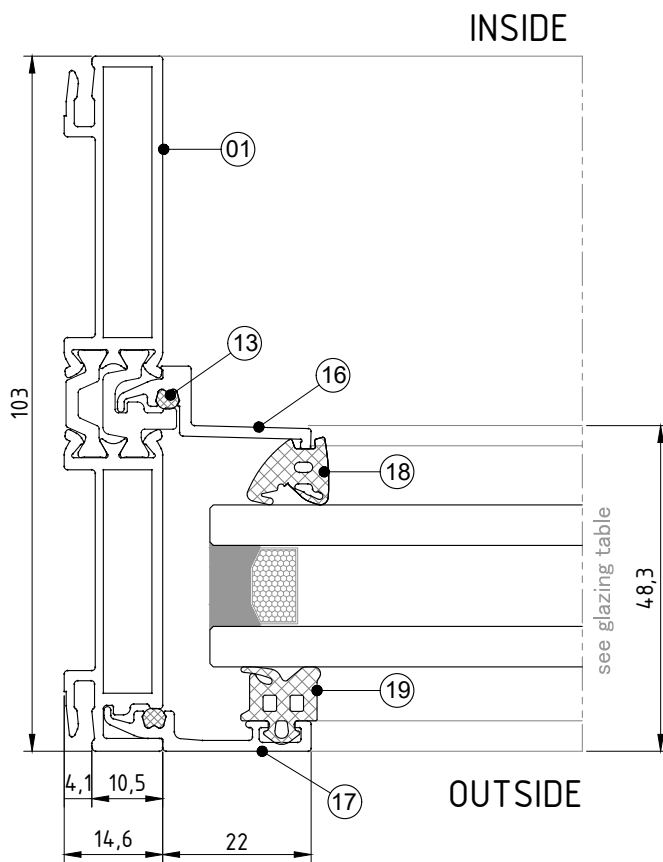

Sections / Details

Door - Double track horizontal section

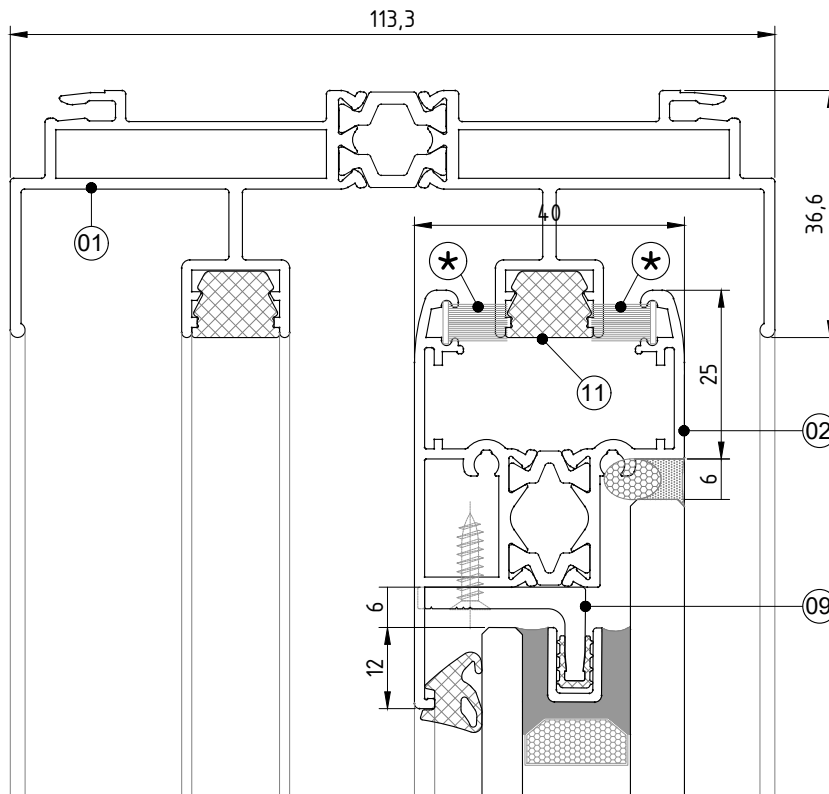

- | | | |
|---|----------------------|-------------|
| ① | Frame | B 061300 |
| ② | Sash | B 061315 |
| ③ | Sash | B 061314 |
| ④ | Sash | P 061149 |
| ⑤ | Sash | P 061150 |
| ⑥ | Mid profile | P 061115 |
| ⑦ | Rail | P 061140 |
| ⑧ | Flymesh Sash | P 660055 |
| ⑨ | Toggle | P 061151 |
| ⑩ | Woven pile | Z 663032*** |
| ⑪ | Cover foam | Z 060811 |
| ⑫ | PVC Gasket | Z 918565 |
| ⑬ | Interlock gasket | Z 061815 |
| ⑭ | PVC interlock | Z 061526 |
| ⑮ | Shaped plastic piece | Z 061527 |
| ⑯ | Internal push gasket | Z 914261 |

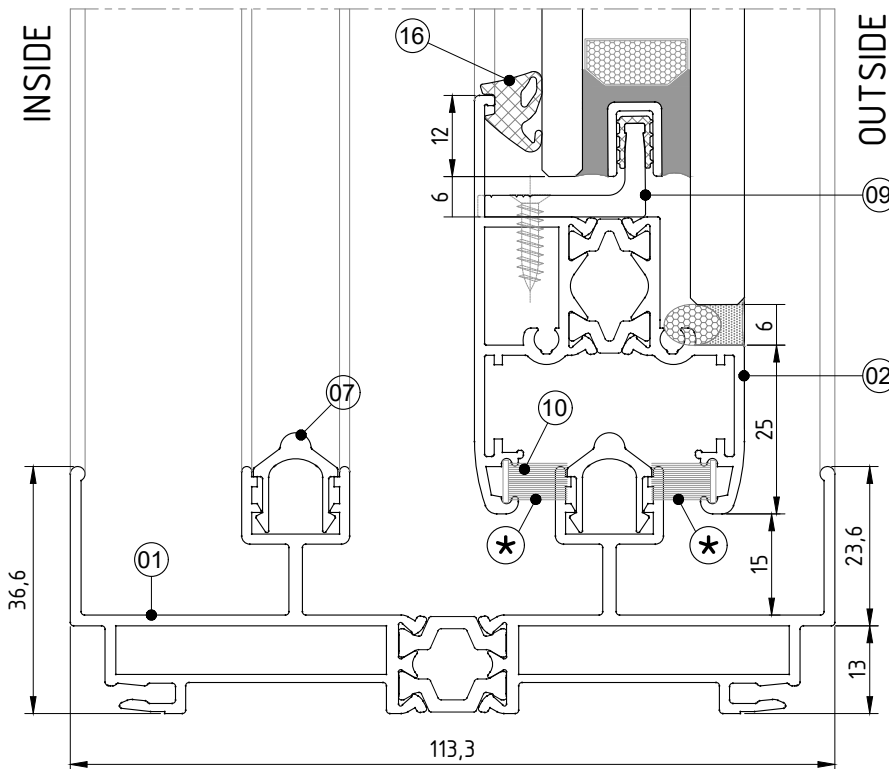

*** optional item

⊛ for high performance use bulb gasket (Z 913154) instead of brush

12/2022

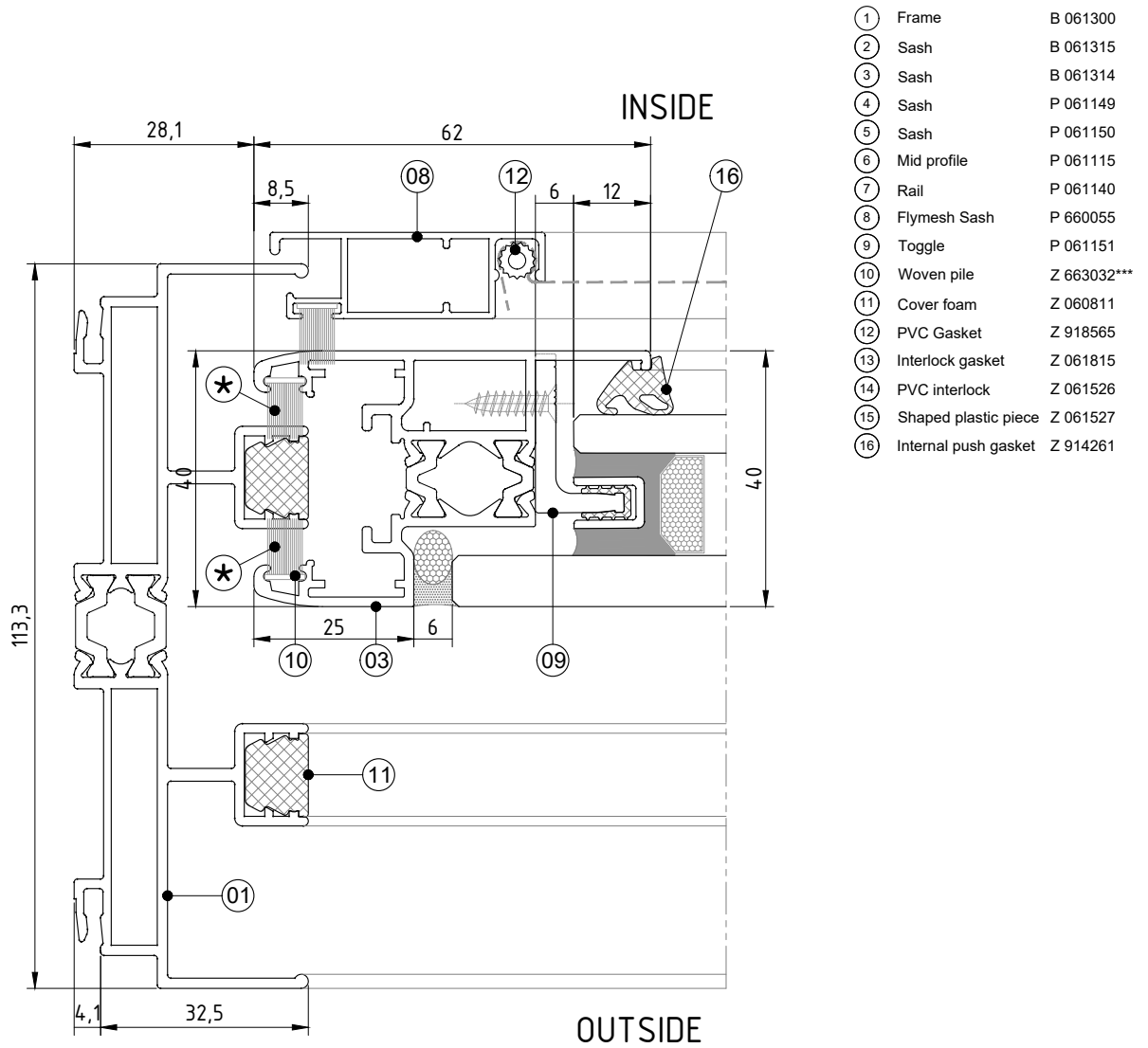
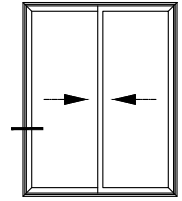

*** optional item

⊕ for high performance use bulb gasket (Z 913154) instead of brush

12/2022



Volato

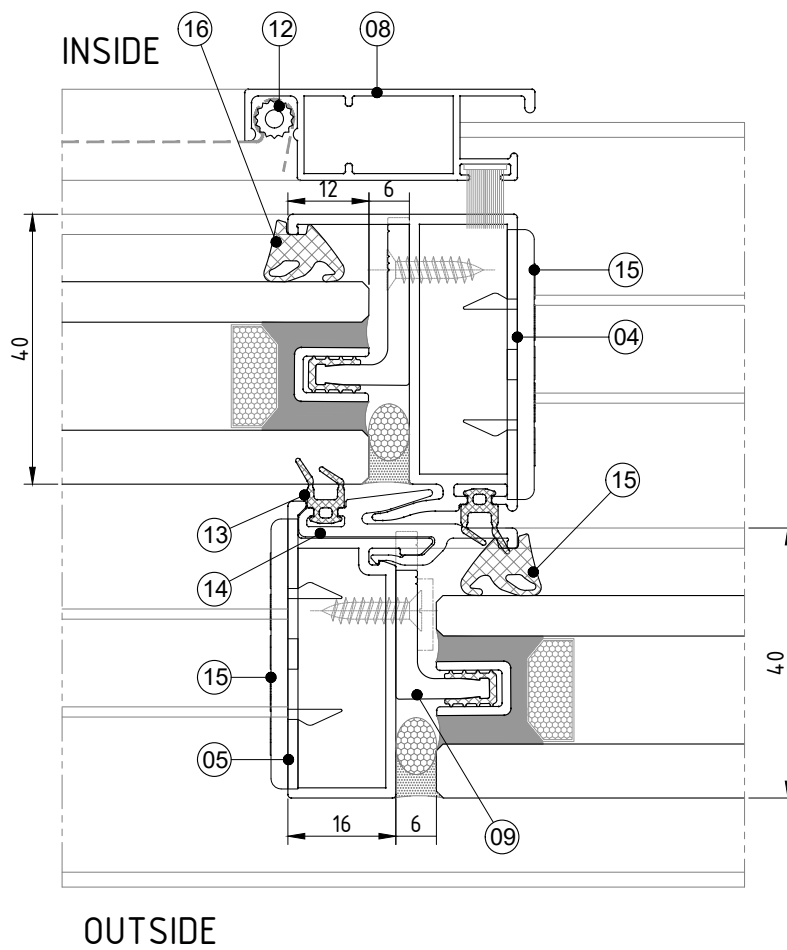
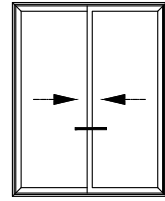

- | | | |
|---|----------------------|-------------|
| ① | Frame | B 061300 |
| ② | Sash | B 061315 |
| ③ | Sash | B 061314 |
| ④ | Sash | P 061149 |
| ⑤ | Sash | P 061150 |
| ⑥ | Mid profile | P 061115 |
| ⑦ | Rail | P 061140 |
| ⑧ | Flymesh Sash | P 660055 |
| ⑨ | Toggle | P 061151 |
| ⑩ | Woven pile | Z 663032*** |
| ⑪ | Cover foam | Z 060811 |
| ⑫ | PVC Gasket | Z 918565 |
| ⑬ | Interlock gasket | Z 061815 |
| ⑭ | PVC interlock | Z 061526 |
| ⑮ | Shaped plastic piece | Z 061527 |
| ⑯ | Internal push gasket | Z 914261 |

Sections / Details

*** optional item

⊛ for high performance use bulb gasket (Z 913154) instead of brush

12/2022

- ① Frame B 061300
- ② Sash B 061315
- ③ Sash B 061314
- ④ Sash P 061149
- ⑤ Sash P 061150
- ⑥ Mid profile P 061115
- ⑦ Rail P 061140
- ⑧ Flymesh Sash P 660055
- ⑨ Toggle P 061151
- ⑩ Woven pile Z 663032***
- ⑪ Cover foam Z 060811
- ⑫ PVC Gasket Z 918565
- ⑬ Interlock gasket Z 061815
- ⑭ PVC interlock Z 061526
- ⑮ Shaped plastic piece Z 061527
- ⑯ Internal push gasket Z 914261

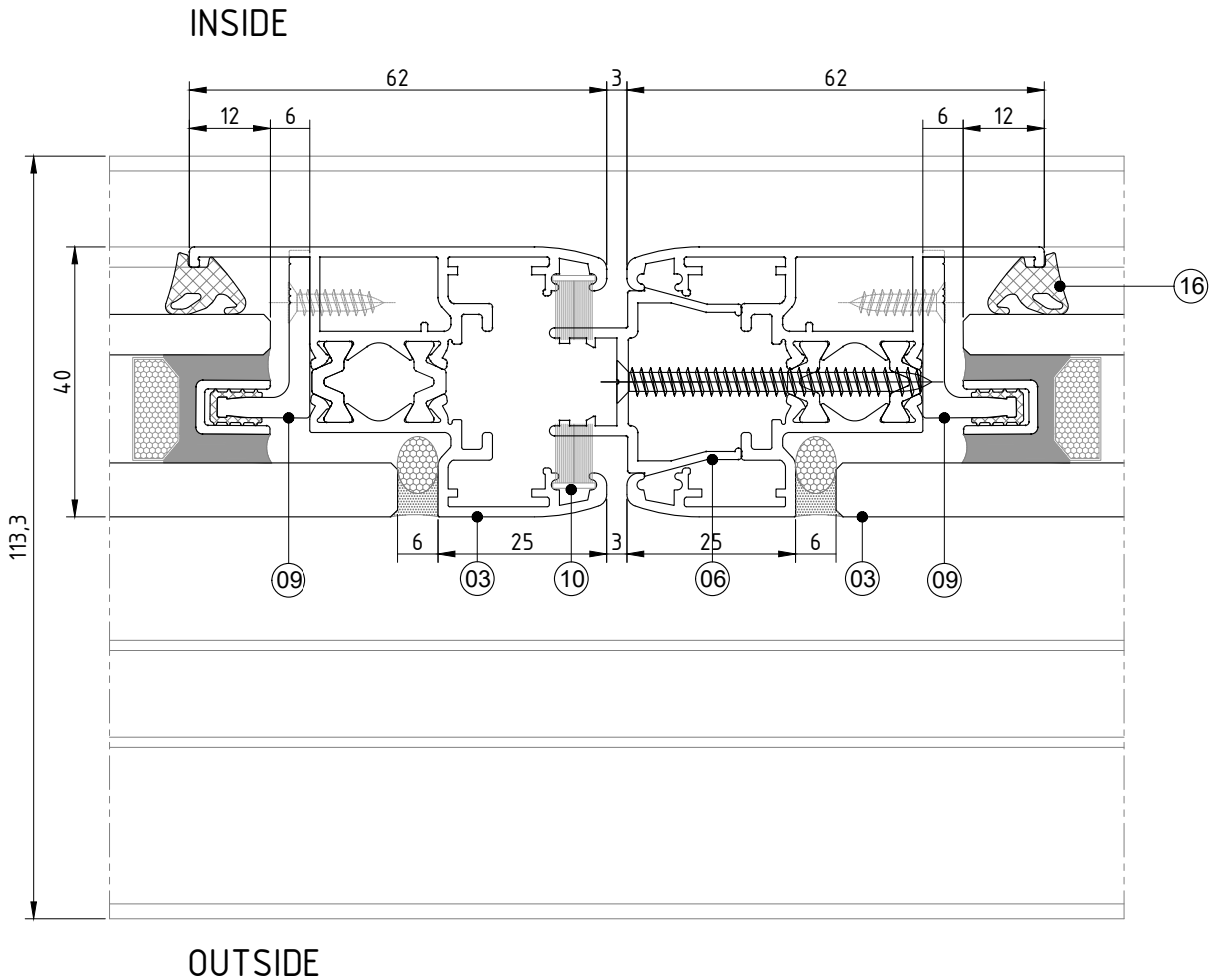
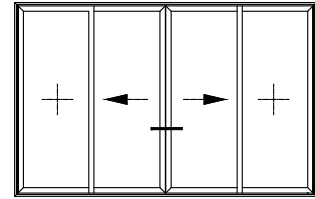

*** optional item

⊛ for high performance use bulb gasket (Z 913154) instead of brush

12/2022

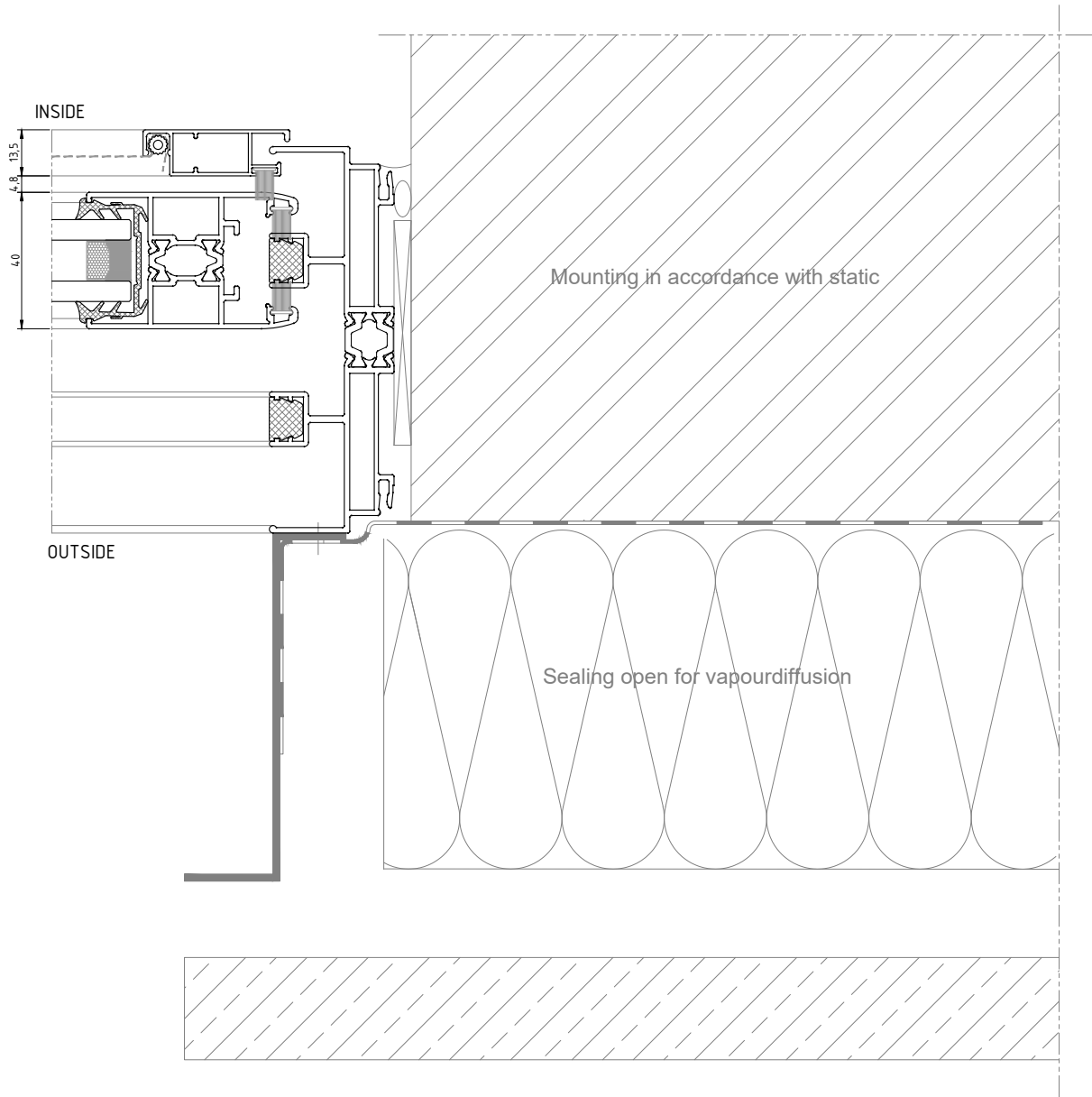

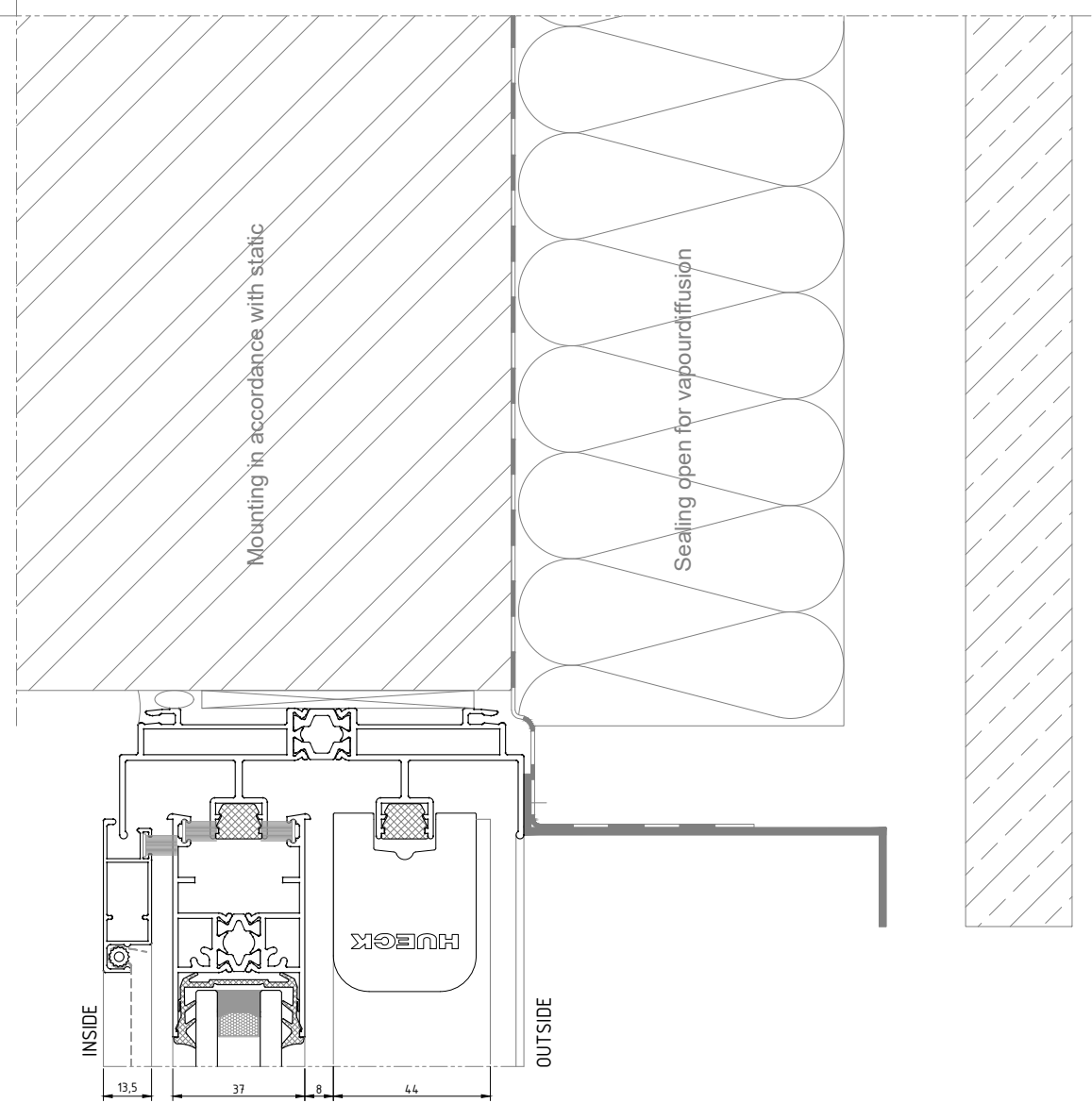

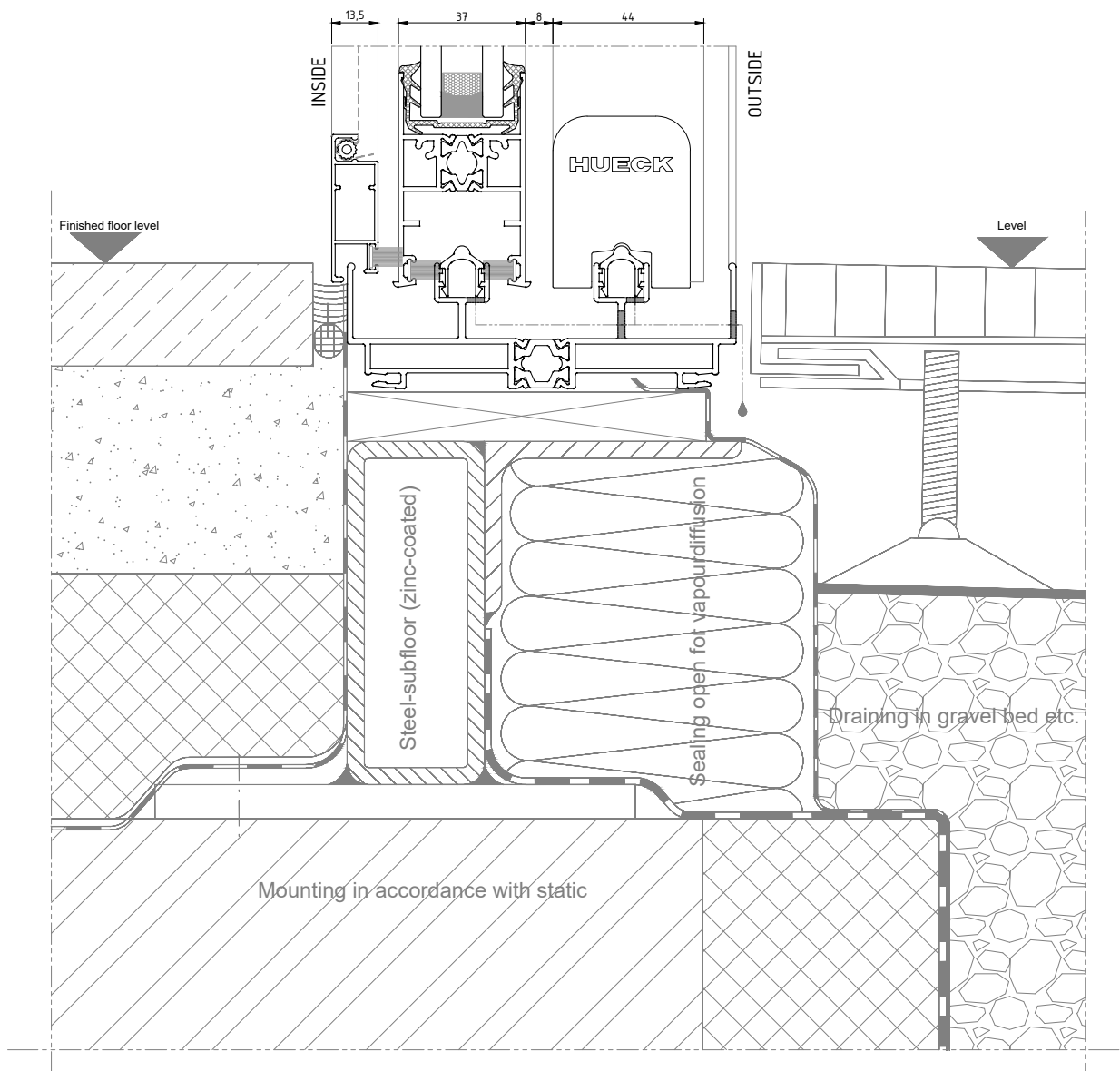

HUECK

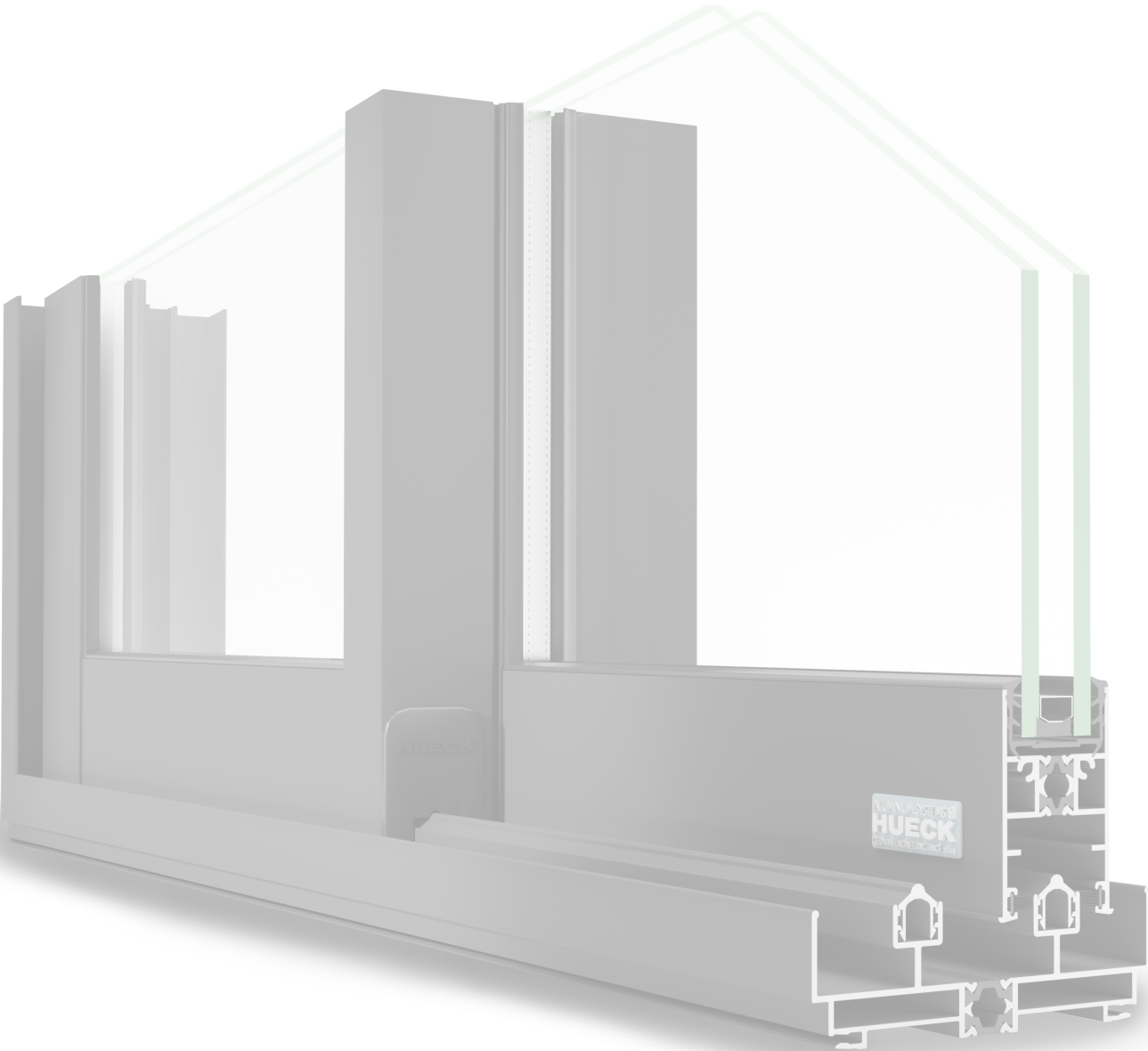

12/2022

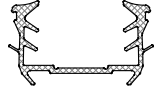

Z 061808 22

Glazing gasket
for glass thickness of 24 mm glass
EPDM, black
Surface: siliconised

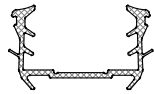

Z 061800 22

Glazing gasket
for glass thickness of 26 mm glass
EPDM, black
Surface: siliconised

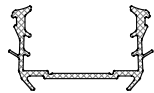

Z 061811 22

Glazing gasket
for glass thickness of 28 mm glass
EPDM, black
Surface: siliconised

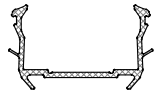

Z 061803 22

Glazing gasket
for glass thickness of 30 mm glass
EPDM, black
Surface: siliconised



Z 918350 22

Glazing gasket -outside-
for gap dimensions of 2 mm
EPDM, black
Surface: siliconised



Z 912611 22

Glazing gasket -outside-
for gap dimensions of 4 mm
EPDM, black
Surface: siliconised

Installation: refer to processing information

12/2022



Z 912612 22

Glazing gasket -outside-
for gap dimensions of 6 mm
EPDM, black
Surface: siliconised



Z 912613 22

Glazing gasket -outside-
for gap dimensions of 8 mm
EPDM, black
Surface: siliconised



Z 914259 22

Glazing gasket -internal-
for gap dimensions of 4.5 - 6.5 mm
EPDM, black
Surface: siliconised



Z 914260 22

Glazing gasket -internal-
for gap dimensions of 5.5 - 7.5 mm
EPDM, black
Surface: siliconised

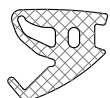

Z 914261 22

Glazing gasket -internal-
for gap dimensions of 6.5 - 9.5 mm
EPDM, black
Surface: siliconised



Z 061812

Woven pile weather strip
6.3 x 9.5 mm, black



Z 918565

PVC Gasket
for Fly screen

Installation: refer to processing information

12/2022



Z 923154

Bulb gasket
black
for high performance



Z 061815 22

Interlock gasket
EPDM, black
Surface: siliconised

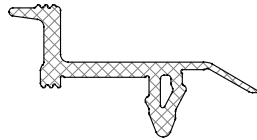

Z 061806 22

Cover gasket, (monorail frame bottom)
EPDM, black
Surface: siliconised



Z 061807 22

groove gasket, (monorail frame groove)
EPDM, black
Surface: siliconised



Z 902161

Gasket cord
rubber foam, dark grey,
Ø 3 mm
for sealing the external snap-in profiles

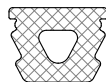

Z 060811

Cover foam
rubber foam, black,
for covering exposed rail profile

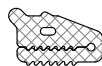

Z 061813

Gasket
EPDM, black,
for roller packer block

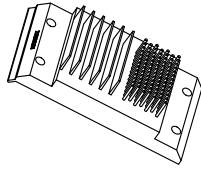

Z 061801

Center seal gasket, shaped piece, EPDM, black, for the sealing in the labyrinth area

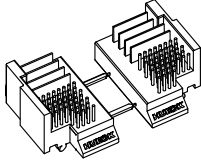

Z 061810

Center seal gasket at monorail, shaped piece (pair left + right), EPDM, black, for the sealing in the labyrinth area

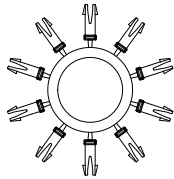

Z 918385

Nail for center seal gasket Z 918384, shaped plastic piece, black

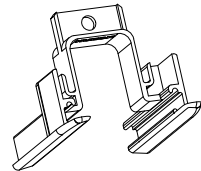

Z 061502

Cover labyrinth, lock side, shaped plastic piece, black

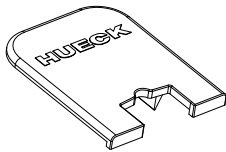

Z 061503

Cover labyrinth area, shaped plastic piece, black

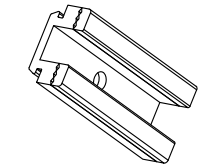

Z 060800

Stop buffer 30mm EPDM, black,

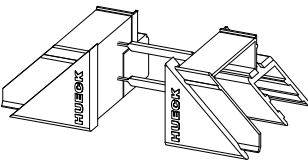

Z 061521

Miter cap (pair left + right) shaped plastic piece, black

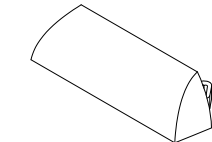

Z 918505

Drainage cap without membrane, shaped plastic piece, black

Installation: refer to processing information

System dependent accessories

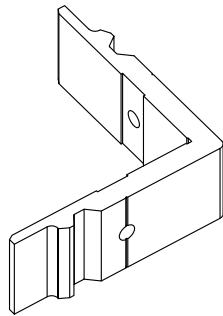

Z 061505

Corner bracket 39.7mm
(from profile P 499605)

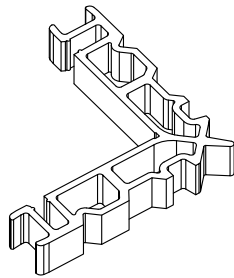

Z 061506

Corner bracket 32.7mm
(from profile P 499605)

Z 061507

Corner bracket 26.5mm
(from profile P 499605)

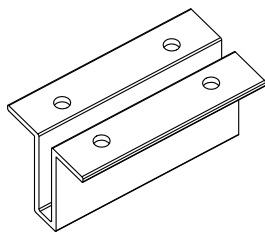

Z 663033

Corner bracket 11.1mm
(from profile P 599343)

Z 061508

Distance piece for fixed field,
(from profile P 061107)



Z 911513

Spring pin for corner bracket,
bracket external,
5 x 8 mm

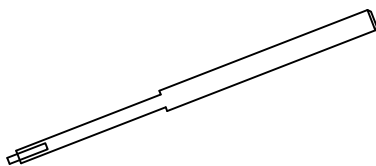

Z 911187

Mandrel to drive in t-bracket for
spring pin, r 5mm

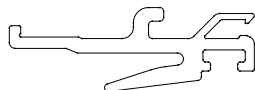

K 061001

For interlock profile
PVC, black



K 061526

For interlock profile
PVC, black

Installation: refer to processing information



Z 913239

Screw,
for sliding sash (lock side)
DIN 7982 4,2 x 40



Z 906602

Screw,
for mid transom
DIN 7982 4.8 x 32



Z 901499

Screw,
for sliding sash (labyrinth side)
DIN 7982 4,2 x 22

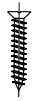

Z 900656

Screw,
for fixed sash (at labyrinth)
DIN 7982 3.9 x 19



Z 900235

Screw,
for fixed sash (at distance piece)
DIN 7981 3.9 x 16



Z 911050

Screw,
DIN 7504 3,5 x 16



Z 663034

Hole cap for Ø12mm hole
EPDM, black,
(other color on demand)

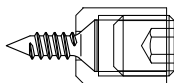

Z 993546

Lift out safety device

Installation: refer to processing information

12/2022

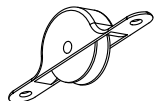

Z 018711

Single roller fixed (fly screen)

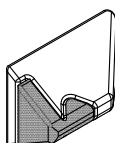

Z 060521

Sliding bumper

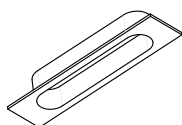

Z 669040

Embedded handle (fly screen)



Z 918565

PVC gasket for fly screen

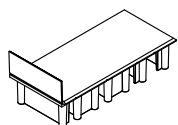

Z 061525

End cap for interlock profile

Installation: refer to processing information

12/2022



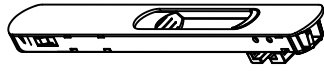

Z 061504

Inner click fast mounting
embedded handle - automatic;



Z 061529

Inner click fast mounting
embedded handle - automatic;



Z 061530

(flush dummy handle)



Z061519

(flush spindle handle)



Z061520

(flush dummy handle)

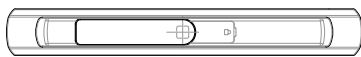

Z061524

(flush spindle handle)

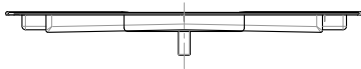

Z 061518

Gear box - multi locking

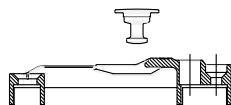

Z061501

(locking pin)

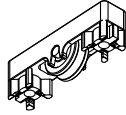

Z 061522

Single roller (sliding)
50 kg / pair

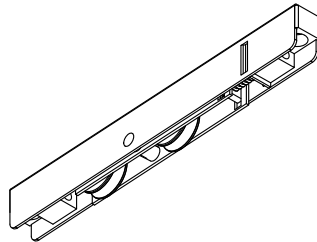

Z 061510

Double roller adjustable (sliding)
120 kg / pair

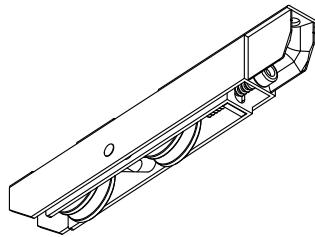

Z 061513

Double roller adjustable (sliding)
200 kg / pair

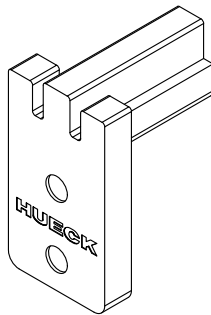

Z 061533

Top cover (Anti shaking)

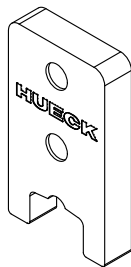

Z 061534

Bottom cover (Anti shaking)

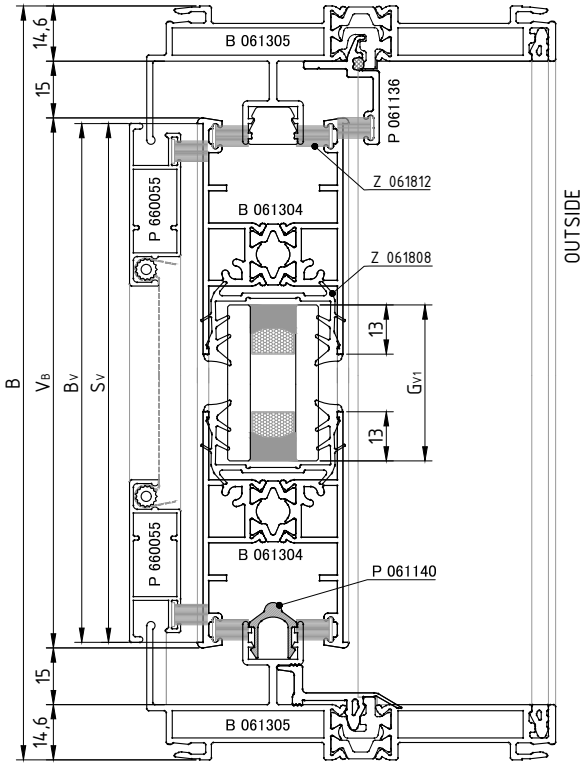

SECTION A-A

G_{v1} & G_{v2} = see glass dimension

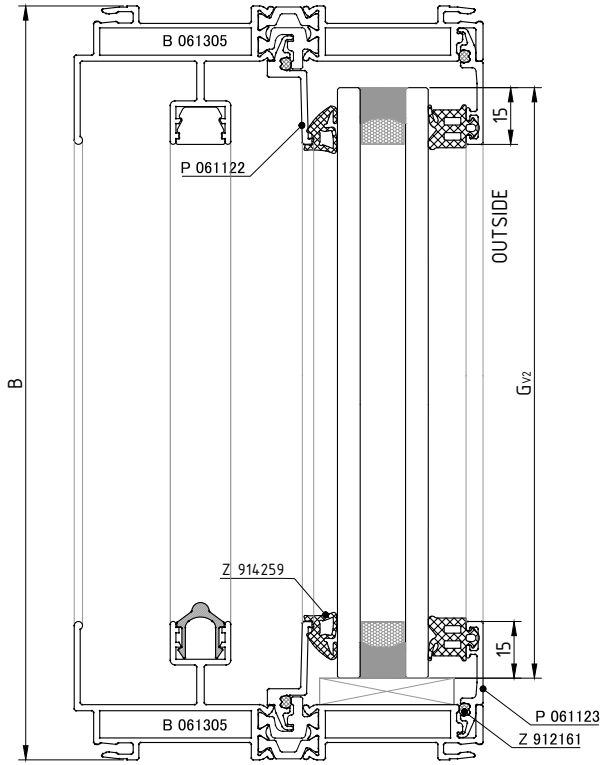

SECTION B-B

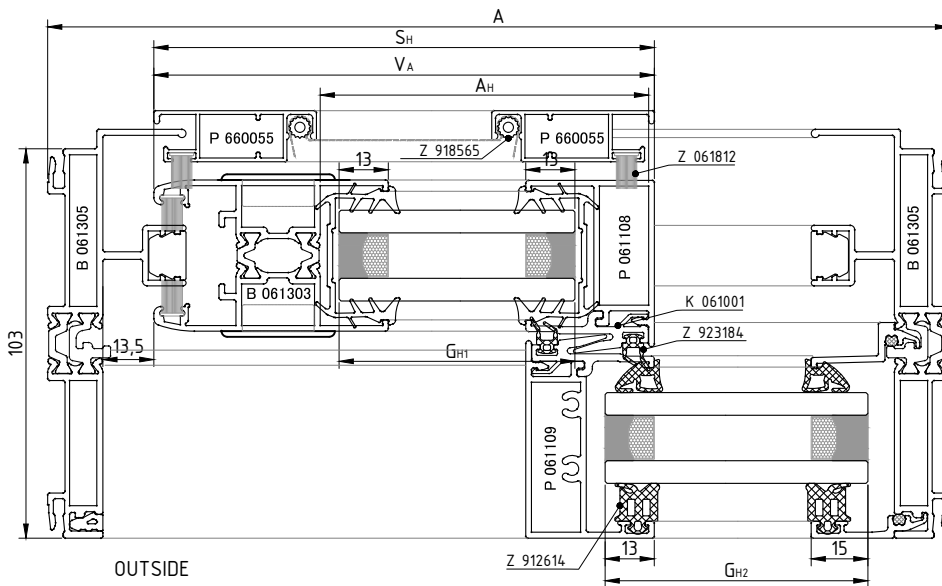

G_{H1} & G_{H2} = see glass dimension

PLAN C-C

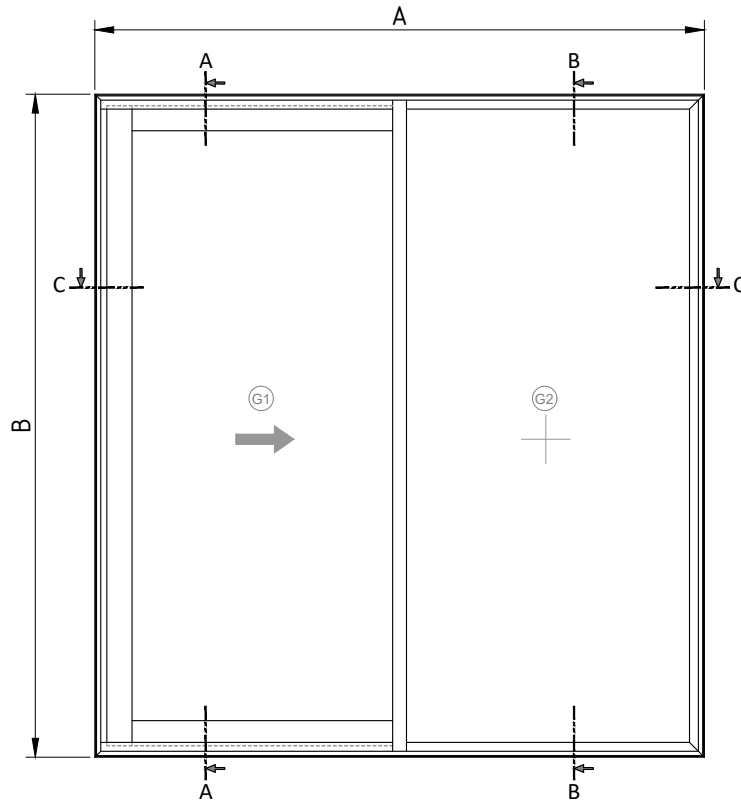

MATERIAL LIST				
Description	Part no.	Calculation	Qty.	Cut
Frame horizontal	B 061305	A= horizontal element dimension	2x	\-----/
Frame vertical	B 061305	B=vertical element dimension	2x	-----
Vent horizontal		V _A = (A/2) - 11.1		
Vent vertical		V _B = B - 59.2		
Vent profile horizontal	B 061304	A _H = (A/2) - 56.6	2x	-----
Vent Vertical (lock side)	B 061303	B _{V1} = B - 62.2	1x	-----
Vent Vertical (labyrinth side)	P 061108	B _{V2} = B - 62.2	1x	-----
Fix frame vertical (monorail)	P 061109	B _{V3} = B - 29.2	1x	-----
Running Rail (Track)	P 061140	= A - 73.2	1x	-----
Beading - center vertical	P 061122	dc1 = B - 15.8	1x	\-----/
Beading - center horizontal	P 061122	dc2 = (A/2) - 24.9	2x	-----
Beading - outer vertical	P 061123	de1 = B - 11.8	1x	\-----/
Beading - outer horizontal	P 061123	de2 = (A/2) - 22.9	2x	-----
Top barrier profile	P 061136	dt1 = (A/2) - 31.6	1x	-----
Outer Frame Corner Cleat	P 499605	Z061505= 39.7mm	4x	-----
Outer Frame Corner Cleat	P 499605	Z061506= 32.7mm	4x	-----
Fly screen corner cleat	P 599343	Z663033= 11.1mm	4x	-----
Fly Screen Shutter - Horizontal	P 660055	S _H = V _A	2x	\-----/
Fly Screen Shutter - Vertical	P 660055	S _V = B - 62	2x	\-----/
PVC Interlock profile (for active sash)	K 061001	pi1 = B _{V1}	1x	-----
PVC Interlock profile (for monorail)	K 061001	pi2 = B - 73.2	1x	-----
Operating rod	H062007	= V _B - 600	1x	-----
Glass - G1		G _{H1} = ((A/2) - 81), G _{V1} = (B - 158)	1x	-
Glass - G2		G _{H2} = ((A/2) - 25.7), G _{V2} = (B - 43.2)	1x	-

MATERIAL LIST				
Description	Part no.	Calculation	Qty.	Cut
U - Shape Gasket	see glazing table	= (G _{H1} + G _{V1}) X 2	LM	-
External glazing Gasket		= (G _{H2} + G _{V2}) X 2	LM	-
Internal push Gasket		= (G _{H2} + G _{V2}) X 2	LM	-
Interlocking Gasket	Z 061815	= pi1 + pi2	LM	-
Weather Strip For Shutter	Z 061812	= (V _A + V _B) X 4	LM	-
Weather Strip For Fly Screen	Z 061812	= (S _H + S _V) X 2	LM	-
PVC Gasket For Fly Screen	Z 918565	= ((S _H - 70) + (S _V - 70)) X 2	LM	-
Seal Gasket For Outer Frame	Z 061807	= ((A/2) - 22) X 1 + ((B - 10) X 1)	LM	-
Sealing Cord For Beading	Z 902161	= dc1 + 2 + de1 + 2 + dt1	LM	-
Center Seal piece (L + R)	Z 061810	-	1x	-
Nail plastic	Z 918385	stop buffer & labyrinth cover assembly	4x	-
Cover, Lock Side	Z 061502	-	2x	-
Cover, Labyrinth	Z 061503	-	2x	-
Drainage Cap	Z 918505	-	2x	-
Roller For Fly Screen	Z 018711	-	2x	-
Handle For Fly Screen	Z 669049	-	2x	-
Sliding Bumper	Z 060521	-	1x	-
Stop Buffer	Z 060800	-	2x	-
Anti Lift Device	Z 993546	-	2x	-
Screw b4.2 x 40 DIN 7982	Z913239	sash assembly (lock side vent)	4x	-
Screw b4.2 x 22 DIN 7982	Z901499	sash assembly (labyrinth vent)	4x	-
Screw b4.2 x 22 DIN 7982	Z901499	Fix frame vertical assembly (monorail)	4x	-
Screw b3.5 x 16 DIN 7504 SO	Z911050	fly screen roller assembly, top barrier	7x	-

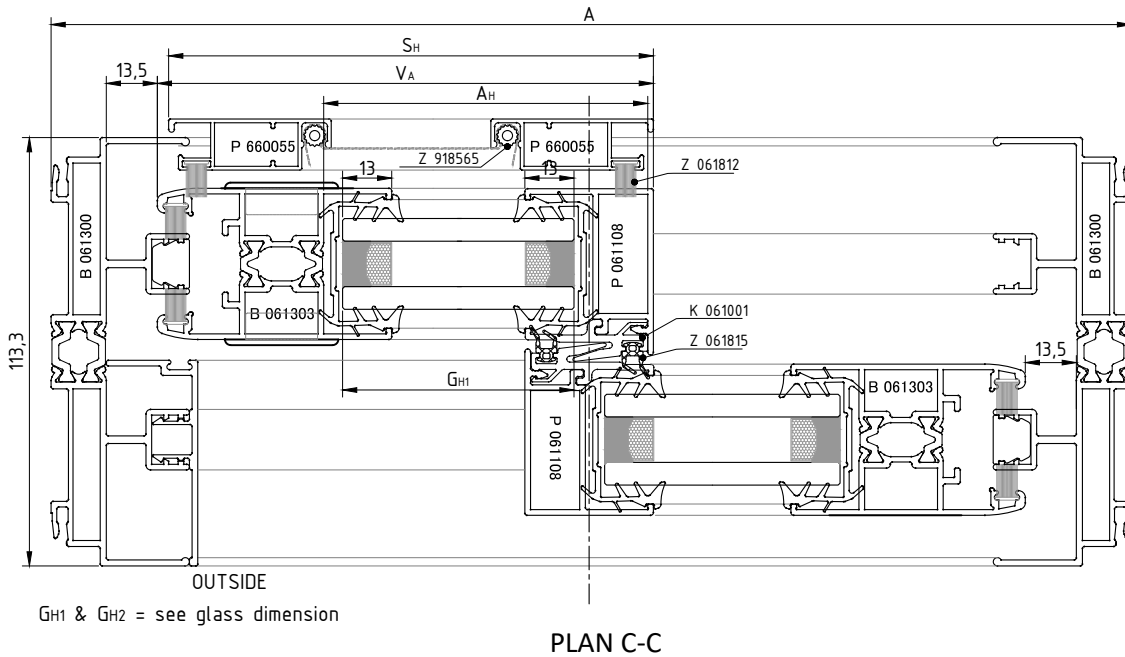
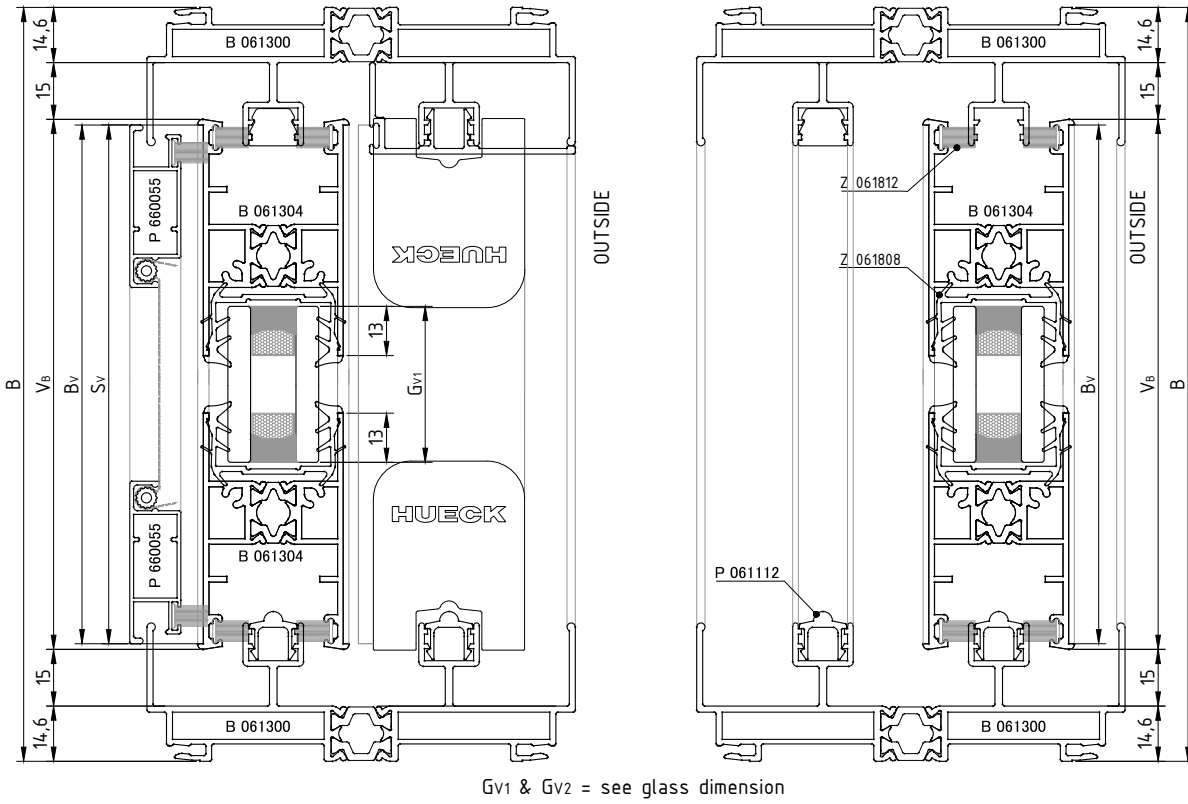

Processing

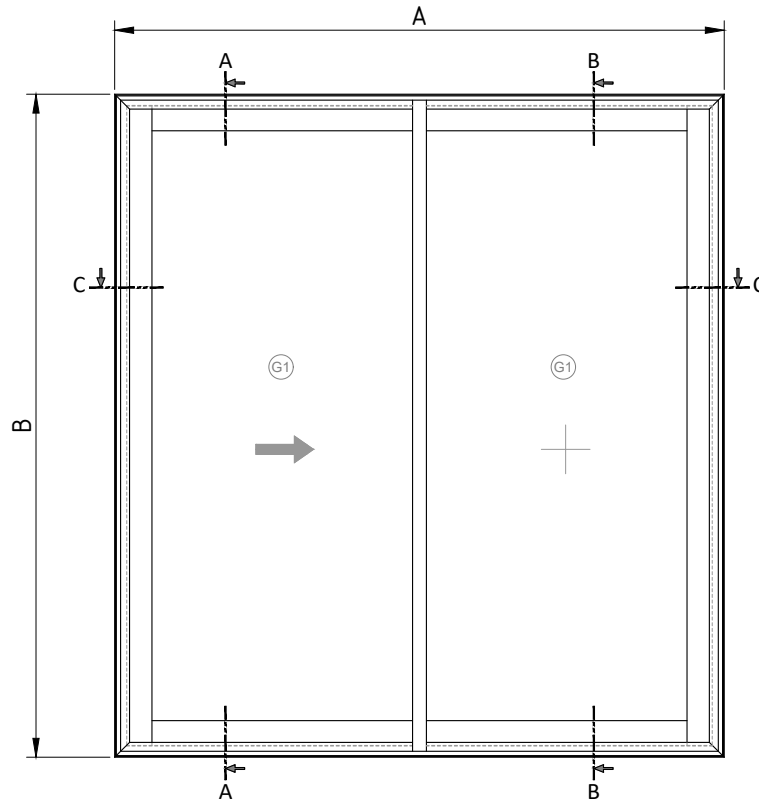

MATERIAL LIST				
Description	Part no.	Calculation	Qty.	Cut
Frame horizontal	B 061300	A= horizontal element dimension	2x	\\----/
Frame vertical	B 061300	B=vertical element dimension	2x	\\----/
Vent horizontal		$V_A = (A/2) - 11.1$		
Vent vertical		$V_B = B - 59.2$		
Vent profile horizontal	B 061304	$A_H = (A/2) - 56.6$	4x	----
Vent Vertical (lock side)	B 061303	$B_{V1} = B - 62.2$	2x	----
Vent Vertical (labyrinth side)	P 061108	$B_{V2} = B - 62.2$	2x	----
Running Rail (Track) for 50Kg Roller	P 061112	$= A - 73.2$	2x	----
Running Rail (Track) for 120Kg & 200Kg Roller	P 061140			
Outer Frame Corner Cleat	P 499605	2061505= 39.7mm	8x	----
Fly screen corner cleat	P 599343	2663033= 11.1mm	4x	----
Fly Screen Shutter - Horizontal	P 660055	$S_H = (A/2) - 14.5$	2x	\\----/
Fly Screen Shutter - Vertical	P 660055	$S_V = B - 62$	2x	\\----/
Fix sash support	P 061107	= Z 061508 (60mm long piece)	2x	----
Cover profile (top & bottom)	new	$= (A/2) - 53.6$	2x	----
Cover profile (side)	new	$= B - 77.6$	1x	----
PVC Interlock profile (for active sash)	K 061001	$pi1 = B_{V1}$	2x	----
Glass - G1		$G_{H1} = ((A/2) - 81)$, $G_{V1} = (B - 158)$	2x	-

MATERIAL LIST				
Description	Part no.	Calculation	Qty.	Cut
U - Shape Gasket	see glazing table	$= (G_{H1} + G_{V1}) \times 4$	LM	-
Interlocking Gasket	Z 061815	$= pi1 \times 2$	LM	-
Weather Strip For Shutter	Z 061812	$= (V_A + V_B) \times 8$	LM	-
Weather Strip For Fly Screen	Z 061812	$= (S_H + S_V) \times 2$	LM	-
PVC Gasket For Fly Screen	Z 918565	$= ((S_H - 70) + (S_V - 70)) \times 2$	LM	-
Center Seal piece	Z 061801	-	2x	-
Nail plastic	Z 918385	stop buffer & labyrinth cover assembly	10x	-
Cover, Lock Side	Z 061502	-	4x	-
Cover, Labyrinth	Z 061503	-	4x	-
Roller For Fly Screen	Z 018711	-	2x	-
Handle For Fly Screen	Z 669049	-	2x	-
Sliding Bumper	Z 060521	-	1x	-
Stop Buffer	Z 060800	-	4x	-
Anti Lift Device	Z 993546	-	4x	-
Screw b4.2 x 40 DIN 7982	Z913239	sash assembly (lock side vent)	8x	-
Screw b4.2 x 22 DIN 7982	Z901499	sash assembly (labyrinth vent)	8x	-
Screw b3.5 x 16 DIN 7504 SO	Z911050	fly screen roller assembly	4x	-
Screw b3.9 x 16 DIN 7981	Z900235	fix sash support fixing	8x	-
Screw b3.9 x 19 DIN 7982	Z900656	fix sash fixing	2x	-

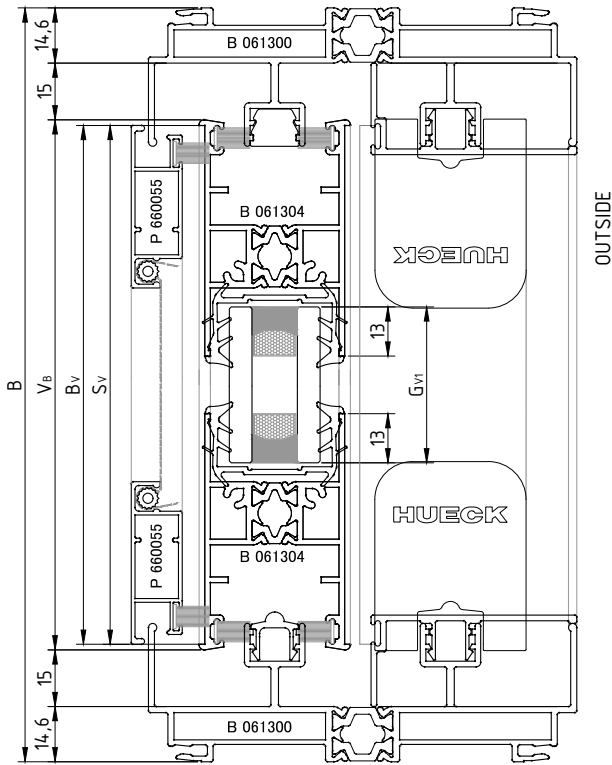

Gv1 & Gv2 = see glass dimension

SECTION A-A

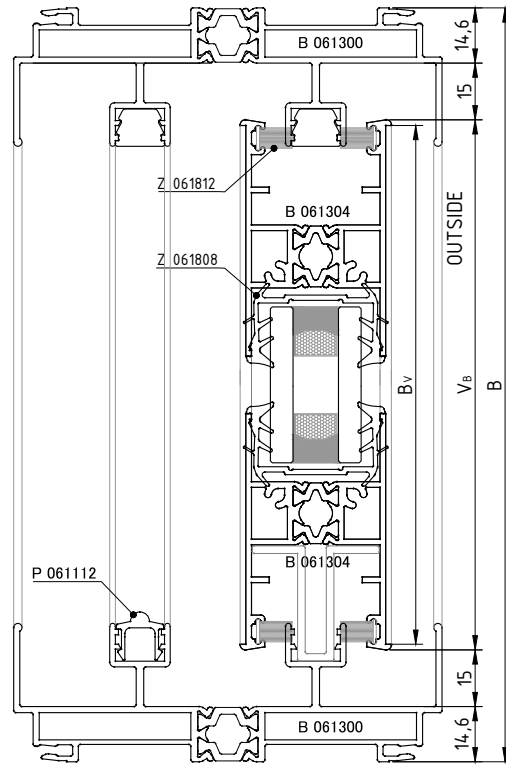

SECTION B-B

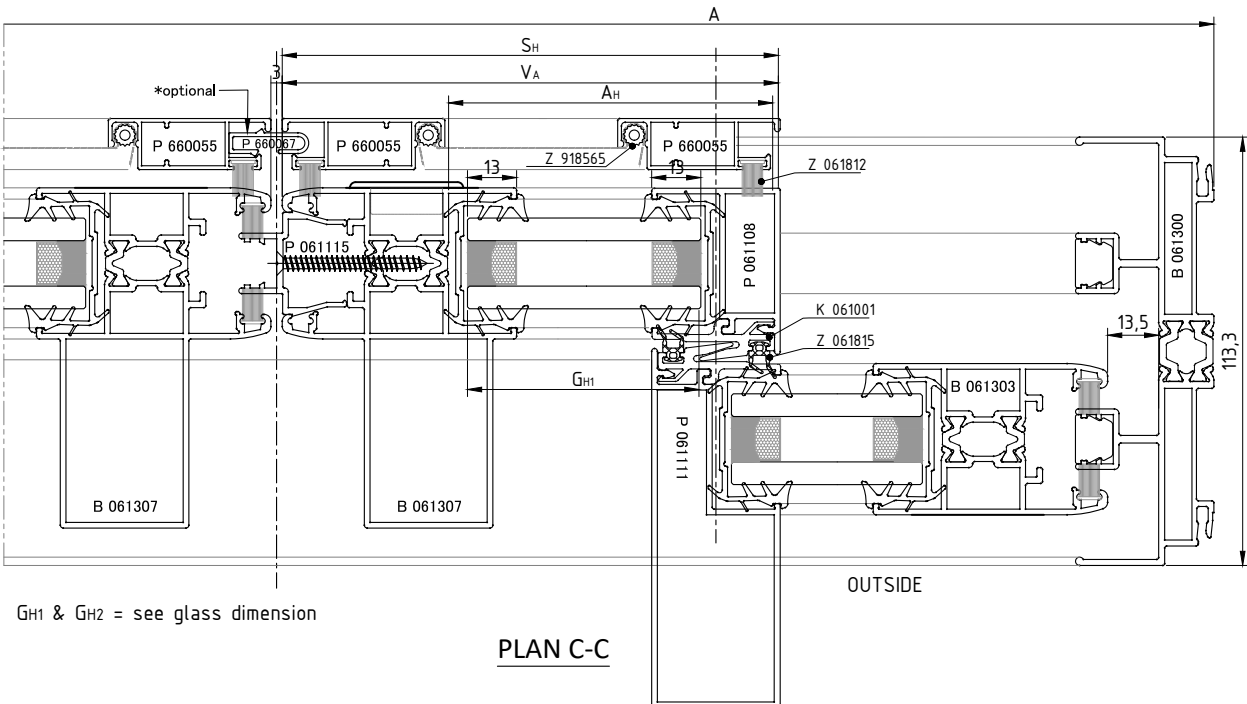

Gh1 & Gh2 = see glass dimension

PLAN C-C

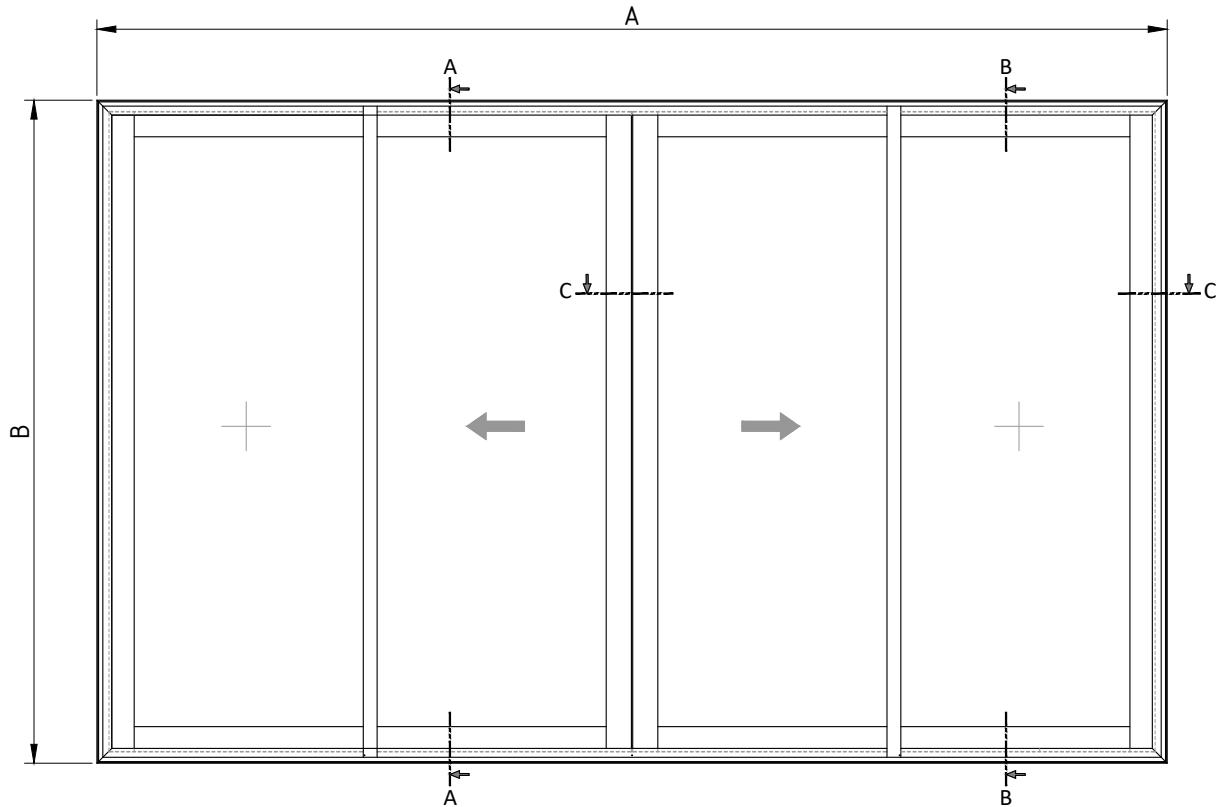

MATERIAL LIST				
Description	Part no.	Calculation	Qty.	Cut
Frame horizontal	B 061300	A= horizontal element dimension	2x	\----/
Frame vertical	B 061300	B=vertical element dimension	2x	\----/
Vent horizontal		$V_A = (A/4) + 2.1$		
Vent vertical		$V_B = B - 59.2$		
Vent profile horizontal	B 061304	$A_H = (A/4) - 43.3$	8x	----
Vent Vertical (lock side)	B 061307	$= B - 62.2$	2x	----
Vent Vertical	B 061303	$= B - 62.2$	2x	----
Vent Vertical (labyrinth side)	P 061108	$B_{V2} = B - 62.2$	2x	----
Vent Vertical structural (labyrinth side)	P 061111	$B_{V2} = B - 62.2$	2x	----
Running Rail (Track) for 50Kg Roller	P 061112			
Running Rail (Track) for 120Kg & 200Kg Roller	P 061140	$= A - 73.2$	2x	----
Outer Frame Corner Cleat	P 499605	Z061505= 39.7mm	8x	----
Fly screen corner cleat	P 599343	Z663033= 11.1mm	8x	----
Fly Screen Shutter - Horizontal	P 660055	$S_H = V_A$	4x	\----/
Fly Screen Shutter - Vertical	P 660055	$S_V = B - 62$	4x	\----/
Fix sash support	P 061107	$= Z 061508$ (60mm long piece)	4x	----
Cover profile (top & bottom)	P 061143	$= (A/2) - 61/2$	2x	----
meeting profile	P 061107	$= B_{V2}$	1x	----
Operating Rod	H 062007	$= V_B - 600$	1x	----
PVC Interlock profile (for active sash)	K 061001	$p_{I1} = B_{V2}$	4x	----
Glass - G1		$G_{H1} = ((A/4) - 68)$, $G_{V1} = (B - 158)$	4x	-

MATERIAL LIST				
Description	Part no.	Calculation	Qty.	Cut
U - Shape Gasket	see glazing table	$= (G_{H1} - G_{V1}) \times 8$	LM	-
Interlocking Gasket	Z 061815	$= p_{I1} \times 4$	LM	-
Weather Strip For Shutter	Z 061812	$= (V_A - V_B) \times 16$	LM	-
Weather Strip For Fly Screen	Z 061812	$= (S_H + S_V) \times 4$	LM	-
PVC Gasket For Fly Screen	Z 918565	$= ((S_H - 70) + (S_V - 70)) \times 4$	LM	-
Center Seal piece	Z 061801	-	4x	-
Nail plastic	Z 918385	stop buffer & labyrinth cover assembly	18x	-
Cover, Lock Side	Z 061502	-	8x	-
Cover, Labyrinth	Z 061503	-	8x	-
Roller For Fly Screen	Z 018711	-	4x	-
Handle For Fly Screen	Z 669049	-	2x	-
Sliding Bumper	Z 060521	-	2x	-
Stop buffer	Z 060800	-	6x	-
Anti Lift Device	Z 993546	-	8x	-
Screw b4.2 x 40 DIN 7982	Z913239	sash assembly (lock side vent)	16x	-
Screw b4.2 x 22 DIN 7982	Z901499	sash assembly (labyrinth vent)	16x	-
Screw b3.5 x 16 DIN 7504 SO	Z911050	fly screen roller assembly	8x	-
Screw b3.9 x 16 DIN 7981	Z900235	fix sash support fixing	16x	-
Screw b3.9 x 19 DIN 7982	Z900656	fix sash fixing	4x	-
Screw b4.2 x 40 DIN 7982	Z913239	meeting profile assembly	3x	-

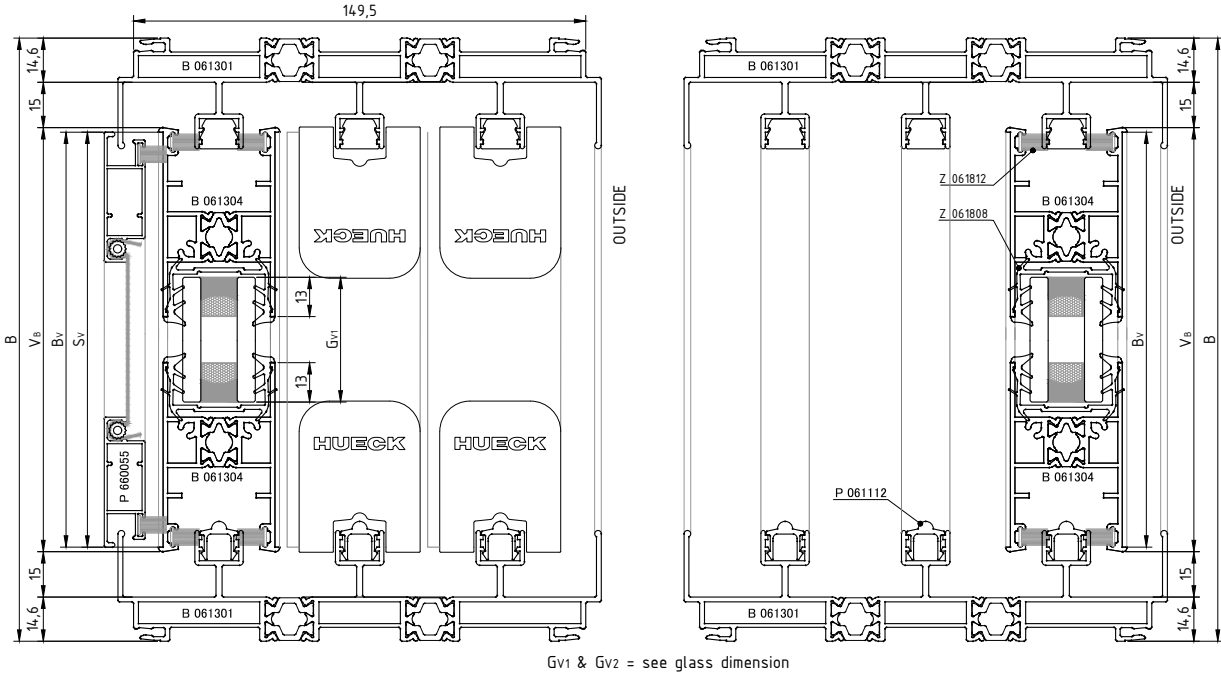

Gv1 & Gv2 = see glass dimension

SECTION A-A

SECTION B-B

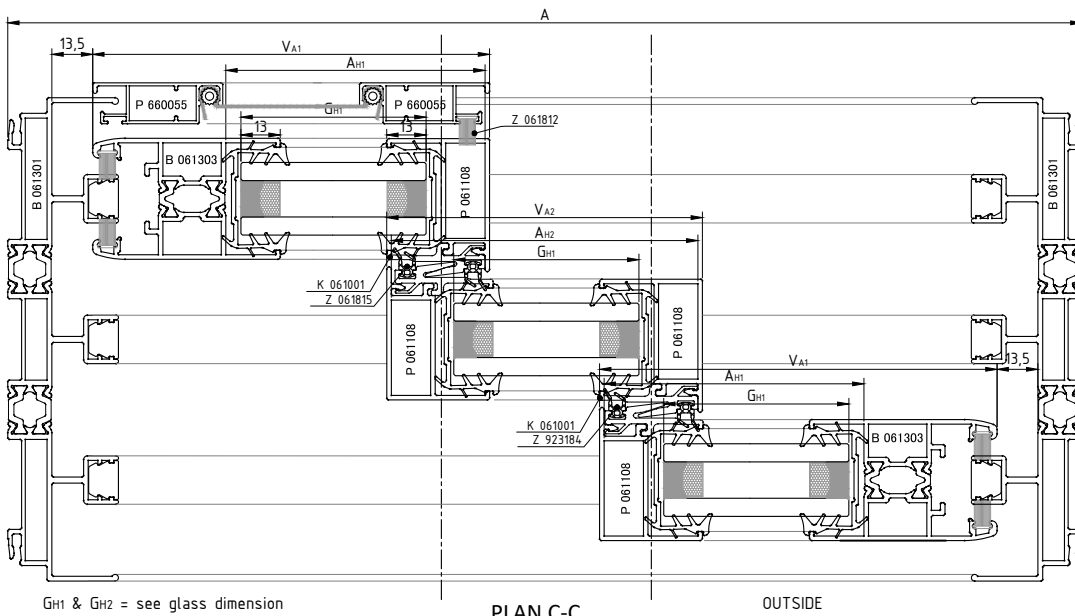

Gh1 & Gh2 = see glass dimension

PLAN C-C

OUTSIDE

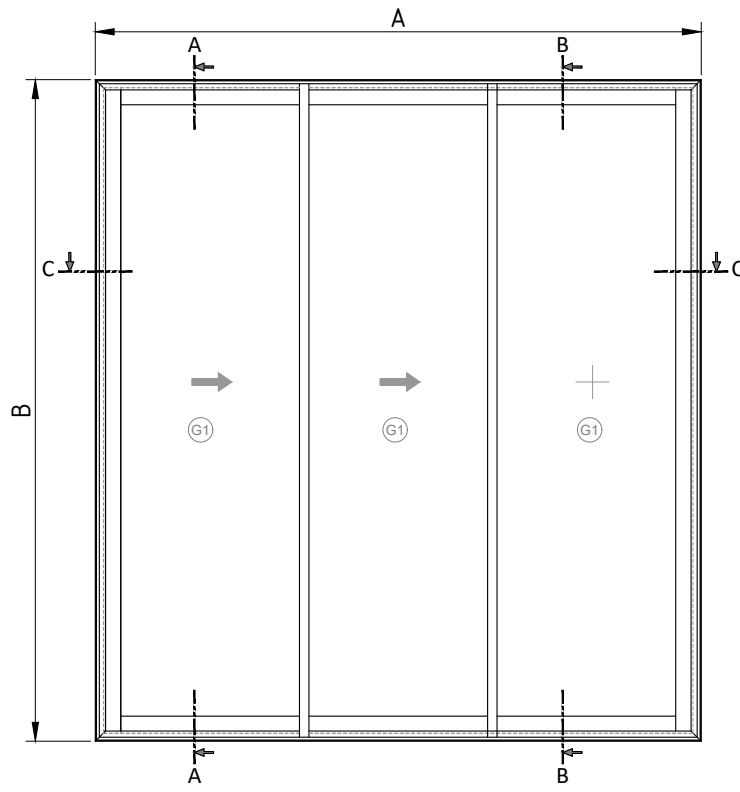

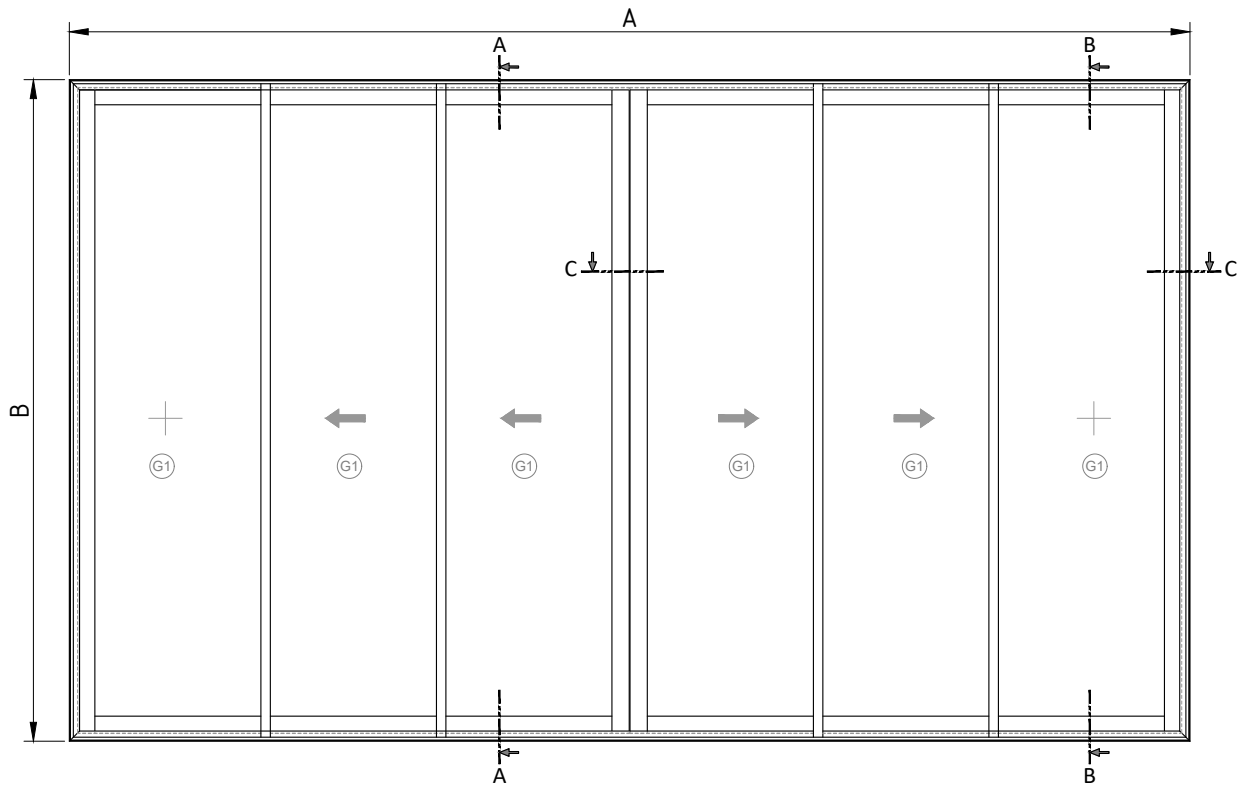

MATERIAL LIST				
Description	Part no.	Calculation	Qty.	Cut
Frame horizontal	B 061301	A= horizontal element dimension	2x	\-----/
Frame vertical	B 061301	B=vertical element dimension	2x	\-----/
Vent horizontal		$V_{A1} = (A/6) + 21.7$		
Vent horizontal		$V_{A2} = (A/6) - 5.1$		
Vent vertical		$V_B = B - 59.2$		
Vent profile horizontal	B 061304	$A_{H1} = (A/6) - 23.6$	8x	-----
Vent profile horizontal	B 061304	$A_{H2} = (A/6) - 8.1$	4x	-----
Vent Vertical (lock side)	B 061307	$B_V = B - 62.2$	2x	-----
Vent Vertical	B 061303	$B_V = B - 62.2$	2x	-----
Vent Vertical (labyrinth side)	P 061108	$B_V = B - 62.2$	4x	-----
Vent Vertical (labyrinth side structural)	P 061111	$B_V = B - 62.2$	4x	-----
Running Rail (Track) for 50Kg Roller	P 061112			
Running Rail (Track) for 120Kg & 200Kg Roller	P 061140	$= A - 73.2$	2x	-----
Outer Frame Corner Cleat	P 499605	$Z061505 = 39.7\text{mm}$	8x	-----
Mid Frame Corner Cleat	P 499605	$Z061507 = 26.5\text{mm}$	4x	-----
Fly screen corner cleat	P 599343	$Z663033 = 11.1\text{mm}$	8x	-----
Fly Screen Shutter - Horizontal	P 660055	$S_H = V_A$	4x	\-----/
Fly Screen Shutter - Vertical	P 660055	$S_V = B - 62$	4x	\-----/
Fix sash support	P 061107	$= Z 061508 (60\text{mm long piece})$	4x	-----
meeting profile	P 061107	$= B_{V1} - 20$	1x	-----
Operating Rod	H 062007	$= V_B - 600$	1x	-----
PVC Interlock profile (for active sash)	K 061001	$p1 = B_{V1}$	8x	-----
Glass - G1		$G_{H1} = ((A/6) - 48.3), G_{V1} = (B - 158)$	6x	-

MATERIAL LIST				
Description	Part no.	Calculation	Qty.	Cut
U - Shape Gasket	see glazing table	$= (G_{H1} + G_{V1}) \times 12$	LM	-
Interlocking Gasket	Z 061815	$= p1 \times 8$	LM	-
Weather Strip For Shutter	Z 061812	$= (V_A + V_B) \times 24$	LM	-
Weather Strip For Fly Screen	Z 061812	$= (S_H + S_V) \times 4$	LM	-
PVC Gasket For Fly Screen	Z 918565	$= ((S_H - 70) + (S_V - 70)) \times 4$	LM	-
Center Seal piece	Z 061801	-	8x	-
Nail plastic	Z 918385	stop buffer & labyrinth cover assembly	18x	-
Cover, Lock Side	Z 061502	-	8x	-
Cover, Labyrinth	Z 061503	-	16x	-
Roller For Fly Screen	Z 018711	-	4x	-
Handle For Fly Screen	Z 669049	-	2x	-
Sliding Bumper	Z 060521	-	4x	-
Stop buffer	Z 060800	-	6x	-
Anti Lift Device	Z 993546	-	12x	-
Screw b4.2 x 40 DIN 7982	Z913239	sash assembly (lock side vent)	16x	-
Screw b4.2 x 22 DIN 7982	Z901499	sash assembly (labyrinth vent)	32x	-
Screw b3.5 x 16 DIN 7504 SO	Z911050	fly screen roller assembly	8x	-
Screw b3.9 x 16 DIN 7981	Z900235	fix sash support fixing	16x	-
Screw b3.9 x 19 DIN 7982	Z900656	fix sash fixing	4x	-
Screw b4.2 x 40 DIN 7982	Z913239	$= BV / 300$	-	-

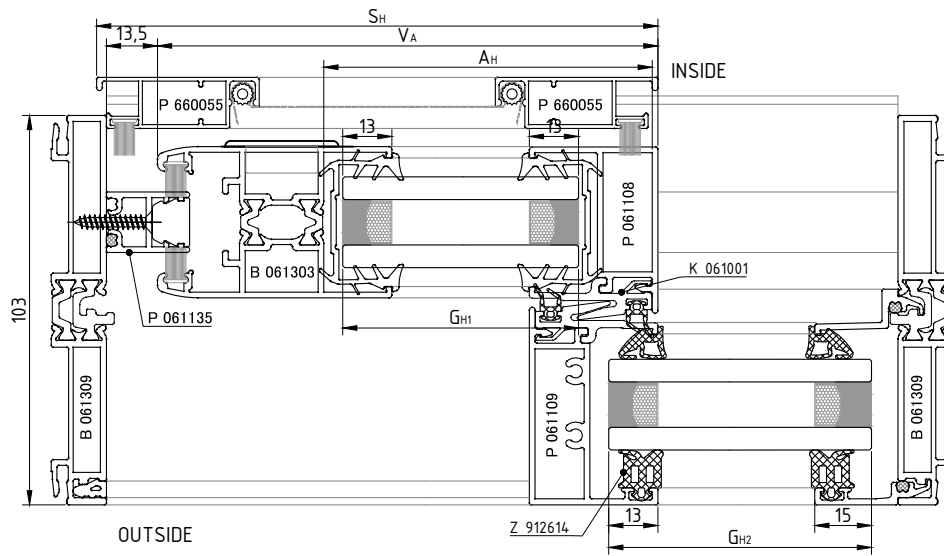

PLAN C-C

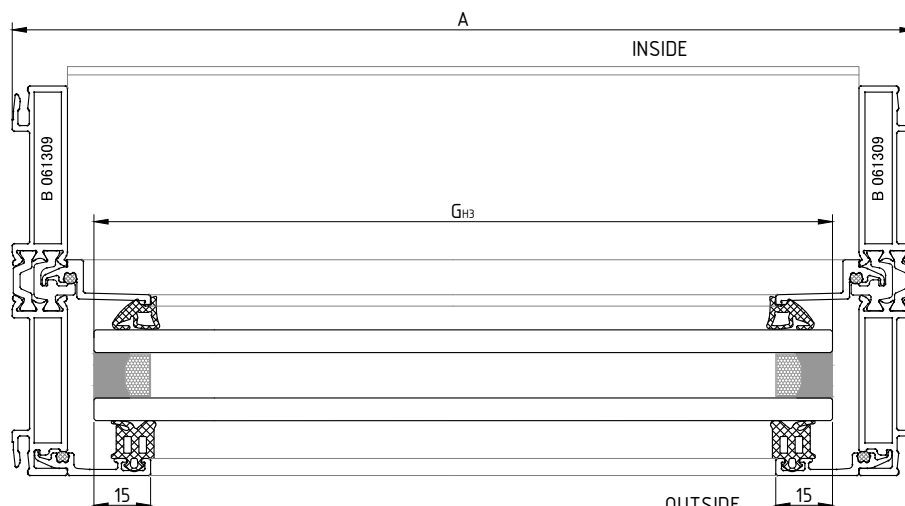

G_{H1} , G_{H2} , G_{H3} , G_{H4} = see glass dimension

PLAN D-D

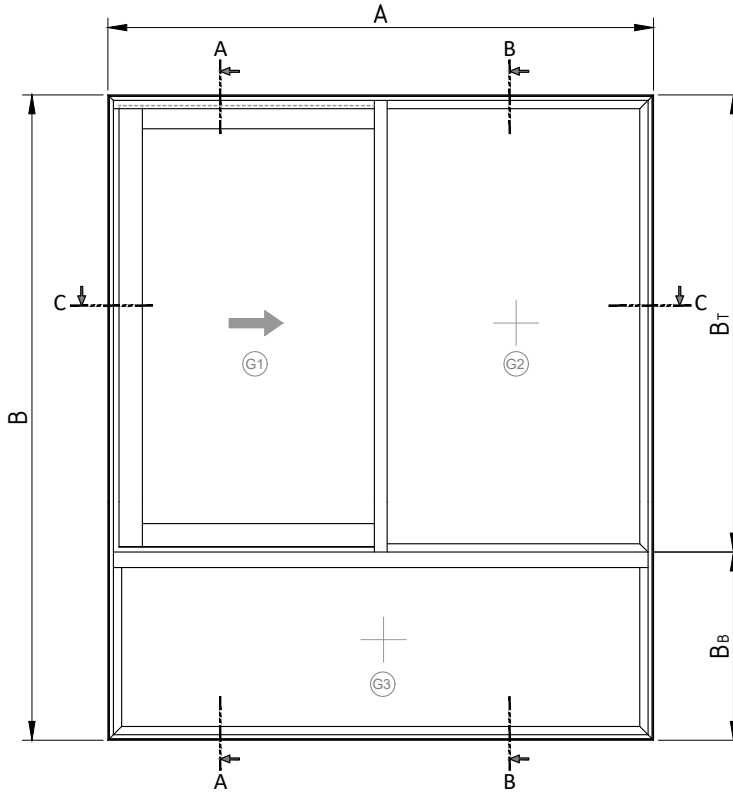

MATERIAL LIST				
Description	Part no.	Calculation	Qty.	Cut
Frame horizontal	B 061309	A= horizontal element dimension	2x	\\-\\-\\-\\-
Frame vertical	B 061309	B=vertical element dimension	2x	\\-\\-\\-\\-
Vent horizontal		$V_A = (A/2) - 11.1$		
Vent vertical		$V_B = B - 44.6$		
Vent profile horizontal	B 061304	$A_H = (A/2) - 56.6$	2x	\\-\\-\\-\\-
Vent Vertical (lock side)	B 061303	$B_{V1} = B - 47.6$	1x	\\-\\-\\-\\-
Mid transom (window)	B 061311	$T = A - 29.2$	1x	\\-\\-\\-\\-
Vent Vertical (labyrinth side)	P 061108	$B_{V2} = B - 47.6$	1x	\\-\\-\\-\\-
Fix frame vertical (monorail)	P 061109	$B_{V3} = B - 14.6$	1x	\\-\\-\\-\\-
Running Rail (Track)	P 061112	$= A - 51.2$	1x	\\-\\-\\-\\-
Rail adaptor profile	P 061135	$= B - 58.6$	1x	\\-\\-\\-\\-
Rail adaptor profile	P 061135	$= A - 29.2$	1x	\\-\\-\\-\\-
Beading - center vertical	P 061122	$dc1 = B - 1.2$	1x	\\-\\-\\-\\-
Beading - center horizontal	P 061122	$dc2 = (A/2) - 24.9$	2x	\\-\\-\\-\\-
Beading - center horizontal (fix field)	P 061122	$dc3 = A - 15.8$	2x	\\-\\-\\-\\-
Beading - center vertical (fix field)	P 061122	$dc4 = B - 20.4$	2x	\\-\\-\\-\\-
Beading - outer vertical	P 061123	$de1 = B + 2.8$	1x	\\-\\-\\-\\-
Beading - outer horizontal	P 061123	$de2 = (A/2) - 22.9$	2x	\\-\\-\\-\\-
Beading - outer horizontal (fix field)	P 061123	$de3 = A - 12$	1x	\\-\\-\\-\\-
Beading - outer vertical (fix field)	P 061123	$de4 = B - 47.1$	2x	\\-\\-\\-\\-
Top barrier profile	P 061136	$dt1 = (A/2) - 31.6$	1x	\\-\\-\\-\\-
Outer Frame Corner Cleat	P 499605	Z061505= 39.7mm	4x	\\-\\-\\-\\-
Outer Frame Corner Cleat	P 499605	Z061506= 32.7mm	4x	\\-\\-\\-\\-
Fly screen corner cleat	P 599343	Z663033= 11.1mm	4x	\\-\\-\\-\\-
Fly Screen Shutter - Horizontal	P 660055	$S_H = (A/2) + 5$	2x	\\-\\-\\-\\-
Fly Screen Shutter - Vertical	P 660055	$S_V = B - 47.6$	2x	\\-\\-\\-\\-
Fly Screen Track - Horizontal	P 061138	$= A - 8.5$	2x	\\-\\-\\-\\-
PVC Interlock profile (for active sash)	K 061001	$pi1 = B_{V1}$	1x	\\-\\-\\-\\-
PVC Interlock profile (for monorail)	K 061001	$pi2 = B - 58.6$	1x	\\-\\-\\-\\-

MATERIAL LIST				
Description	Part no.	Calculation	Qty.	Cut
Glass - G1		$G_{H1} = ((A/2) - 81)$, $G_{V1} = (B - 143.5)$	1x	-
Glass - G2		$G_{H2} = ((A/2) - 25.7)$, $G_{V2} = (B - 28.6)$	1x	-
Glass - G3		$G_{H3} = (A - 43)$, $G_{V3} = (B - 47.8)$	1x	-
U - Shape Gasket		$= (G_{H1} + G_{V1}) \times 2$	LM	-
External glazing Gasket		$= (G_{H2} + G_{V2} + G_{H3} + G_{V3}) \times 2$	LM	-
Internal push Gasket		$= (G_{H2} + G_{V2} + G_{H3} + G_{V3}) \times 2$	LM	-
Interlocking Gasket	Z 061815	$= pi1 + pi2$	LM	-
Weather Strip For Shutter	Z 061812	$= (V_A + V_B) \times 4$	LM	-
Weather Strip For Fly Screen	Z 061812	$= (S_H + S_V) \times 2$	LM	-
PVC Gasket For Fly Screen	Z 918565	$= ((S_H - 70) + (S_V - 70)) \times 2$	LM	-
Seal Gasket For Outer Frame	Z 061807	$= ((A/2) - 22) \times 2 + ((B - 14.6) \times 1)$	LM	-
Monorail frame bottom cover gasket	Z 061806	$= dt1$	LM	-
Sealing Cord For Beading	Z 902161	$= dc1 + 2 + 3 + 4 + de1 + 2 + 3 + 4 + dt1$	LM	-
Center Seal piece (L+R)	Z 061810	-	1x	-
Nail plastic	Z 918385	stop buffer & labyrinth cover assembly	4x	-
Cover, Lock Side	Z 061502	-	2x	-
Cover, Labyrinth	Z 061503	-	2x	-
Drainage Cap	Z 918505	-	4x	-
Roller For Fly Screen	Z 018711	-	2x	-
Handle For Fly Screen	Z 669049	-	2x	-
Sliding Bumper	Z 060521	-	1x	-
Stop Buffer	Z 060800	-	2x	-
Anti Lift Device	Z 993546	-	2x	-
Screw b4.2 x 40 DIN 7982	Z913239	sash assembly (lock side vent)	4x	-
Screw b4.2 x 22 DIN 7982	Z901499	sash assembly (labyrinth vent)	4x	-
Screw b4.2 x 22 DIN 7982	Z901499	Fix frame vertical assembly (monorail)	4x	-
Screw b4.8 x 32 DIN 7982	Z906602	mid transom assembly	8x	-
Screw b3.5 x 16 DIN 7504 SO	Z911050	fly screen roller assembly, top barrier	7x	-
Screw b3.9 x 19 DIN 7982	Z900656	rail adaptor profile assembly = $B_{V1} / 300$	-	-

Processing

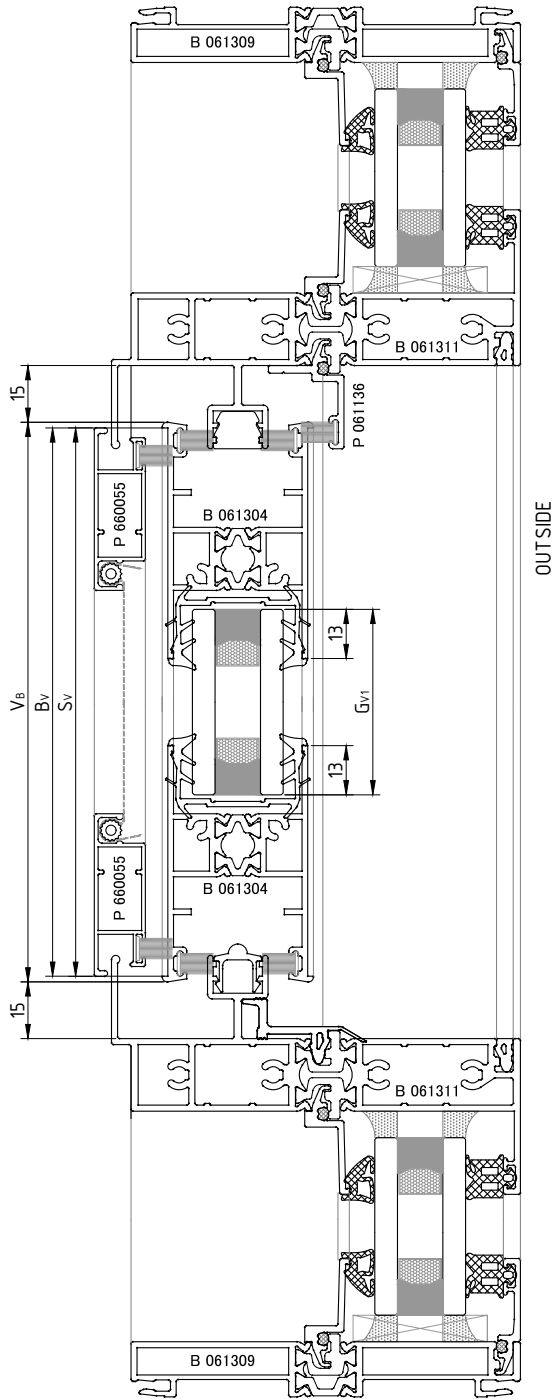

SECTION A-A

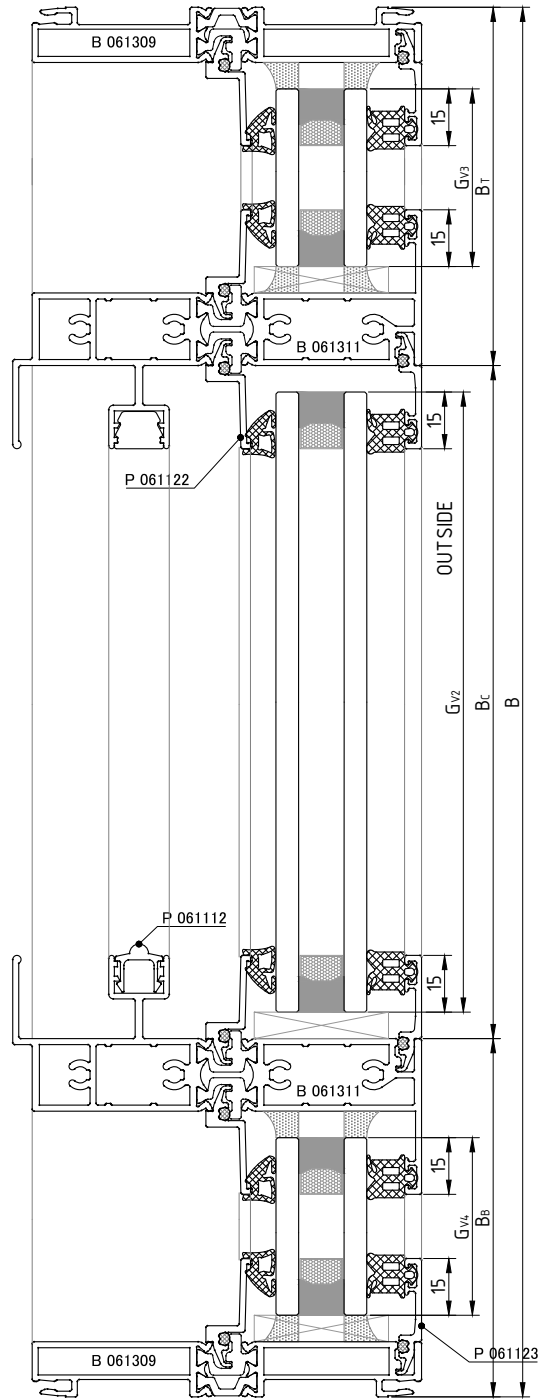

SECTION B-B

Gv1, Gv2, Gv3, Gv4 = see glass dimension

Processing

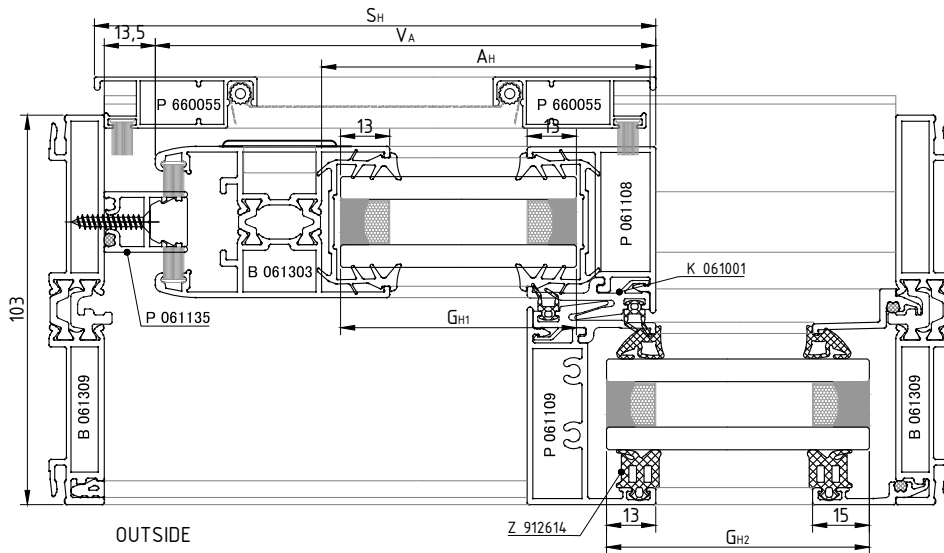

PLAN C-C

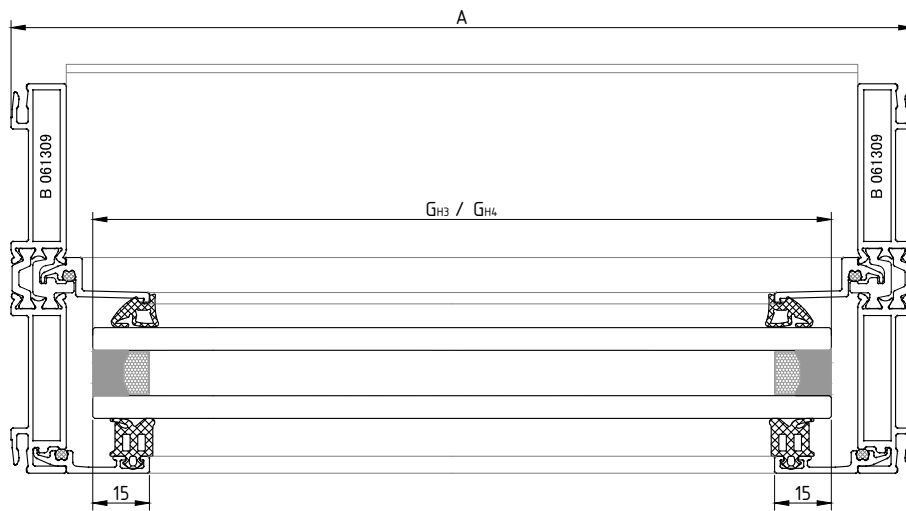

G_{H1}, G_{H2}, G_{H3}, G_{H4} = see glass dimension

PLAN D-D

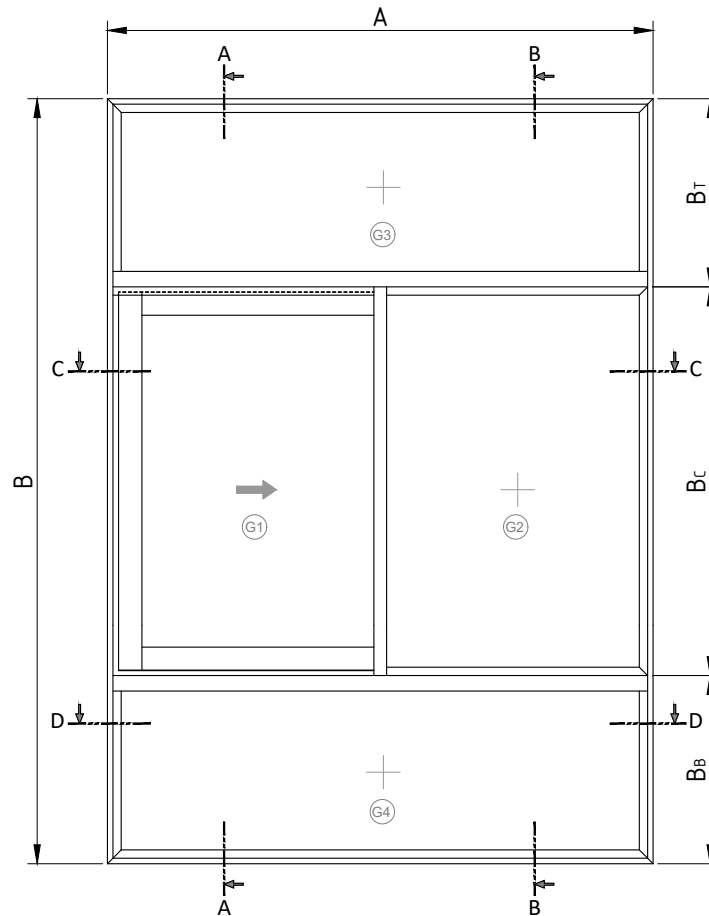

MATERIAL LIST				
Description	Part no.	Calculation	Qty.	Cut
Frame horizontal	B 061309	A= horizontal element dimension	2x	\\-\\-\\-\\-
Frame vertical	B 061309	B=vertical element dimension	2x	\\-\\-\\-\\-
Vent horizontal		$V_A = (A/2) - 11.1$		
Vent vertical		$V_B = B_c - 30$		
Vent profile horizontal	B 061304	$A_H = (A/2) - 56.6$	2x	----
Vent Vertical (lock side)	B 061303	$B_{V1} = B_c - 33$	1x	----
Mid transom (window)	B 061311	$T = A - 29.2$	2x	----
Vent Vertical (labyrinth side)	P 061108	$B_{V2} = B_c - 33$	1x	----
Fix frame vertical (monorail)	P 061109	$B_{V3} = B_c$	1x	----
Running Rail (Track)	P 061112	$= A - 51.2$	1x	----
Rail adaptor profile	P 061135	$= B_c - 44$	1x	----
Beading - center vertical	P 061122	$dc1 = B_c + 13$	1x	\\-\\-\\-\\-
Beading - center horizontal	P 061122	$dc2 = (A/2) - 24.9$	2x	\\-\\-\\-\\-
Beading - center horizontal (fix field)	P 061122	$dc3 = A - 15.8$	4x	\\-\\-\\-\\-
Beading - center vertical (fix field top)	P 061122	$dc4 = B_r - 20.4$	2x	\\-\\-\\-\\-
Beading - center vertical (fix field bottom)	P 061122	$dc5 = B_b - 20.4$	2x	\\-\\-\\-\\-
Beading - outer vertical	P 061123	$de1 = B + 17.4$	1x	\\-\\-\\-\\-
Beading - outer horizontal	P 061123	$de2 = (A/2) - 22.9$	2x	---
Beading - outer horizontal (fix field)	P 061123	$de3 = A - 12$	2x	\\-\\-\\-\\-
Beading - outer vertical (fix field top)	P 061123	$de4 = B_r - 47.1$	2x	\\-\\-\\-\\-
Beading - outer vertical (fix field bottom)	P 061123	$de5 = B_b - 47.1$	2x	\\-\\-\\-\\-
Top barrier profile	P 061136	$dt1 = (A/2) - 31.6$	1x	----
Outer Frame Corner Cleat	P 499605	$Z061505 = 39.7mm$	4x	----
Outer Frame Corner Cleat	P 499605	$Z061506 = 32.7mm$	4x	----
Fly screen corner cleat	P 599343	$Z663033 = 11.1mm$	4x	----
Fly Screen Shutter - Horizontal	P 660055	$S_H = (A/2) + 5$	2x	\\-\\-\\-\\-
Fly Screen Shutter - Vertical	P 660055	$S_V = B_c - 33$	2x	\\-\\-\\-\\-
Fly Screen Track - Horizontal	P 061138	$= A - 8.5$	2x	----
PVC Interlock profile (for active sash)	K 061001	$pi1 = B_{V1}$	1x	----
PVC Interlock profile (for monorail)	K 061001	$pi2 = B_c - 44$	1x	----

MATERIAL LIST				
Description	Part no.	Calculation	Qty.	Cut
Glass - G1		$G_{H1} = ((A/2) - 81)$, $G_{V1} = (B_c - 129)$	1x	-
Glass - G2		$G_{H2} = ((A/2) - 25.7)$, $G_{V2} = (B_c - 14)$	1x	-
Glass - G3		$G_{H3} = (A - 43)$, $G_{V3} = (B_r - 47.8)$	1x	-
Glass - G4		$G_{H4} = (A - 43)$, $G_{V4} = (B_b - 47.8)$	1x	-
U - Shape Gasket	see glazing table	$= (G_{H1} + G_{V1}) \times 2$	LM	-
External glazing Gasket		$= (G_{H2} + G_{V2} + G_{H3} + G_{V3} + G_{H4} + G_{V4}) \times 2$	LM	-
Internal push Gasket		$= (G_{H2} + G_{V2} + G_{H3} + G_{V3} + G_{H4} + G_{V4}) \times 2$	LM	-
Interlocking Gasket	Z 061815	$= pi1 + pi2$	LM	-
Weather Strip For Shutter	Z 061812	$= (V_A + V_B) \times 4$	LM	-
Weather Strip For Fly Screen	Z 061812	$= (S_H + S_V) \times 2$	LM	-
PVC Gasket For Fly Screen	Z 918565	$= ((S_H - 70) + (S_V - 70)) \times 2$	LM	-
Seal Gasket For Outer Frame	Z 061807	$= ((A/2) - 22) \times 2 + ((B_c + 18) \times 1)$	LM	-
Monorail frame bottom cover gasket	Z 061806	$= dt1$	LM	-
Sealing Cord For Beading	Z 902161	$= dc1 + 2 + 3 + 4 + 5 + de1 + 2 + 3 + 4 + 5 + dt1$	LM	-
Center Seal piece (L+R)	Z 061810	-	1x	-
Nail plastic	Z 918385	stop buffer & labyrinth cover assembly	4x	-
Cover, Lock Side	Z 061502	-	2x	-
Cover, Labyrinth	Z 061503	-	2x	-
Drainage Cap	Z 918505	-	6x	-
Roller For Fly Screen	Z 018711	-	2x	-
Handle For Fly Screen	Z 669049	-	2x	-
Sliding Bumper	Z 060521	-	1x	-
Stop Buffer	Z 060800	-	4x	-
Anti Lift Device	Z 993546	-	2x	-
Screw b4.2 x 40 DIN 7982	Z913239	sash assembly (lock side vent)	4x	-
Screw b4.2 x 22 DIN 7982	Z901499	sash assembly (labyrinth vent)	4x	-
Screw b4.2 x 22 DIN 7982	Z901499	Fix frame vertical assembly (monorail)	4x	-
Screw b4.8 x 32 DIN 7982	Z906602	mid transom assembly	16x	-
Screw b3.5 x 16 DIN 7504 SO	Z911050	fly screen roller assembly, top barrier	7x	-
Screw b3.9 x 19 DIN 7982	Z900656	rail adaptor profile assembly = $B_{V1} / 300$		-

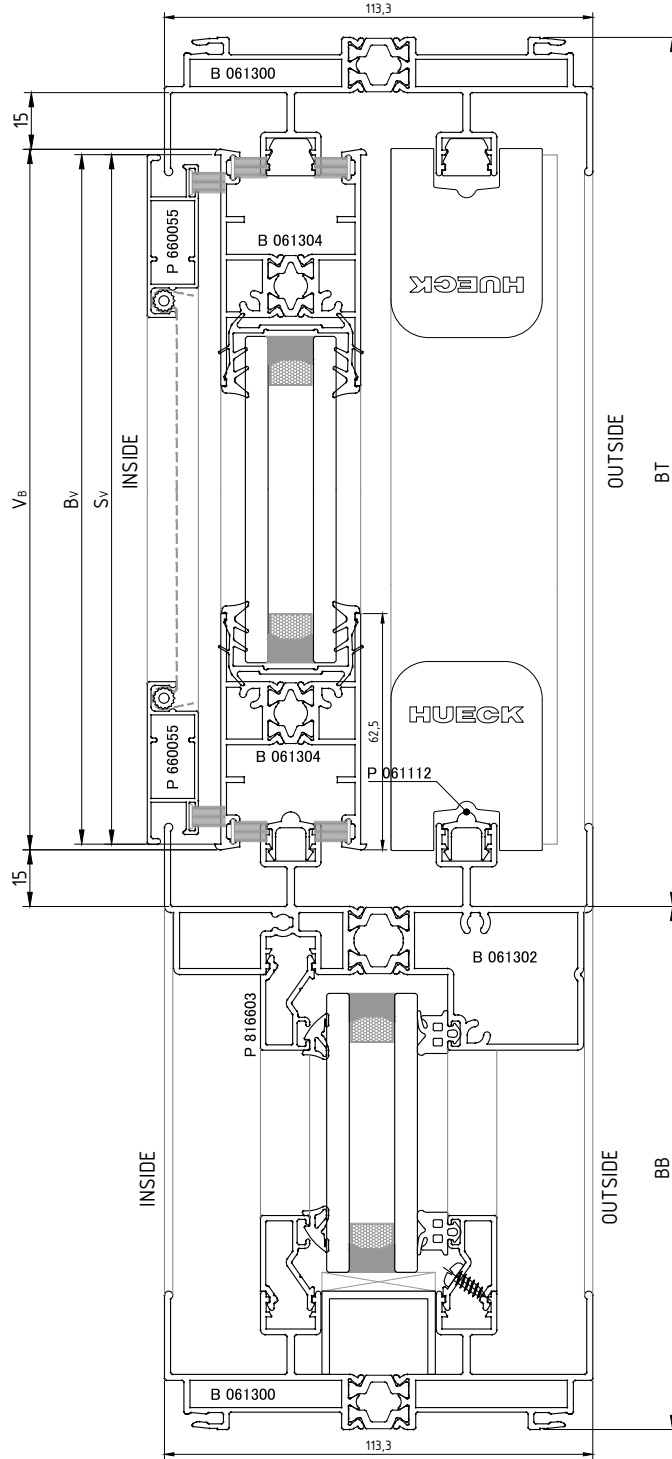

SECTION A-A

Processing

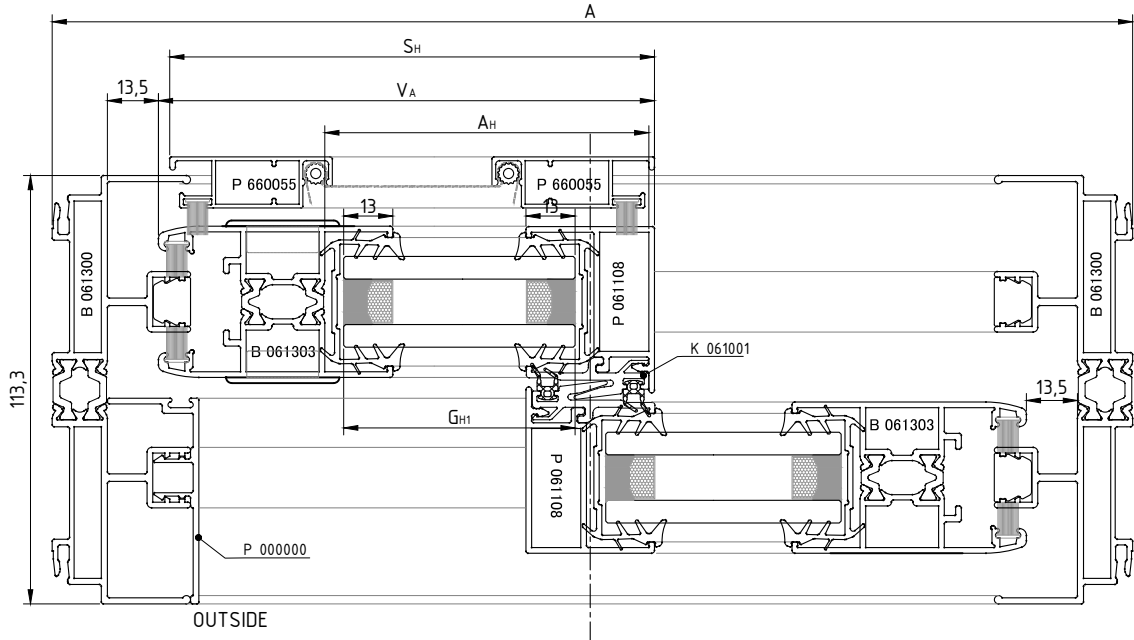

PLAN B-B



PLAN C-C

Processing

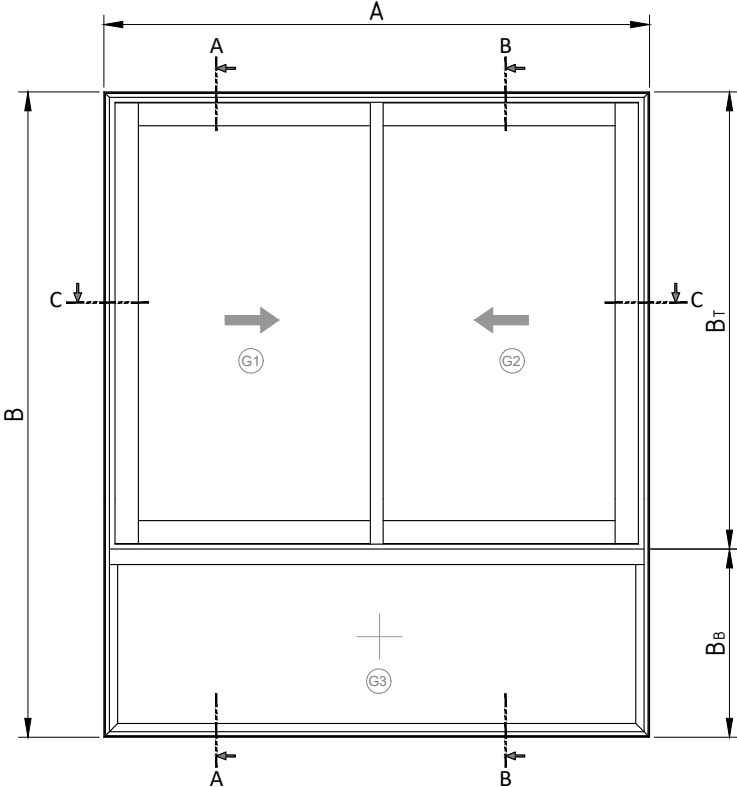

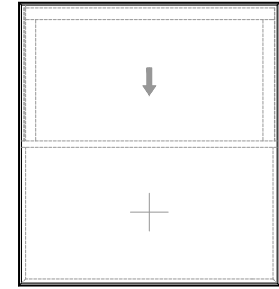

Drainage Scheme

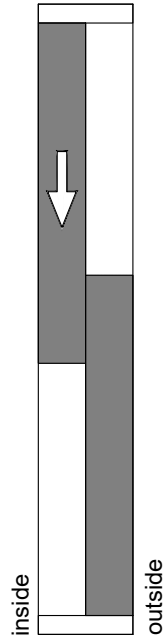

DRAIN SLOT	
(X)	25
(Y)	30
(Z)	30

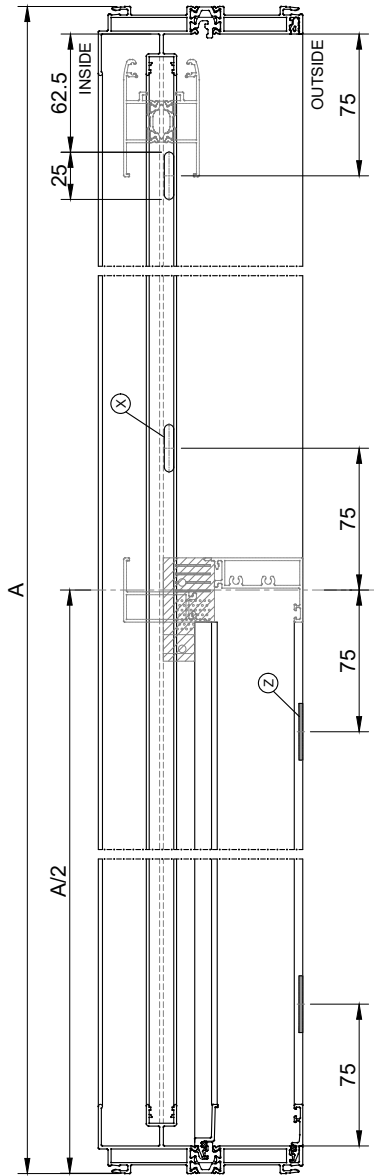

Processing frame

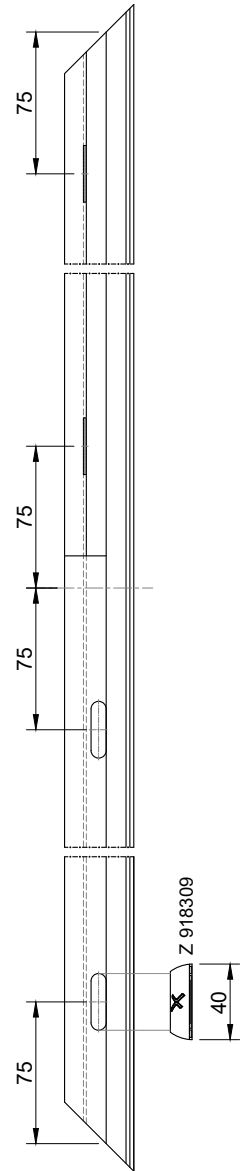
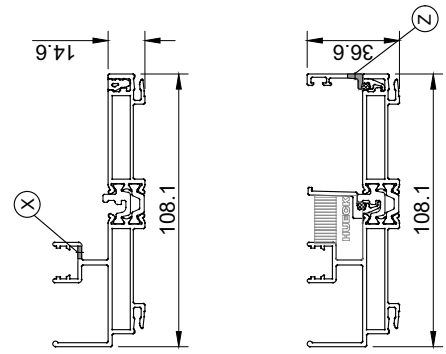

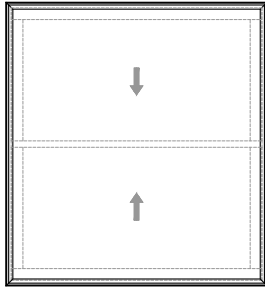

Drainage Scheme

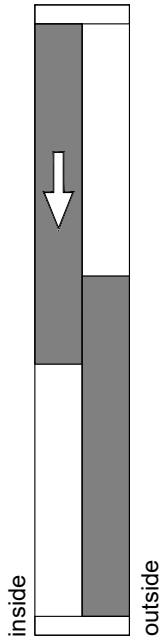

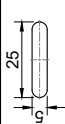
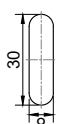
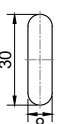
DRAIN SLOT	
(X)	
(Y)	
(Z)	

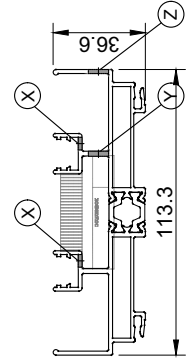
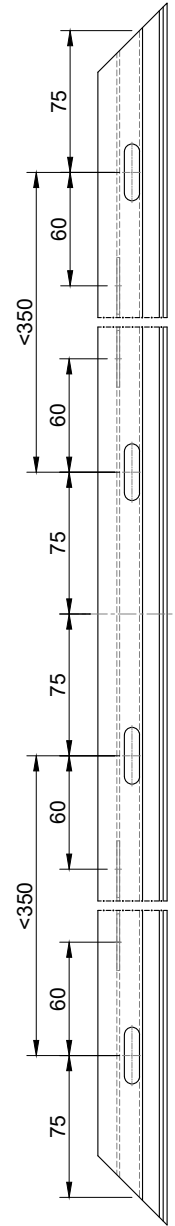
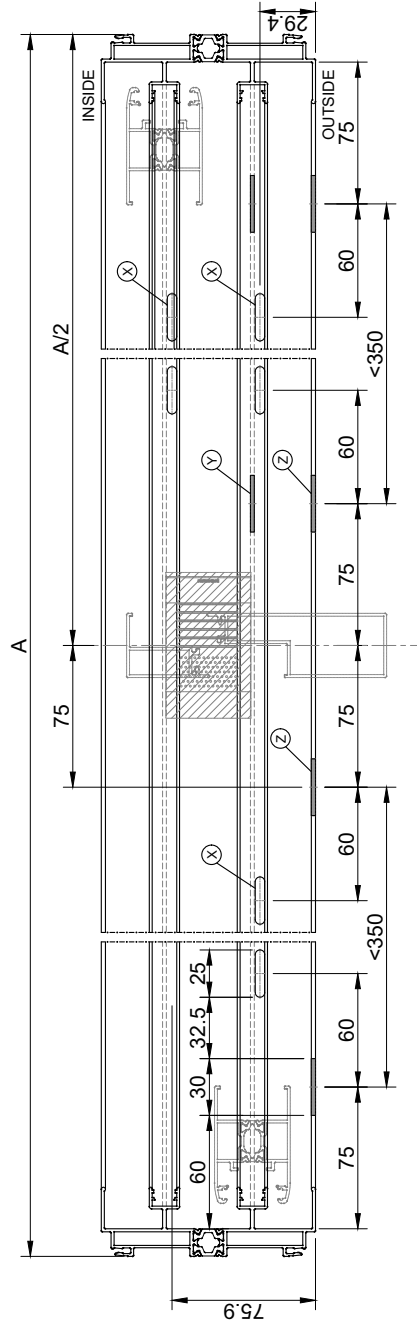

Drainage Scheme

DRAIN SLOT	
(X)	
(Y)	
(Z)	

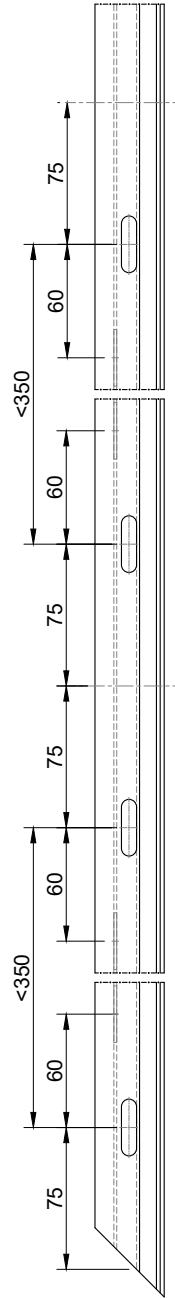
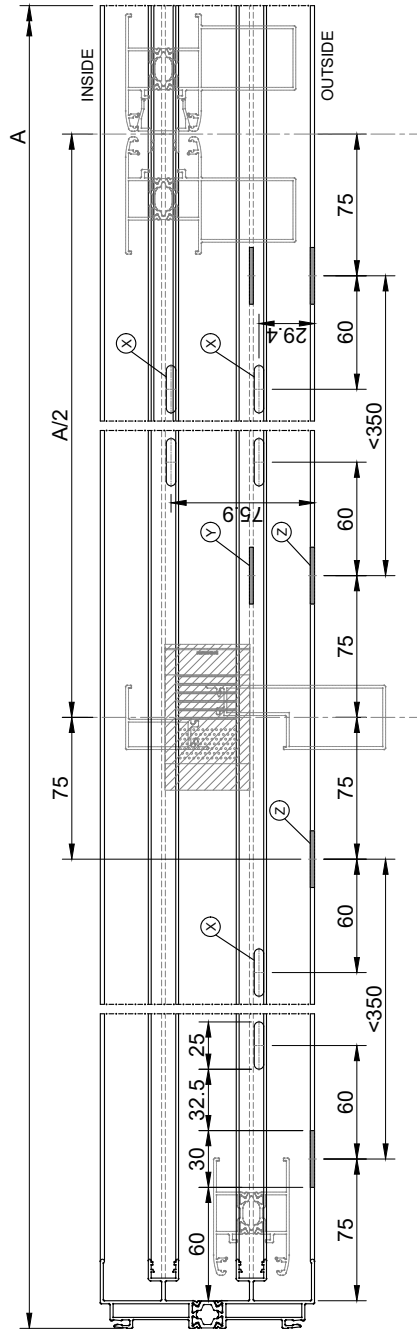
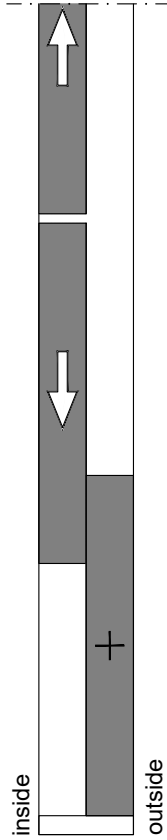
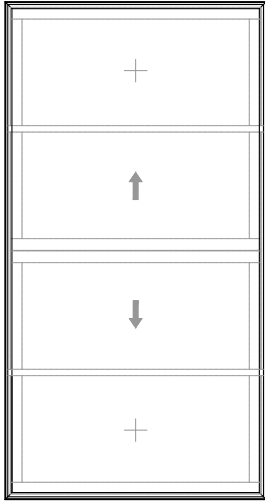

Processing frame

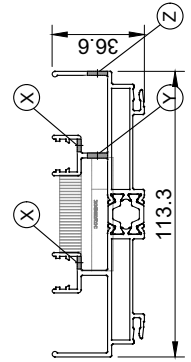

Drainage Scheme

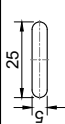
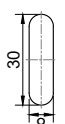
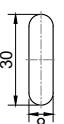
DRAIN SLOT	
(X)	
(Y)	
(Z)	

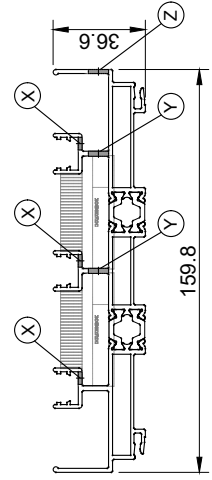
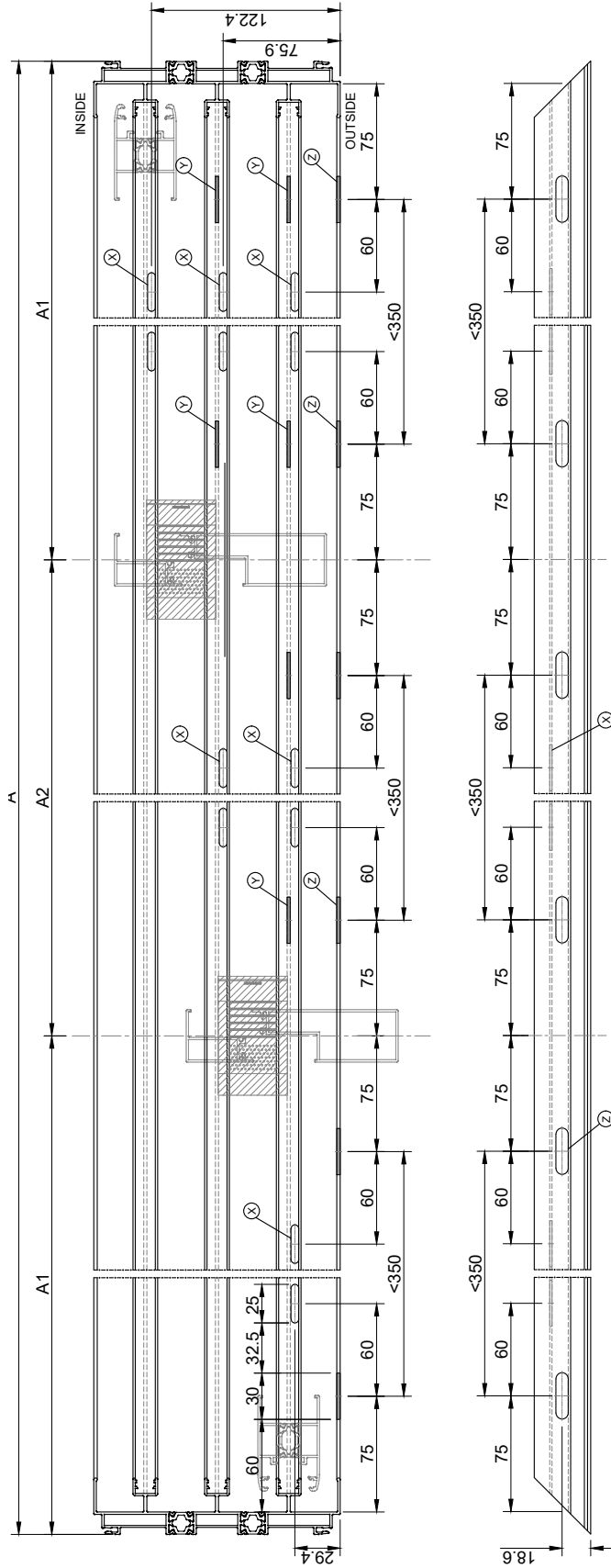
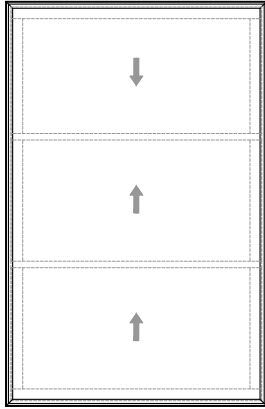
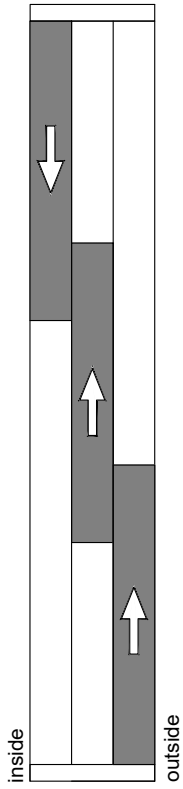

Drainage Scheme

DRAIN SLOT	
(X)	
(Y)	
(Z)	

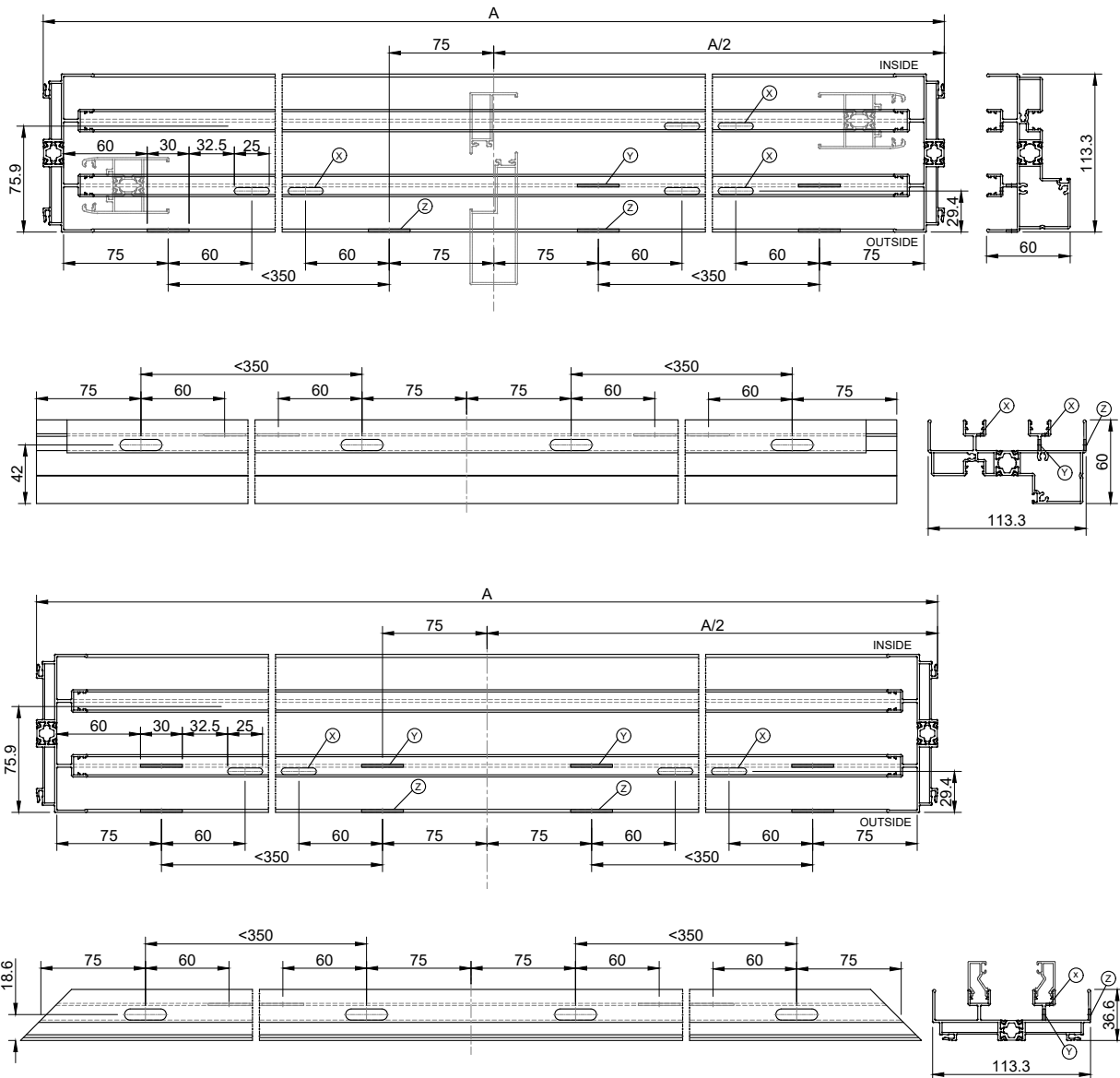
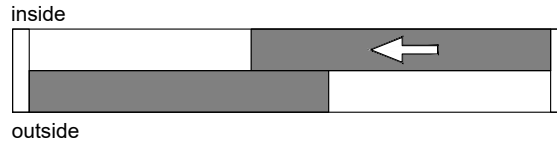
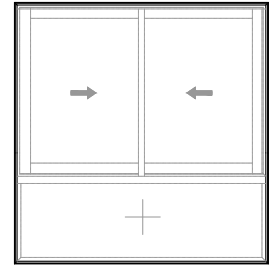

Processing

Drainage Scheme

DRAIN SLOT	
(X)	
(Y)	
(Z)	

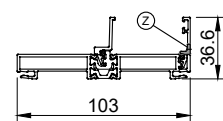
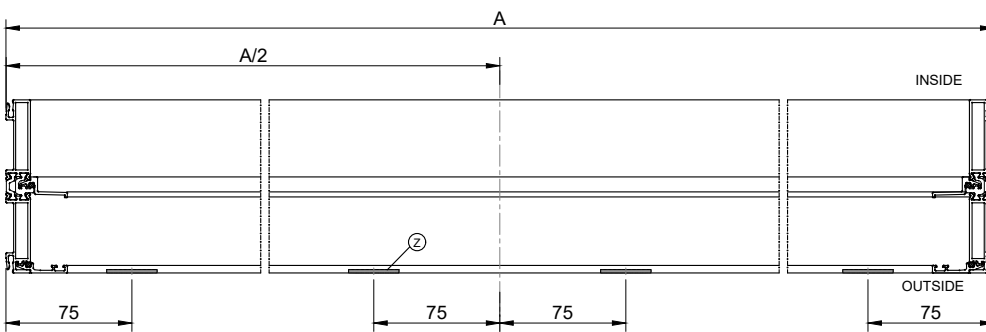
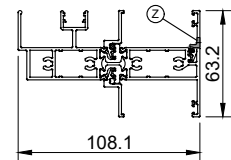
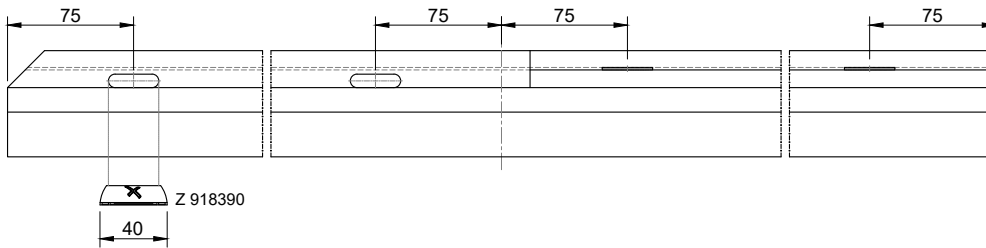
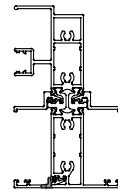
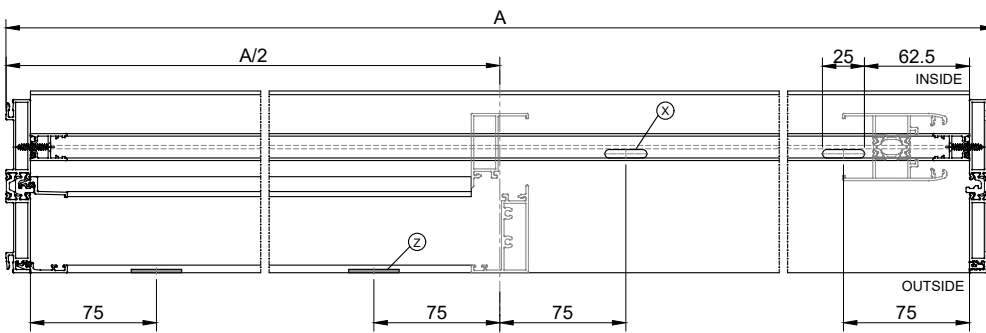
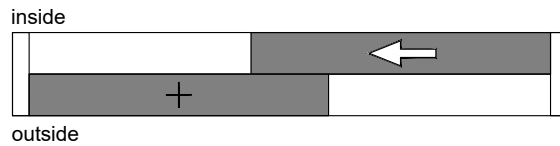
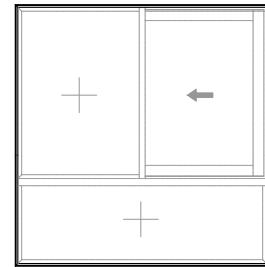

Processing

Corner brackets with pin

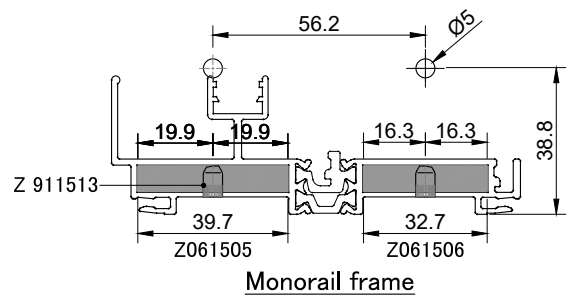
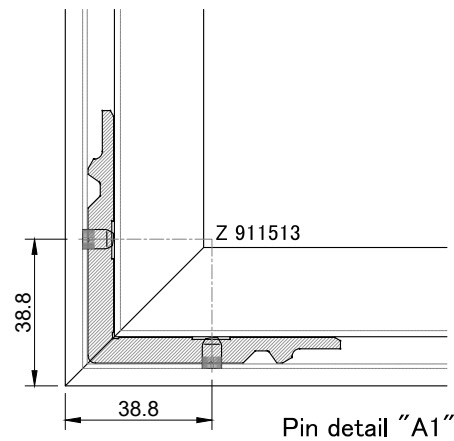
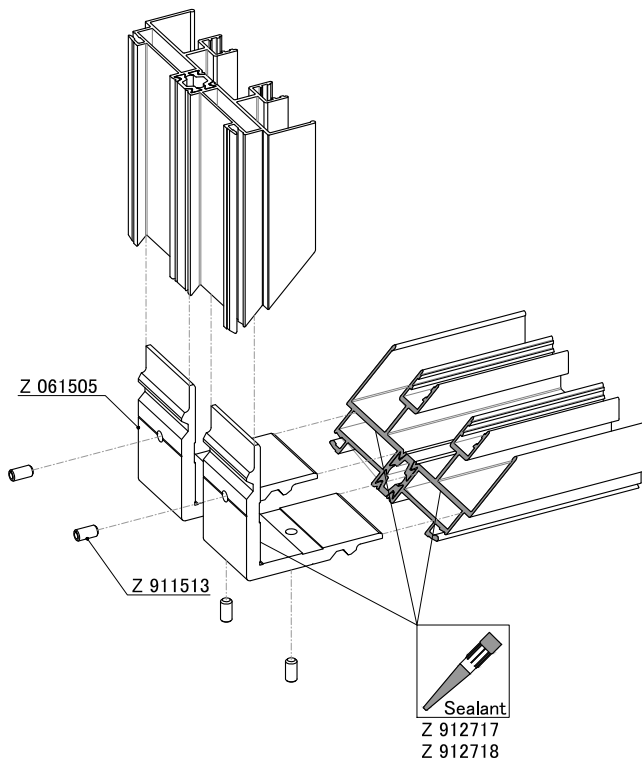
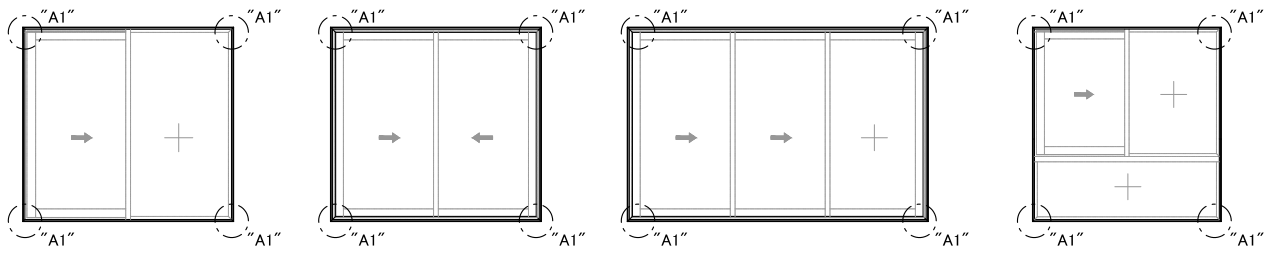

Monorail frame

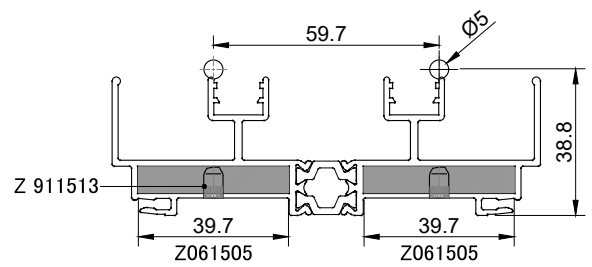
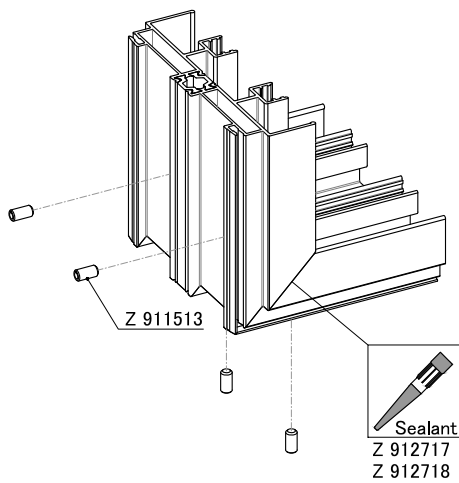

Two track frame

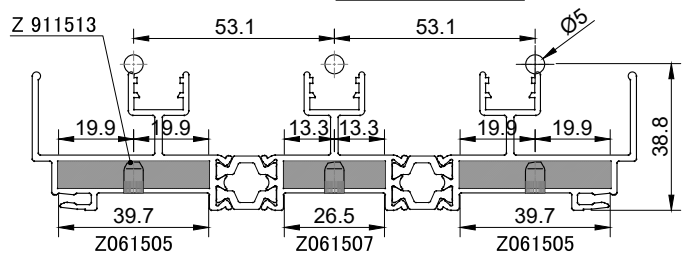

Three track frame

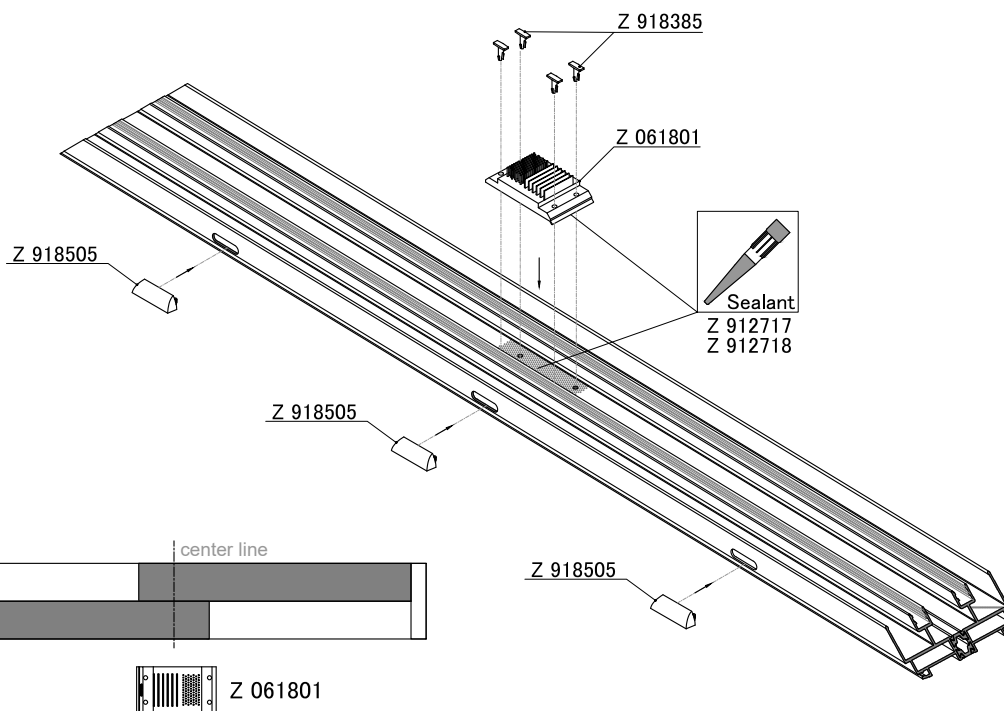
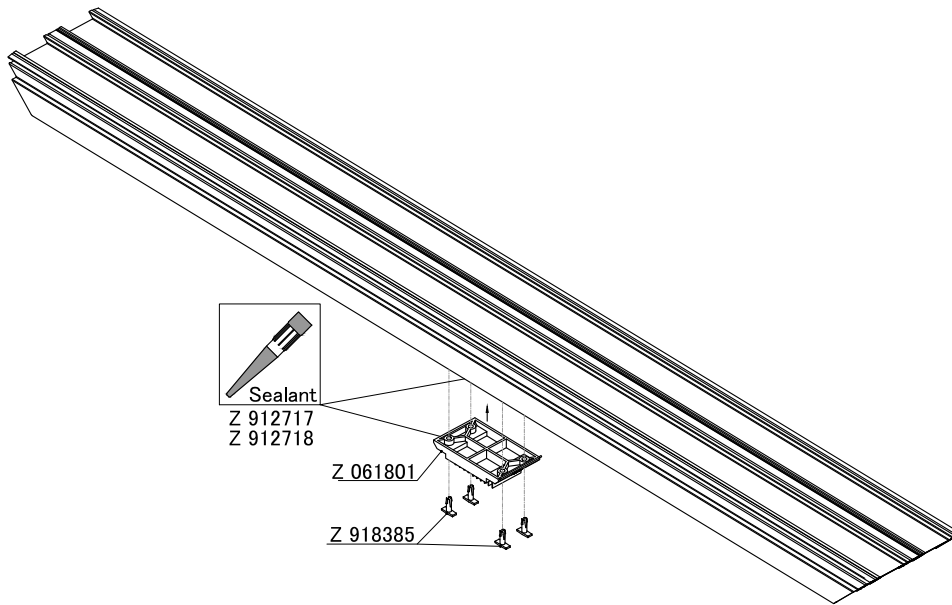
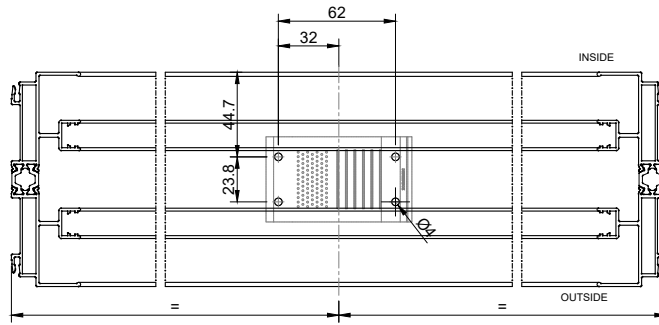

Processing

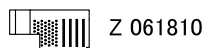
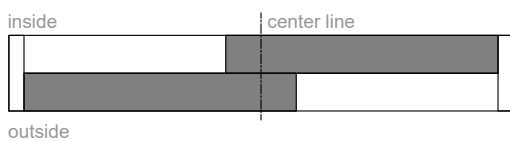
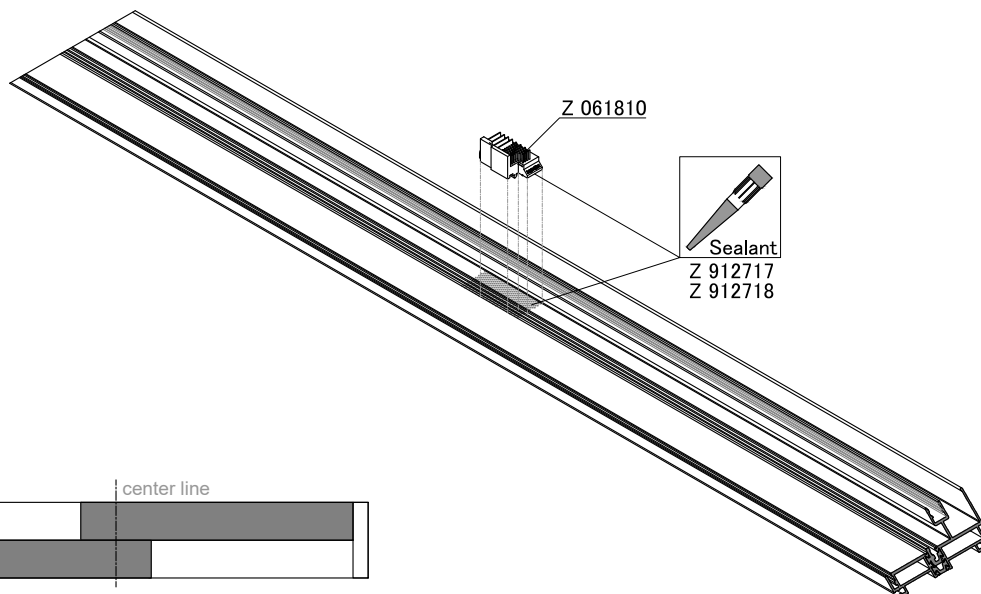
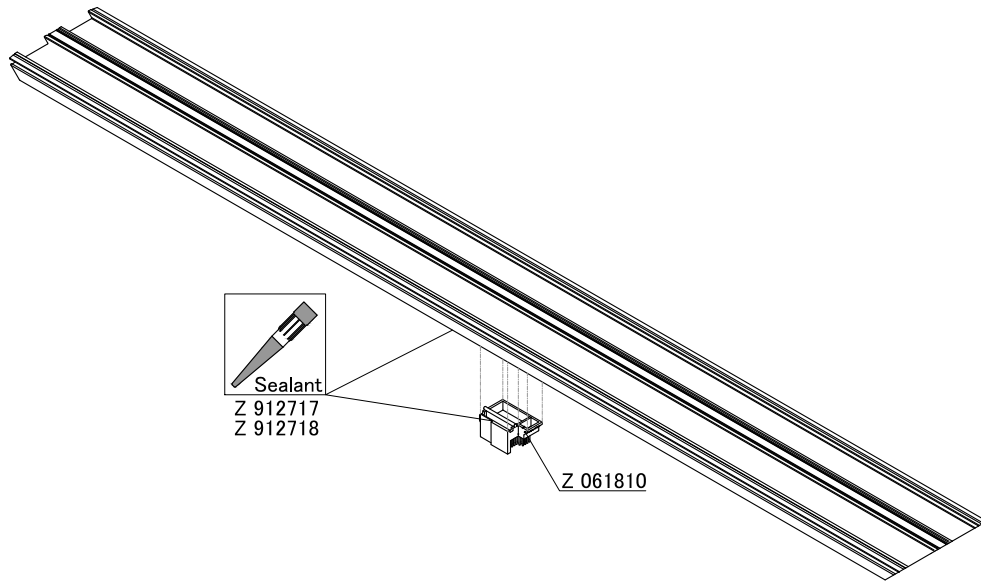
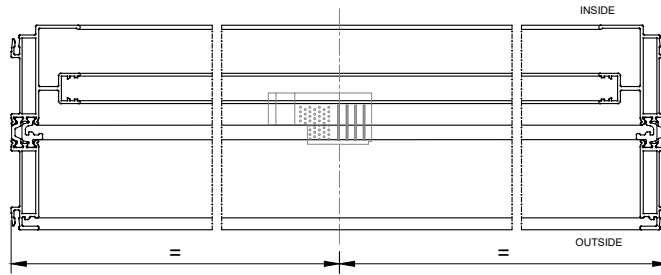

Monorail labyrinth fixation

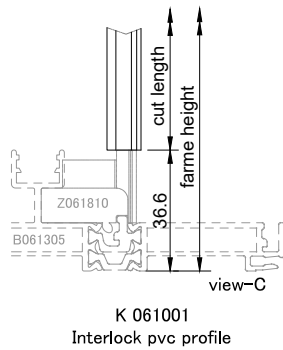
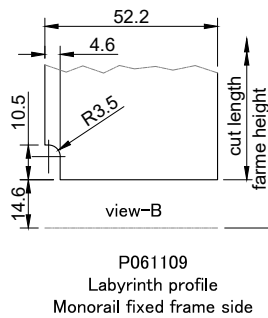
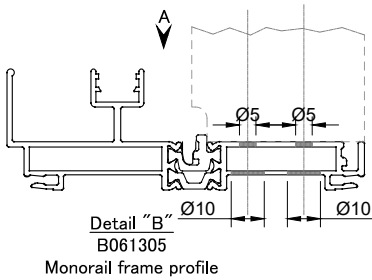
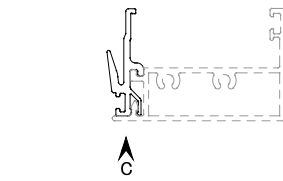
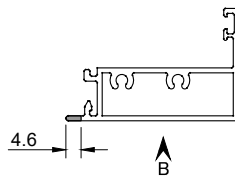
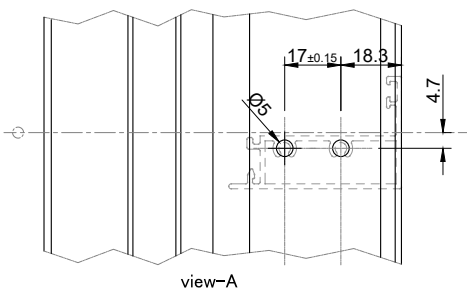
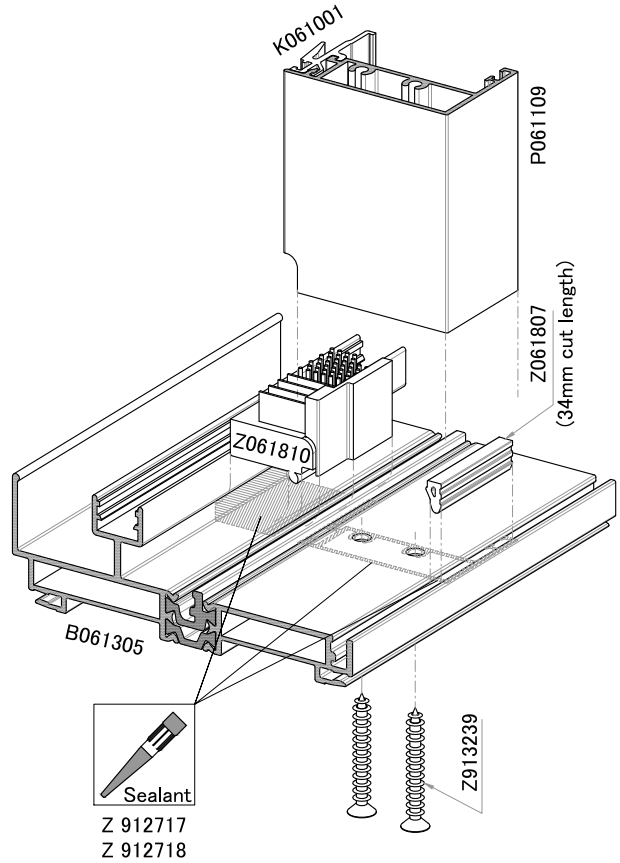
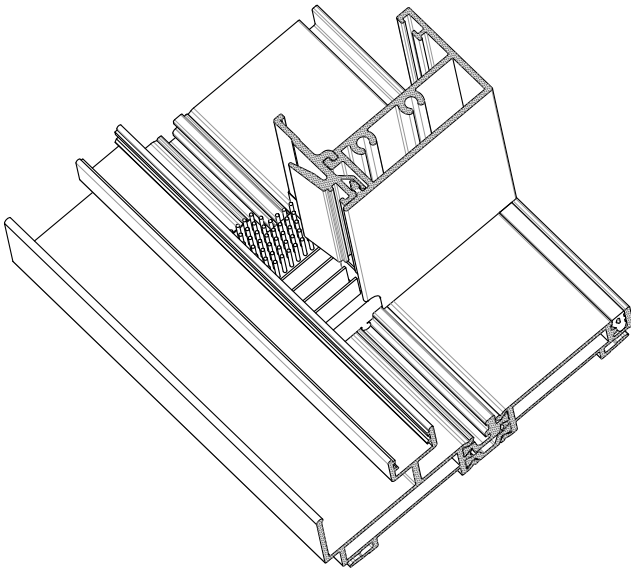
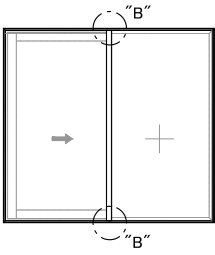

Monorail frame profile

P061109
Labyrinth profile
Monorail fixed frame side

K 061001
Interlock pvc profile

Intermediate transom fixation

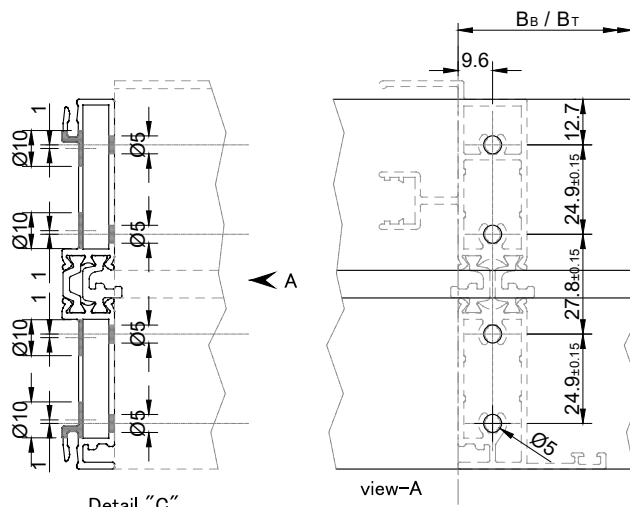
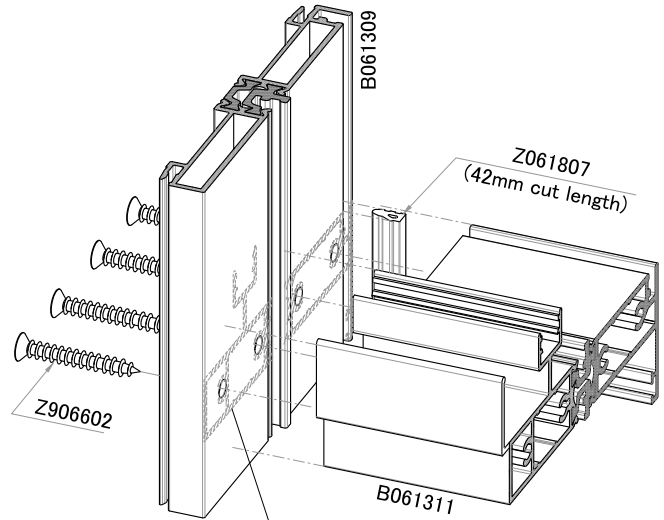
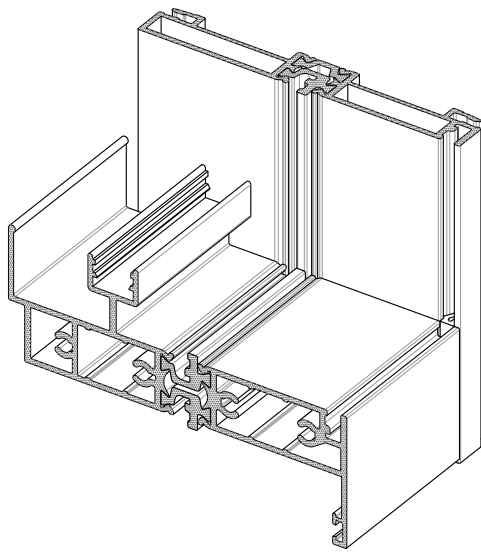
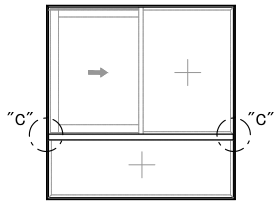

Detail "C"
B061309
Monorail frame profile

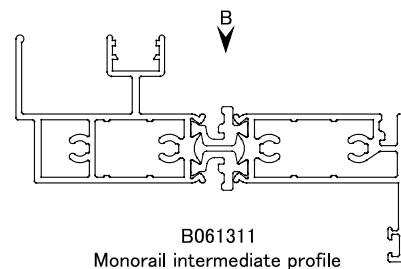
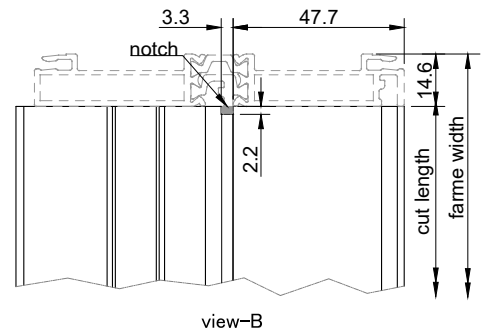

B061311
Monorail intermediate profile

Processing

Intermediate transom fixation

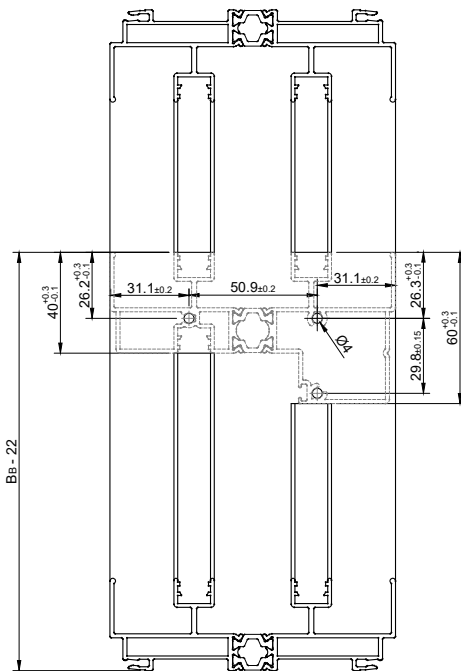
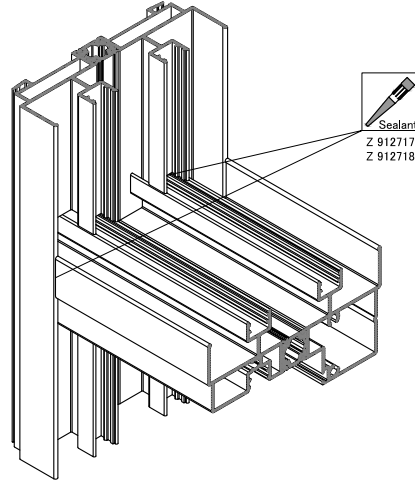
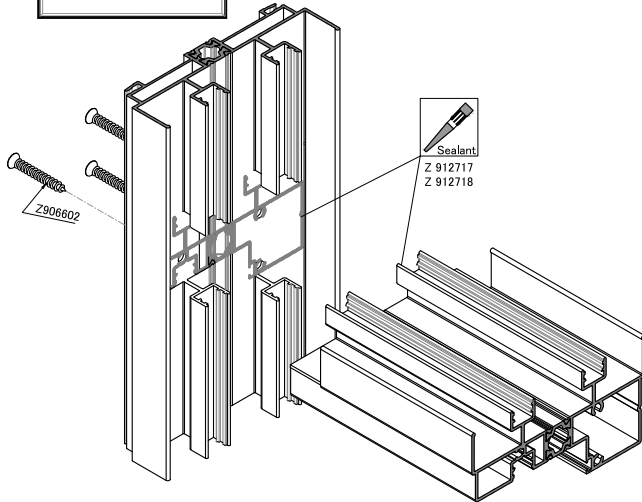
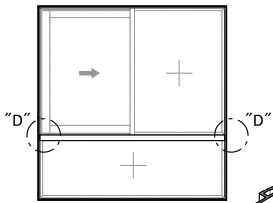

view - A

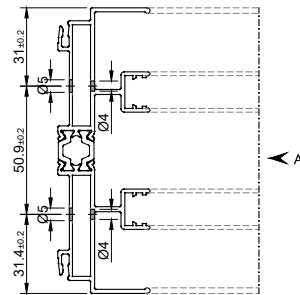

Detail "D"
B061300
Double track frame profile

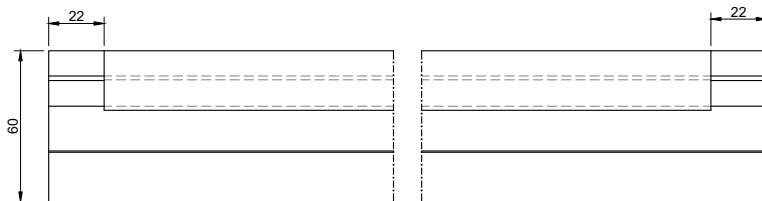

view - B

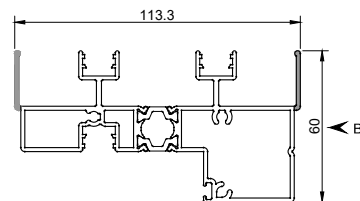

B061302
Transom profile

Processing steps

1. Starting at the top center, put on the gasket continuously to the glass.
Rip the corners for this at the pre-cuts
2. Glue seal joint in the top center

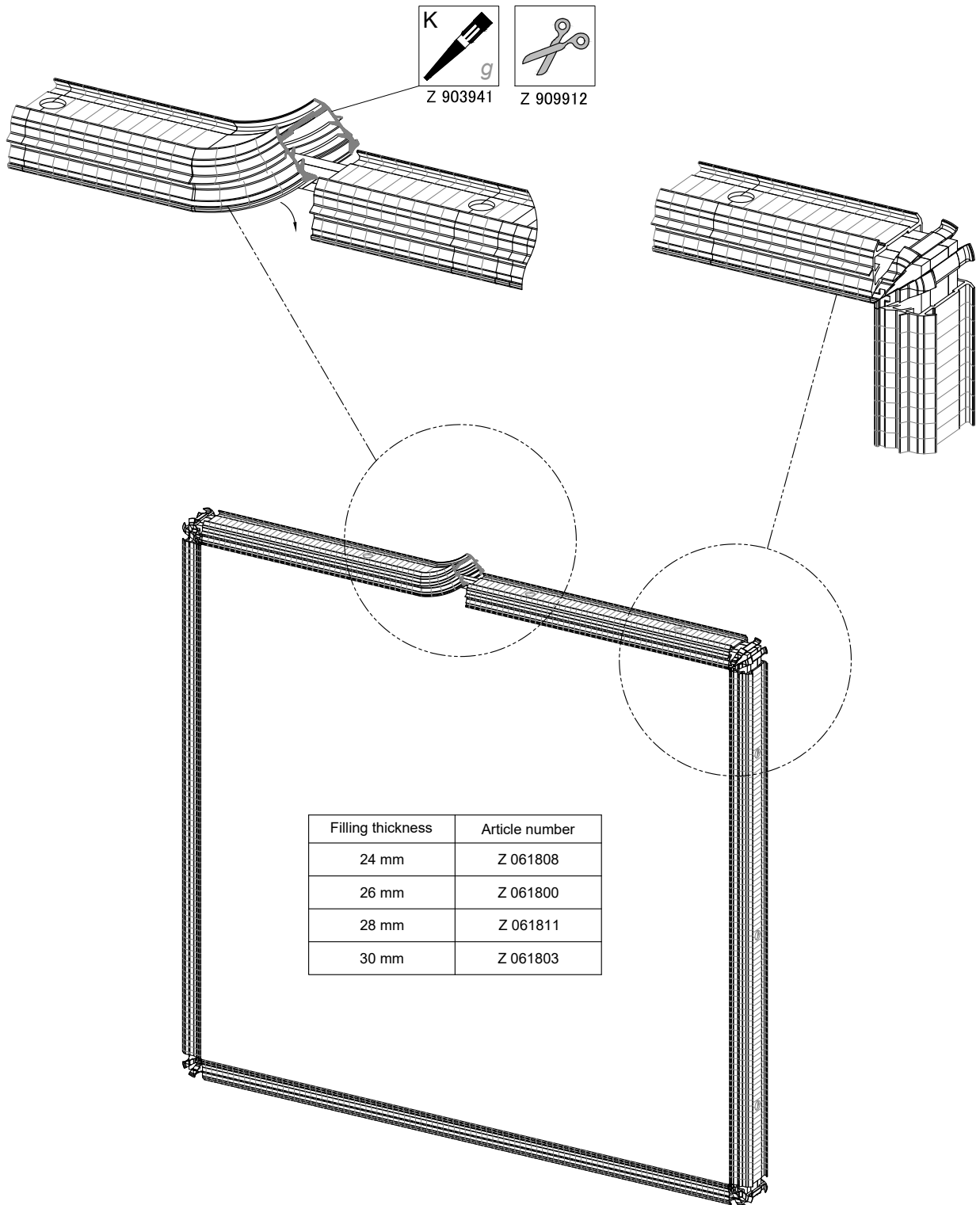

- Processing steps
1. Plug profiles
 2. Screw together

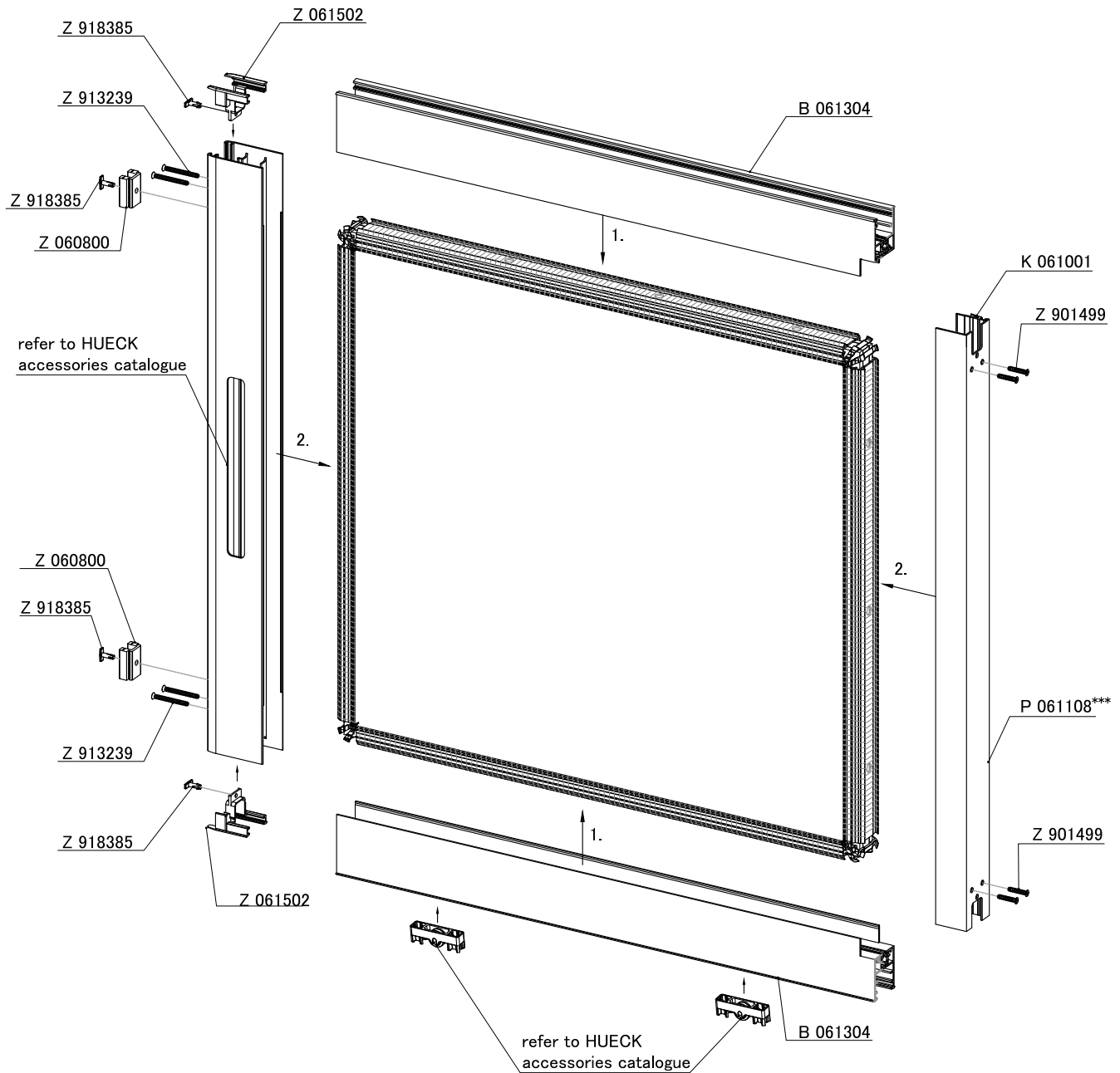

*** optional item
 * for high performance use bulk gasket (Z 061815) instead of brush

When sash height >2200 to 3000 mm
glass and sash profile has to be gulled (1 x 300mm)

When sash height >3000 to 3400 mm
glass and sash profile has to be gulled (2 x 300mm)

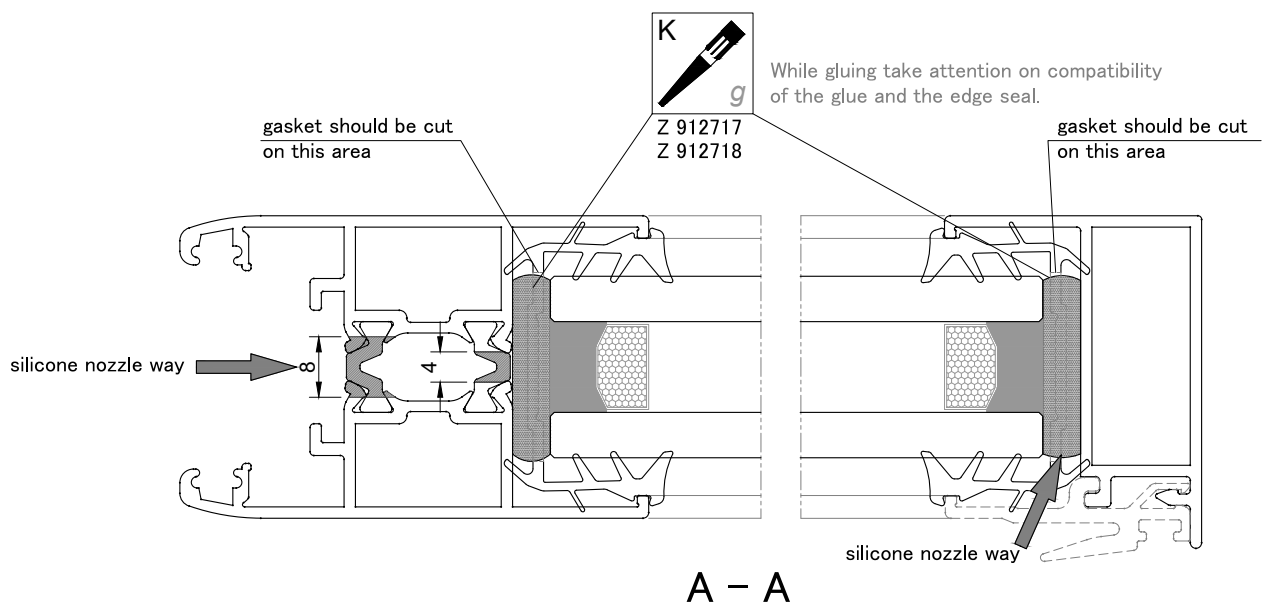
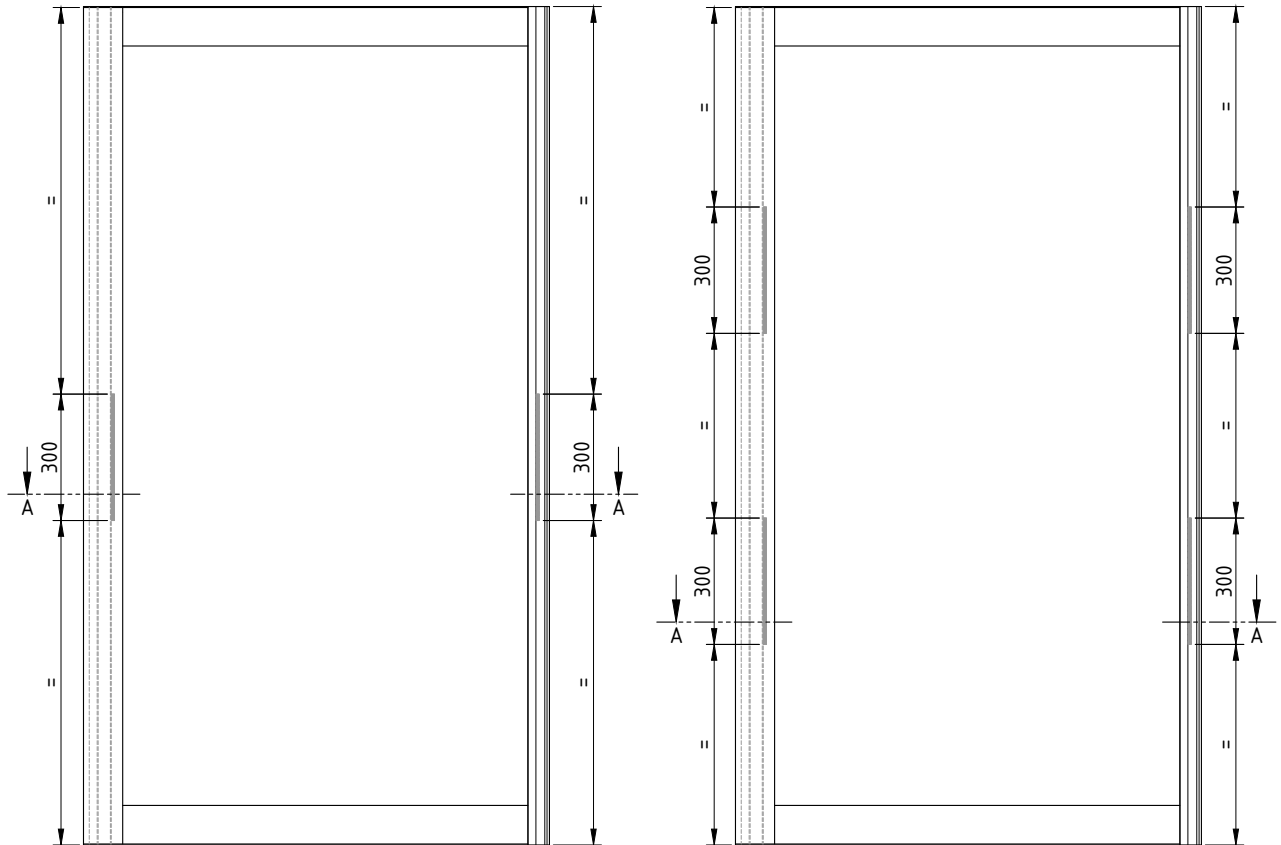

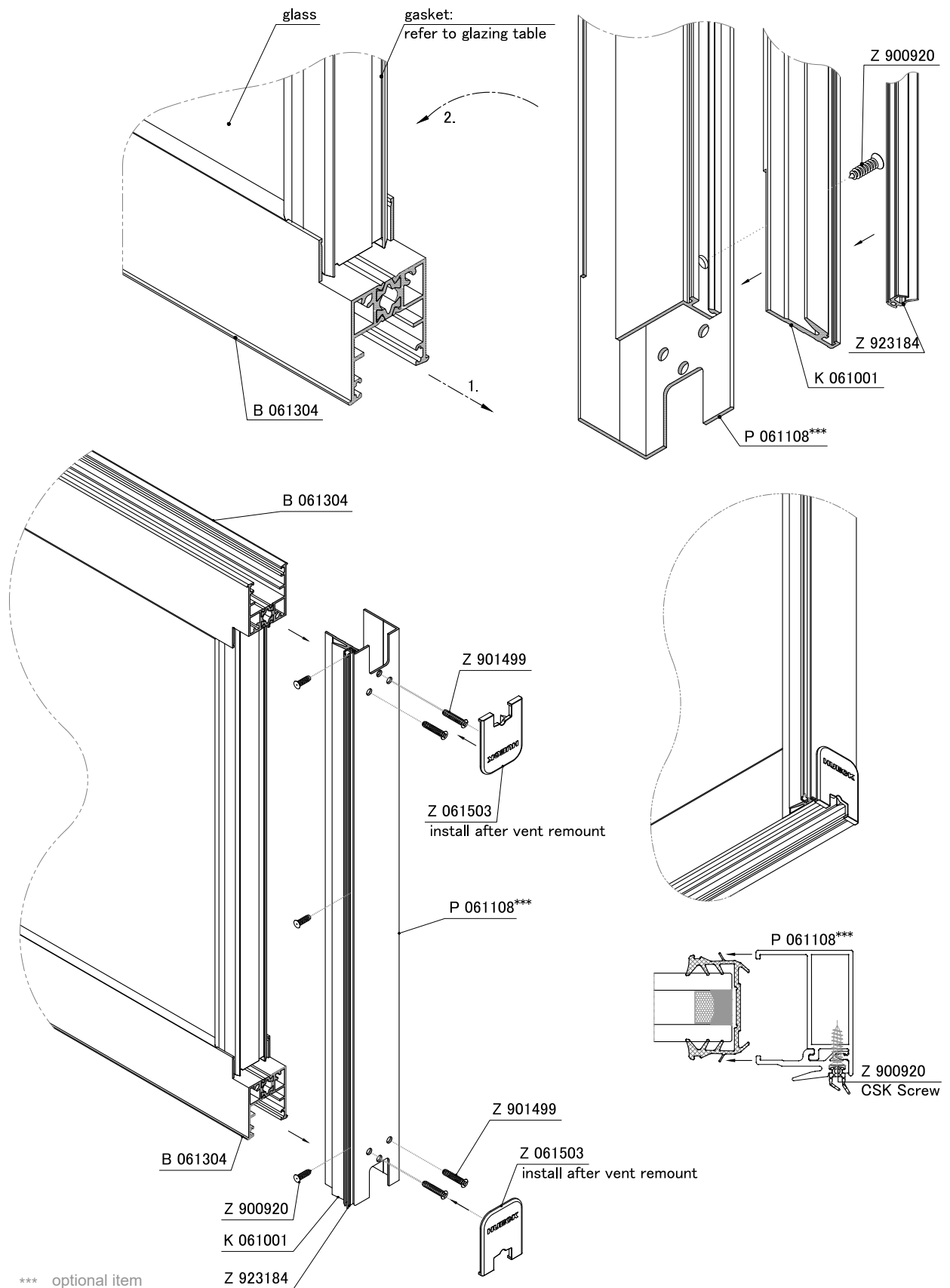

*** optional item

* for high performance use bulk gasket (Z 061815) instead of brush

12/2022

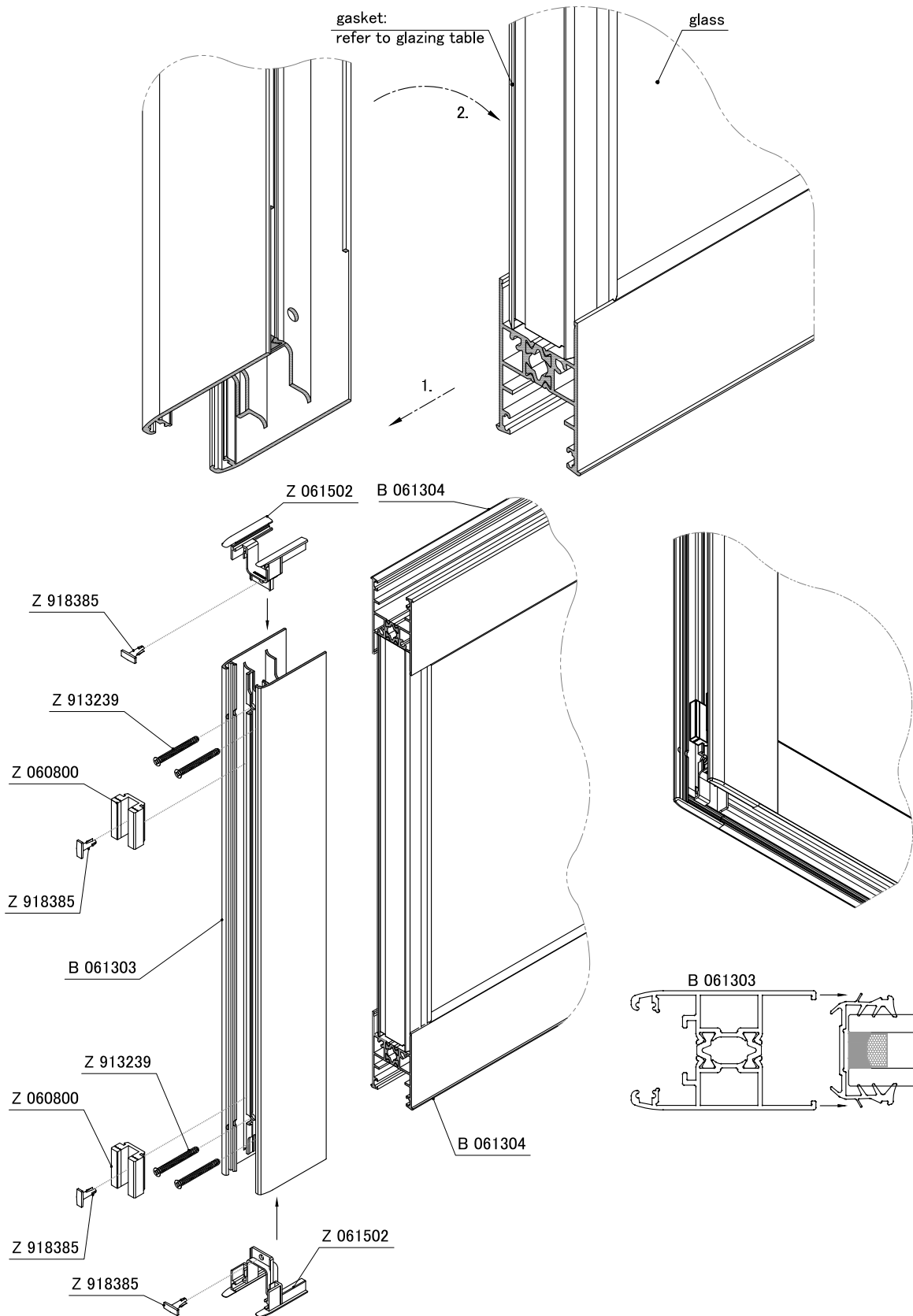

*** optional item

* for high performance use bulk gasket (Z 061815) instead of brush

Processing

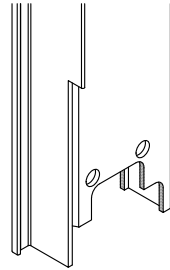
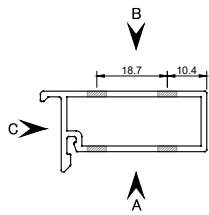

notch at top & bottom

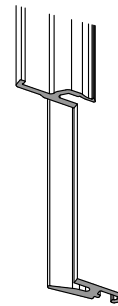

notch at top & bottom

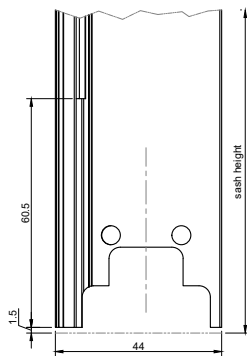
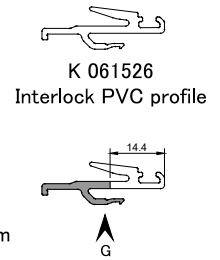

view-A

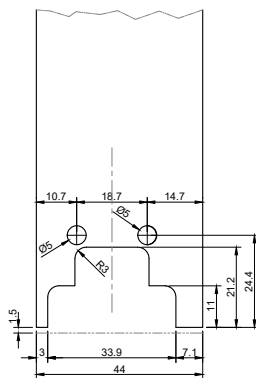

view-B
P061150

secondary sash profile vertical
(labyrinth side)

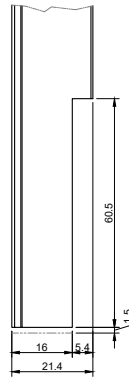

view-C

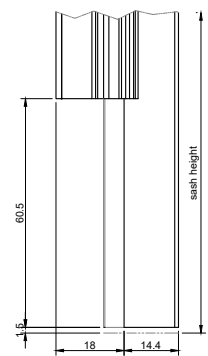

view-G

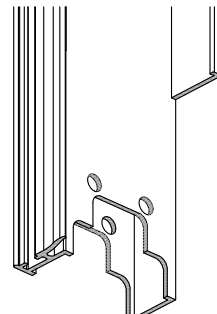
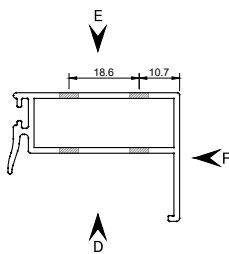

notch at top & bottom

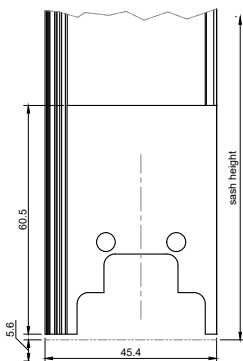

view-D

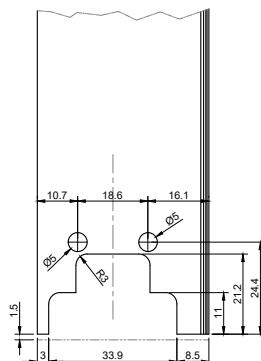

view-E
P061149

secondary sash profile vertical
(labyrinth side)

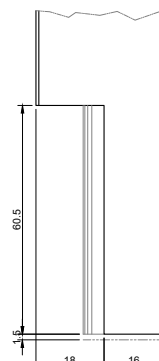

view-F

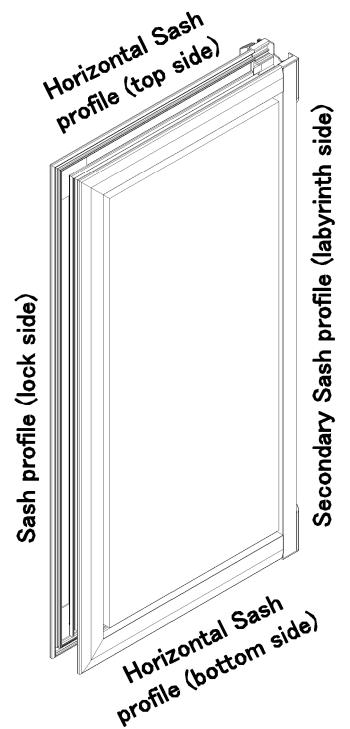

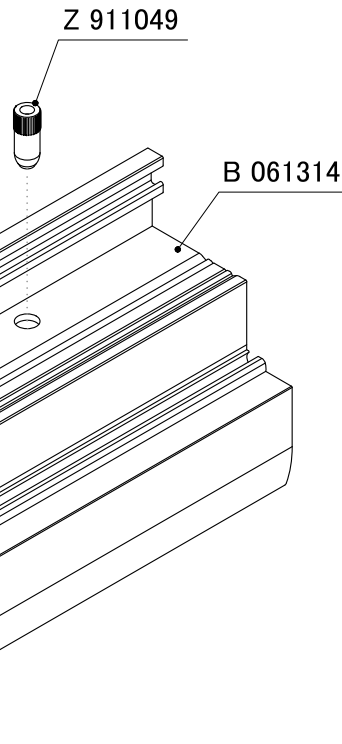
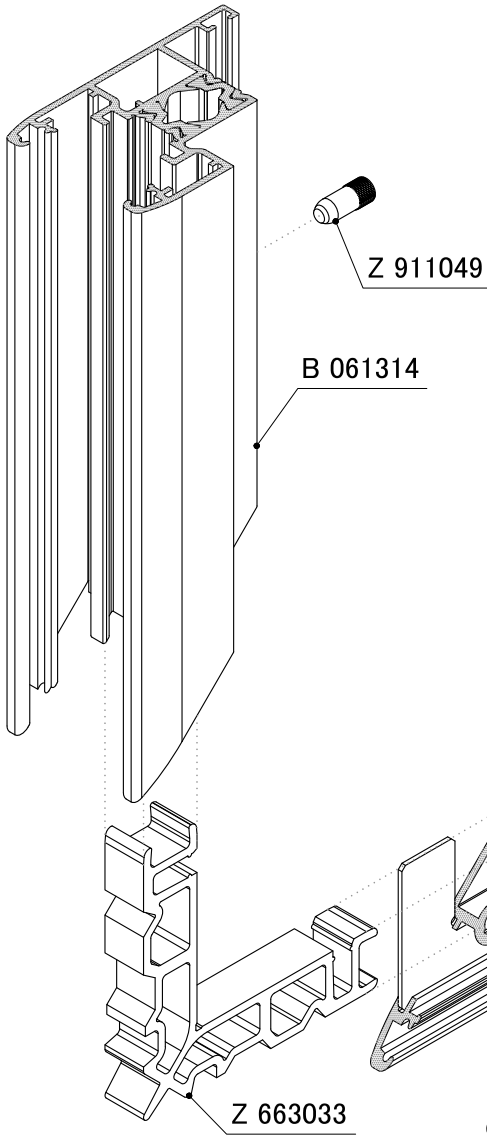
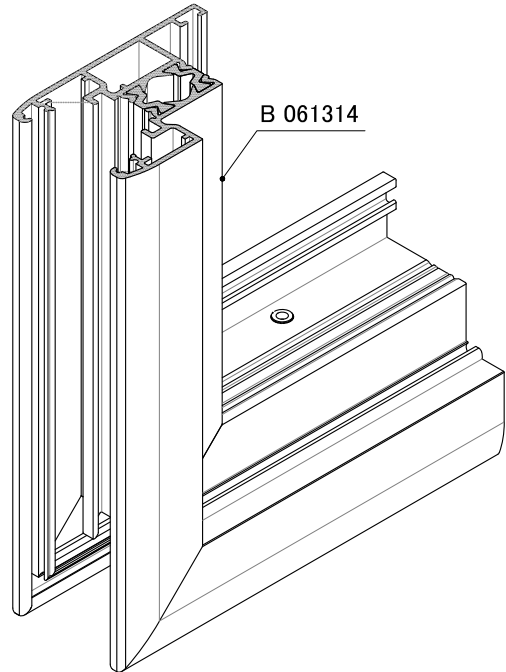
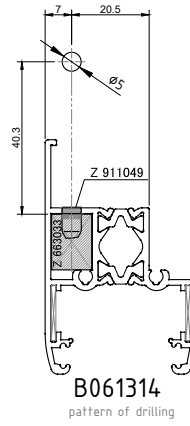
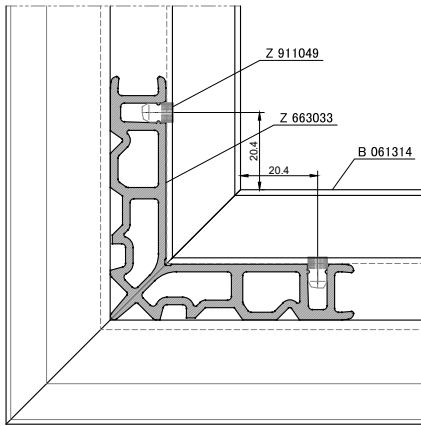

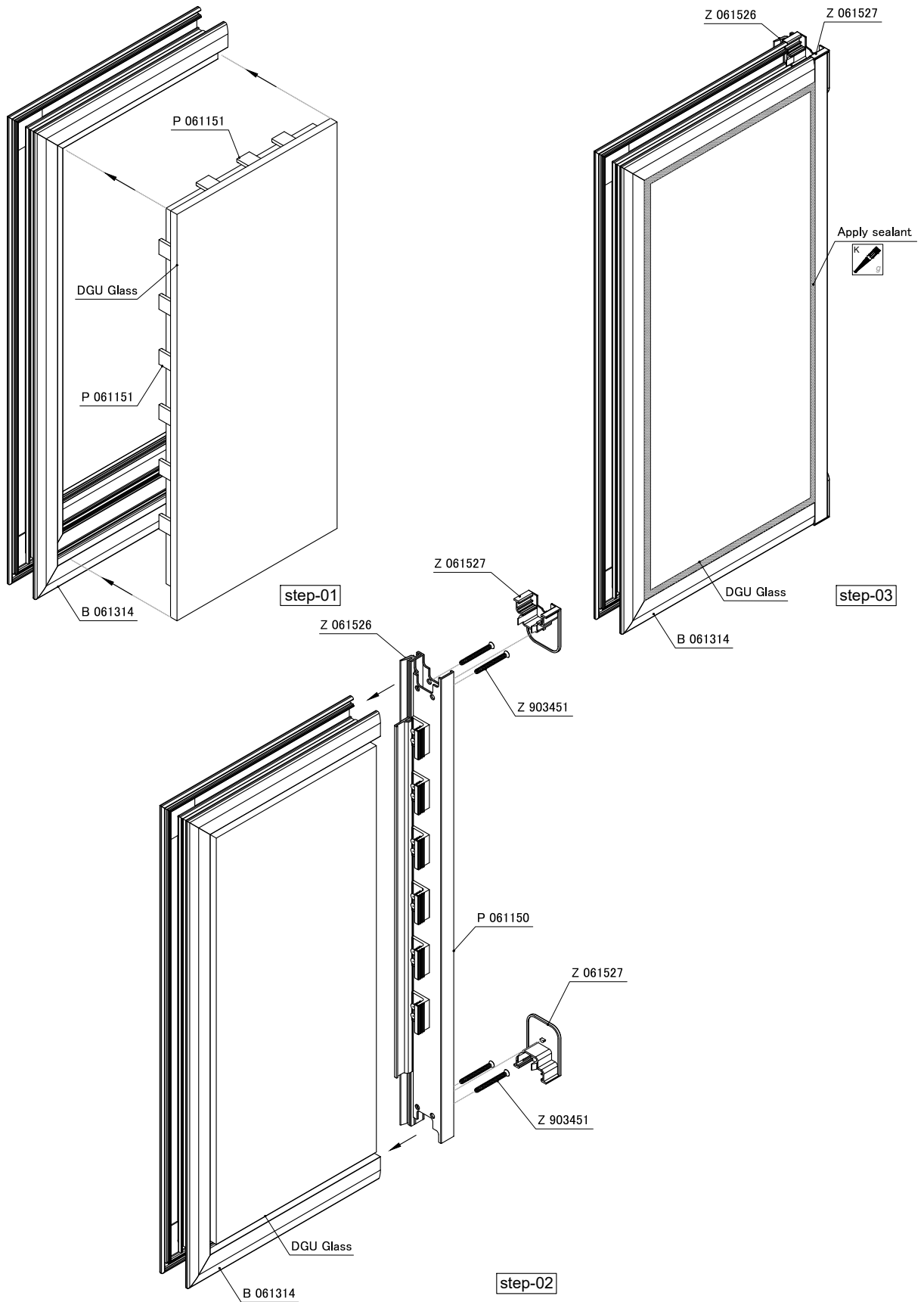

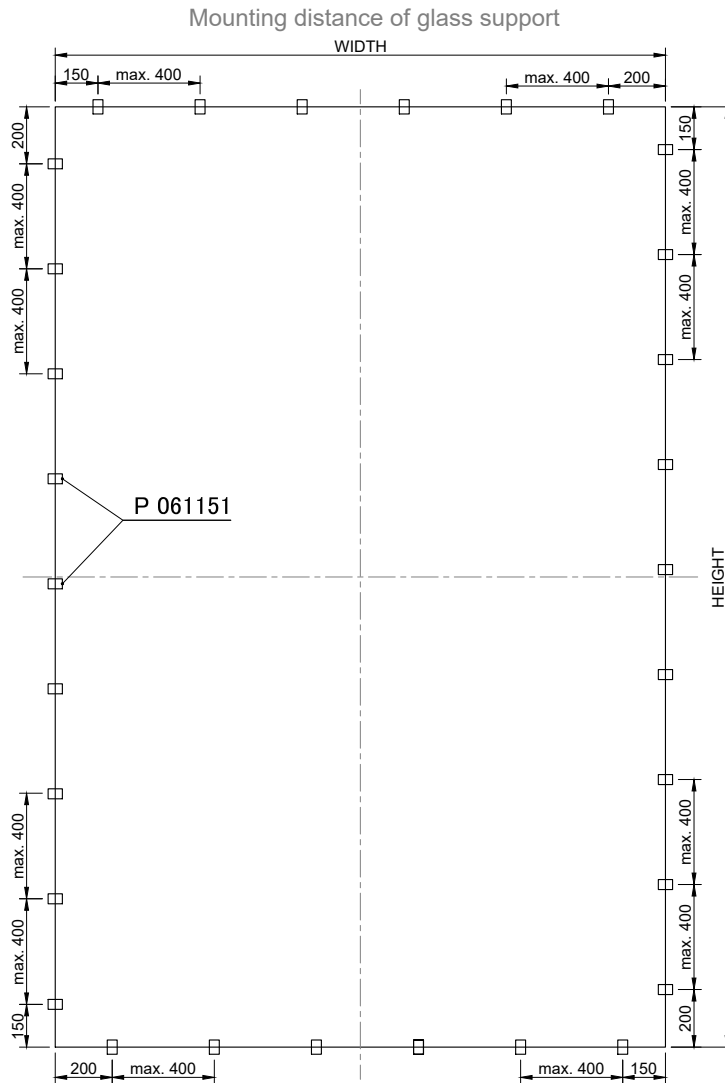

Toggle distance 200 - 400 mm depends on the glass static and the structural conditions

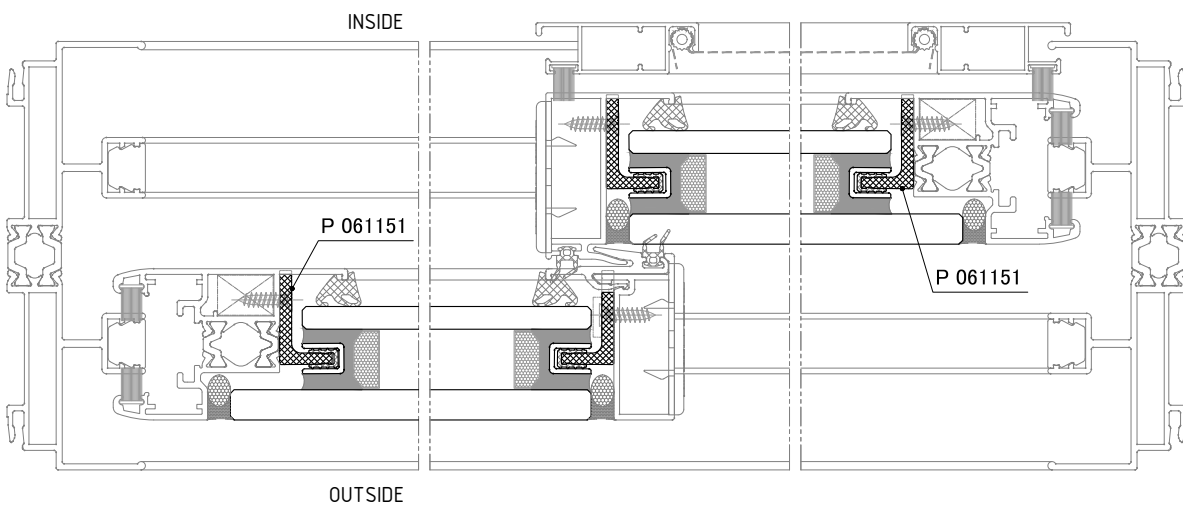

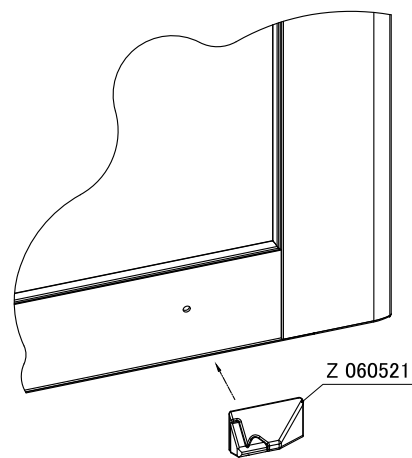
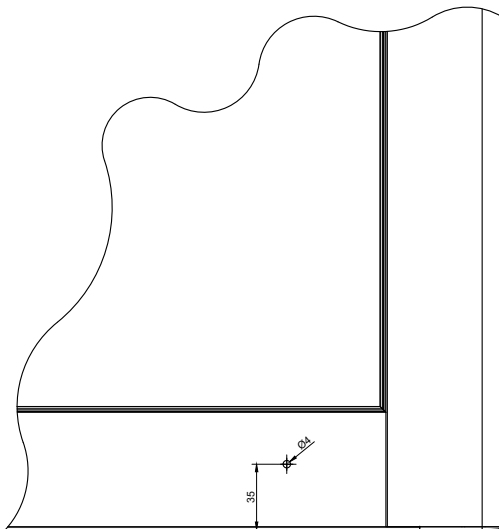
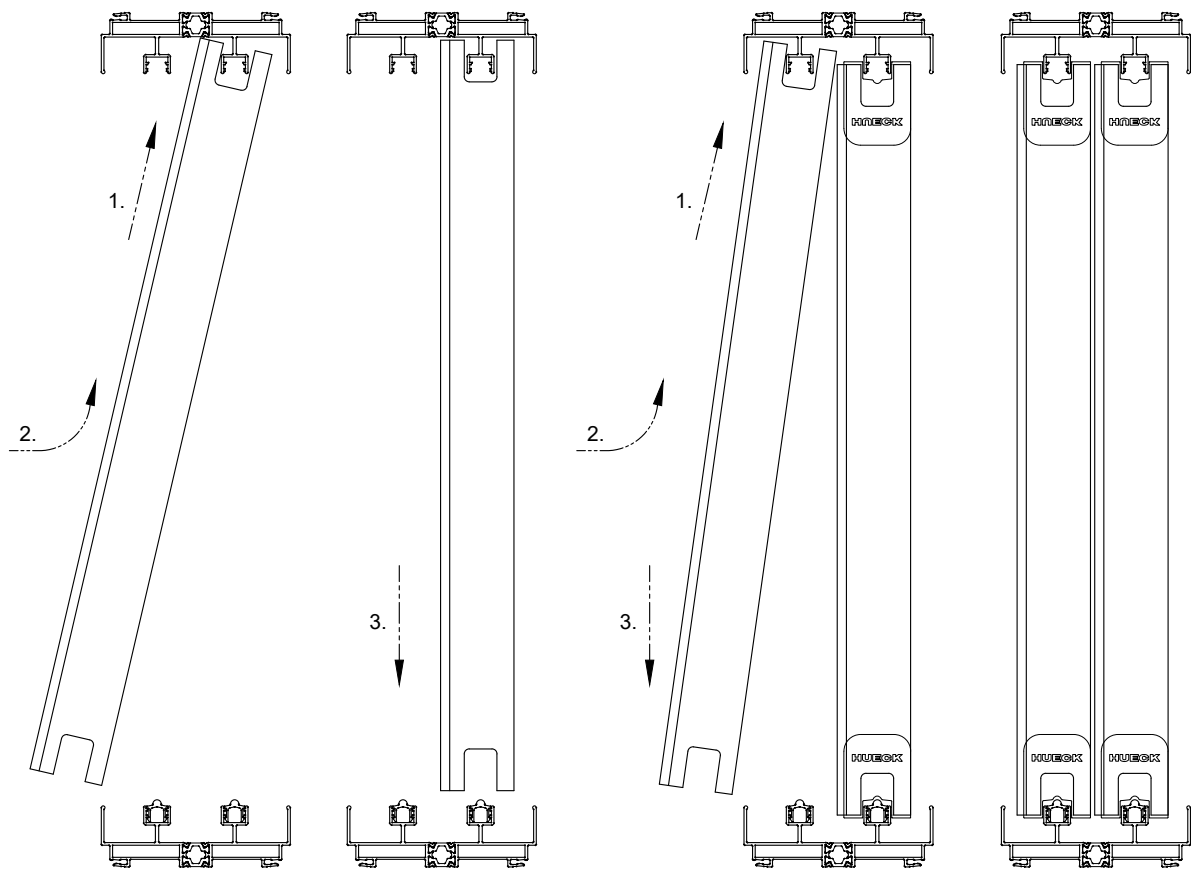

Processing

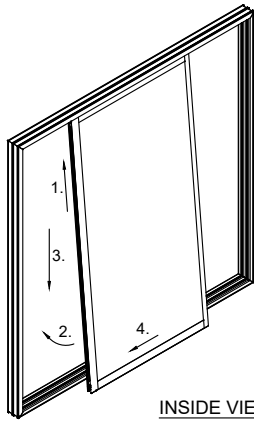

INSIDE VIEW

step-01

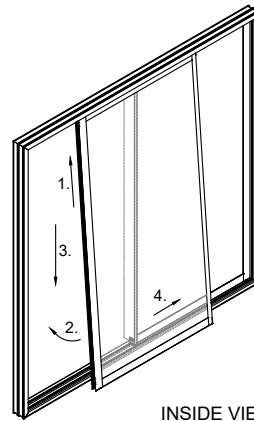

INSIDE VIEW

step-02

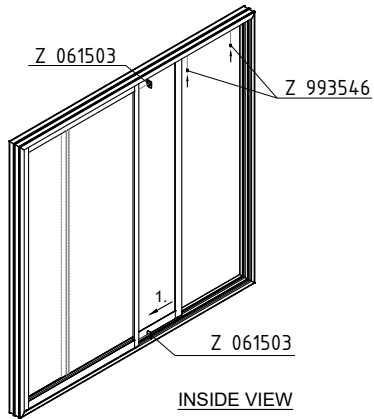

INSIDE VIEW

step-03

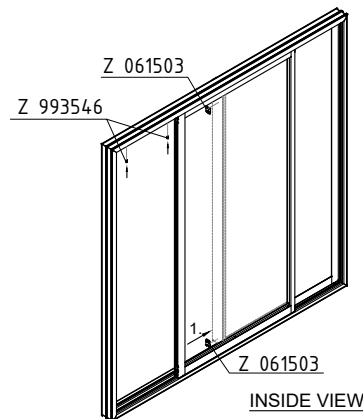

INSIDE VIEW

step-04

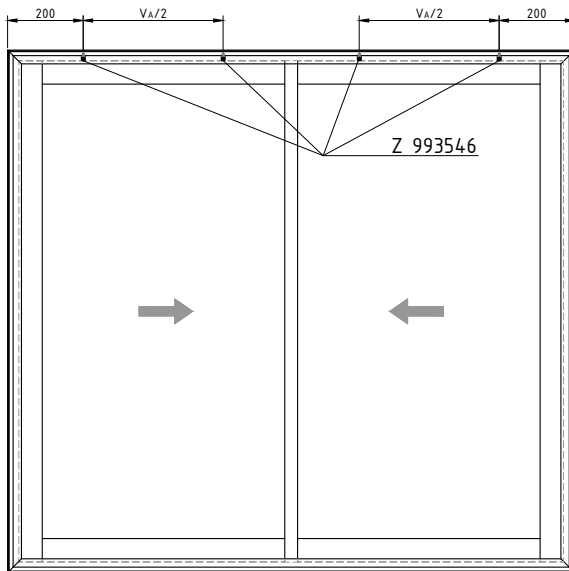

ELEVATION (OUTSIDE)

$V_A/2$ = vent wide

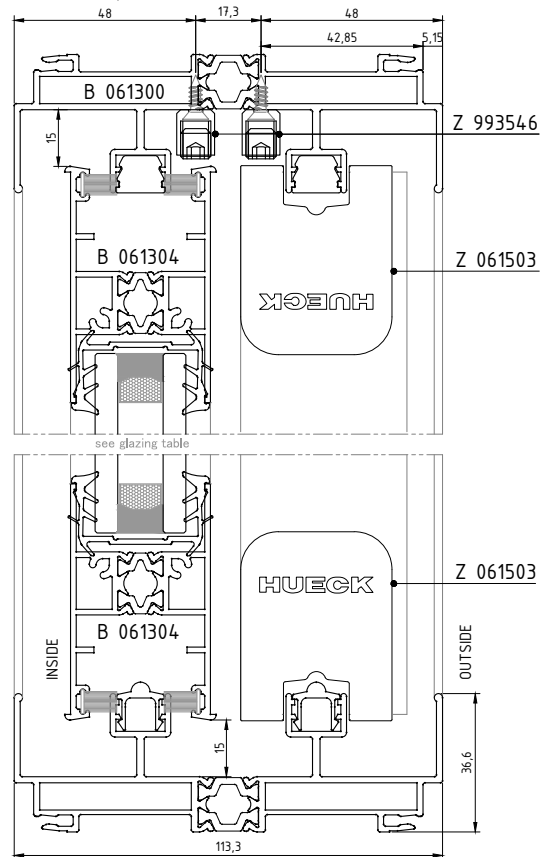

Fix the sash frame

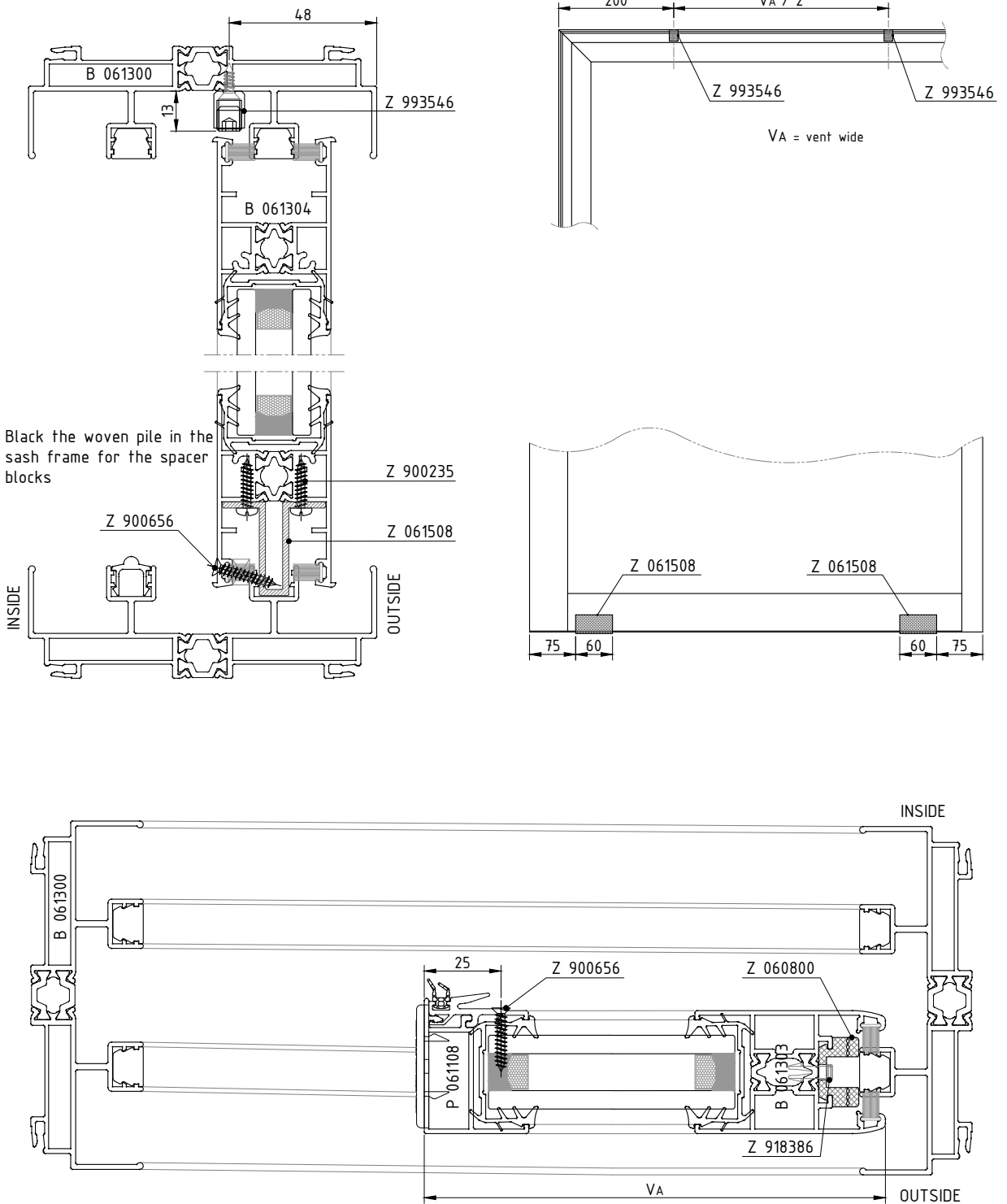

Processing

- 1) Cut the profile as cutting list.
- 2) Place the woven pile (Z 061812) on the profile groove.

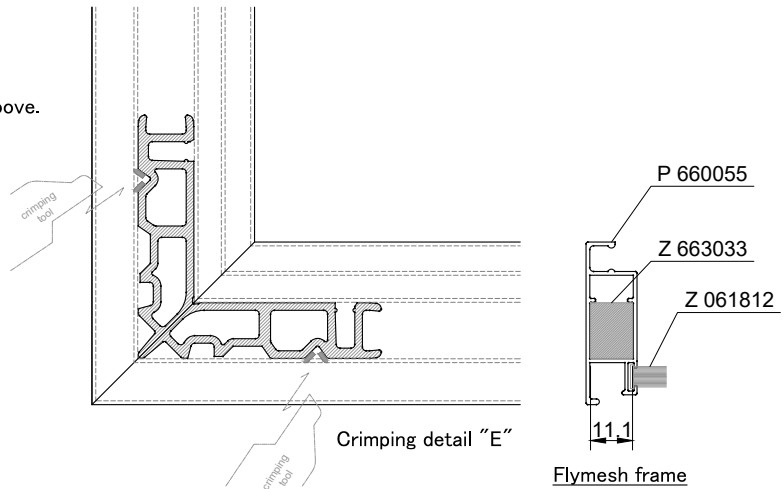
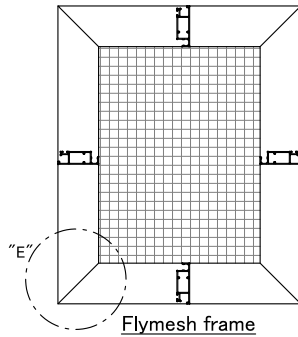

- 3) Insert the corner connector on the profile.

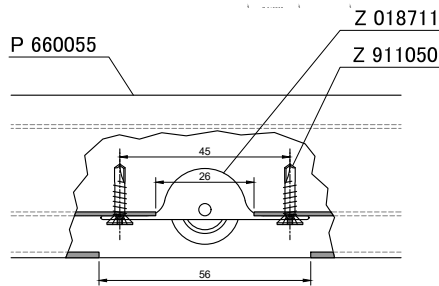

- 4) Place the rollers following the position.

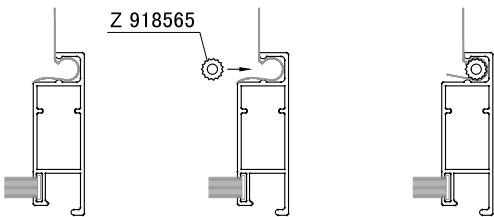

- 5) Place the mosquito net and fix it with PVC gasket. cut away the rest of the net

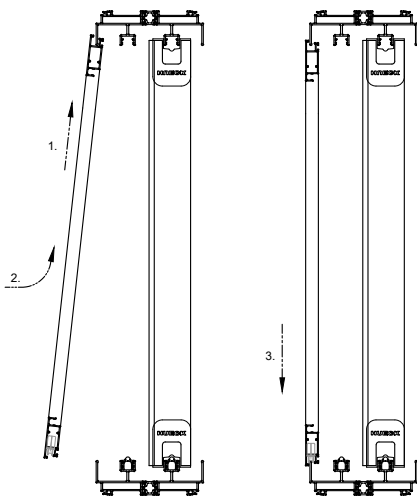
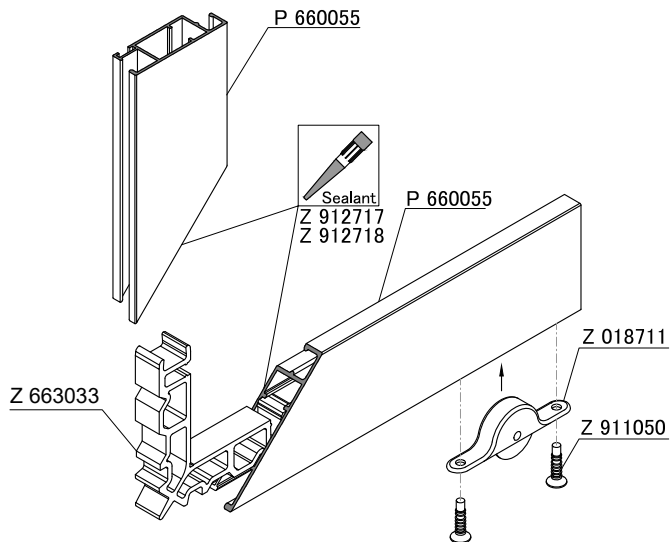

- 6) Install the fly screen in the element.

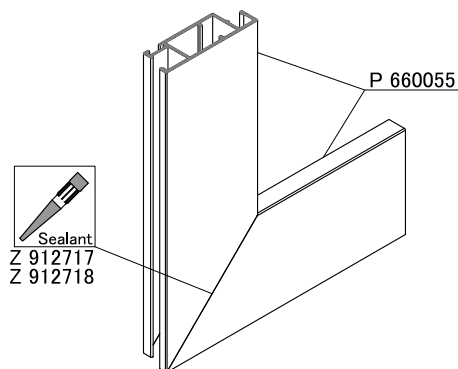

*** optional item

* for high performance use bulk gasket (Z 061815) instead of brush (Z 061812)

ALUMINIUM SYSTEMS @
HUECK
GERMAN ENGINEERING SINCE 1814

HUECK Middle East Aluminum Systems .LLC

P.O Box 119599
DIP 2, Plot no. 597-936
Community 597, Street 56
Dubai , UAE
hueck.ae



HUECK Documentation App
<http://qr.hueck.com/docuapp>



HUECK YouTube-Channel
www.youtube.de/hueckaluminium



HUECK Facebook
<http://qr.hueck.com/facebook>



HUECK 3D App
<http://qr.hueck.com/3dapp>

Firmenstempel Company stamp

Aktuelle Informationen und umfangreiche Downloads finden Sie unter
Current information and a comprehensive download section can be found at WWW.HUECK.AE

Es gelten unsere allgemeinen „Verkaufs- und Lieferbedingungen“, die wir Ihnen auf Nachfrage gern zusenden oder die Sie auf unserer Internetseite finden.
Our "General Terms and Conditions of Sale" apply which we will send you on request or which you find on the Internet at our domain.